

APPROVED: *Ayman Alqudwah*
Professional Engineer

DATE: 1/21/2016

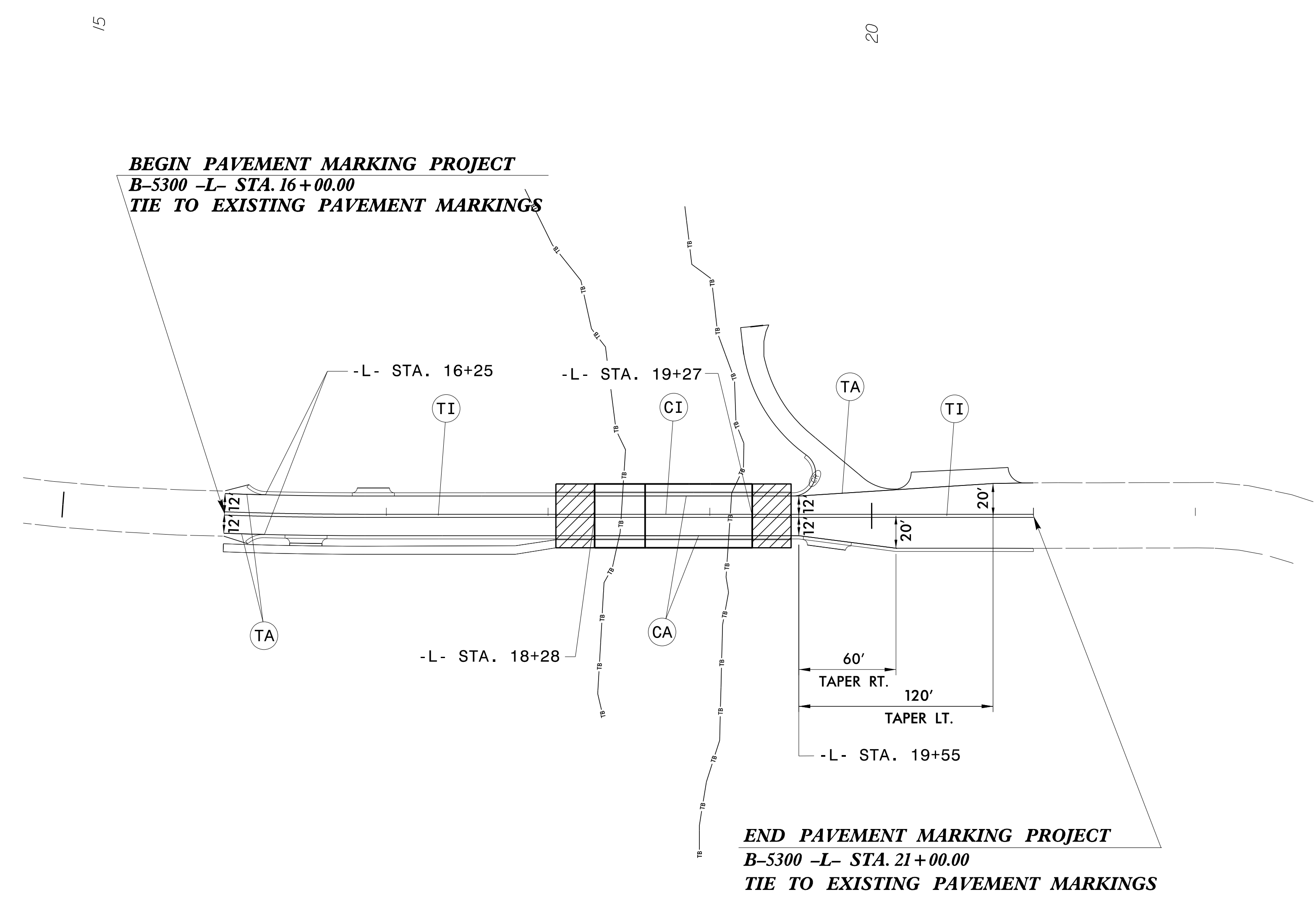

**DOCUMENT NOT CONSIDERED FINAL
 UNLESS ALL SIGNATURES COMPLETED**



PAVEMENT MARKING SCHEDULE

SYMBOL	DESCRIPTION
THERMOPLASTIC (4", 90 MILS)	
TA	WHITE EDGELINE
THERMOPLASTIC (4", 120 MILS)	
TI	YELLOW DOUBLE CENTER
COLD APPLIED PLASTIC (4")	
CA	WHITE EDGELINE
CI	YELLOW DOUBLE CENTER
PERMANENT RAISED PAVEMENT MARKERS	
MA	YELLOW & YELLOW

PAVEMENT MARKING DETAIL

1/21/2016
 P:\Projects-B\B5300\Traffic\Signing\CADD\PM\B5300_pmp_psh_s02.dgn
 User:rtward