

BAGGED STONE AND PIPE SHALL BE PLACED IMMEDIATELY AFTER COMPLETION OF END BENT EXCAVATION. PIPE MAY BE EITHER CONCRETE, CORRUGATED STEEL, CORRUGATED ALUMINUM ALLOY, OR CORRUGATED PLASTIC. PERFORATED PIPE WILL NOT BE ALLOWED.

BAGGED STONE SHALL REMAIN IN PLACE UNTIL THE ENGINEER DIRECTS THAT IT BE REMOVED. THE CONTRACTOR SHALL REMOVE AND DISPOSE OF SILT ACCUMULATIONS AT BAGGED STONE WHEN SO DIRECTED BY THE ENGINEER. BAGS SHALL BE REMOVED AND REPLACED WHENEVER THE ENGINEER DETERMINES THAT THEY HAVE DETERIORATED AND LOST THEIR EFFECTIVENESS.

NO SEPARATE PAYMENT WILL BE MADE FOR THIS WORK AND THE ENTIRE COST OF THIS WORK SHALL BE INCLUDED IN THE UNIT CONTRACT PRICE BID FOR THE SEVERAL PAY ITEMS.

TEMPORARY DRAINAGE AT END BENT

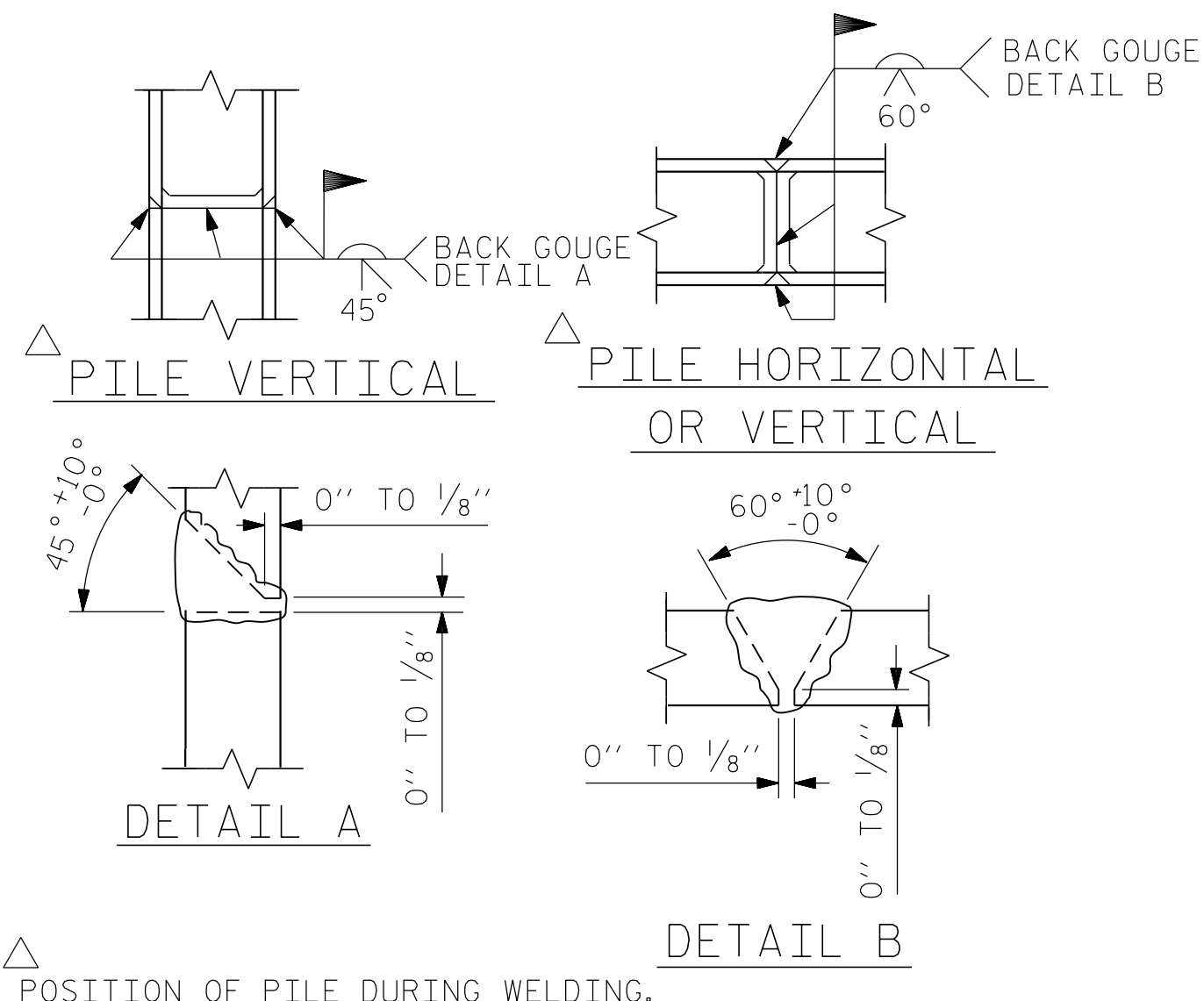

PILE SPLICE DETAILS

BAR TYPES

ALL BAR DIMENSIONS ARE OUT TO OUT.

END BENT No. 1 HP 12 X 53 STEEL PILES NO: 14 LIN. FT.= 350	END BENT No. 2 HP 12 X 53 STEEL PILES NO: 14 LIN. FT.= 385
---	---

BILL OF MATERIAL FOR ONE END BENT					
BAR	NO.	SIZE	TYPE	LENGTH	WEIGHT
B1	16	#10		48'-10"	3376
B2	40	#4	STR	24'-4"	651
B3	24	#4	STR	2'-11"	47
H1	32	#5		12'-6"	418
H2	32	#6	STR	9'-0"	433
S1	76	#4		10'-11"	555
S2	76	#4		3'-8"	187
S3	56	#4		6'-6"	244
V1	136	#4	STR	6'-0"	546
V2	68	#5	STR	9'-5"	669
REINFORCING STEEL (FOR ONE END BENT)					7,126 LBS.
CLASS A CONCRETE BREAKDOWN (FOR ONE END BENT)					
POUR #1 CAP, LOWER PART OF WINGS & COLLARS					57.3 C.Y.
TOTAL CLASS A CONCRETE					57.3 C.Y.

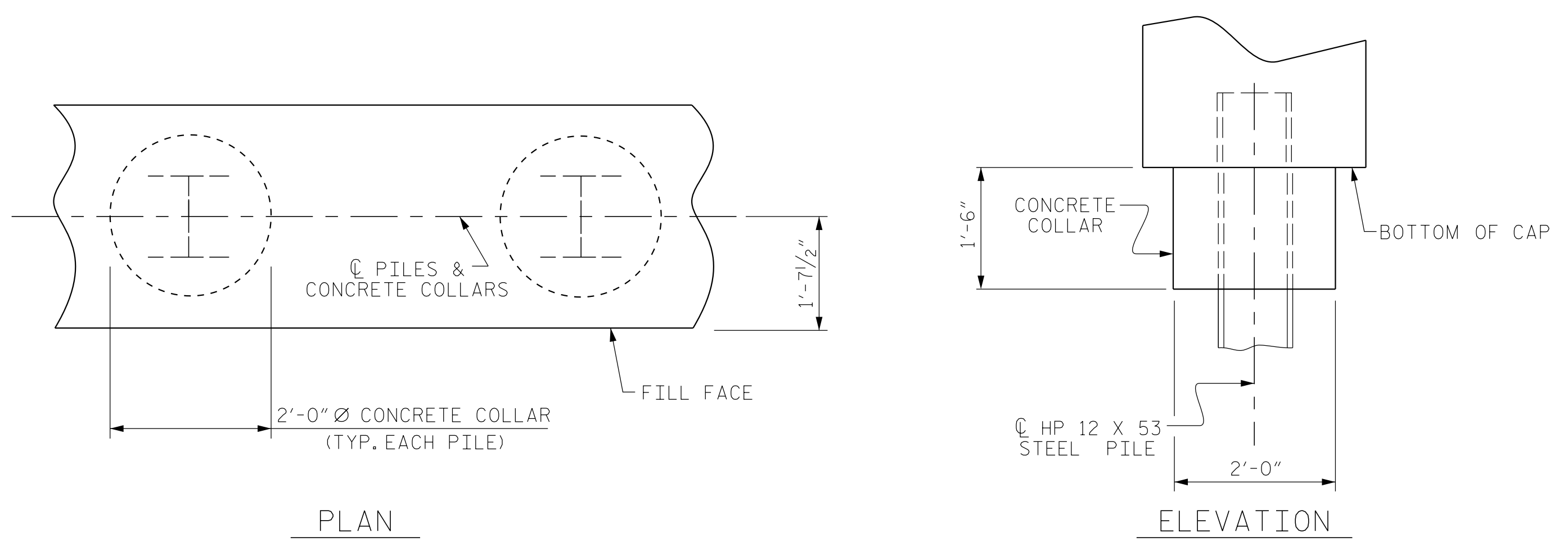

CORROSION PROTECTION FOR STEEL PILES DETAIL
(END BENT No. 1 SHOWN, END BENT No. 2 SIMILAR BY ROTATION)

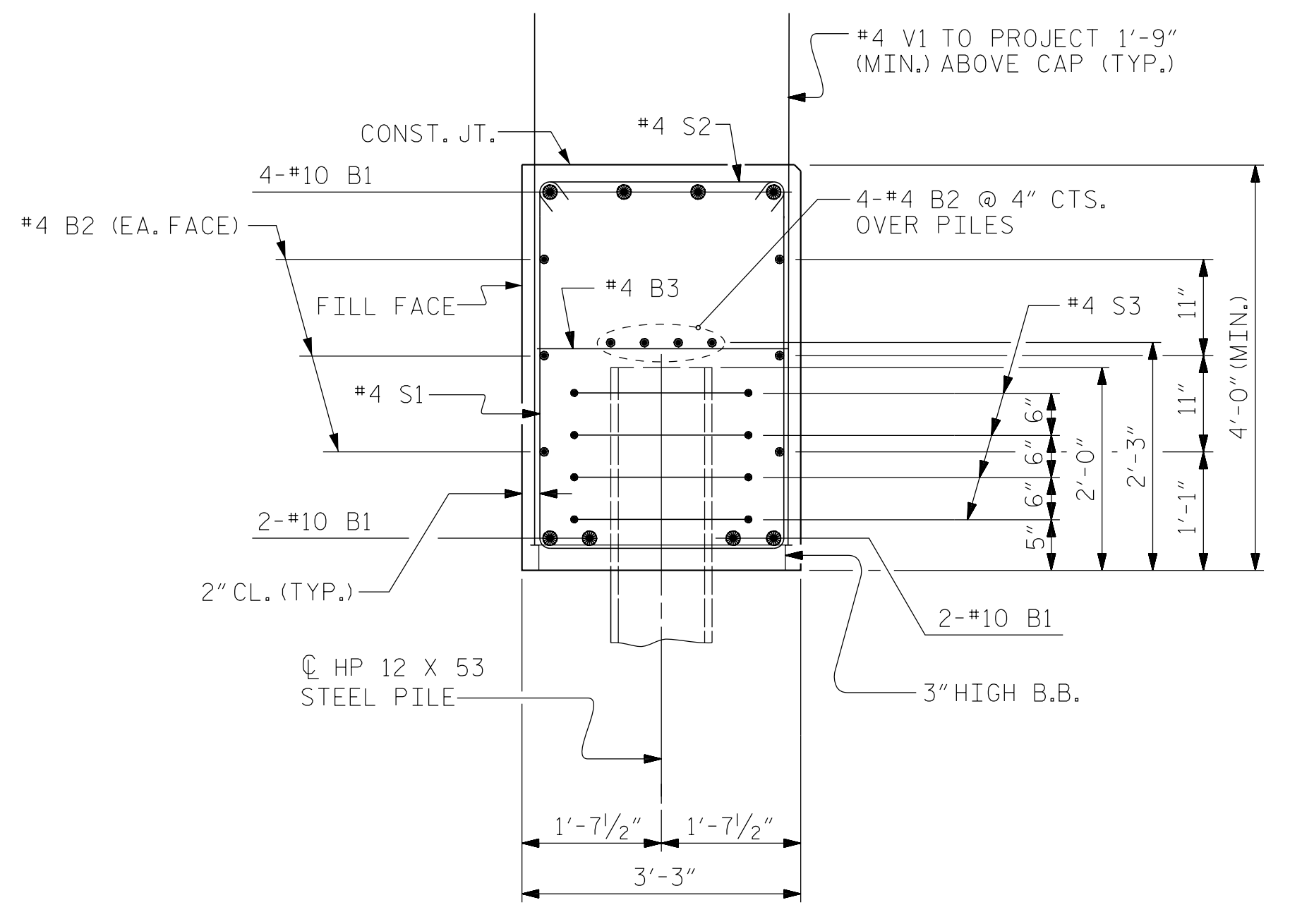

SECTION X-X
(CONCRETE COLLAR NOT SHOWN FOR CLARITY. SEE "CORROSION PROTECTION FOR STEEL PILES DETAIL.")

PROJECT NO. R-5605
TRANSYLVANIA COUNTY
 STATION: 50+83.00 -L-
 SHEET 4 OF 4

STATE OF NORTH CAROLINA
 DEPARTMENT OF TRANSPORTATION
 RALEIGH

SUBSTRUCTURE
 END BENT No. 1 & 2
 DETAILS

REVISIONS						SHEET NO.
NO.	BY:	DATE:	NO.	BY:	DATE:	S-47
1			3			TOTAL SHEETS
2			4			51

ASSEMBLED BY : PFC	DATE : 8/15
CHECKED BY : CMT	DATE : 8/15
DRAWN BY : WJH 12/11	REV. 8/14 MAA/TMG
CHECKED BY : AAC 12/11	

Prepared in the Office of:

DocuSigned by:
 Steven A. Campbell 12/21/2015