

Cable Entrances at Top of Pole

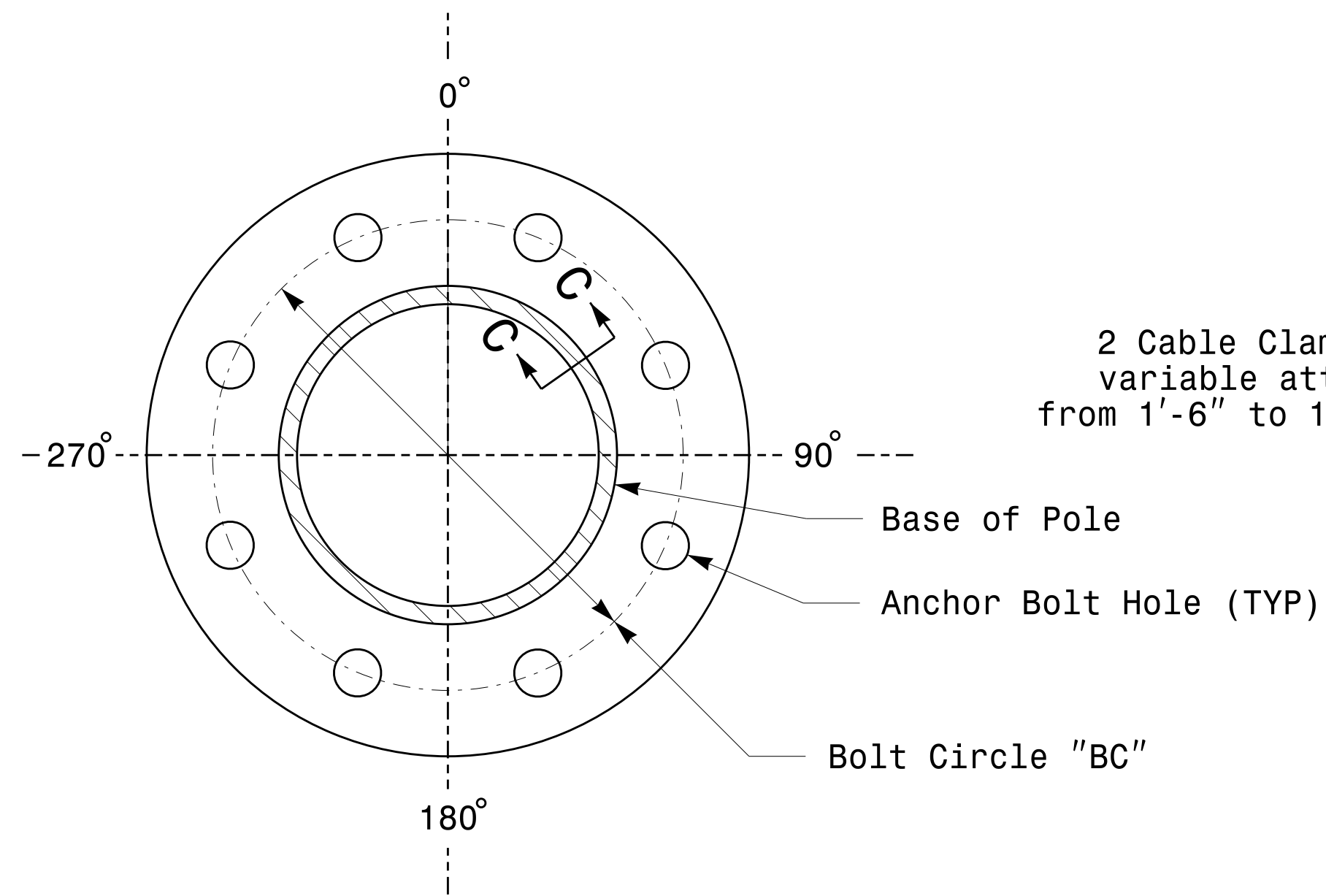

Section B-B  
Pole Base Plate  
(See drawing M2)

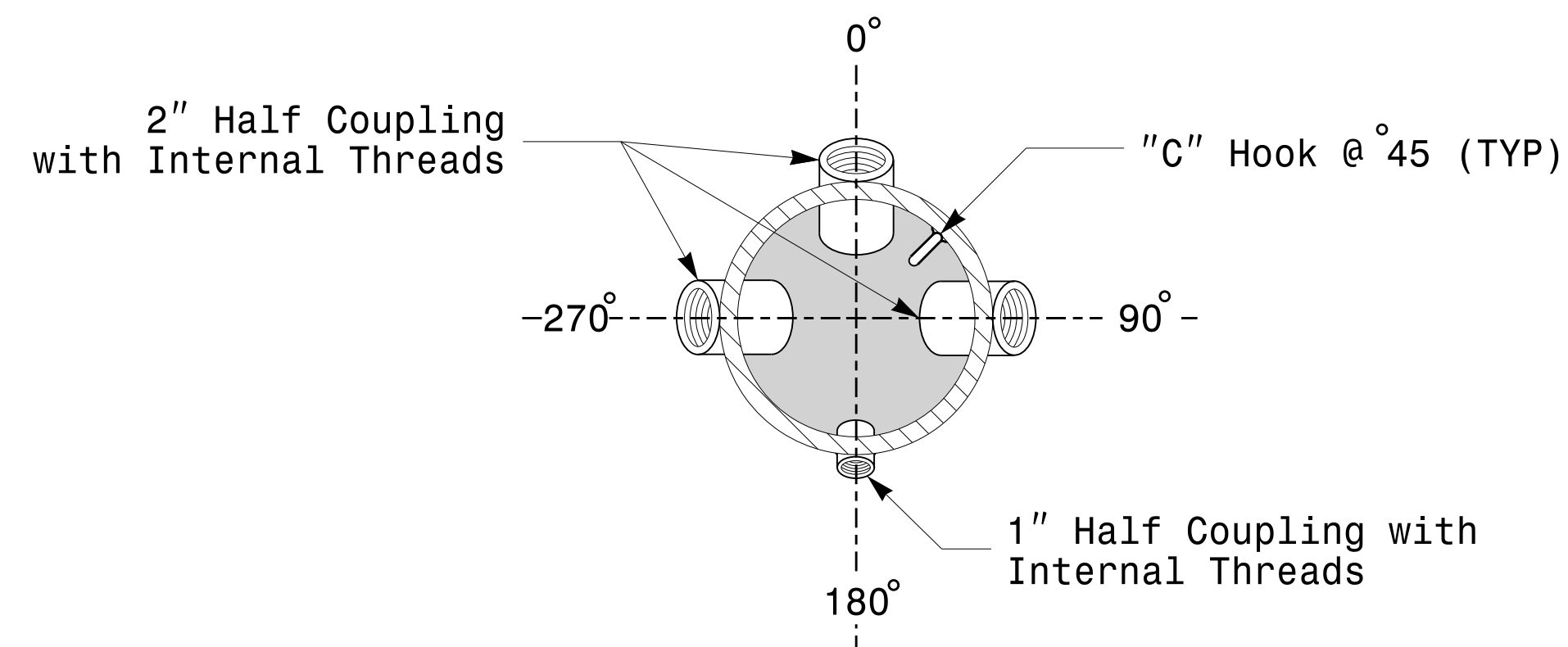

Radial Orientation for Factory Installed  
Accessories at Top of Pole

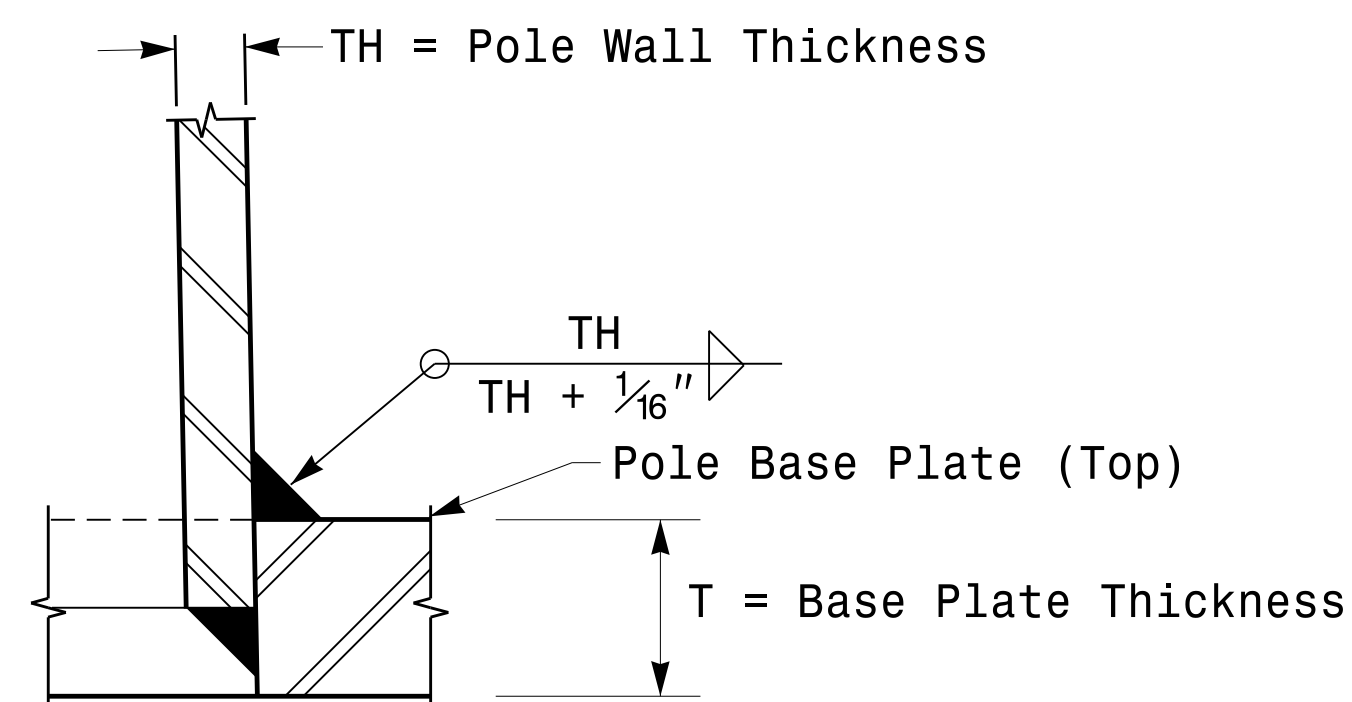

Socket Connection Weld Detail

2 Cable Clamps designed for variable attachment heights from 1'-6" to 10' below the top of the pole.

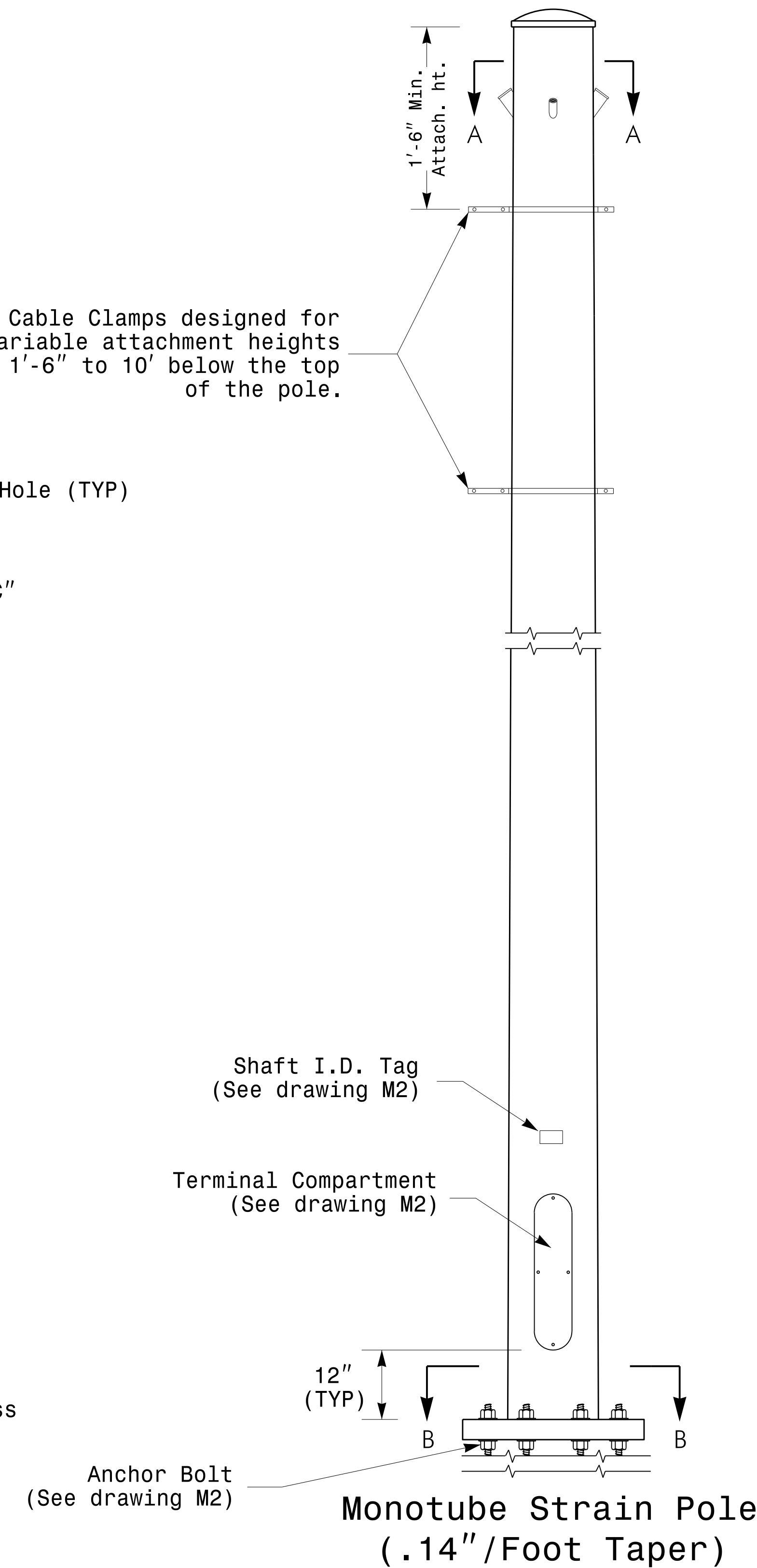

	Typical Fabrication Details For Strain Poles		
	PLAN DATE: AUGUST 2013 PREPARED BY: N. BITTING	DESIGNED BY: C.F. ANDREWS REVIEWED BY: D.C. SARKAR	
SCALE: 0 NA NONE	REVISIONS: _____ INIT.: _____ DATE: _____	SIG. INVENTORY NO.	_____

08-26-2014 08:51  
 S:\TCS\Signal Design Section\Eastern Region\MM Sheets\2012\_M3\_Fab\_Details\_Strain\_Poles.dgn  
 Top of Pole

**Fabrication Details – Strain Poles**