

STATE	PROJECT NO.	SHEET NO.	TOTAL SHEETS
N.C.	2016CPT.10.17.10041.2 - ETC. 2016CPT.10.22.20041.7 - ETC. 2016CPT.10.35.20042.4 - ETC.	23	
F.A. PROJECT NO.			

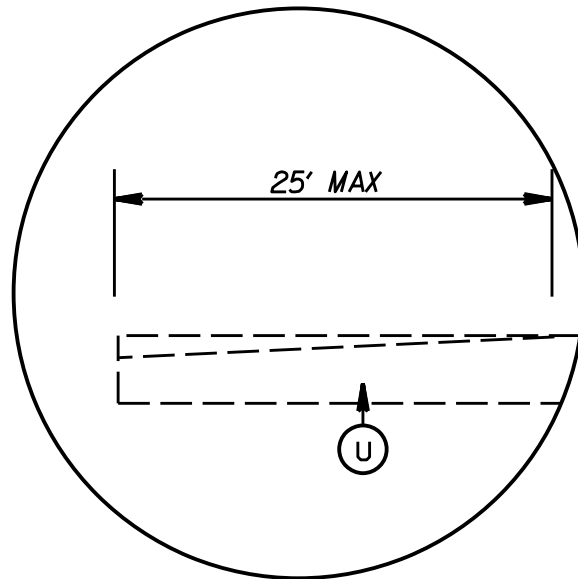

DETAIL FOR INCIDENTAL MILLING (0" TO 2.0")

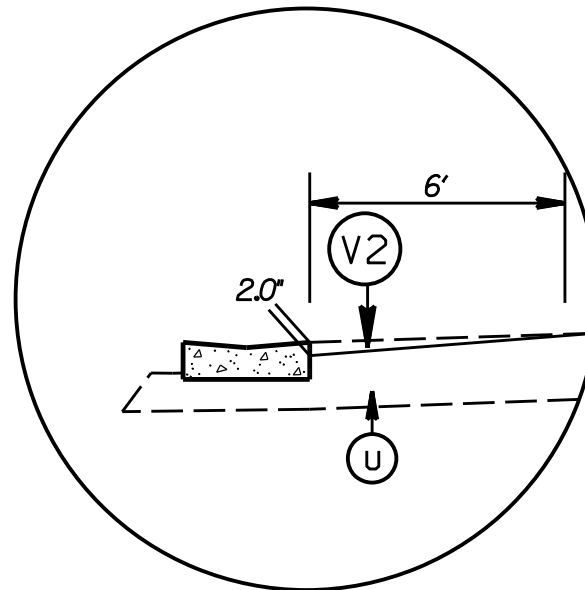

DETAIL FOR PROFILE MILLING (0" TO 2.0")

PAVEMENT SCHEDULE

(C1)	PROP. APPROX. 2.0" ASPHALT CONC. SURFACE COURSE, TYPE S9.5C, AT AN AVERAGE RATE OF 224 LBS. PER SQ. YD.
(C2)	PROP. APPROX. 1.5" ASPHALT CONC. SURFACE COURSE, TYPE S9.5B, AT AN AVERAGE RATE OF 168 LBS. PER SQ. YD.
(C3)	PROP. APPROX. 1.0" ASPHALT CONC. SURFACE COURSE, TYPE SF9.5A, AT AN AVERAGE RATE OF 110 LBS. PER SQ. YD.
(C4)	PROP. APPROX. 2.0" ASPHALT CONC. SURFACE COURSE, TYPE S9.5B, AT AN AVERAGE RATE OF 224 LBS. PER SQ. YD.
(C5)	PROP. ASPHALT SURFACE TREATMENT, TYPE AST DOUBLE SEAL (*78M), TO BE PLACED AT THE END OF EACH DAY'S PRODUCTION.
(D1)	PROP. APPROX. 3.0" ASPHALT CONC. INTERMEDIATE COURSE, TYPE I19.0B, AT AN AVERAGE RATE OF 342 LBS. PER SQ. YD.
(D2)	PROPOSED 2.5" ASPHALT CONC. INTERMEDIATE CORSE, TYPE I19.0B, AT AN AVERAGE RATE OF 285 LBS. PER SQ. YD.
(D3)	AST MAT COAT = 6M
(E1)	PROPOSED 8" OF ASPHALT CONC. BASE COURSE, B25.0C, AT AN AVERAGE RATE 456 LBS. PER SQ. YD., IN EACH OF TWO LAYERS.
(E2)	PROPOSED 6" OF ASPHALT CONC. BASE COURSE, B25.0B, AT AN AVERAGE RATE 342 LBS. PER SQ. YD., IN EACH OF TWO LAYEERS.
(U)	EXISTING PAVEMENT
(T1)	SHOULDER RECONSTRUCTION
(T2)	SHOULDER CONSTRUCTION
(V1)	MILLING OF EXISTING PAVEMENT, 2.0" IN DEPTH.
(V2)	MILLING OF EXISTING PAVEMENT, 1.5" IN DEPTH
(V3)	PROFILE MILLING EXISTING ASPHALT, 0 - 2"
(Z)	FULL DEPTH RECLAMATION

PATCHING DETAIL

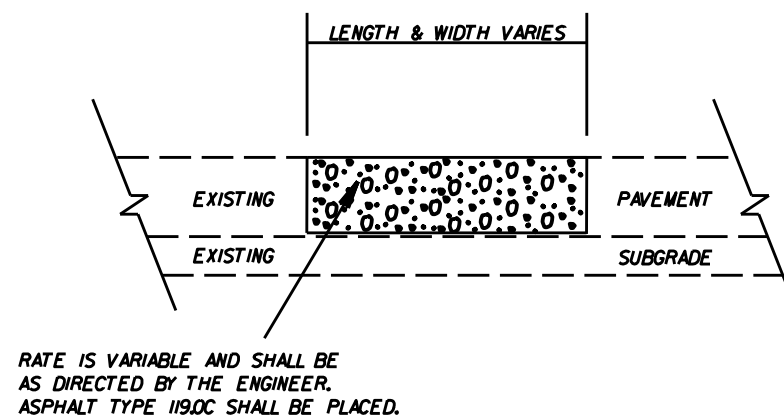

2016-2017
ANSON COUNTY RESURFACING

SCALE	-NA-	REVISIONS
DATE	11/15	
DWG. BY	AMO	
DESIGN BY	AMO	
APPROVED	CLA	

