

**NOTES**

STIRRUPS IN CAP MAY BE SHIFTED AS NECESSARY TO CLEAR DOWELS.

THE CONCRETE IN THE SHADED AREA OF THE WING SHALL BE POURED AFTER THE VERTICAL CONCRETE BARRIER RAIL IS CAST IF SLIP FORMING IS USED.

FOR PILE SPLICE DETAILS, SEE SHEET 4 OF 4.

FOR WING DETAILS, SEE SHEET 3 OF 4.

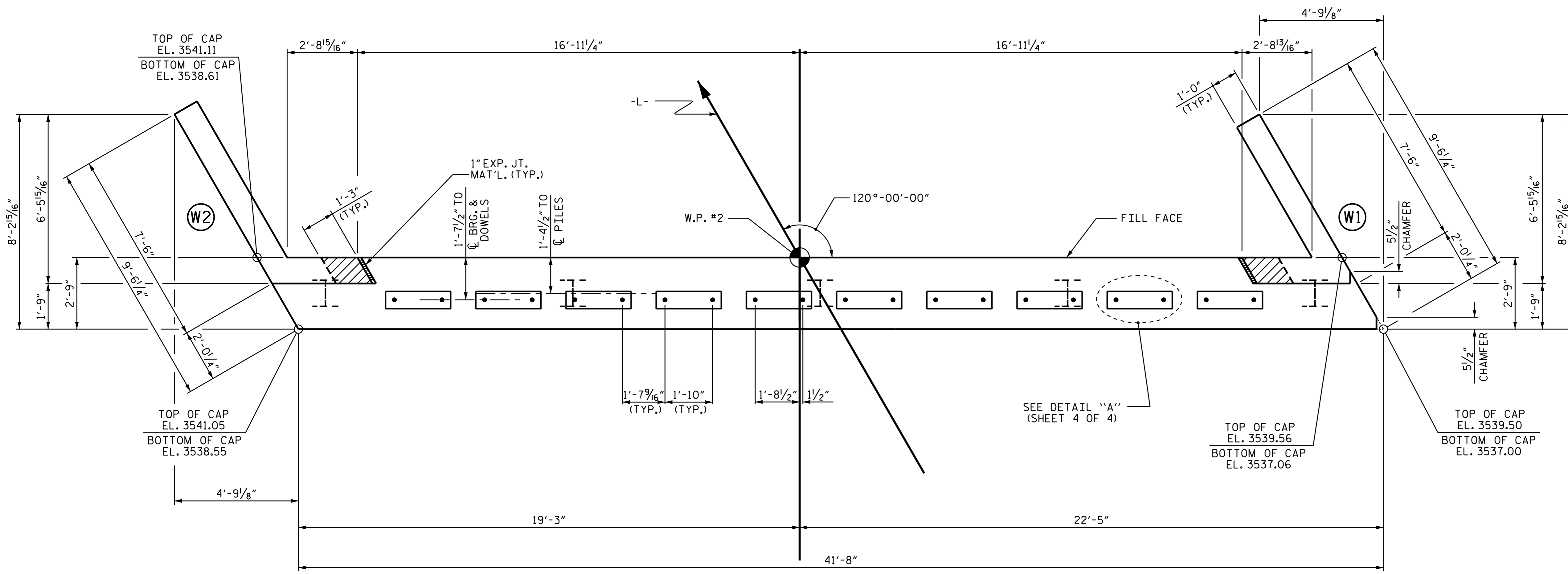

**PLAN**

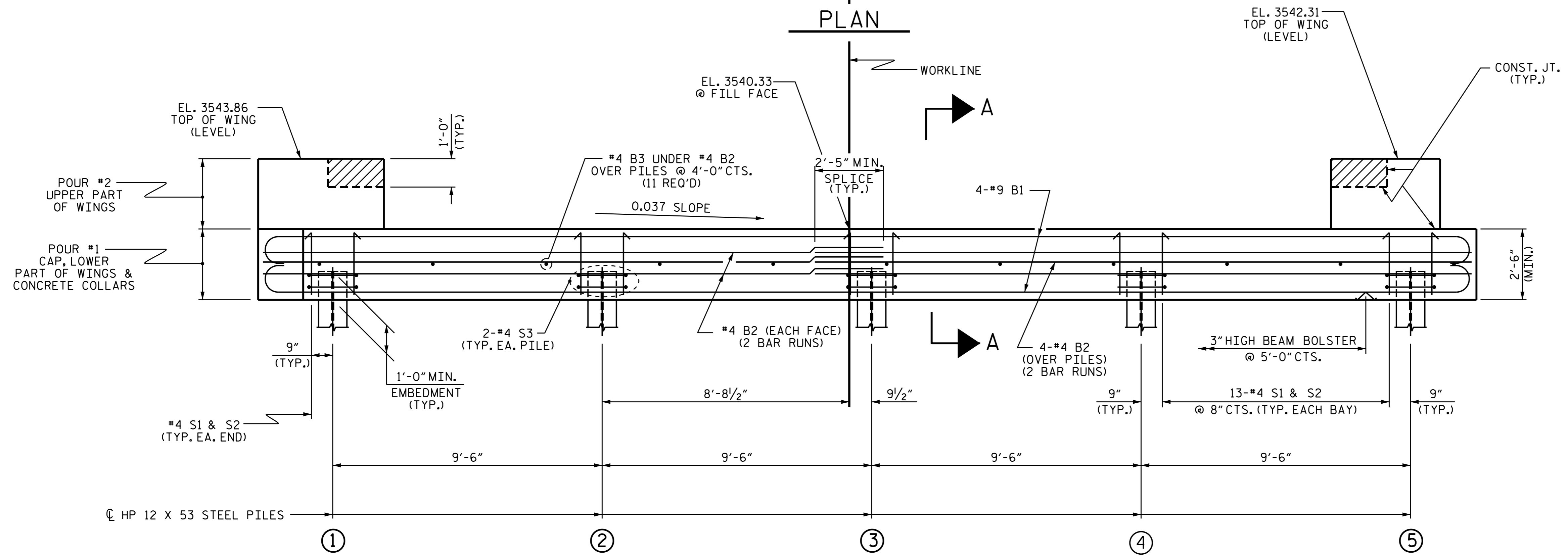

**ELEVATION**

WINGS NOT SHOWN FOR CLARITY.  
FOR SECTION A-A, SEE SHEET 4 OF 4.  
CONCRETE COLLARS FOR STEEL PILES NOT SHOWN IN PLAN AND ELEVATION VIEWS FOR CLARITY.  
SEE "CORROSION PROTECTION FOR STEEL PILES DETAIL", SHEET 4 OF 4.

TOP OF PILE ELEVATIONS	
①	3539.51
②	3539.16
③	3538.80
④	3538.45
⑤	3538.10

PROJECT NO. B-5404  
JACKSON COUNTY  
 STATION: 17+20.00-L-

SHEET 2 OF 4

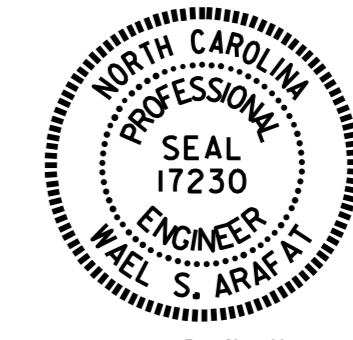

STATE OF NORTH CAROLINA DEPARTMENT OF TRANSPORTATION RALEIGH					
SUBSTRUCTURE END BENT No. 2					
REVISIONS					
NO.	BY:	DATE:	NO.	BY:	DATE:
1			3		
2			4		

ASSEMBLED BY :	H. T. BARBOUR	DATE :	4-14-15
CHECKED BY :	V. X. NGUYEN	DATE :	4-15
DRAWN BY :	DGE	01/10	REV. 4/15
CHECKED BY :	MKT	01/10	MAA/TMG

18-NOV-2015 09:31  
 Y:\Structures\FinalPlans\B5404.SD.E\*.dgn  
 warafat