

UTILITIES BY OTHERS

NOTE: ALL PROPOSED UTILITY WORK SHOWN ON THIS SHEET WILL BE DONE BY OTHERS. NO PAYMENT WILL BE MADE TO THE CONTRACTOR FOR PROPOSED UTILITY WORK SHOWN ON THIS SHEET.

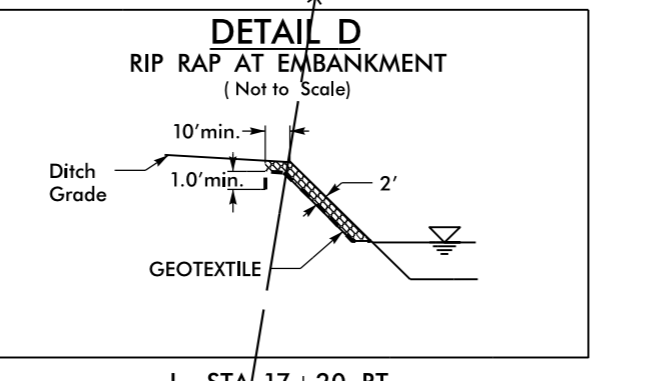
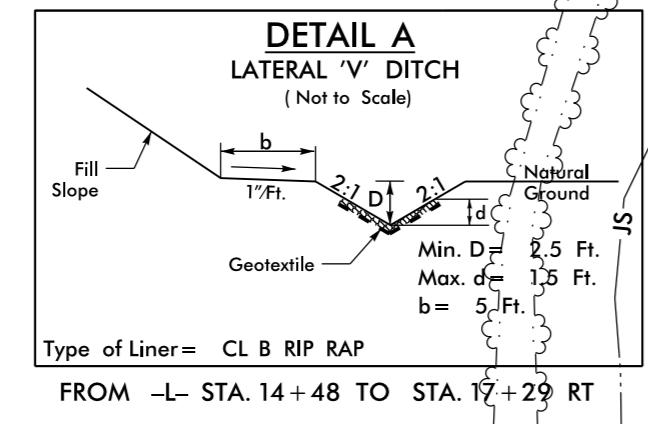
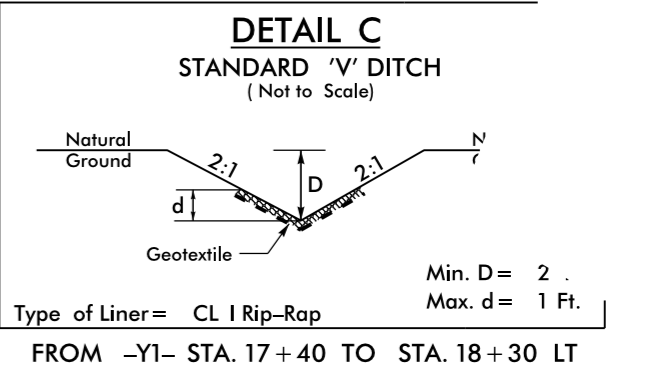
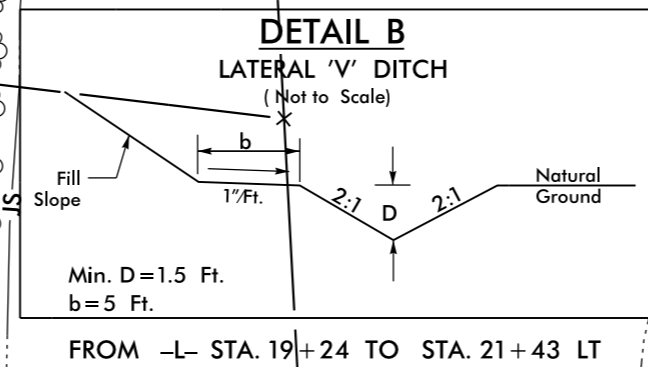
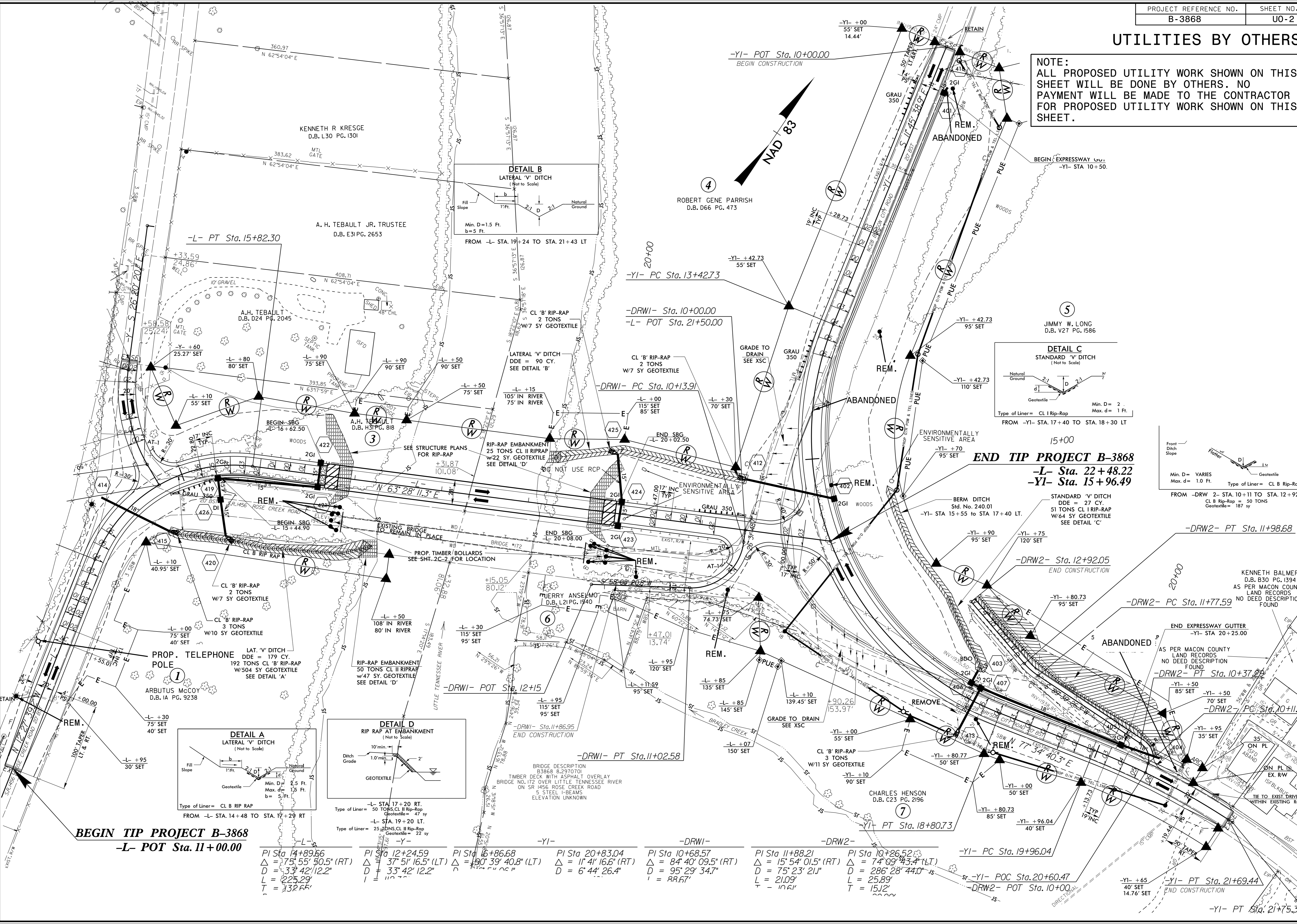

BEGIN TIP PROJECT B-3868
-L- POT Sta. 11+00.00

END TIP PROJECT B-3868
-L- Sta. 22+48.22
-YI- Sta. 15+96.49

PI Sta. 14+89.66 Δ = 75° 55' 50.5" (RT) D = 33' 42" 112.2" L = 225.29' T = 132.65'	PI Sta. 12+24.59 Δ = 37° 51' 16.5" (LT) D = 33' 42" 112.2" L = 112.65'	PI Sta. 16+86.68 Δ = 190° 39' 40.8" (LT) D = 55' 50.5" (RT) L = 112.65'	PI Sta. 20+83.04 Δ = 11° 41' 16.6" (RT) D = 6' 44" 26.4" L = 112.65'	PI Sta. 10+68.57 Δ = 84° 40' 09.5" (RT) D = 95' 29' 34.7" L = 88.67'	PI Sta. 11+88.21 Δ = 15° 54' 01.5" (RT) D = 75' 23' 21.1" L = 21.09' T = 10.61'	PI Sta. 10+26.52 Δ = 74° 09' 43.4" (LT) D = 286' 28" 44.0" L = 25.89' T = 15.2'	PI Sta. 19+96.04 Δ = 11° 41' 16.6" (RT) D = 6' 44" 26.4" L = 112.65'	PI Sta. 21+69.44 Δ = 11° 41' 16.6" (RT) D = 6' 44" 26.4" L = 112.65'	PI Sta. 21+75.31 Δ = 11° 41' 16.6" (RT) D = 6' 44" 26.4" L = 112.65'
--	---	--	---	---	---	---	---	---	---

REVISIONS

8/17/99
 5/14/99
 08-OCT-2015 14:57 U:\11\3868\B3868-Rdy-ph_04.dgn
 U:\11\3868\B3868-Rdy-ph_04.dgn