

Welded Ring Stiffened Mast Arm Connection

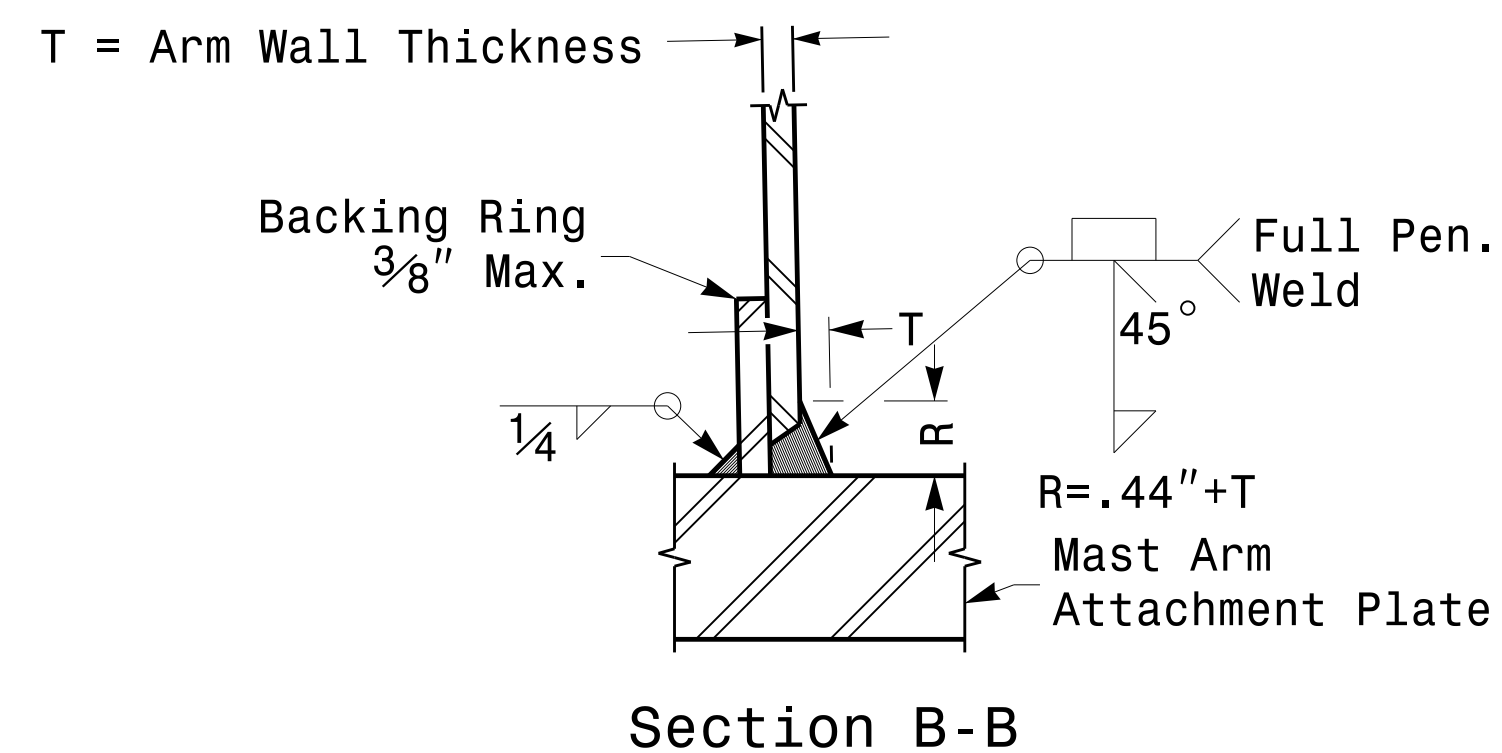
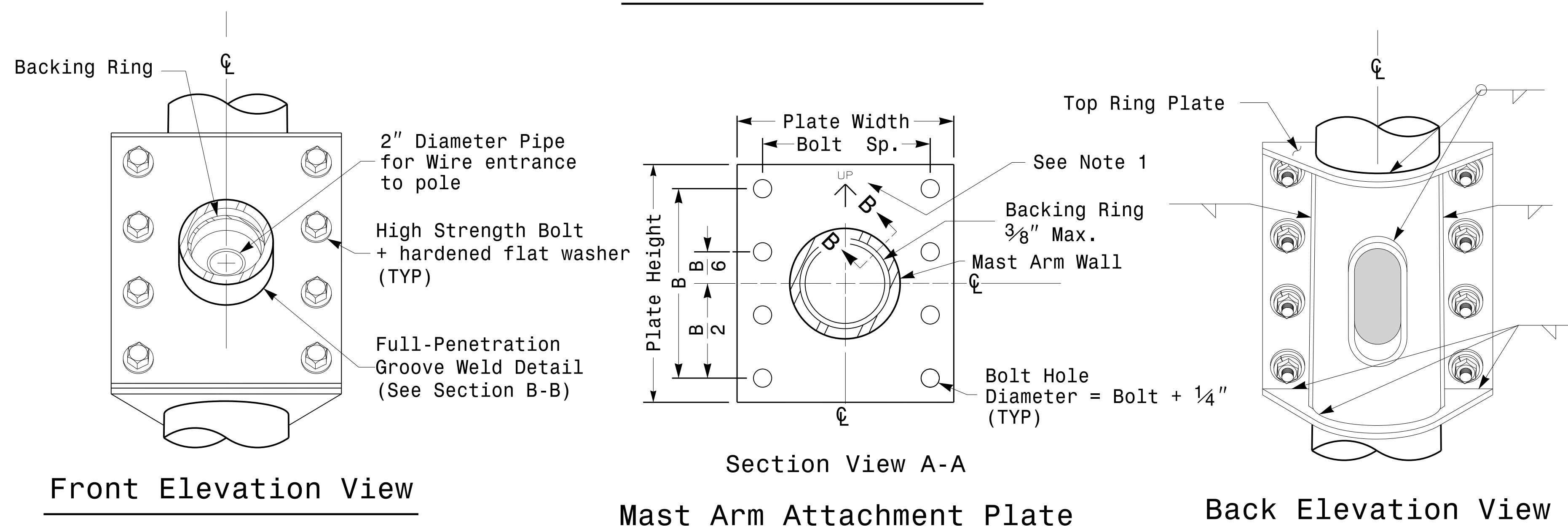
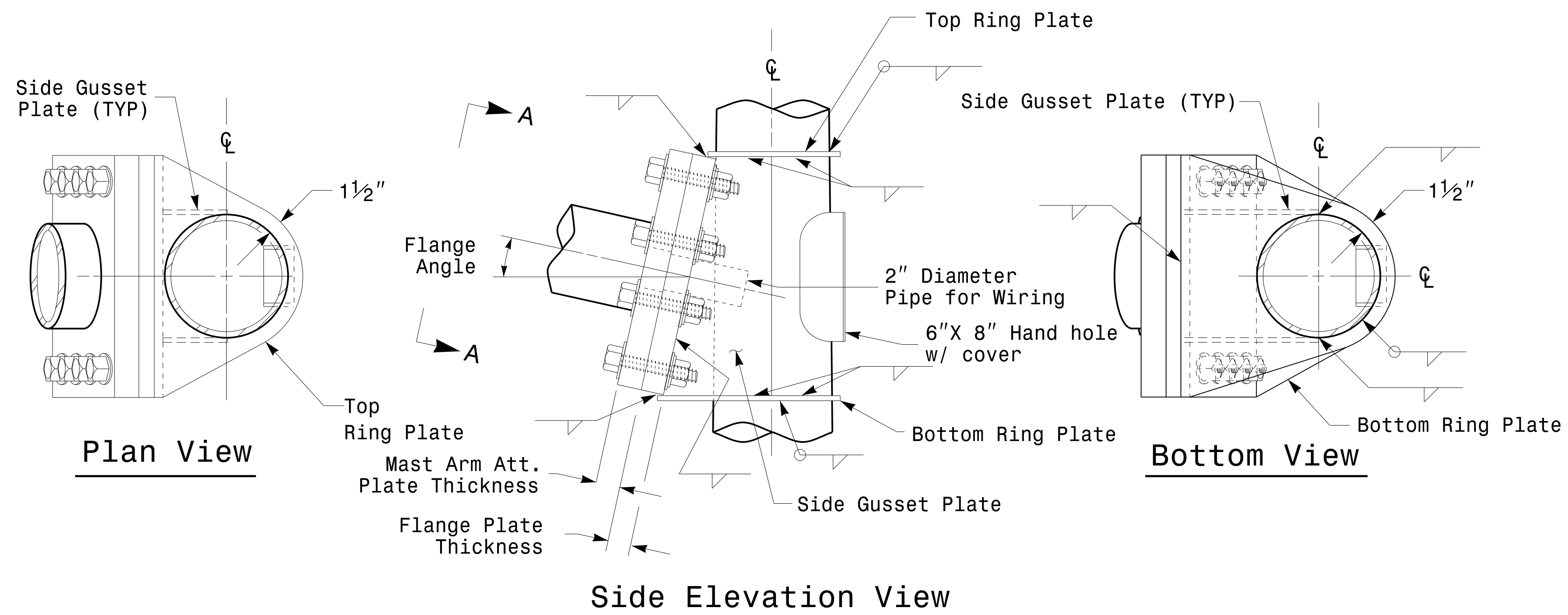

Section B-B
Full-Penetration Groove Weld Detail

Notes:

1. Provide a permanent means of identification above the mast arm to indicate proper attachment orientation of the mast arm.
2. Designer will determine the size of all structural components, plates, fasteners, and welds shown unless they are already specified.
3. Designer is responsible for providing appropriate drainage points.

	<p>Prepared In the Offices of:</p> <p>Fabrication Details For Mast Arm Connection To Pole</p>		
	<p>PLAN DATE: AUGUST 2013</p> <p>PREPARED BY: N. BITTING</p> <p>SCALE: 0 NA NONE</p>	<p>DESIGNED BY: C.F. ANDREWS</p> <p>REVIEWED BY: D.C. SARKAR</p>	

06-10-2014 08:47
 S:\Projects\2013\Signal Design\Section\Eastern Region\MM_Sheets\2012_M5_Fab_Details\MastArms.dgn
 Topiloway

Fabrication Details – Mast Arm Poles