

6/2/09

PROJECT REFERENCE NO. B-4159	SHEET NO. 2A-1
ROADWAY DESIGN ENGINEER TONY HANSEN SEAL 18494	PAVEMENT DESIGN ENGINEER BLAIR S. MORRISON SEAL 022896
10/8/2015 Designed by Tony Hansen	10/12/2015 Designed by Blair S. Morrison

PAVEMENT SCHEDULE	
A	6" JOINTED CONCRETE WITHOUT DOWELS, REINFORCED 4X4 W3 X W3 WIRE MESH.
C1	PROP. APPROX. 1 1/2" ASPHALT CONCRETE SURFACE COURSE, TYPE S9.5B, AT AN AVERAGE RATE OF 168 LBS. PER SQ. YD.
C2	PROP. APPROX. 3" ASPHALT CONCRETE SURFACE COURSE TYPE S9.5B, AT AN AVERAGE RATE OF 168 LBS. PER SQ. YD. IN EACH OF TWO LAYERS.
C3	PROP. VAR. DEPTH ASPHALT CONCRETE SURFACE COURSE, TYPE S9.5B, AT AN AVERAGE RATE OF 112 LBS. PER SQ. YD. PER 1" DEPTH. TO BE PLACED IN LAYERS NOT LESS THAN 1 1/2" OR GREATER THAN 2" IN DEPTH.
D1	PROP. APPROX. 2.5" ASPHALT CONCRETE INTERMEDIATE COURSE, TYPE I19.0B, AT AN AVERAGE RATE OF 285 LBS. PER SQ. YD.
D2	PROP. APPROX. 4" ASPHALT CONCRETE INTERMEDIATE COURSE, TYPE I19.0B, AT AN AVERAGE RATE OF 456 LBS. PER SQ. YD.
D3	PROP. VAR. DEPTH ASPHALT CONCRETE SURFACE COURSE, TYPE I19.0B, AT AN AVERAGE RATE OF 114 LBS. PER SQ. YD. PER 1" DEPTH. TO BE PLACED IN LAYERS NOT LESS THAN 2 1/2" OR GREATER THAN 4" IN DEPTH.
E1	PROP. APPROX. 4" ASPHALT CONCRETE BASE COURSE, TYPE B25.0B, AT AN AVERAGE RATE OF 456 LBS. PER SQ. YD.
E2	PROP. APPROX. 4.5" ASPHALT CONCRETE BASE COURSE, TYPE B25.0B, AT AN AVERAGE RATE OF 513 LBS. PER SQ. YD.
E3	PROP. APPROX. 5" ASPHALT CONCRETE BASE COURSE, TYPE B25.0B, AT AN AVERAGE RATE OF 570 LBS. PER SQ. YD.
E4	PROP. VAR. DEPTH ASPHALT CONCRETE BASE COURSE, TYPE B25.0B, AT AN AVERAGE RATE OF 114 LBS. PER SQ. YD. PER 1" DEPTH. TO BE PLACED IN LAYERS NOT LESS THAN 4" IN DEPTH OR GREATER THAN 5 1/2" IN DEPTH.
J	PROP. 4" AGGREGATE BASE COURSE.
R1	2'-6" CONCRETE CURB & GUTTER.
R2	8"X 18" CONCRETE CURB.
S	5' SIDEWALK
T	EARTH MATERIAL.
U	EXISTING PAVEMENT.
W	VARIABLE DEPTH ASPHALT PAVEMENT (SEE WEDGING DETAIL).

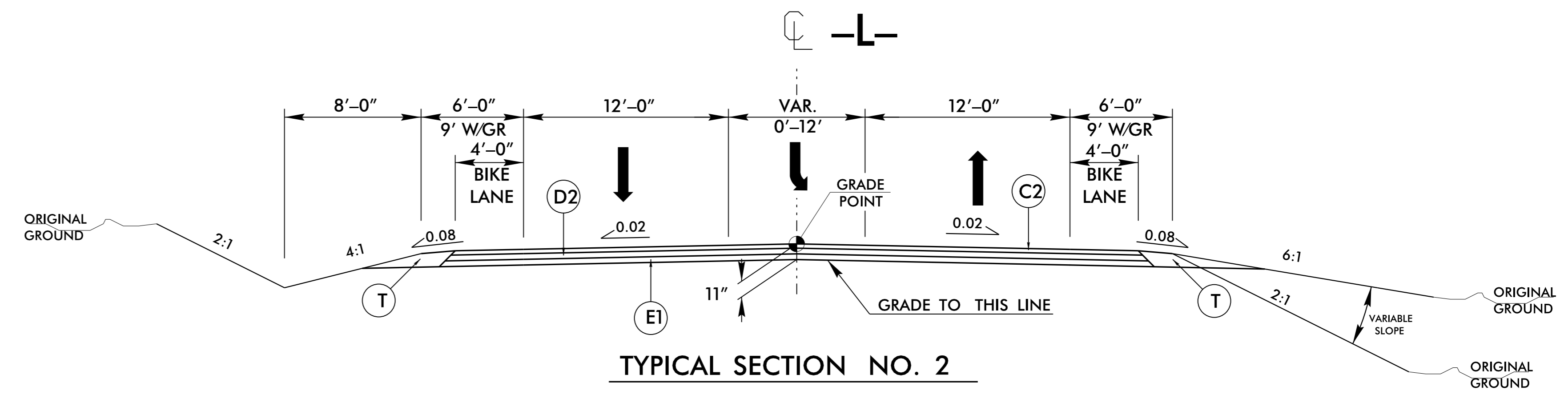
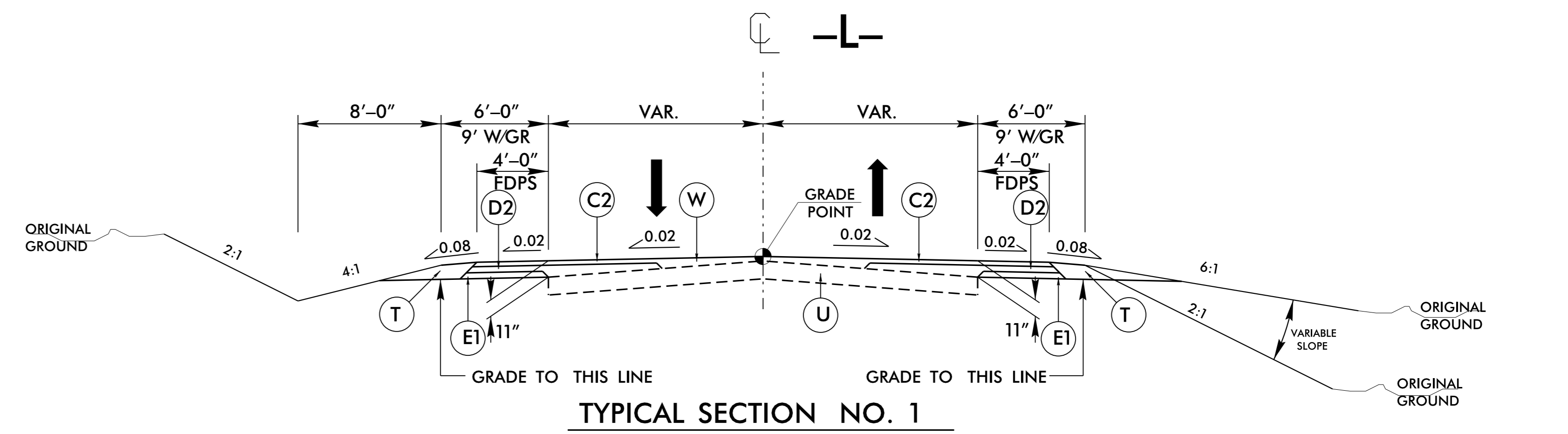
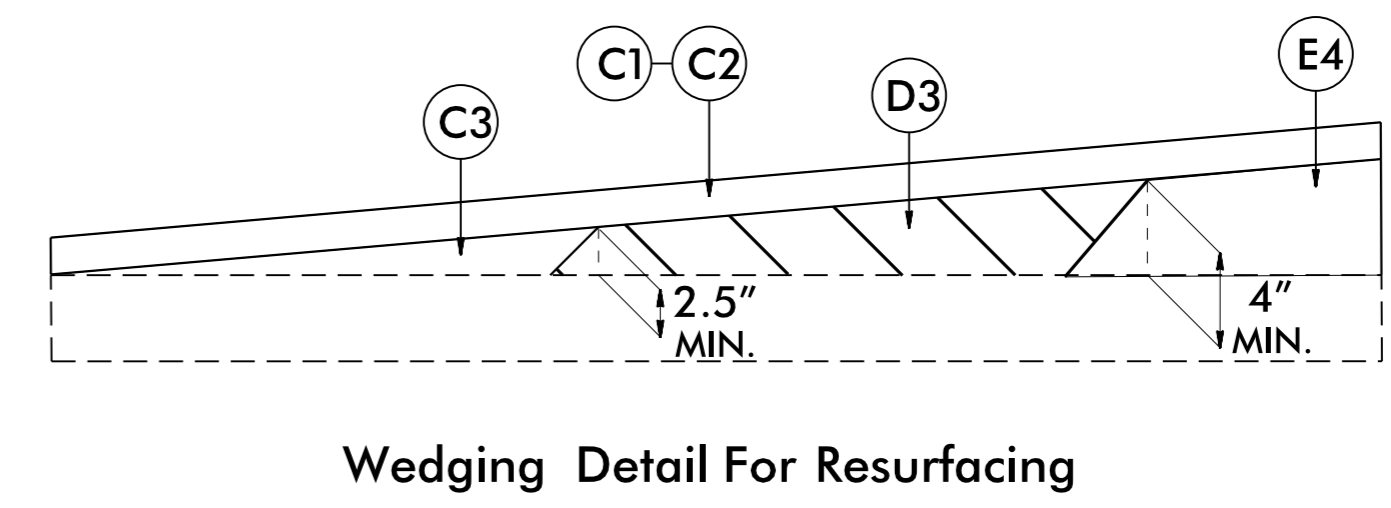
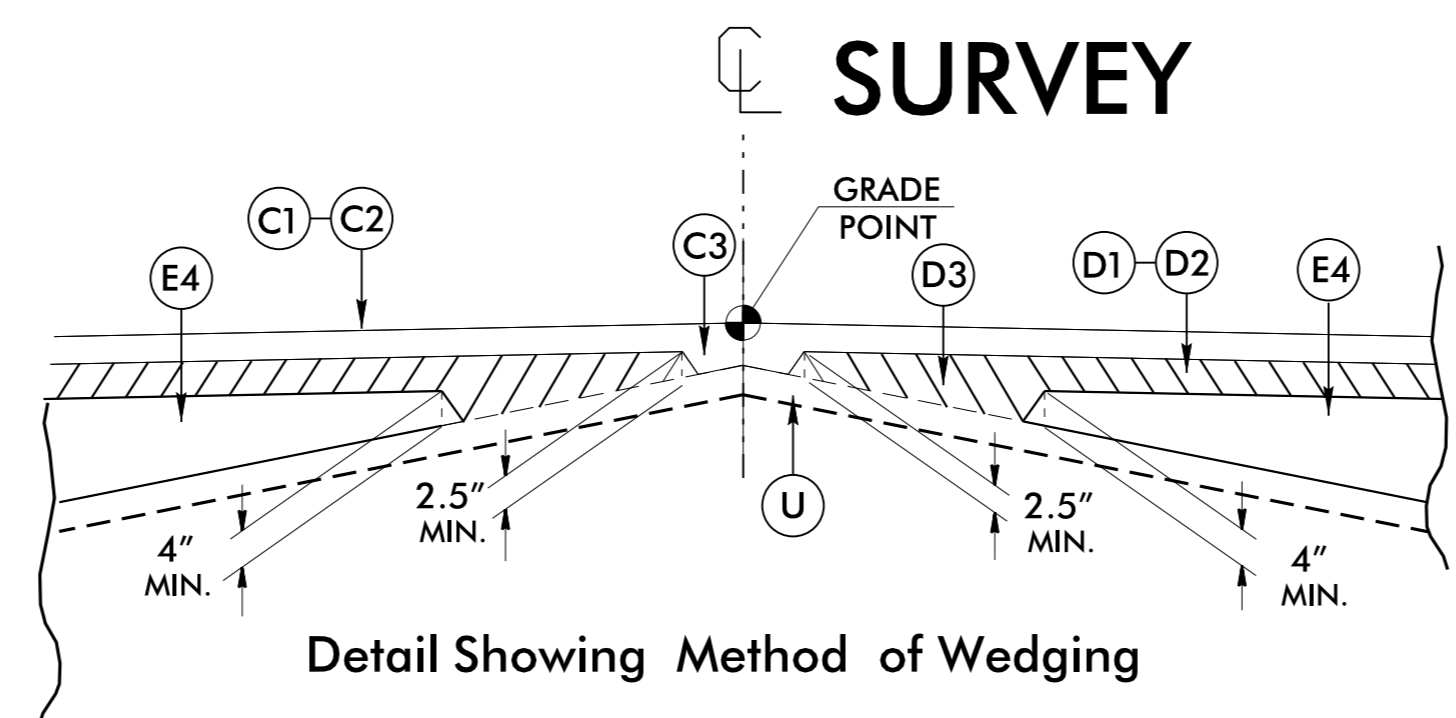

NOTE: PAVEMENT EDGE SLOPES ARE 1:1 UNLESS SHOWN OTHERWISE.

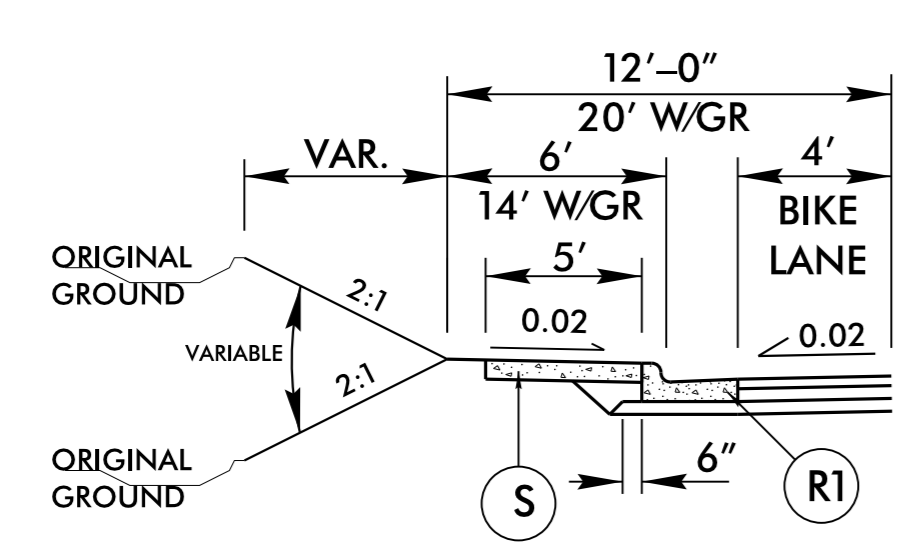

TYPICAL SECTION NO. 2A
USE IN CONJUNCTION WITH NO. 2

-L- STA. 15+75.00 TO STA. 16+39.22 LT
-L- STA. 17+14.96 TO STA. 18+69.64 LT
-L- STA. 24+34.12 TO STA. 25+12.55 LT

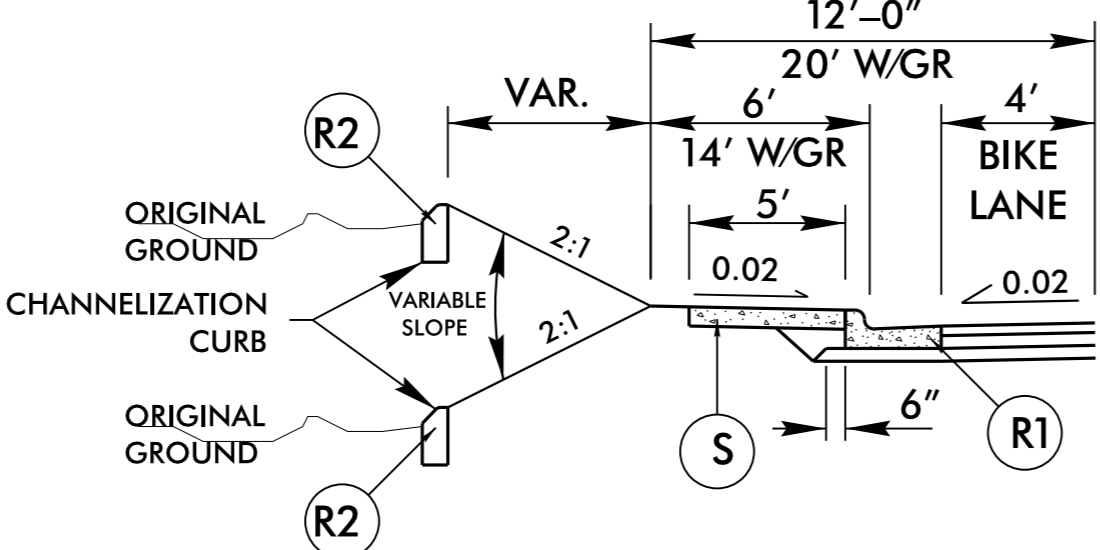

TYPICAL SECTION NO. 2B
USE IN CONJUNCTION WITH NO. 2

-L- STA. 16+39.22 TO STA. 17+14.96 LT

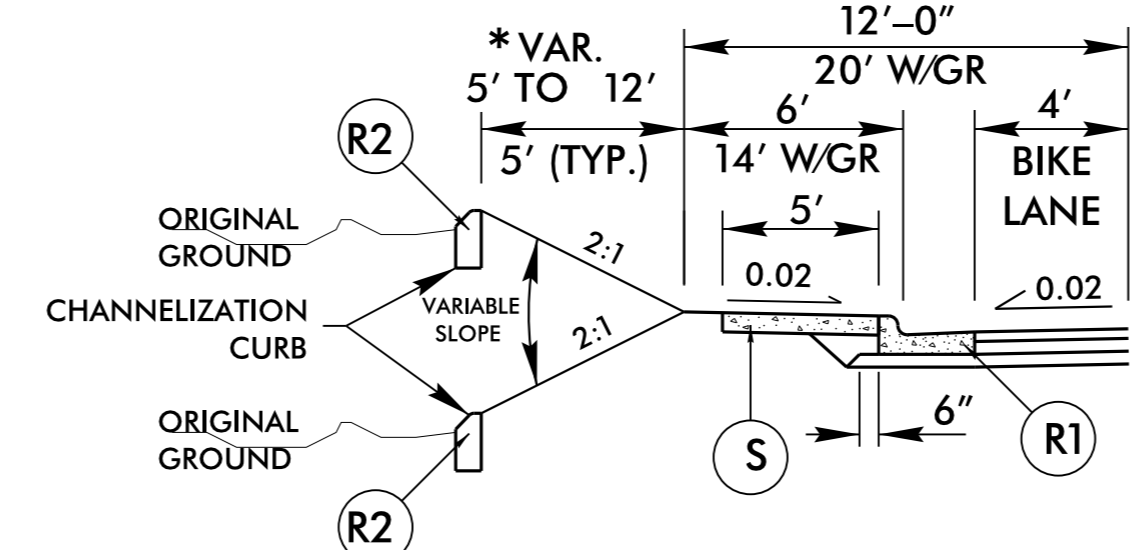

TYPICAL SECTION NO. 2C
USE IN CONJUNCTION WITH NO. 2

*-L- STA. 21+95.50 TO STA. 23+27.88 LT
-L- STA. 23+27.88 TO STA. 24+34.12 LT
-L- STA. 25+12.55 TO STA. 28+60.00 LT

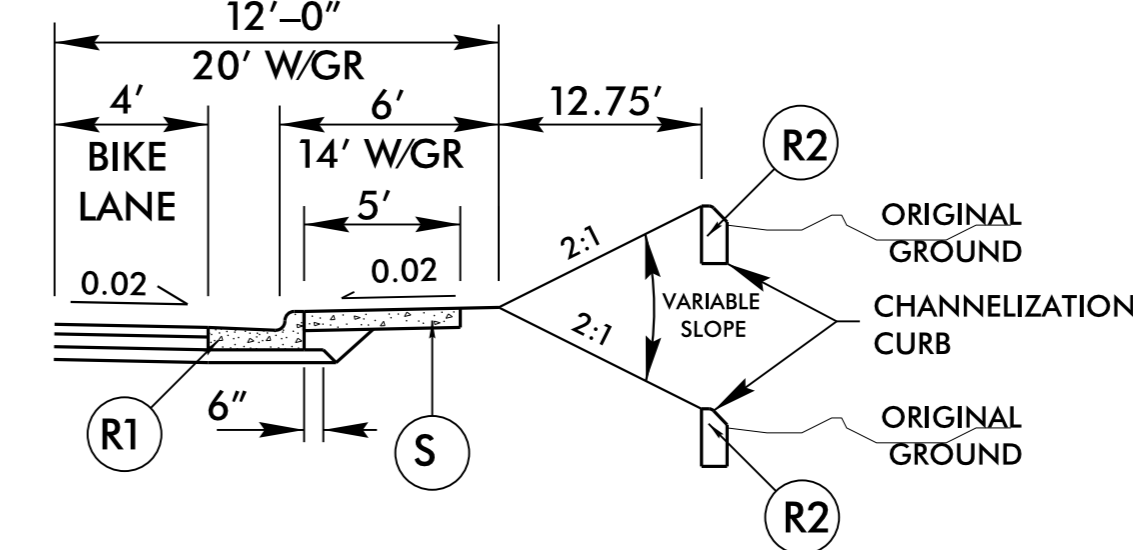

TYPICAL SECTION NO. 2D
USE IN CONJUNCTION WITH NO. 2

-L- STA. 17+24.50 TO STA. 18+44.74 RT

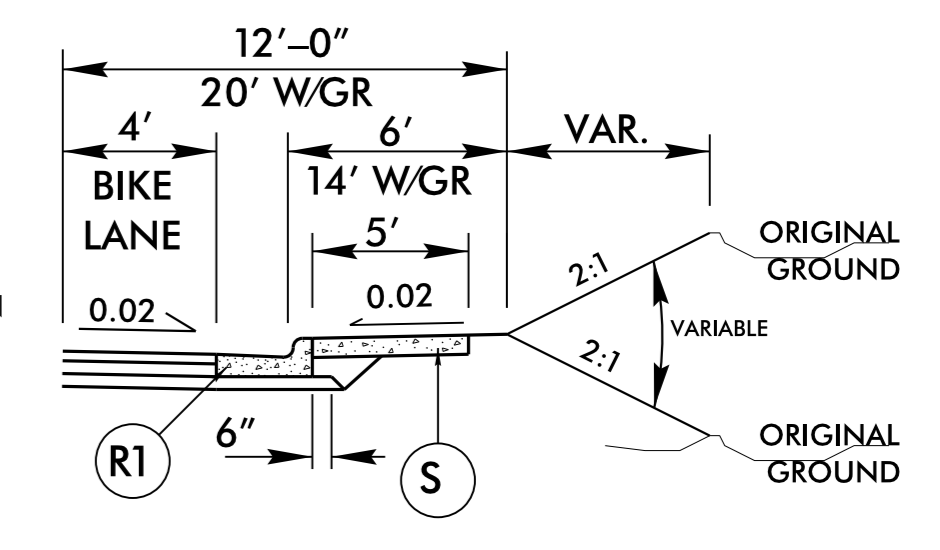

TYPICAL SECTION NO. 2E
USE IN CONJUNCTION WITH NO. 2

-L- STA. 21+71.12 TO STA. 22+41.06 RT

02-OCT-2015 09:41:11:1:Preferred\64159_rdy_tup.dgn