

**This electronic collection of documents is provided  
for the convenience of the user  
and is Not a Certified Document –**

**The documents contained herein were originally issued  
and sealed by the individuals whose names and license  
numbers appear on each page, on the dates appearing  
with their signature on that page.**

**This file or an individual page  
shall not be considered a certified document.**

**T.I.P.: W-5206AM**

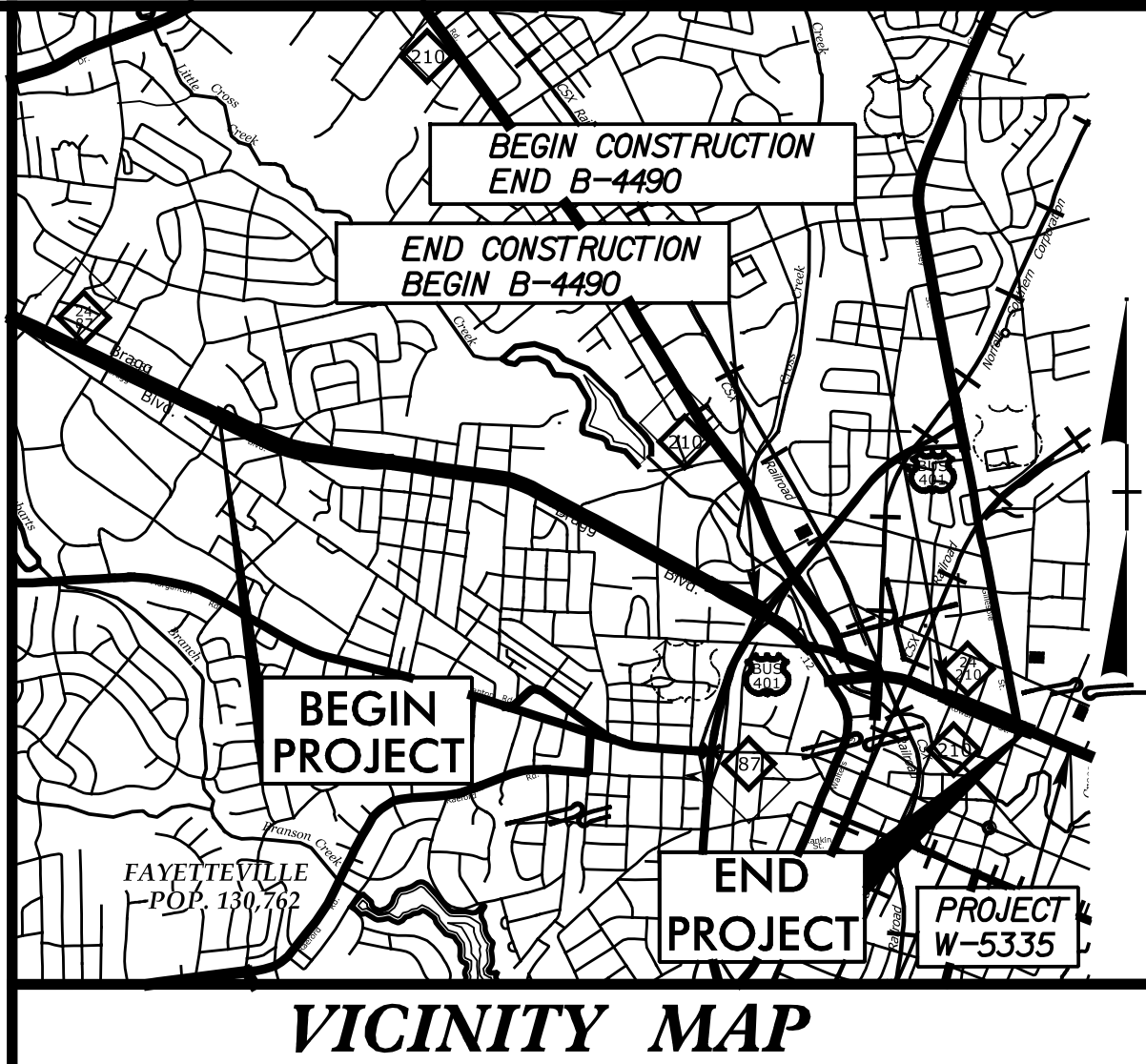

**VICINITY MAP**

**STATE OF NORTH CAROLINA  
DEPARTMENT OF TRANSPORTATION**

**PAVEMENT MARKING PLAN  
CUMBERLAND COUNTY**

**LOCATION: NC 24/NC87 FROM BARRINGTON CROSS STREET TO EAST OF  
MARTIN LUTHER KING WESTBOUND RAMPS; AND NC 24/  
NC 210 (ROWAN STREET) BETWEEN RAY AVENUE  
AND RAMSEY STREET**

<b>TIP NO.</b> W-5206AM	<b>SHEET NO.</b> PMP-1
APPROVED: <u>Steven Miller</u> <small>DESIGNED BY</small>	
DATE: 9/25/2015	

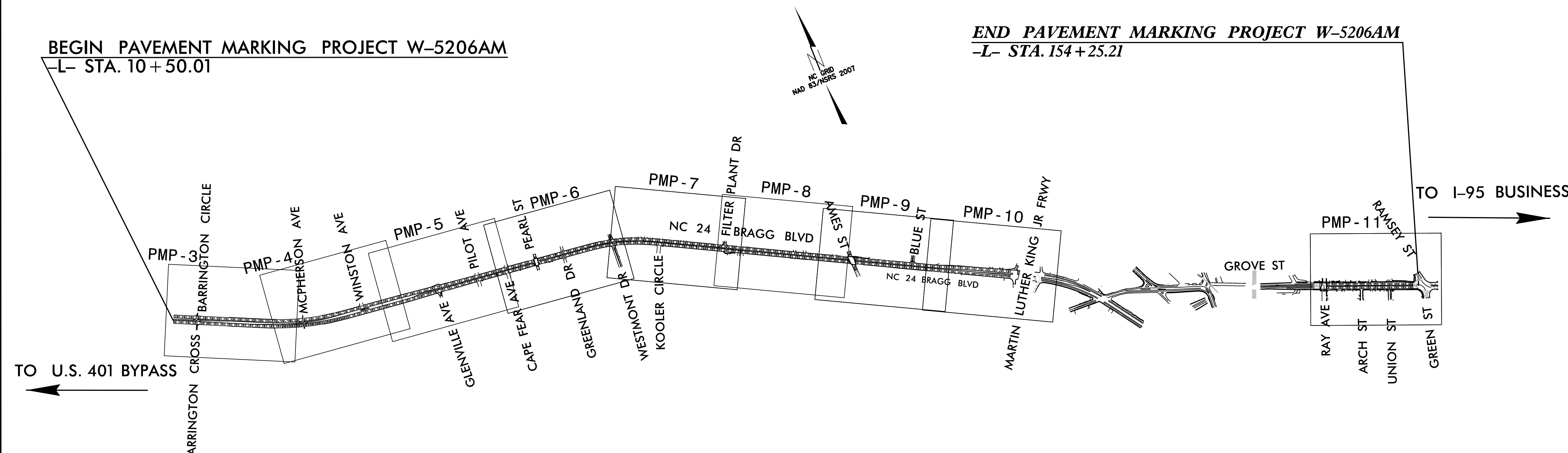

**PLAN PREPARED BY: SEPI ENGINEERING & CONSTRUCTION**

STEVEN D MILLER, PE SIGNING & DELINEATION PROJECT ENGINEER  
RICHARD DRAYTON SIGNING & DELINEATION PROJECT DESIGN ENGINEER

**NCDOT CONTACTS:**

AYMAN I. ALQUDWAH, PE SIGNING & DELINEATION REGIONAL ENGINEER  
D. M. EATON SIGNING & DELINEATION PROJECT DESIGN ENGINEER

<b>INDEX</b>	
<u>SHEET NO.</u>	<u>DESCRIPTION</u>
PMP-1	PAVEMENT MARKING PLAN TITLE SHEET
PMP-1A	SCHEDULE, NOTES AND RSD SCHEDULE SHEET
PMP-2	REVISED PAVEMENT MARKING ROADWAY STANDARD DRAWING DETAIL
PMP-3-11	PAVEMENT MARKING DETAIL

TIP NO.	SHEET NO.
W-5206AM	PMP-1A
APPROVED: <u>Steve Miller</u> <small>DocuSigned by: #F58C1CE8E848</small>	
DATE: 9/25/2015	
SEAL	



**PAVEMENT MARKING SCHEDULE**

SYMBOL	DESCRIPTION	
TU	WHITE DIAGONAL	<u>THERMOPLASTIC(12", 90 MILS)</u>
		<u>THERMOPLASTIC(24", 120 MILS)</u>
T2	WHITE STOPBAR	
T3	WHITE CROSSWALK LINE	
		<u>THERMOPLASTIC(4", 120 MILS)</u>
T8	2 FT. - 6 FT./SP WHITE MINISKIP	
T9	2 FT. - 6 FT./SP YELLOW MINISKIP	
TC	10 FT. WHITE SKIP	
TD	3 FT. - 9 FT./SP WHITE MINISKIP	
TE	WHITE SOLID LANE LINE	
TI	YELLOW DOUBLE CENTER	
		<u>THERMOPLASTIC(4", 90 MILS)</u>
TA	WHITE EDGELINE	
TB	YELLOW EDGELINE	
		<u>THERMOPLASTIC(8", 90 MILS)</u>
TN	WHITE GORELINE	
TP	YELLOW DIAGONAL	
		<u>THERMOPLASTIC PAVEMENT MARKING SYMBOLS (90 MILS)</u>
UA	LEFT TURN ARROW	
UB	RIGHT TURN ARROW	
UC	STRAIGHT ARROW	
UE	COMBO.STRAIGHT/RIGHT	
UT	U-TURN ARROW	
		<u>SNOWPLOWABLE RAISED PAVEMENT MARKERS</u>
ME	YELLOW & YELLOW	
MF	CRYSTAL & RED	

**GENERAL NOTES**

- THE FOLLOWING GENERAL NOTES APPLY AT ALL TIMES FOR THE DURATION OF THE CONSTRUCTION PROJECT, EXCEPT WHEN OTHERWISE NOTED IN THE PLAN, OR DIRECTED BY THE ENGINEER.
- A) INSTALL PAVEMENT MARKINGS AND PAVEMENT MARKERS ON THE FINAL SURFACE AS FOLLOWS:
 

ROAD NAME	MARKING	MARKER
NC24/NC87(BRAGG BLVD)	THERMOPLASTIC	SNOWPLOWABLE RAISED
NC24/NC210	THERMOPLASTIC	SNOWPLOWABLE RAISED
-Y- LINES	THERMOPLASTIC	SNOWPLOWABLE RAISED
  - B) TIE PROPOSED PAVEMENT MARKING LINES TO EXISTING PAVEMENT MARKING LINES.
  - C) REMOVE/REPLACE ANY CONFLICTING/DAMAGED PAVEMENT MARKINGS AND MARKERS.
  - D) PASSING ZONES WILL BE DETERMINED IN THE FIELD AND MUST BE APPROVED BY THE ENGINEER.
  - E) STOP BAR LOCATION AT NON-SIGNALIZED INTERSECTIONS MAY BE ADJUSTED AS DIRECTED BY THE ENGINEER.
  - F) UNLESS OTHERWISE SPECIFIED, HEATED-IN-PLACE THERMOPLASTIC MAY BE USED IN LIEU OF EXTRUDED THERMOPLASTIC FOR STOP BARS, SYMBOLS, CHARACTERS AND DIAGONALS. IF HEATED-IN-PLACE IS USED, IT SHALL BE PAID FOR USING THE EXTRUDED THERMOPLASTIC PAY ITEM.

**ROADWAY STANDARD DRAWING**

- THE FOLLOWING ROADWAY STANDARDS AS APPEAR IN "ROADWAY STANDARD DRAWINGS" - PROJECT SERVICES UNIT - N.C. DEPARTMENT OF TRANSPORTATION - RALEIGH, N.C., DATED JANUARY 2012 ARE APPLICABLE TO THIS PROJECT AND BY REFERENCE HEREBY ARE CONSIDERED A PART OF THESE PLANS:
- | STD. NO. | TITLE  |
|----------|--|
| 1205.01  | PAVEMENT MARKINGS - LINE TYPES AND OFFSETS               |
| 1205.02  | PAVEMENT MARKINGS - TWO-LANE AND MULTILANE ROADWAYS      |
| 1205.04  | PAVEMENT MARKINGS - INTERSECTIONS                        |
| 1205.05  | PAVEMENT MARKINGS - TURN LANES                           |
| 1205.09  | PAVEMENT MARKINGS - PAINTED ISLANDS                      |
| 1250.01  | RAISED PAVEMENT MARKERS - INSTALLATION SPACING           |
| 1253.01  | RAISED PAVEMENT MARKERS - SNOWPLOWABLE                   |
| 1261.01  | GUARDRAIL AND BARRIER DELINEATORS - INSTALLATION SPACING |
| 1261.02  | GUARDRAIL AND BARRIER DELINEATORS - TYPES AND MOUNTING   |

TIP NO. W-5206AM	SHEET NO. PMP-2
APPROVED: _____	
DATE: _____	
SEAL	
	
REVISIONS	

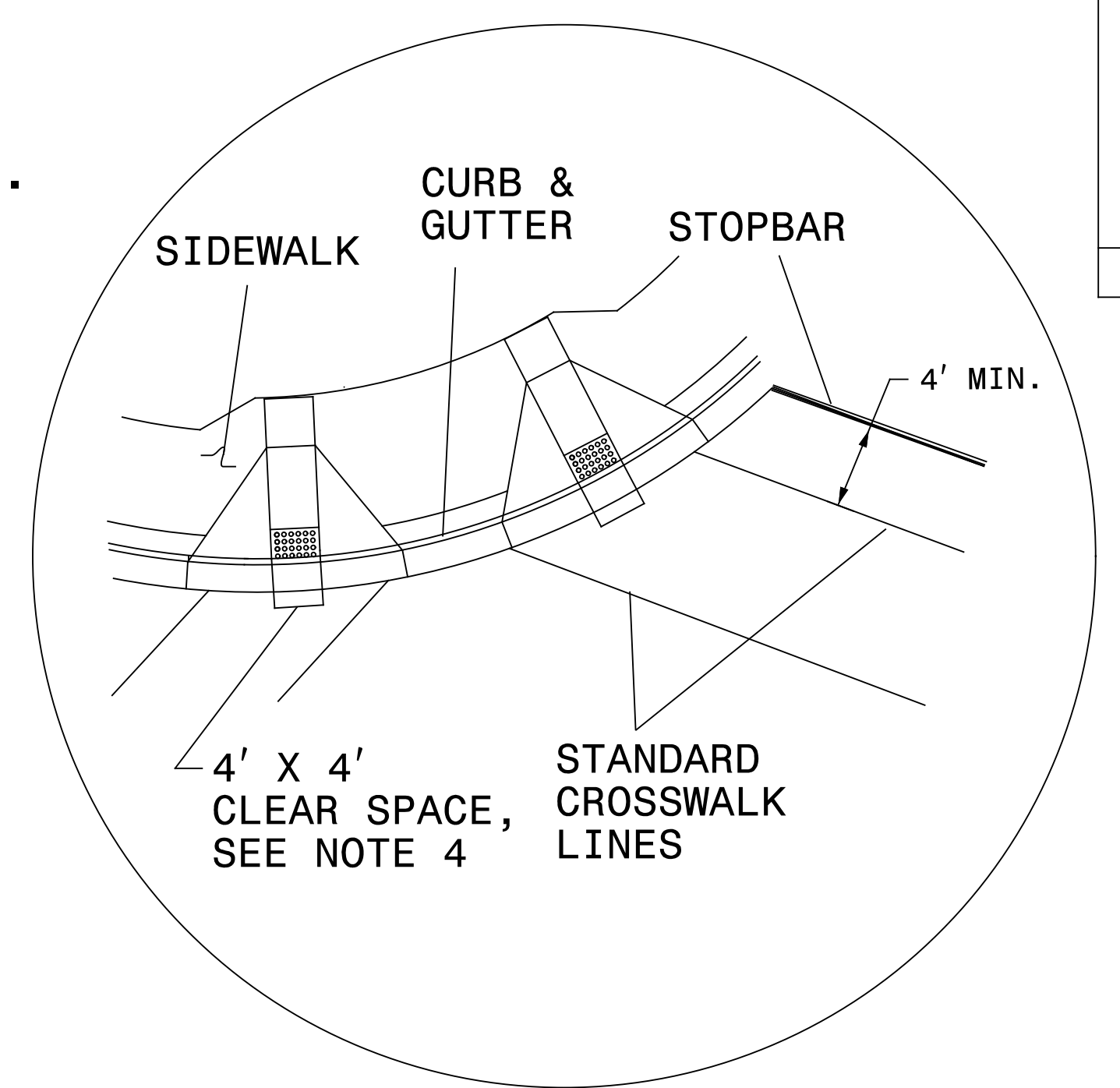
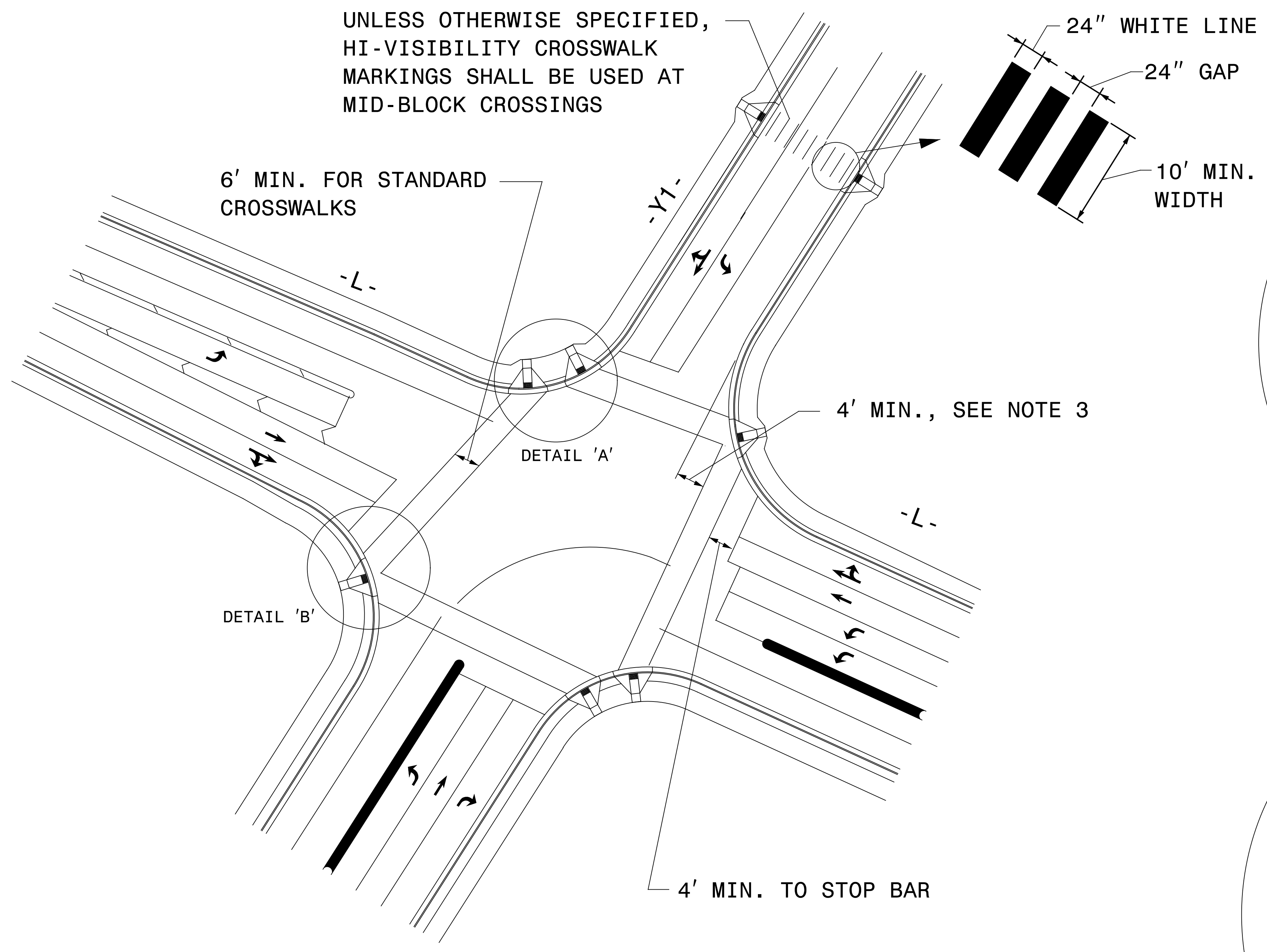

DETAIL 'A'- DUAL CURB RAMPS

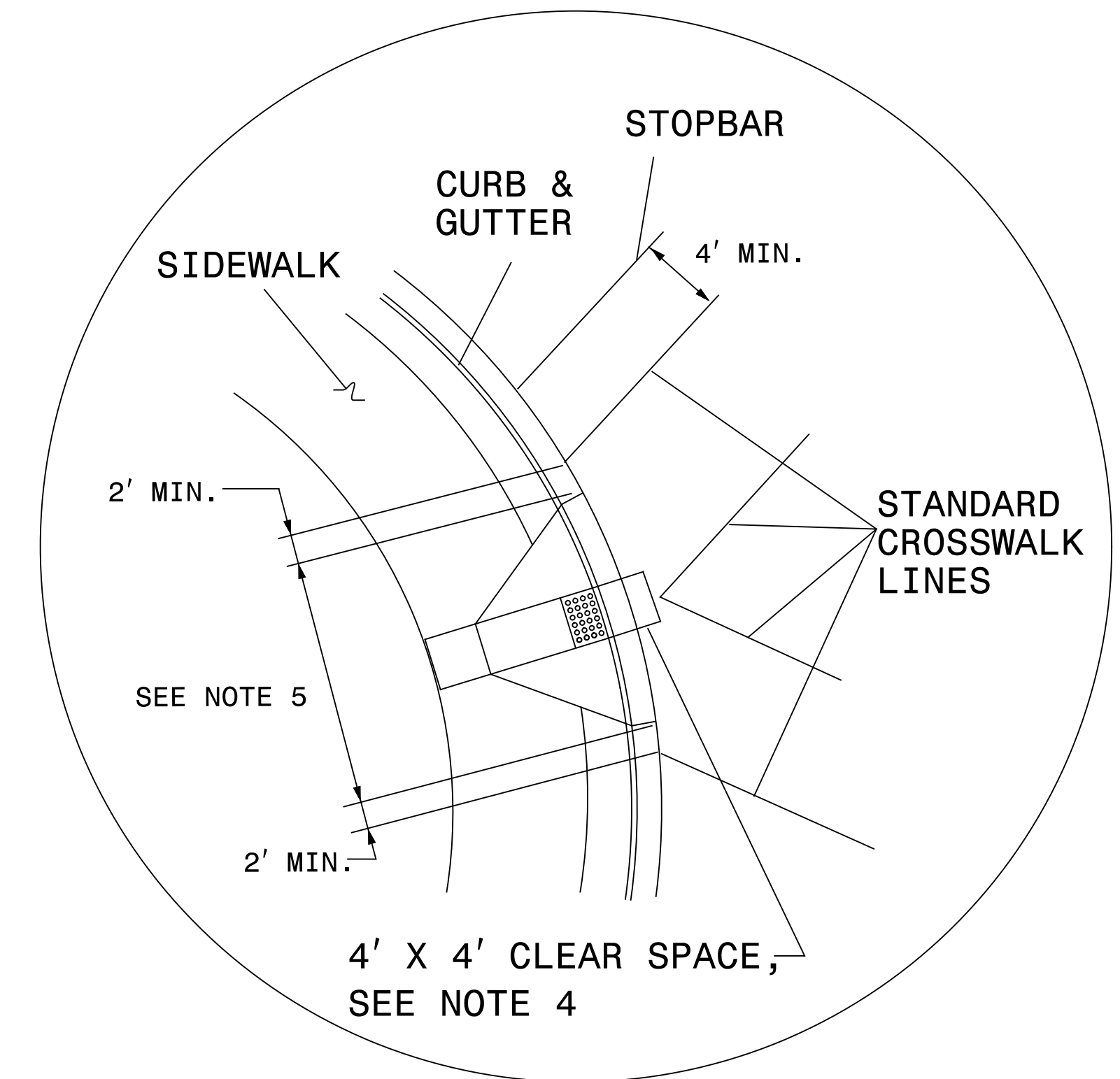

DETAIL 'B'- SINGLE DIAGONAL CURB RAMP



**GUIDANCE DETAIL FOR CROSSWALK MARKINGS**

**NOTES:**

1. USE THE DETAILS ABOVE AND THE FOLLOWING NOTES FOR GUIDANCE IN PLACING CROSSWALK MARKINGS NOT STATIONED ON THE DETAIL SHEETS OR WHEN FIELD ADJUSTMENTS REQUIRED MOVING STATIONED MARKINGS AS DIRECTED BY THE ENGINEER. REFER TO NCDOT ROADWAY STANDARD DRAWINGS, MUTCD AND ADA STANDARDS FOR ADDITIONAL GUIDANCE.
2. THE CROSSWALK MARKINGS SHOWN ON THE ABOVE DETAILS ARE FOR REFERENCE ONLY. ONLY INSTALL CROSSWALK MARKINGS WHERE SHOWN ON THE DETAIL SHEETS OR AS DIRECTED BY THE ENGINEER. THE CROSSWALK MARKING TYPE, STANDARD OR HI-VISIBILITY, SHALL BE INSTALL AS SPECIFIED ON THE DETAIL SHEETS OR AS DIRECTED BY THE ENGINEER.
3. SET BACK DISTANCE FROM INSIDE CROSSWALK MARKING TO NEAREST EDGE OF TRAVEL IS 4' MIN.
4. BEYOND THE BOTTOM GRADE BRAKE, A CLEAR SPACE OF 4' X 4' MINIMUM SHALL BE PROVIDED WITHIN THE MARKINGS.
5. SINGLE DIAGONAL CURB RAMPS WITH FLARED SIDES SHALL HAVE A SEGMENT OF CURB 2 FEET LONG MINIMUM LOCATED ON EACH SIDE OF THE CURB RAMP AND WITHIN THE MARKED CROSSING, SEE DETAIL 'B'.
6. CURB RAMPS SHALL BE CONSTRUCTED IN ACCORDANCE TO THE LATEST NCDOT ROADWAY STANDARD DRAWINGS.

**CROSSWALK PAVEMENT MARKING GUIDANCE DETAIL**

9/14/2015 9:41:00 AM C:\TranSPORTATION\TR14\011.00 W-5206AM\ Pavement\ Marking\ PMP-2.dgn jwiles

PROJECT REFERENCE NO. W-5206AM	SHEET NO. PMP-3
APPROVED:  9/25/2015	
DATE: 9/25/2015	
SEAL	
	

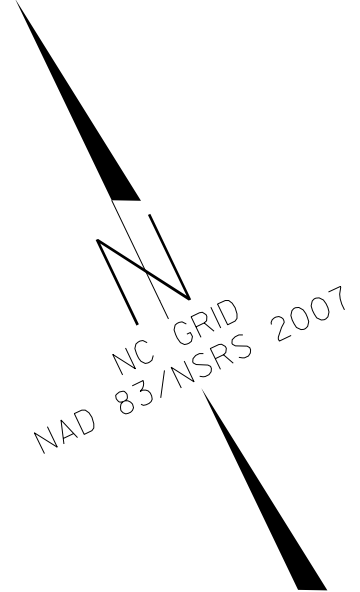

BEGIN PROJECT W-5206AM  
-L- POT STA. 10+50.01

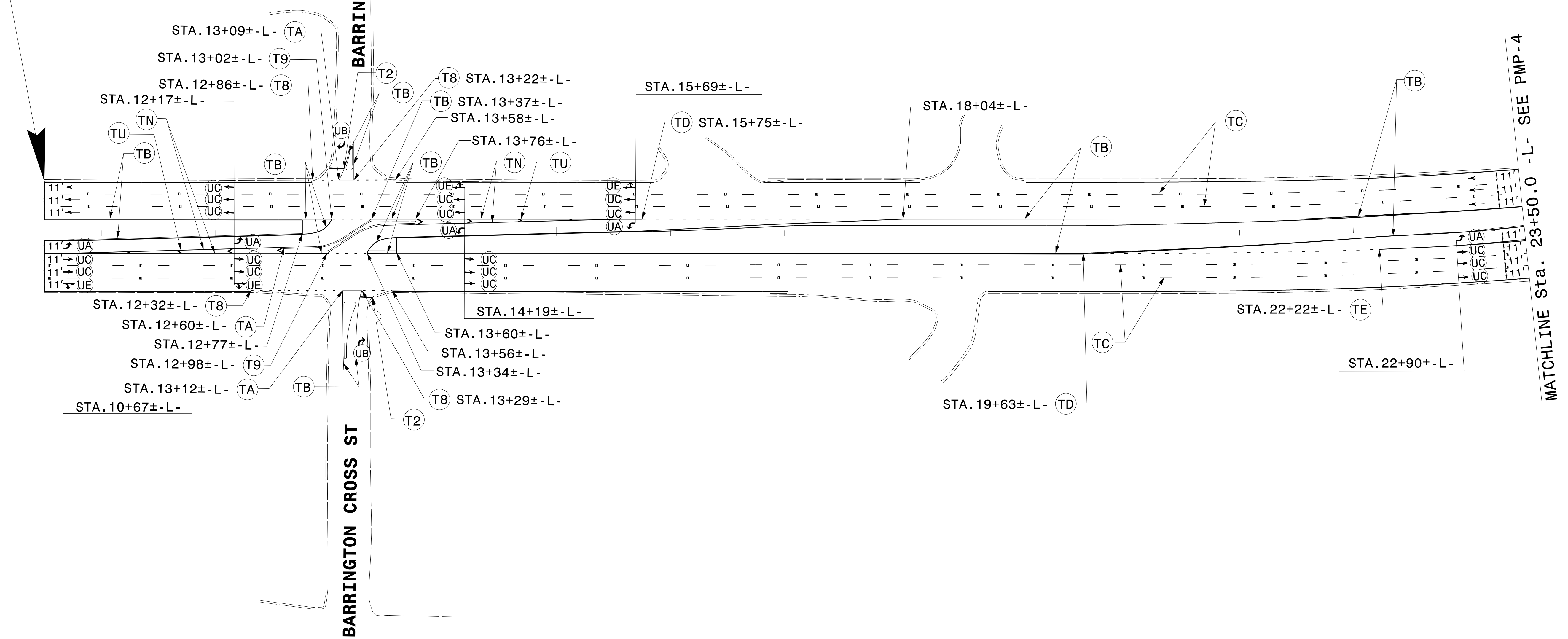

SYSTEMS DESIGN  
CONSULTANTS  
INCORPORATED

**PAVEMENT MARKING DETAIL**

PROJECT REFERENCE NO. W-5206AM	SHEET NO. PMP-4
APPROVED: <i>Steve Miller</i> 9FB0C015CEE8486	
DATE: 9/25/2015	
SEAL	

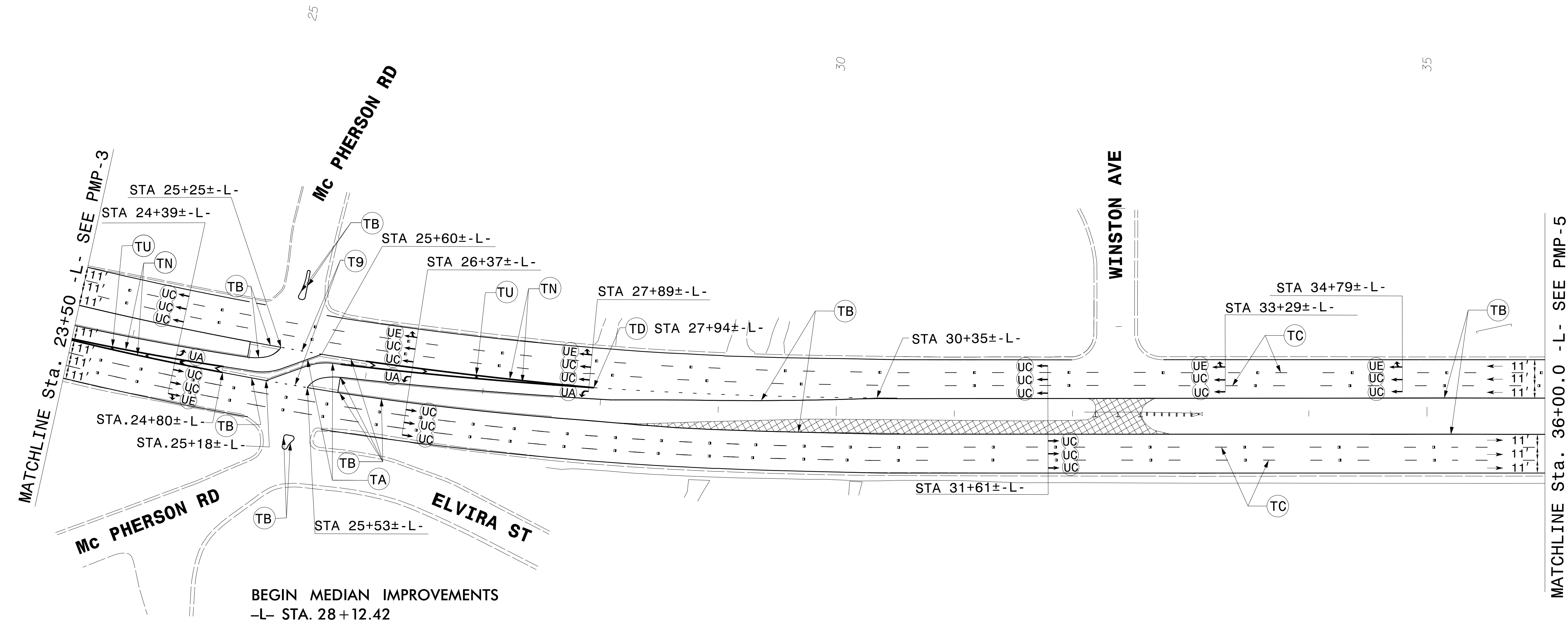
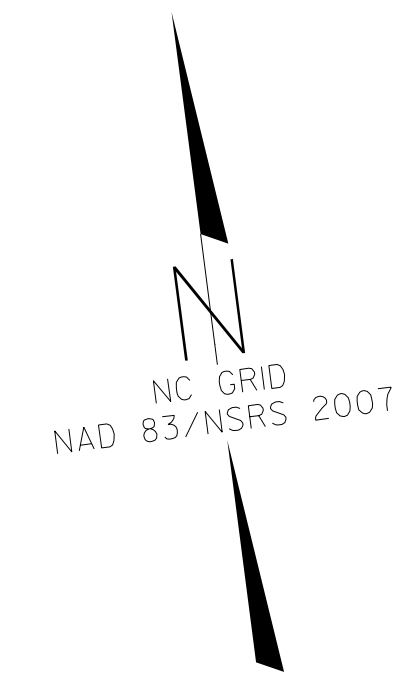

SYSTEMS  
 DESIGN  
 CONSULTANTS  
 P.C.

**PAVEMENT MARKING DETAIL**

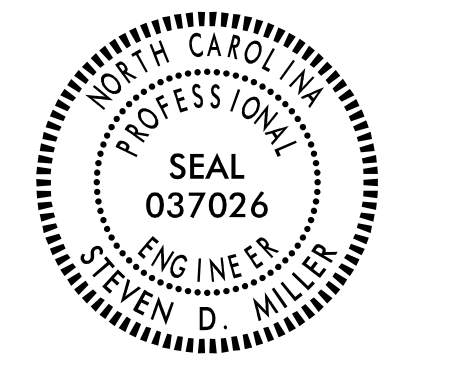
PROJECT REFERENCE NO.	SHEET NO.
W-5206AM	PMP-5
APPROVED: <i>Steve Miller</i> 9/25/2015	
DATE: 9/25/2015	
SEAL	
	

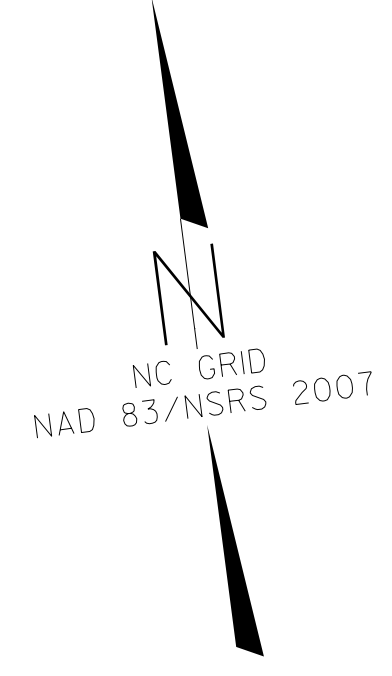

MATCHLINE Sta. 36+00.0 -L- SEE PMP-4

MATCHLINE Sta. 49+00.0 -L- SEE PMP-6

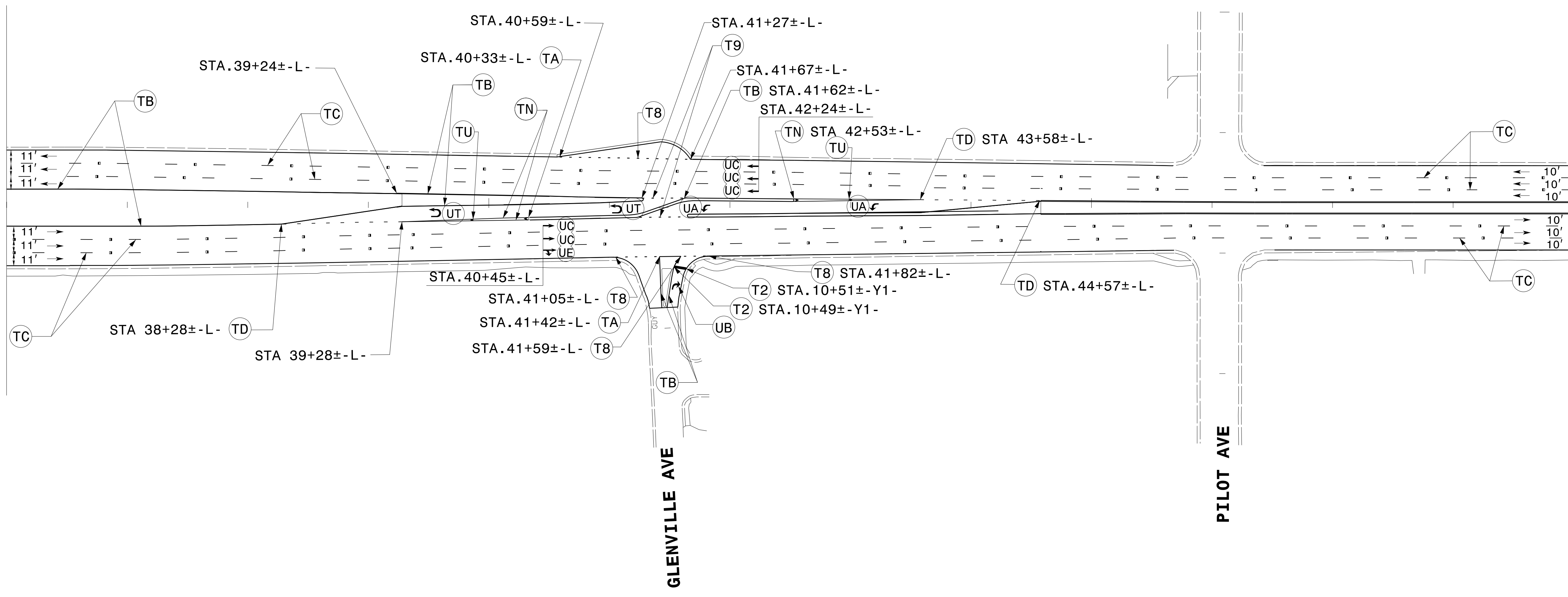

40

45

PILOT AVE

GLENVILLE AVE

SYSTEMS  
DESIGN  
CONSULTANTS

**PAVEMENT MARKING DETAIL**

PROJECT REFERENCE NO. W-5206AM	SHEET NO. PMP-6
APPROVED: <i>Steve Miller</i> 9/25/2015	
DATE: 9/25/2015	
SEAL	

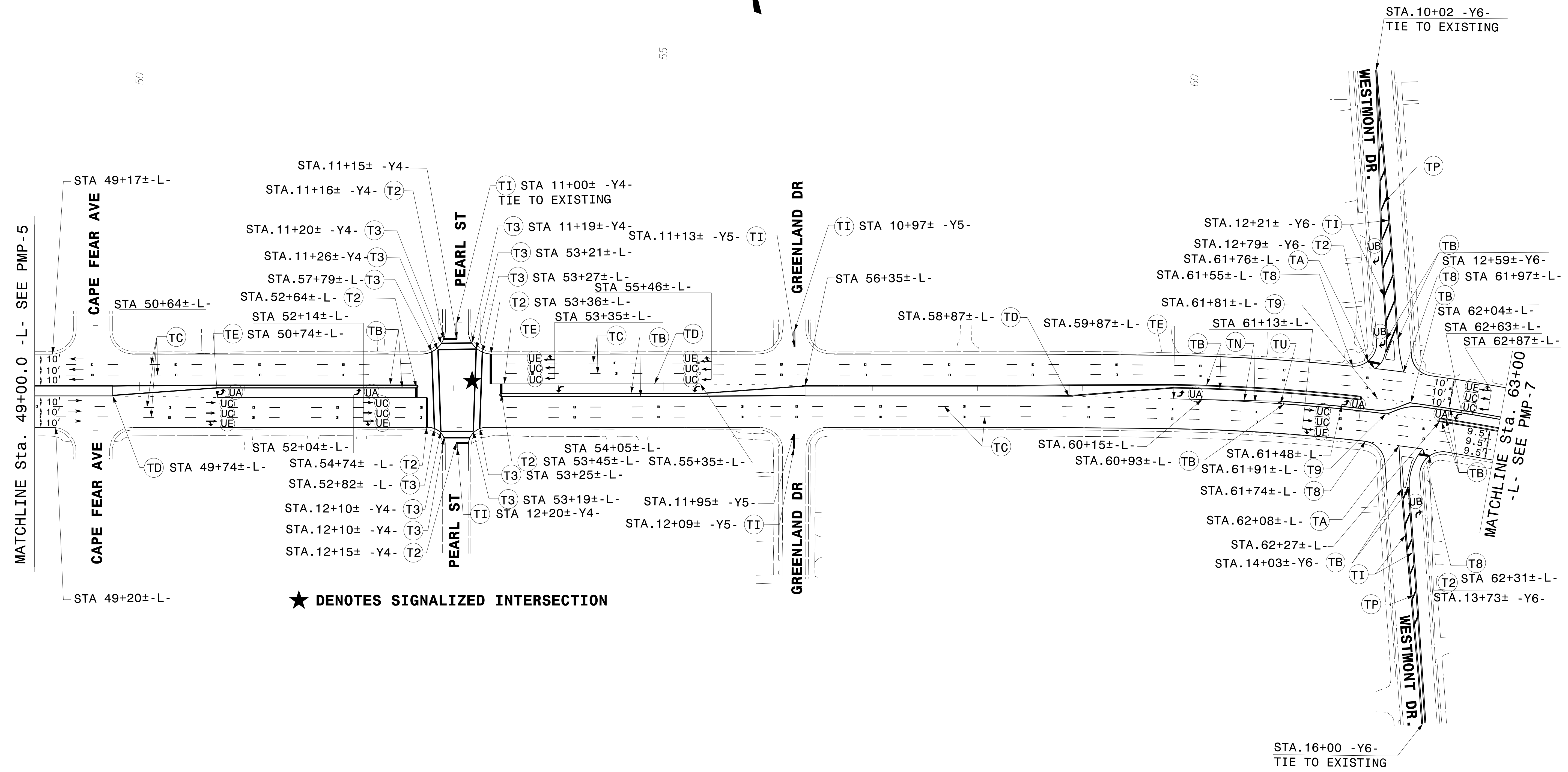
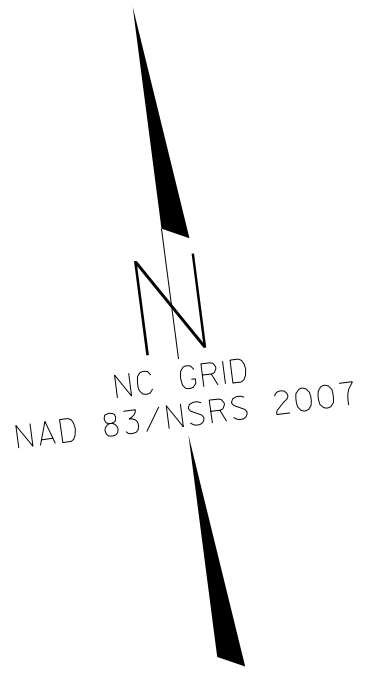

★ DENOTES SIGNALIZED INTERSECTION

**PAVEMENT MARKING DETAIL**

SYSTEMS TIME: 9/25/2015 10:00:00 AM  
 USER: SD MILLER  
 PROJECT: W-5206AM  
 SHEET: PMP-6



PROJECT REFERENCE NO. W-5206AM	SHEET NO. PMP-7
APPROVED: <i>Steve Miller</i> <small>REGISTERED PROFESSIONAL ENGINEER NO. 15000</small>	
DATE: 9/25/2015	

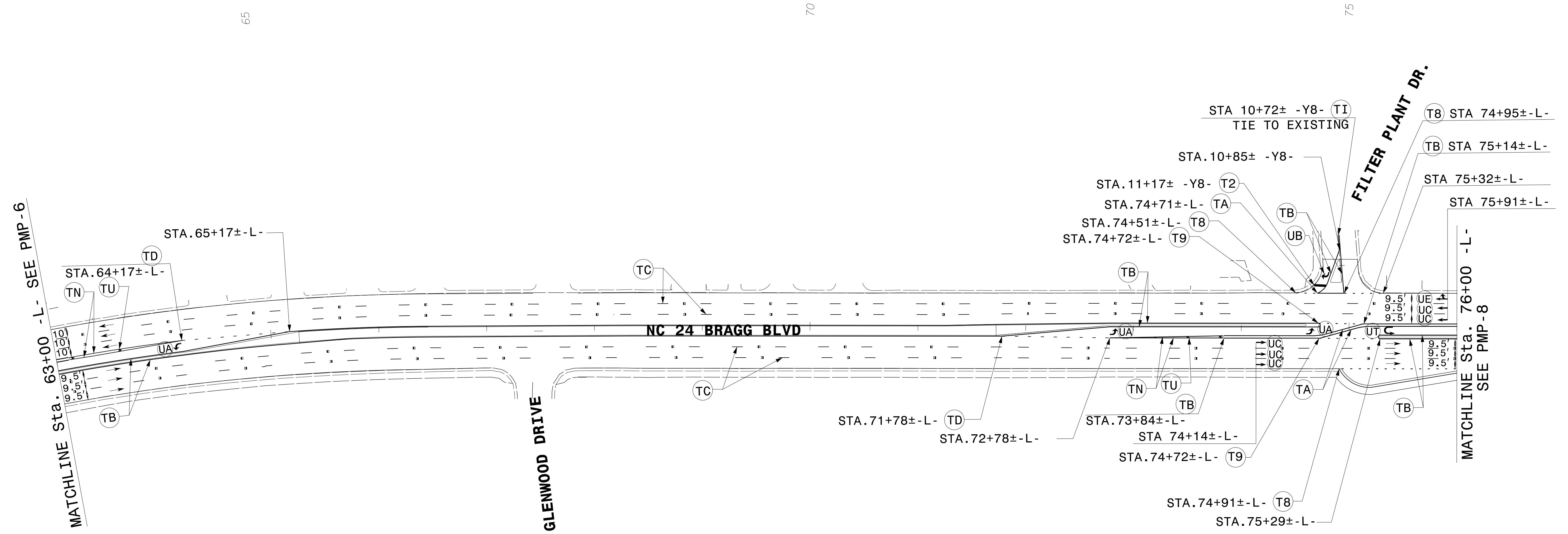
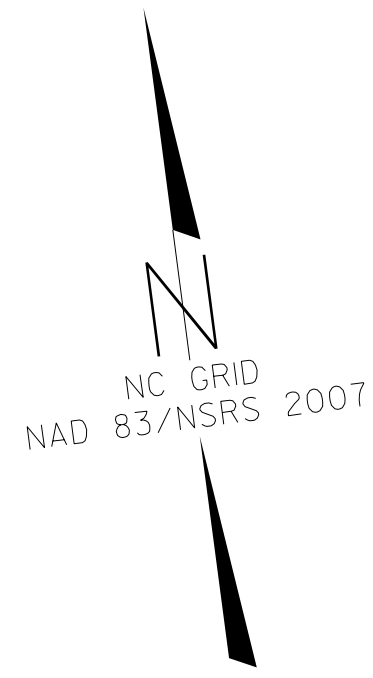
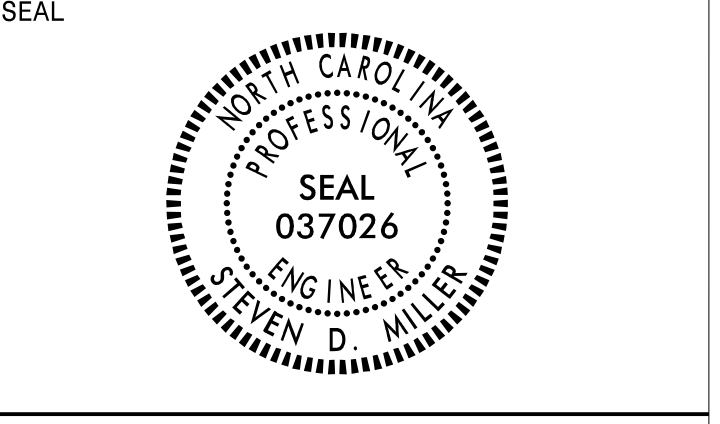

**PAVEMENT MARKING DETAIL**

SYSTEMS DESIGN CONSULTANTS



PROJECT REFERENCE NO. W-5206AM	SHEET NO. PMP-9
APPROVED: <i>Steve Miller</i> #806015CEE8486	
DATE: 9/25/2015	
SEAL	



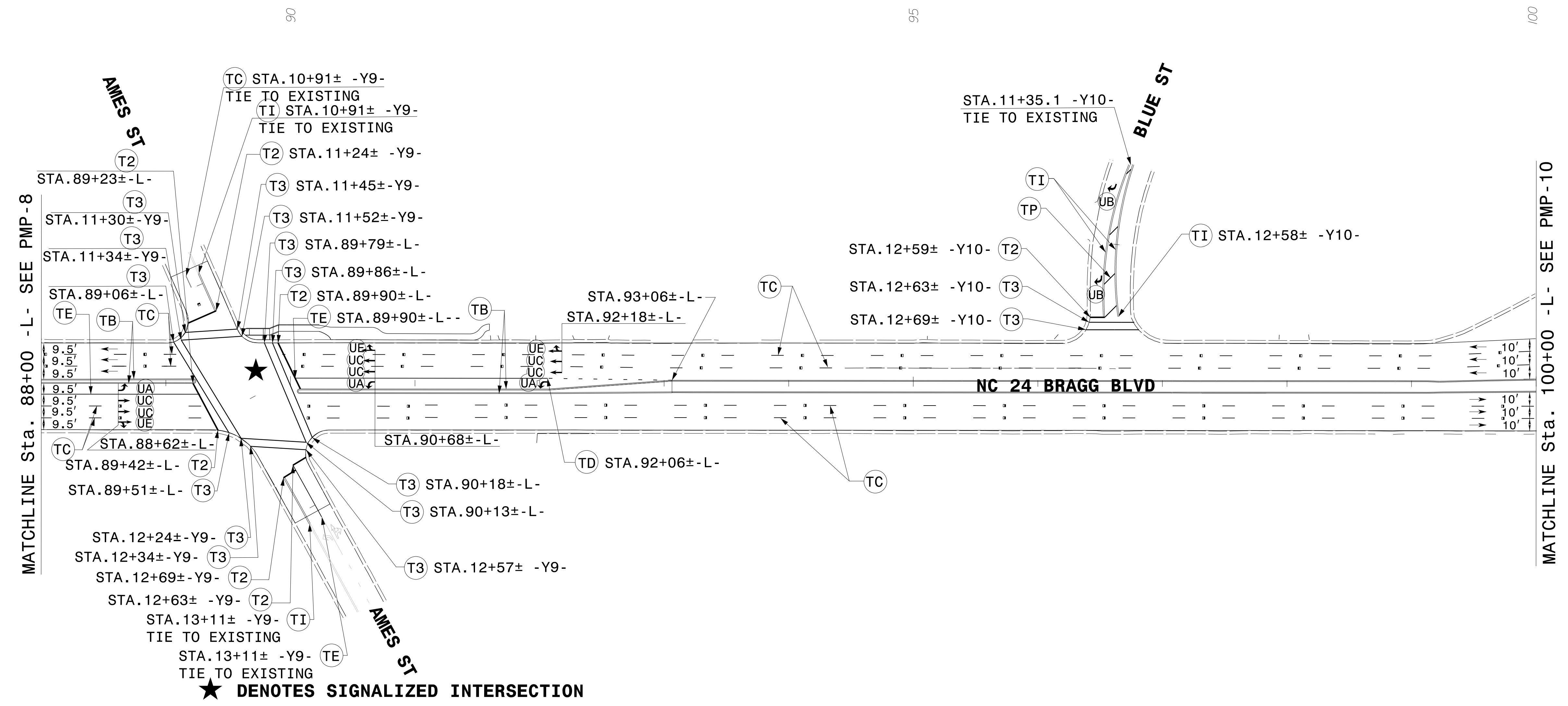
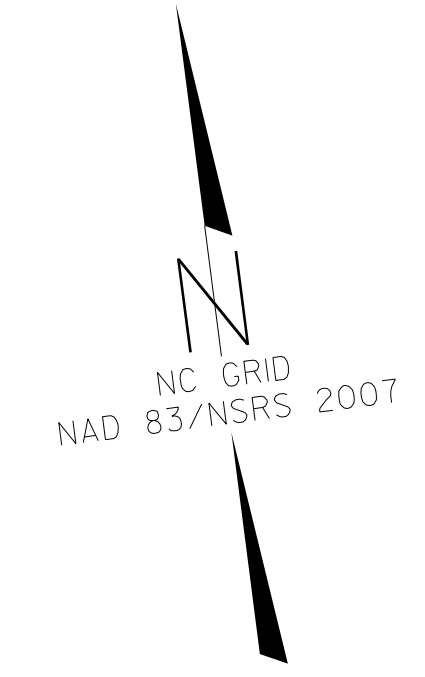

SYSTEMS DESIGN  
 CONSULTANTS  
 PAVEMENT MARKING

**PAVEMENT MARKING DETAIL**

PROJECT REFERENCE NO. W-5206AM	SHEET NO. PMP-10
APPROVED: <i>Steve Miller</i> <small>9/25/2015</small>	
DATE: 9/25/2015	
SEAL	

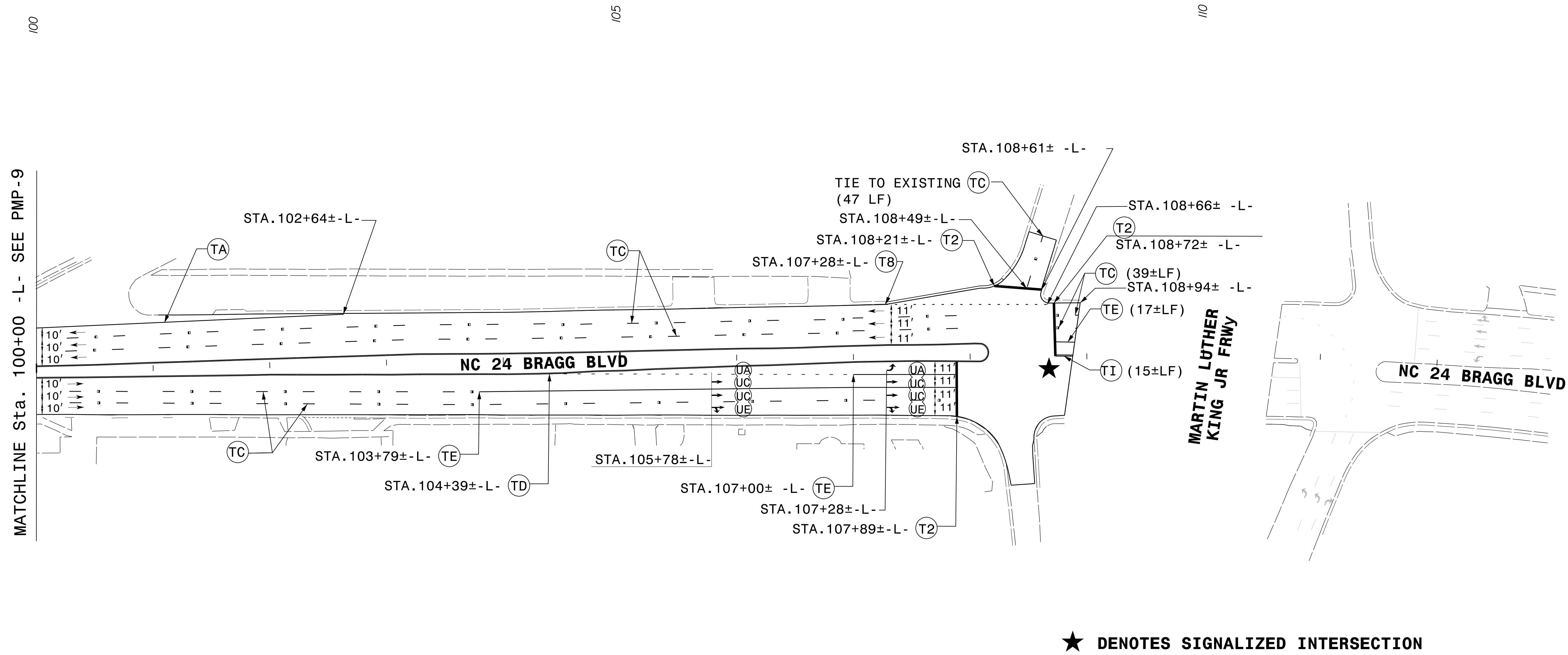
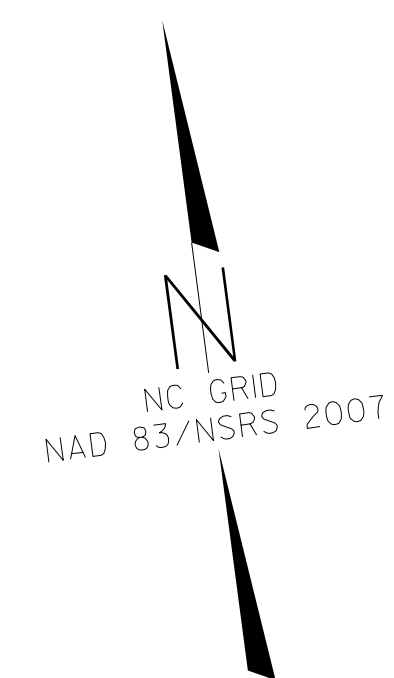

★ DENOTES SIGNALIZED INTERSECTION

PAVEMENT MARKING DETAIL

SYSTEMS DESIGN CONSULTANTS

PROJECT REFERENCE NO. W-5206AM	SHEET NO. PMP-II
APPROVED: <i>Steve Miller</i> 9/25/2015	
DATE: 9/25/2015	
SEAL	

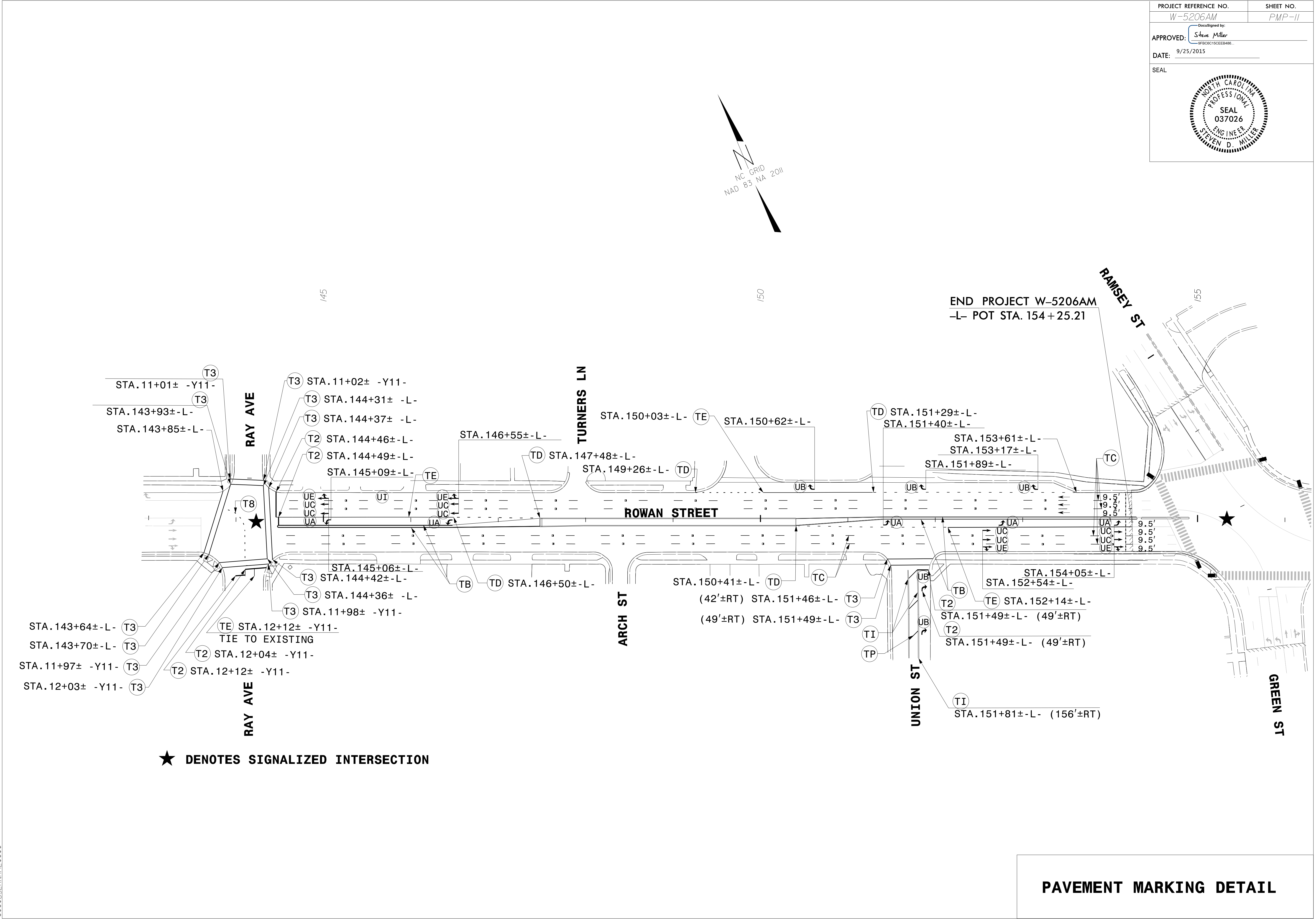
★ DENOTES SIGNALIZED INTERSECTION

**PAVEMENT MARKING DETAIL**

SYSTEMS DESIGN CONSULTANTS, INC.