

PLAN - STAGE II

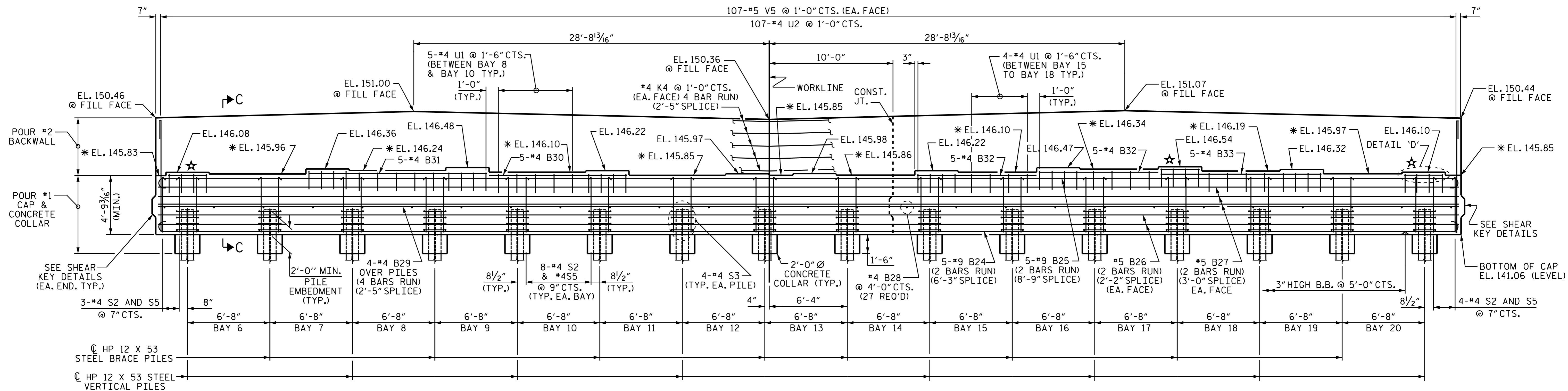

ELEVATION - STAGE II

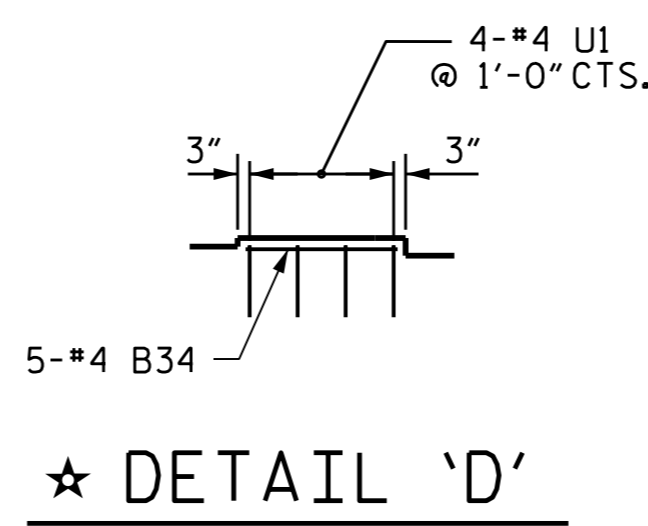
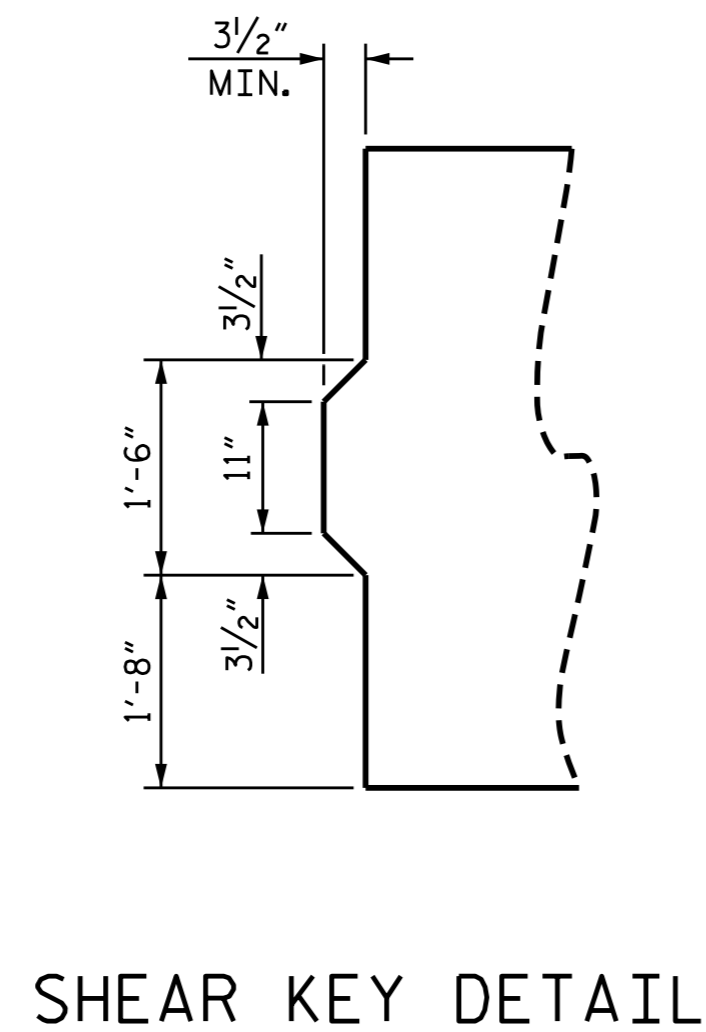

PROJECT NO. I-3318BB
JOHNSTON COUNTY
 STATION: 24+68.00 -L-

SHEET 3 OF 6

REVISIONS						SHEET NO.
NO.	BY:	DATE:	NO.	BY:	DATE:	S-63
1			3			TOTAL SHEETS
2			4			78

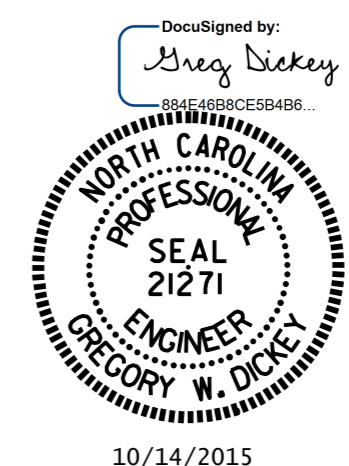

DRAWN BY: B.N.BARODAWALA DATE: 4-6-15
 CHECKED BY: DAVID GLADDEN DATE: 4-6-15
 DESIGN ENGINEER OF RECORD: ASHVIN PATEL DATE: 8-6-15