

NOTES

THE BARRIER RAIL IN A CONTINUOUS UNIT SHALL NOT BE CAST UNTIL ALL SLAB CONCRETE IN THE UNIT HAS BEEN CAST AND HAS REACHED A MINIMUM COMPRESSIVE STRENGTH OF 3,000 PSI.

ALL REINFORCING STEEL IN BARRIER RAILS SHALL BE EPOXY COATED.

GROOVED CONTRACTION JOINTS, 1/2" IN DEPTH, SHALL BE TOOLED IN ALL EXPOSED FACES OF THE BARRIER RAIL AND IN ACCORDANCE WITH ARTICLE 825-10(B) OF THE STANDARD SPECIFICATIONS, THE CONTRACTION JOINT SHALL BE LOCATED AT EACH THIRD POINT BETWEEN BARRIER RAIL EXPANSION JOINTS. ONLY ONE CONTRACTION JOINT IS REQUIRED AT MIDPOINT OF BARRIER RAIL SEGMENTS LESS THAN 20 FEET IN LENGTH AND NO CONTRACTION JOINTS ARE REQUIRED FOR THOSE SEGMENTS LESS THAN 10 FEET IN LENGTH.

FOR APPLICATION OF BRIDGE COATING, SEE SPECIAL PROVISIONS.

BAR TYPES

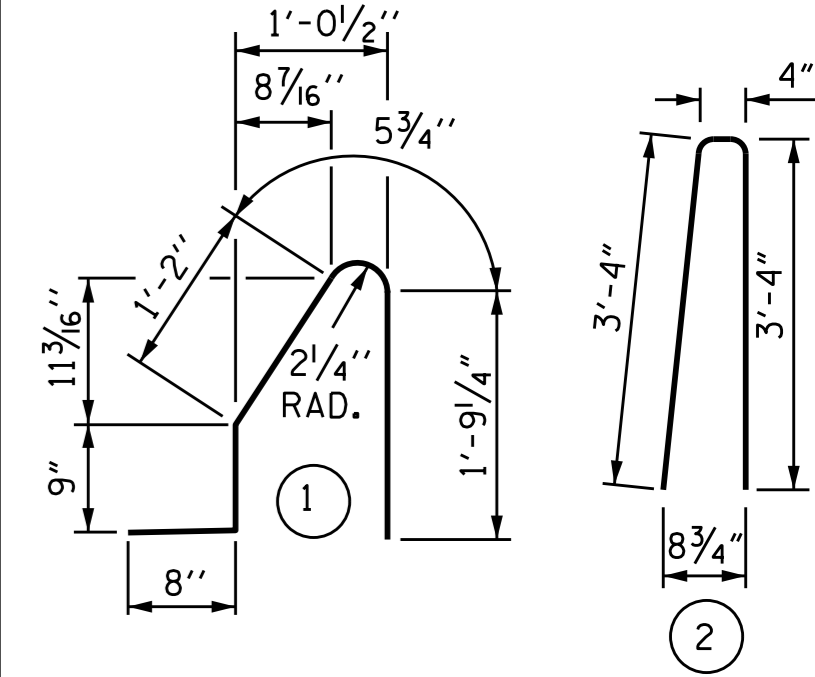

ALL BAR DIMENSIONS ARE OUT TO OUT

BILL OF MATERIAL

FOR CONCRETE BARRIER RAIL ONLY

BAR	NO.	SIZE	TYPE	LENGTH	WEIGHT
*B1	12	#5	STR	17'-10"	223
*B2	10	#5	STR	18'-3"	190
*B3	132	#5	STR	23'-7"	3247
*B4	44	#5	STR	21'-7"	991
*B5	44	#5	STR	22'-7"	1036
*B6	12	#5	STR	17'-8"	221
*B7	10	#5	STR	17'-4"	180
*S1	540	#5	1	4'-10"	2722
*S2	540	#5	2	7'-0"	3943

* EPOXY COATED REINFORCING STEEL 12753 LBS.

CLASS AA CONCRETE
 BRIDGE DECK 73.6 CU. YDS.
 APPROACH SLABS 5.6 CU. YDS.
 TOTAL 79.2 CU. YDS.

CONCRETE BARRIER RAIL
 BRIDGE DECK 541.29 LIN. FT.
 APPROACH SLABS 40.09 LIN. FT.
 TOTAL 582.19 LIN. FT.

SEE SHEET 1 OF 2
 FOR PLAN OF BARRIER RAIL

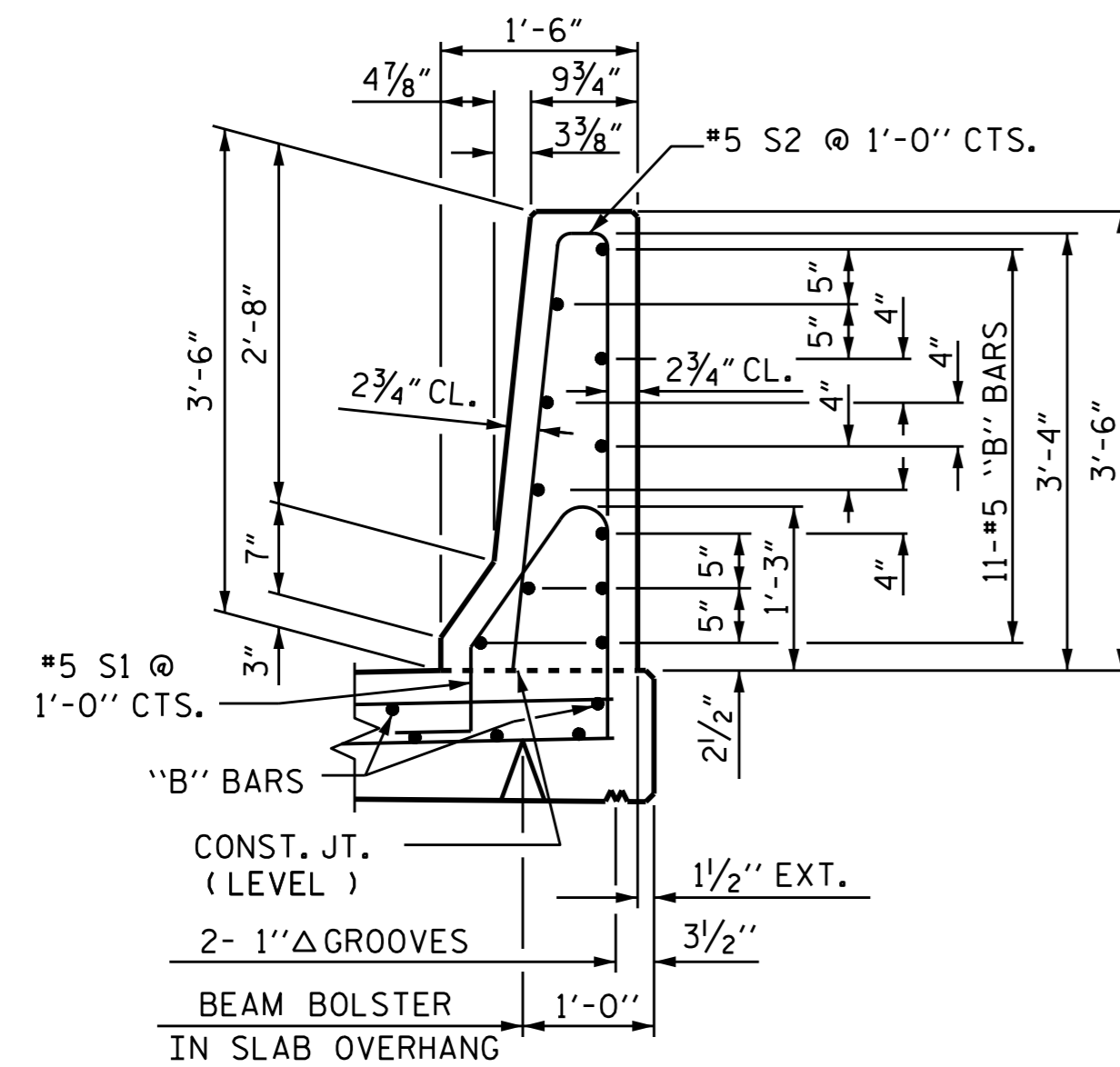

SECTION THRU RAIL

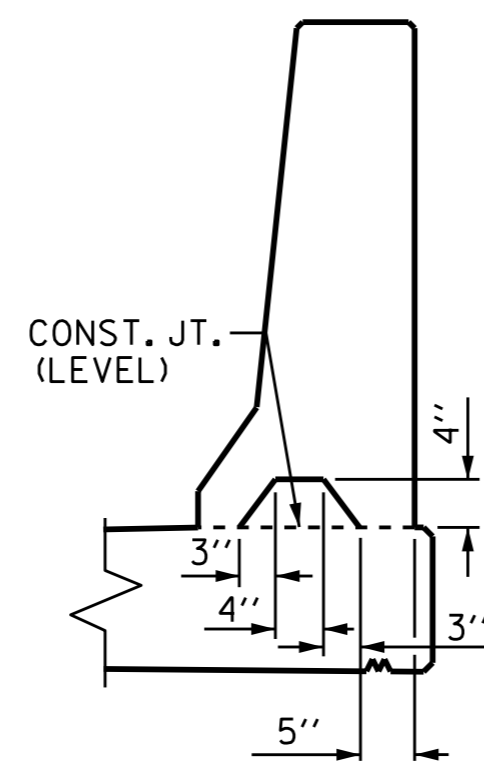

SECTION S-S
 AT DAM IN OPEN JOINT
 (THIS IS TO BE USED ONLY
 WHEN SLIP FORM IS USED)

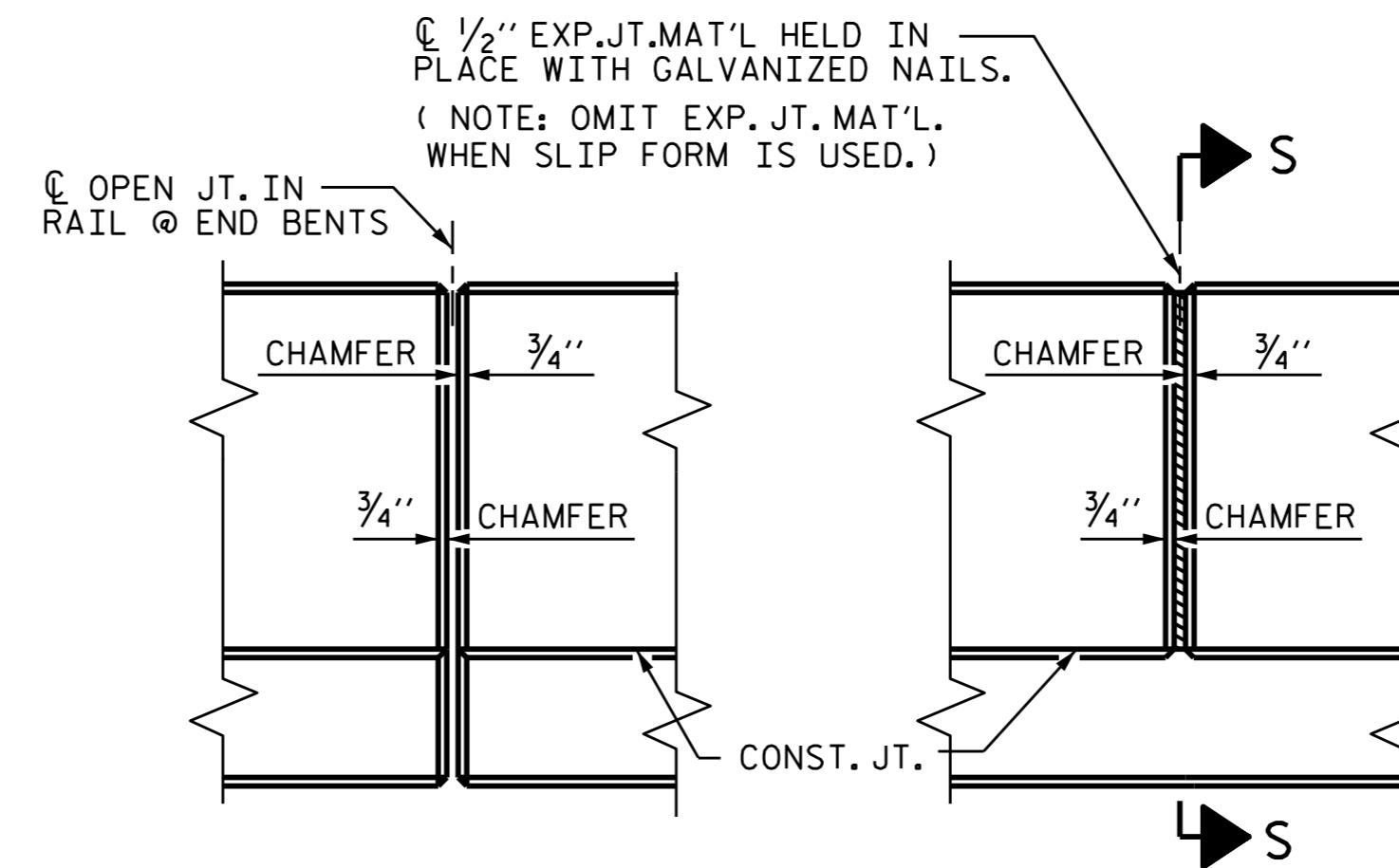

ELEVATION AT EXPANSION JOINTS
BARRIER RAIL DETAILS

PROJECT NO. I-3318BB
JOHNSTON COUNTY
 STATION: 24+68.00 -L-

SHEET 2 OF 2

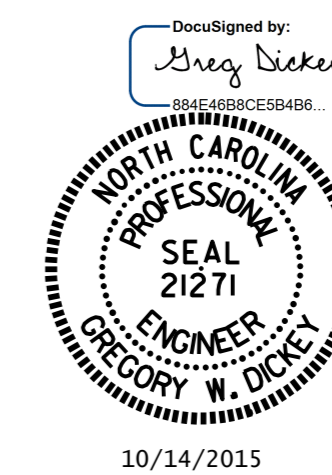

STATE OF NORTH CAROLINA
 DEPARTMENT OF TRANSPORTATION
 RALEIGH
 STANDARD
 CONCRETE
 BARRIER RAIL

ASSEMBLED BY :	D. G. ELY	DATE :	10/2015
CHECKED BY :	G. W. DICKEY	DATE :	10/2015
DRAWN BY :	ARB 5/87	REV. 10/1/11	MAA/GM
CHECKED BY :	SJD 9/87	REV. 7/12	MAA/GM
		REV. 6/13	MAA/GM

REVISIONS						SHEET NO. S-35
NO.	BY:	DATE:	NO.	BY:	DATE:	
1			3			TOTAL SHEETS 78
2			4			