

STATE OF  
 NORTH CAROLINA  
 DEPT. OF TRANSPORTATION  
 DIVISION OF HIGHWAYS  
 RALEIGH, N.C.

ENGLISH DETAIL DRAWING FOR  
**CONCRETE STEPS WITH HANDRAIL**

SHEET 1 OF 1  
**844D01**

**GENERAL NOTES :**

- 1- CONSTRUCT PROPOSED STEEL PIPE RAIL OF 1½" DIAMETER SCHEDULE 40 PLAIN END GALVANIZED STEEL PIPE MEETING THE REQUIREMENTS OF ASTM A53. EMBED PIPE RAIL 8" INTO PROPOSED STEPS WITH CHEMICAL OR CONCRETE GROUT ANCHORING SYSTEM AS DIRECTED BY THE ENGINEER.
- 2- USE A ROTARY DRILL FOR DRILLING THE HOLES FOR THE PIPE RAIL. NO IMPACT DRILLS ALLOWED.
- 3- USE CLASS "B" CONCRETE THROUGHOUT FOR CONCRETE STEPS.
- 4- LOCATION AND QUANTITIES SHOWN ARE APPROXIMATE ONLY. EXACT LOCATION AND QUANTITIES WILL BE DETERMINED BY THE ENGINEER.
- 5- ALL WORK AS DIRECTED BY THE ENGINEER.
- 6- REPAIR OF GALVANIZING IN ACCORDANCE WITH SCT.1076 OF THE STANDARD SPECIFICATIONS.
- 7- WELD IN ACCORDANCE WITH ARTICLE 1072-18 OF THE STANDARD SPECIFICATIONS.
- 8- 2" CLEAR SPACING ON ALL REINFORCING BARS.
- 9- EXTEND HORIZONTAL REINFORCING BARS UPWARD INTO SIDE WALLS.
- 10- ALL HANDRAILS AND STEPS MUST COMPLY WITH ADA STANDARDS FOR ACCESSIBLE DESIGN.

**CUBIC YARDS IN STANDARD CONCRETE STEPS**

| NO. OF STEPS              | 4' WIDE | 5' WIDE | 6' WIDE | 7' WIDE | ADDITIONAL CU. YDS. PER 1' WIDTH |
|---------------------------|---------|---------|---------|---------|----------------------------------|
| 2                         | 0.4     | 0.5     | 0.5     | 0.6     | 0.1                              |
| 3                         | 0.6     | 0.7     | 0.8     | 0.9     | 0.1                              |
| 4                         | 0.8     | 0.9     | 1.0     | 1.2     | 0.1                              |
| 5                         | 1.0     | 1.2     | 1.3     | 1.4     | 0.1                              |
| 6                         | 1.2     | 1.4     | 1.5     | 1.7     | 0.2                              |
| 7                         | 1.4     | 1.6     | 1.8     | 2.0     | 0.2                              |
| 8                         | 1.6     | 1.8     | 2.0     | 2.3     | 0.2                              |
| 9                         | 1.8     | 2.0     | 2.3     | 2.6     | 0.3                              |
| 10                        | 2.0     | 2.3     | 2.5     | 2.8     | 0.3                              |
| ADDITIONAL STEP INCREMENT | 0.2     | 0.2     | 0.2     | 0.3     | 0.1                              |

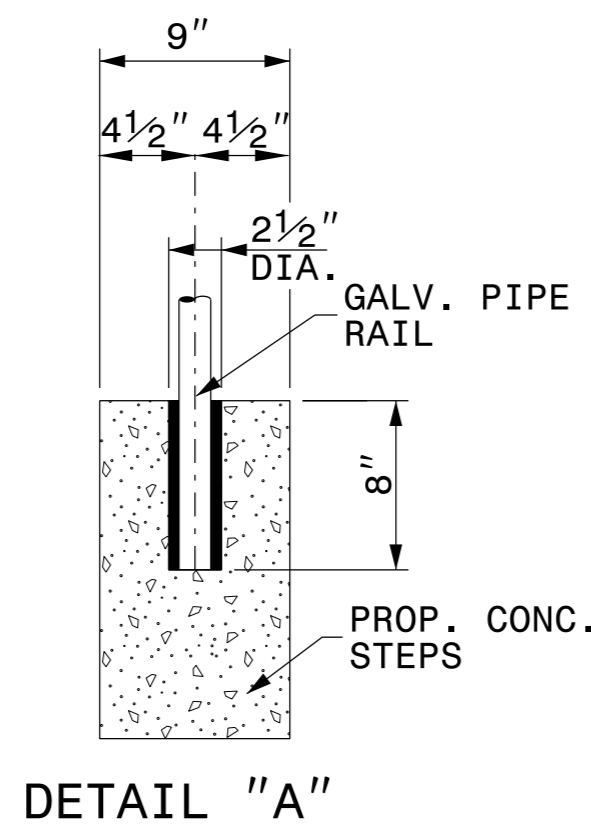

**DETAIL "A"**

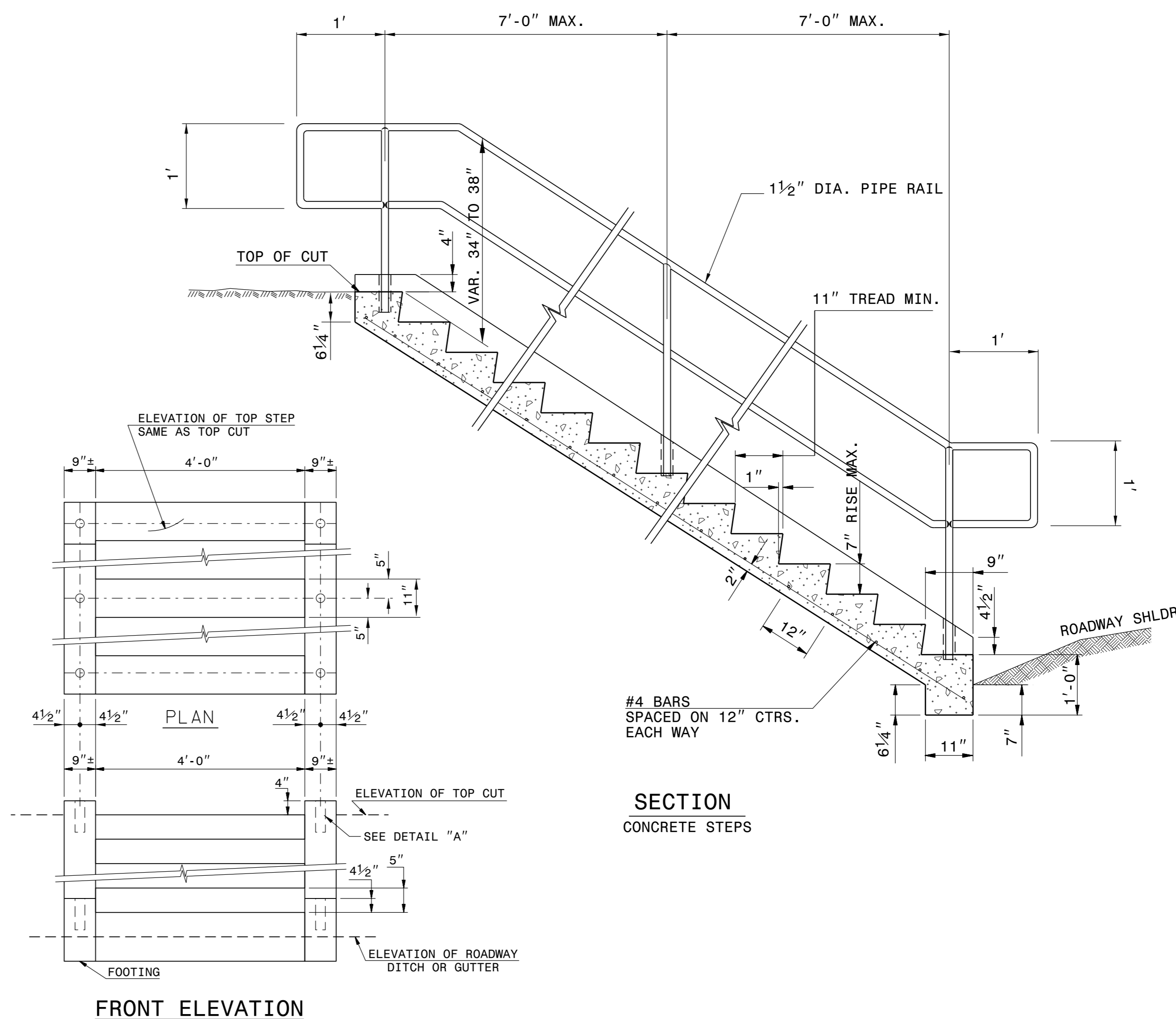

**SECTION  
CONCRETE STEPS**

STATE OF  
 NORTH CAROLINA  
 DEPT. OF TRANSPORTATION  
 DIVISION OF HIGHWAYS  
 RALEIGH, N.C.

ENGLISH DETAIL DRAWING FOR  
**CONCRETE STEPS WITH HANDRAIL**

SHEET 1 OF 1  
**844D01**

8/14/2015

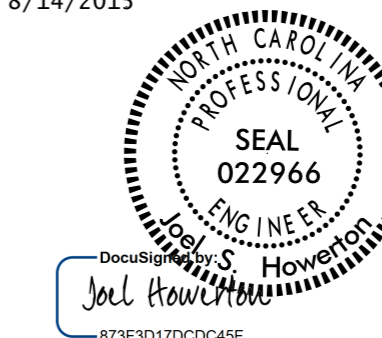

**CONTRACT STANDARDS AND DEVELOPMENT UNIT**  
 Office 919-707-6950 FAX 919-250-4119

**SEE PLATE FOR TITLE**

ORIGINAL BY: T.Spell DATE: Oct.7,1998  
 MODIFIED BY: DATE:  
 CHECKED BY: DATE:  
 FILE SPEC.: s:\usr\details\stand\844d01e.dgn

**DOCUMENT NOT CONSIDERED FINAL  
UNLESS ALL SIGNATURES COMPLETED**

844D01.dgn  
 8/14/2015 10:00:00 AM  
 J. S. Howerton  
 873F3D17DCC46F