

FRONT VIEW

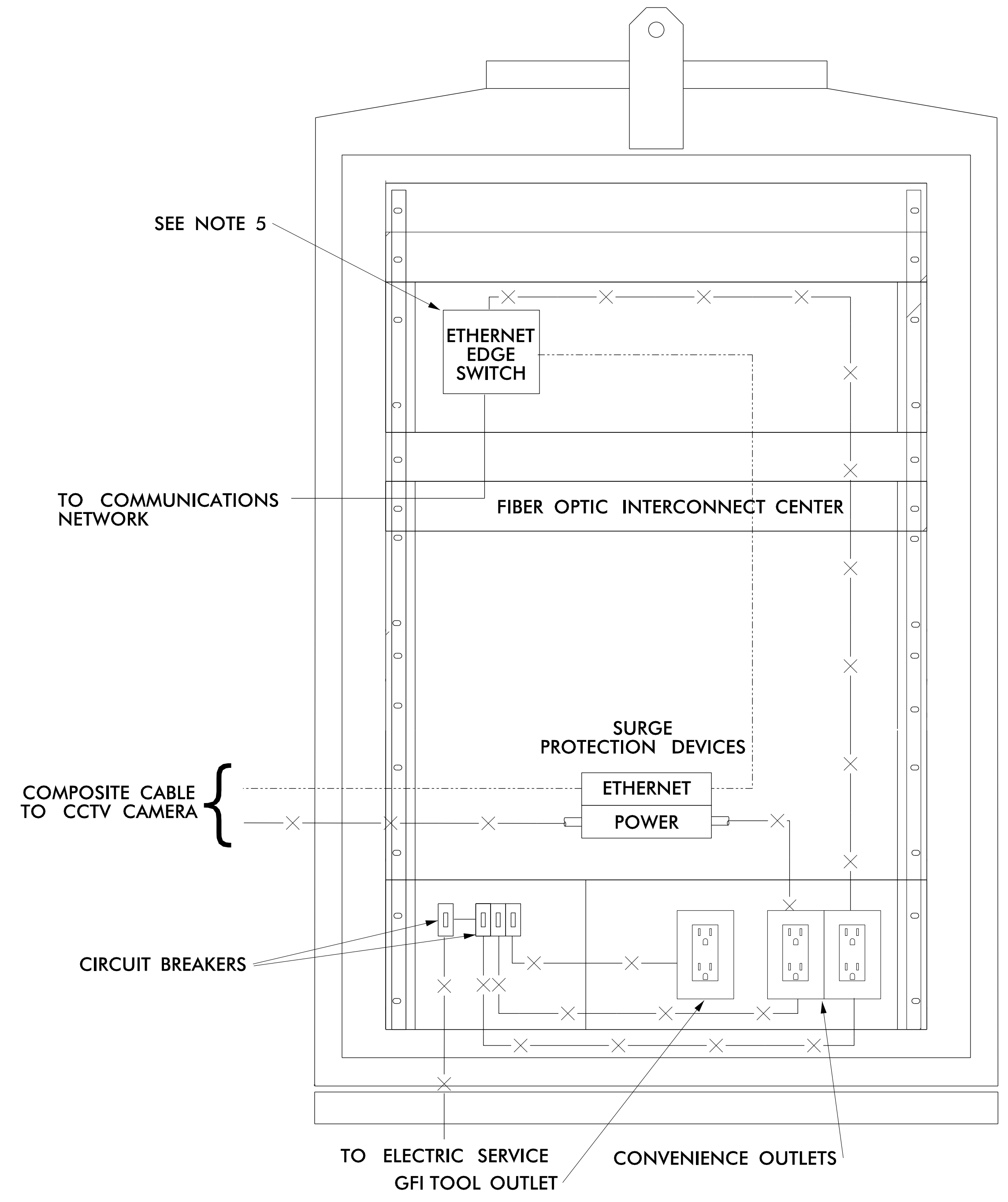

CABINET WIRING VIEW

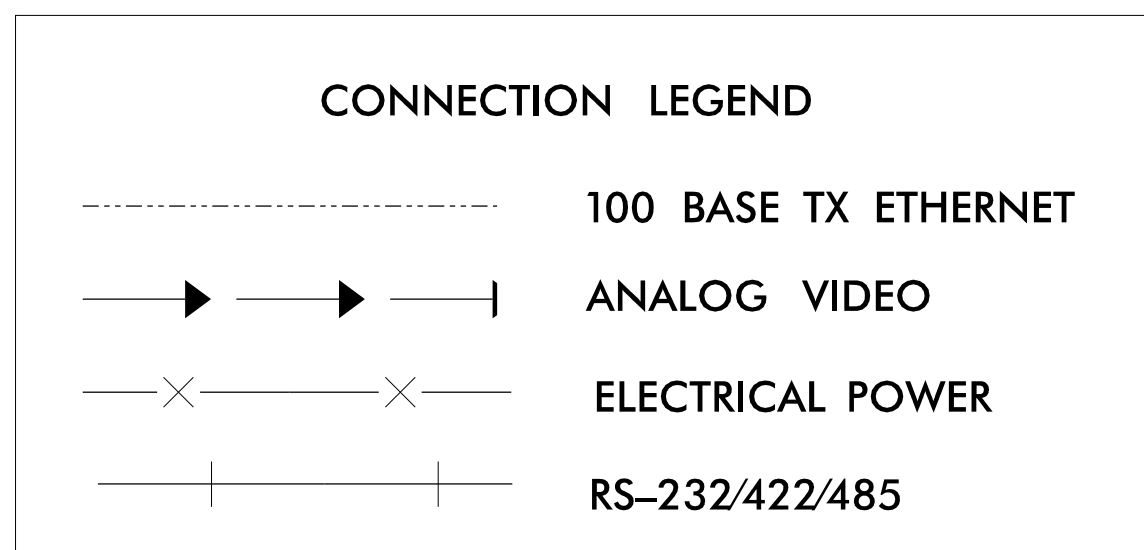

NOTES

- ALL DIMENSIONS AND SCALE ARE APPROXIMATE.
- CABINETS WILL BE CALTRANS TYPE 336A
- CONDUIT ENTRANCES SHALL BE IN BOTTOM OF CABINET.
- THERE WILL BE FRONT AND REAR DOORS. BOTH DOORS SHALL HAVE THE HINGE-SIDE NEXT TO THE POLE WHEN POLE MOUNTED.
- INSTALL ETHERNET EDGE SWITCH WHEN SHOWN IN PLANS.

04-JUN-2015 16:49
 T:\Product\ITSS\NC001\100037777 - High Point Sig Sys\Special Detail\ITS-5.03.dgn
 SLOC3653 AT LUS291201

Prepared for the Offices of: 750 Greenfield Parkway, Garner, NC 27529	High Point Signal System CCTV Cabinet Assembly Layout		SEAL 019962 HENRY CAROLINA ENGINEER FRED BADGETT
	Division 7 Guilford County High Point	PLAN DATE: June 2015 REVIEWED BY: HA Badgett	
SCALE: NTS	REVISIONS:	INIT.:	DATE: 6/5/2015

CADD File name: ITS-5.03.dgn

ATKINS 1616 EAST MILLBROOK ROAD, SUITE 310
 RALEIGH, NORTH CAROLINA 27609
 (919) 876-6888 NCBEES #F-0326