

PHASING DIAGRAM

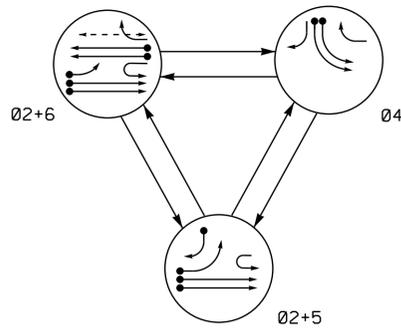

SIGNAL FACE	PHASE			
	02+5	02+6	04	F
21, 22	G	G	R	Y
41	R	R	G	R
42	R	R	G	R
51	←	←	←	←
61	←	←	←	←
62	R	G	R	Y
63	R	G	R	Y
P61, P62	DW	W	DW	DRK

PHASING DIAGRAM DETECTION LEGEND

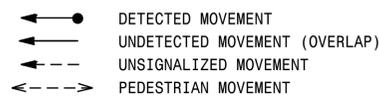

SIGNAL FACE I.D.

All Heads L.E.D.

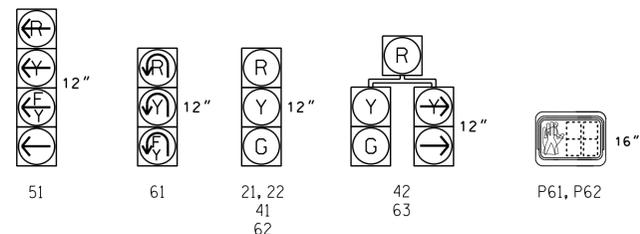

OASIS 2070 LOOP & DETECTOR INSTALLATION CHART												
INDUCTIVE LOOPS					DETECTOR PROGRAMMING							
LOOP	SIZE (FT)	DISTANCE FROM STOPBAR (FT)	TURNS	NEW LOOP	PHASE	CALLING	EXTENSION	FULL TIME DELAY	STRETCH TIME	DELAY TIME	SYSTEM LOOP	NEW CARD
2A	6X6	300	EXIST	-	2	Y	Y	-	-	-	-	Y
2B	6X6	300	EXIST	-	2	Y	Y	-	-	-	-	Y
4A	6X60	0	2-4-2	-	4	Y	Y	-	-	-	-	Y
4B	6X60	0	2-4-2	-	4	Y	Y	-	-	-	-	Y
5A	6X60	0	2-4-2	-	5	Y	Y	-	-	15	-	Y
5B	6X60	0	2-4-2	-	5	Y	Y	-	-	20	-	Y
6A	6X6	300	EXIST	-	6	Y	Y	-	-	-	-	Y
6B	6X6	300	EXIST	-	6	Y	Y	-	-	-	-	Y

3 Phase Fully Actuated (High Point Signal System)

NOTES

- Refer to "Roadway Standard Drawings NCDOT" dated January 2012 and "Standard Specifications for Roads and Structures" dated January 2012.
- Do not program signal for late night flashing operation unless otherwise directed by the Engineer.
- Phase 5 may be lagged.
- Set all detector units to presence mode.
- In the event of loop replacement, refer to the current ITS and Signals Design Manual and submit a Plan of Record to the Signal Design Section.
- Locate new cabinet so as not to obstruct sight distance of vehicles turning right on red.
- Omit "WALK" and flashing "DON'T WALK" with no pedestrian calls.
- Program pedestrian heads to countdown the flashing "Don't Walk" time only.
- Existing lane control signs (R3-5L and/or R3-5R) may be removed at the direction of the Engineer.
- Pavement markings are existing.
- Maximum times shown in timing chart are for free-run operation only. Coordinated signal system timing values supersede these values.

OASIS 2070 TIMING CHART				
FEATURE	PHASE			
	2	4	5	6
Min Green 1 *	12	7	7	12
Extension 1 *	6.0	1.0	1.0	6.0
Max Green 1 *	100	25	15	100
Yellow Clearance	4.6	3.0	3.0	4.6
Red Clearance	1.9	3.3	2.4	1.9
Red Revert	2.0	2.0	2.0	2.0
Walk 1 *	-	-	-	7
Don't Walk 1	-	-	-	28
Seconds Per Actuation *	1.5	-	-	1.5
Max Variable Initial *	34	-	-	34
Time Before Reduction *	15	-	-	15
Time To Reduce *	45	-	-	45
Minimum Gap	3.0	-	-	3.0
Recall Mode**	SOFT RECALL	-	-	SOFT RECALL
Vehicle Call Memory	YELLOW	-	-	YELLOW
Dual Entry	-	-	-	-
Simultaneous Gap	ON	ON	ON	ON

* These values may be field adjusted. Do not adjust Min Green and Extension times for phases 2 and 6 lower than what is shown. Min Green for all other phases should not be lower than 4 seconds.
 ** May be changed to Min Recall by Time of Day at discretion of City Traffic Engineer.

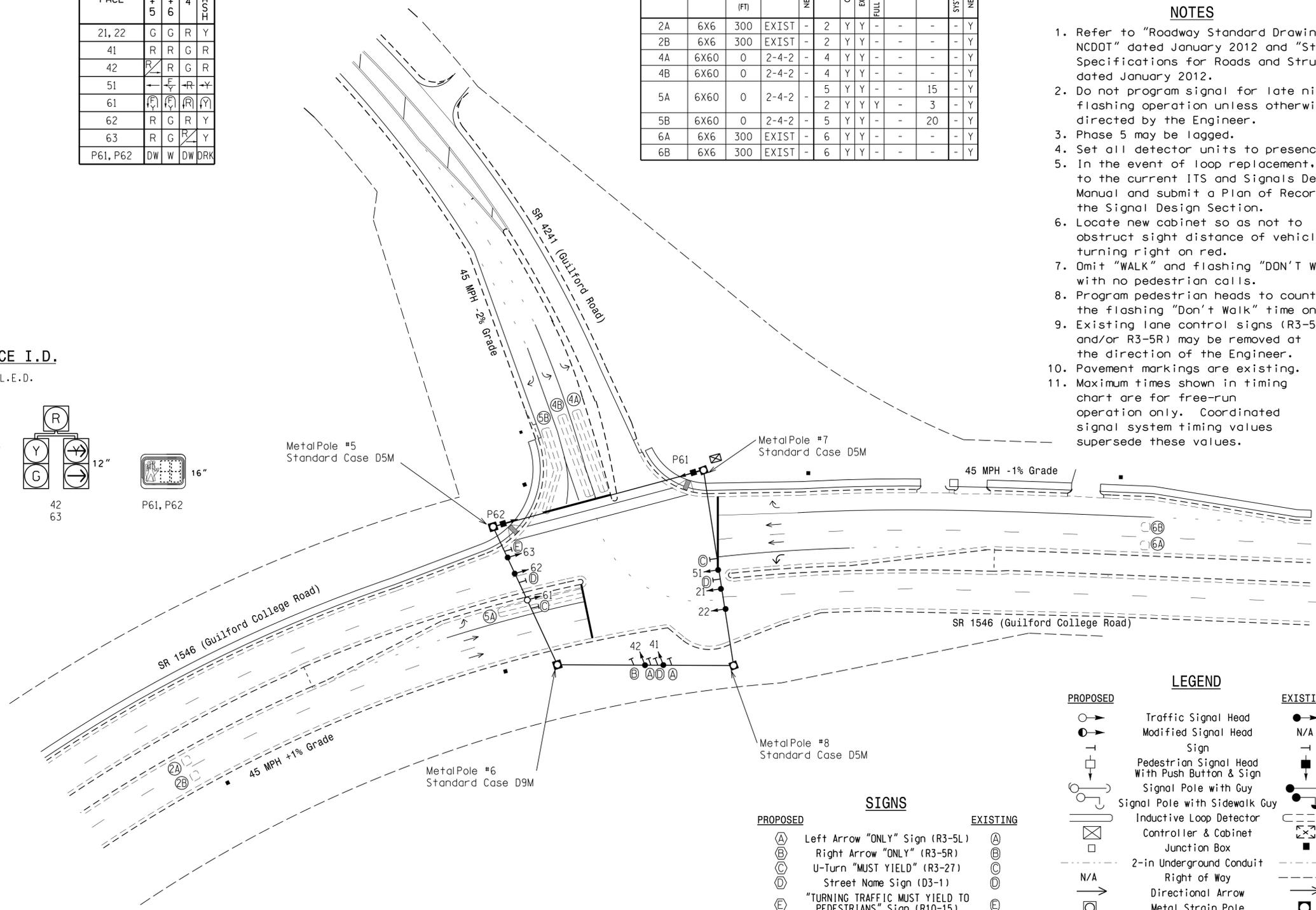

LEGEND

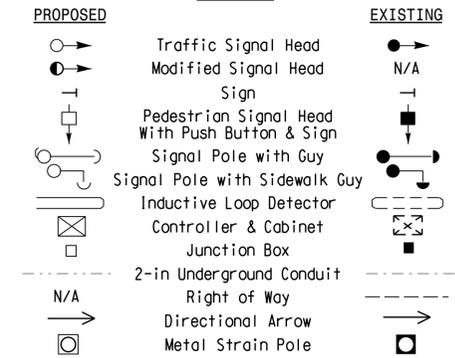

SIGNS

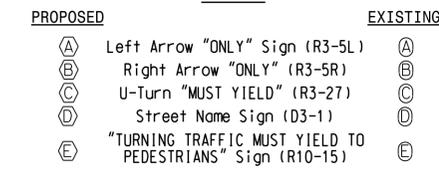

Signal Upgrade

Prepared In the Offices of:
 TRANSPORTATION MOBILITY AND SAFETY DIVISION
 NORTH CAROLINA DEPARTMENT OF TRANSPORTATION
 Signal Design Section
 750 N. Greenfield Pkwy, Garner, NC 27529

SR 1546 (Guilford College Rd.) at SR 4241 (Guilford Road)

Division 7 Guilford County Jamestown

PLAN DATE: May 2014 PREPARED BY: T. L. Averette REVIEWED BY:

REVISIONS: INIT. DATE

SCALE: 0 40 1"=40'

SEAL: NORTH CAROLINA PROFESSIONAL ENGINEER ROBERT J. ZIEMBA 026486 3/16/2015

SIG. INVENTORY NO. 07-2031

16-MAR-2015 14:59
 S:\MITSU\ITS\SIGNAL\Central\Region04\iv_74c-5558_High_Point\Signal_Plans\07-2031-4072031_s1a.dsn_20150316.dgn
 rz1:erba