

EDI MODEL 2018ECLip-NC CONFLICT MONITOR PROGRAMMING DETAIL
(remove jumpers and set switches as shown)

REMOVE DIODE JUMPERS 1-5, 1-6, 1-9, 1-11, 2-5, 2-6, 2-9, 2-11, 4-8, 5-9, 5-11, 6-9, 6-11 AND 9-11.

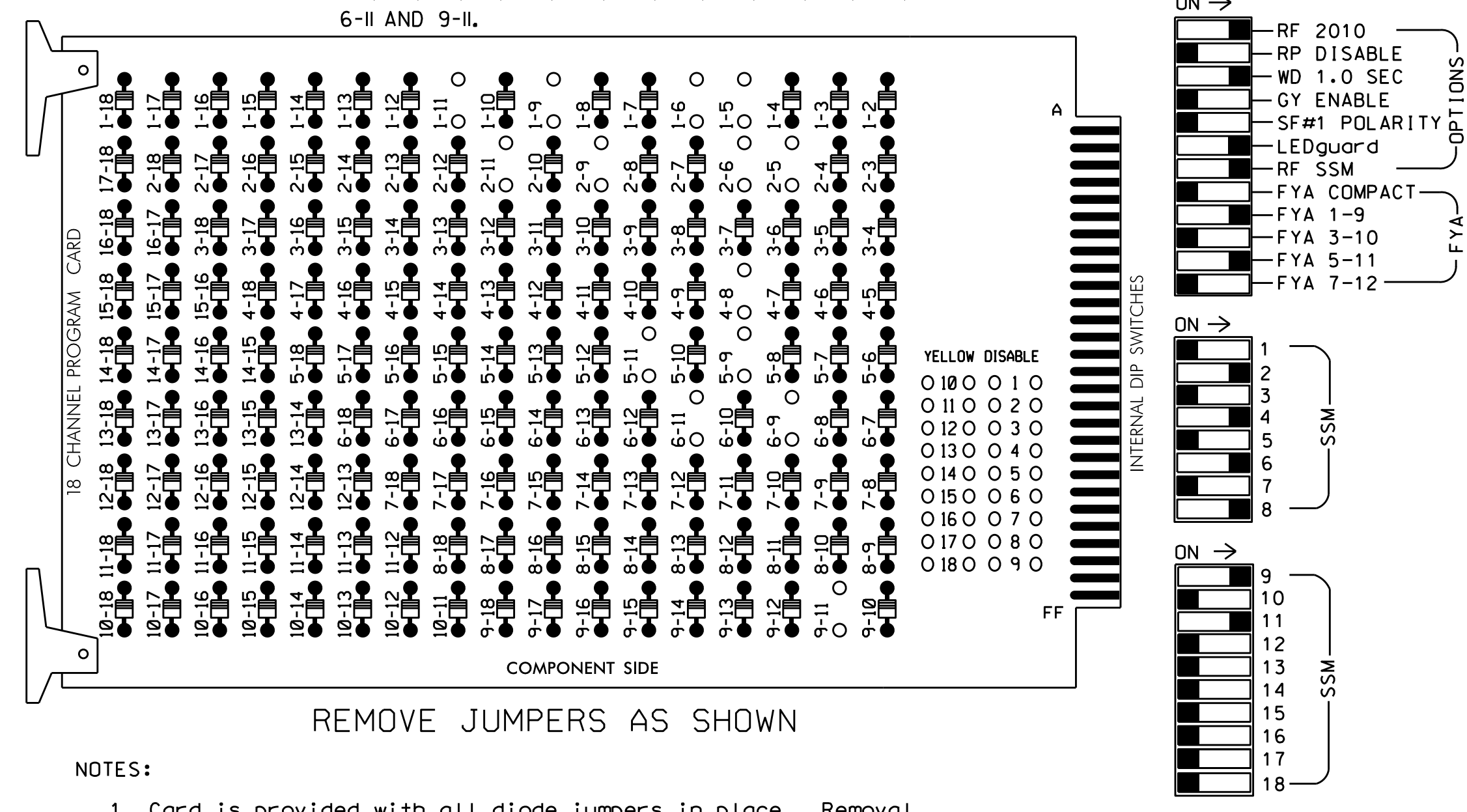

- NOTES:
- Card is provided with all diode jumpers in place. Removal of any jumper allows its channels to run concurrently.
 - Ensure jumpers SEL2-SEL5 and SEL9 are present on the monitor board.
 - Ensure that Red Enable is active at all times during normal operation.
 - Integrate monitor with Ethernet network in cabinet.

- NOTES**
- To prevent "flash-conflict" problems, insert red flash program blocks for all unused vehicle load switches in the output file. The installer shall verify that signal heads flash in accordance with the Signal Plans.
 - Program phases 4 and 8 for Dual Entry.
 - Enable Simultaneous Gap-Out for all phases.
 - Program phases 2 and 6 for Variable Initial and Gap Reduction.
 - Program phases 2 and 6 for Start Up In Green.
 - Program phases 2 and 6 for Yellow Flash, and overlap 1 as Wag Overlaps.
 - The cabinet and controller are part of the High Point Signal System.

EQUIPMENT INFORMATION

CONTROLLER.....2070L
 CABINET.....332 /W/ AUX
 SOFTWARE.....ECONOLITE OASIS
 CABINET MOUNT.....BASE
 OUTPUT FILE POSITIONS...18 WITH AUX. OUTPUT FILE
 LOAD SWITCHES USED.....S1,S2,S5,S7,S8,S11,AUX S1,AUX S4.
 PHASES USED.....1,2,4,5,6,8.
 OVERLAP "A".....1+2
 OVERLAP "B".....NOT USED
 OVERLAP "C".....5+6
 OVERLAP "D".....NOT USED

SIGNAL HEAD HOOK-UP CHART

LOAD SWITCH NO.	S1	S2	S3	S4	S5	S6	S7	S8	S9	S10	S11	S12	AUX S1	AUX S2	AUX S3	AUX S4	AUX S5	AUX S6
CMU CHANNEL NO.	1	2	13	3	4	14	5	6	15	7	8	16	9	10	17	11	12	18
PHASE	1	2	2 PED	3	4	4 PED	5	6	6 PED	7	8	8 PED	OLA	OLB	SPARE	OLC	OLD	SPARE
SIGNAL HEAD NO.	11	21,22,23	NU	NU	41,42	NU	51	61,62	NU	NU	81,82	NU	11	NU	NU	51	NU	NU
RED		128			101			134			107							
YELLOW	*	129			102		*	135			108							
GREEN		130			103			136			109							
RED ARROW													A121			A114		
YELLOW ARROW													A122			A115		
FLASHING YELLOW ARROW													A123			A116		
GREEN ARROW	127							133										

NU = Not Used
 * Denotes install load resistor. See load resistor installation detail this sheet.
 * See pictorial of head wiring in detail below.

INPUT FILE POSITION LAYOUT (front view)

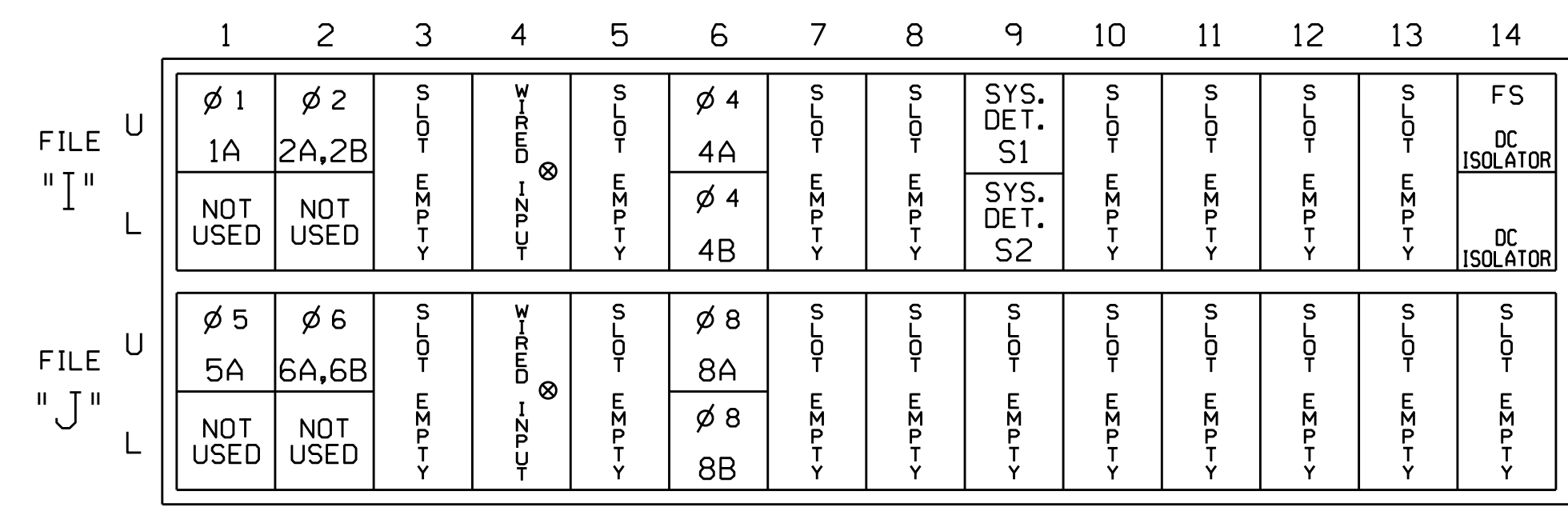

EX.: 1A, 2A, ETC. = LOOP NO.'S
 FS = FLASH SENSE
 ST = STOP TIME
 ⊗ Wired Input - Do not populate slot with detector card

INPUT FILE CONNECTION & PROGRAMMING CHART

LOOP NO.	LOOP TERMINAL	INPUT FILE POS.	PIN NO.	INPUT ASSIGNMENT NO.	DETECTOR NO.	NEMA PHASE	CALL	EXTEND	FULL TIME DELAY	STRETCH TIME	DELAY TIME
1A ¹	TB2-1,2	I1U	56	18	1	1	Y	Y			15
	-	J4U	48	10	26	6	Y	Y	Y		3
2A,2B	TB2-5,6	I2U	39	1	2	2	Y	Y			
4A	TB4-9,10	I6U	41	3	4	4	Y	Y			
4B	TB4-11,12	I6L	45	7	14	4	Y	Y			10
* S1	TB6-9,10	I9U	60	22	11	SYS					
* S2	TB6-11,12	I9L	62	24	13	SYS					
5A ²	TB3-1,2	J1U	55	17	5	5	Y	Y			15
	-	I4U	47	9	22	2	Y	Y	Y		3
6A,6B	TB3-5,6	J2U	40	2	6	6	Y	Y			
8A	TB5-9,10	J6U	42	4	8	8	Y	Y			
8B	TB5-11,12	J6L	46	8	18	8	Y	Y			10

- ¹Add jumper from I1-W to J4-W, on rear of input file.
²Add jumper from J1-W to I4-W, on rear of input file.

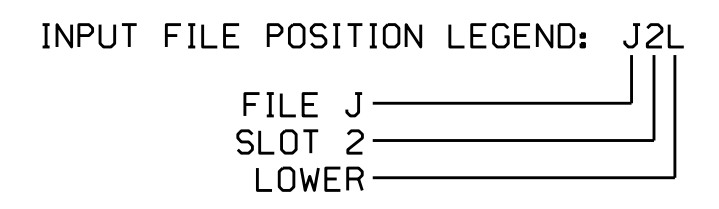

4 SECTION FYA PPLT SIGNAL WIRING DETAIL
(wire signal heads as shown)

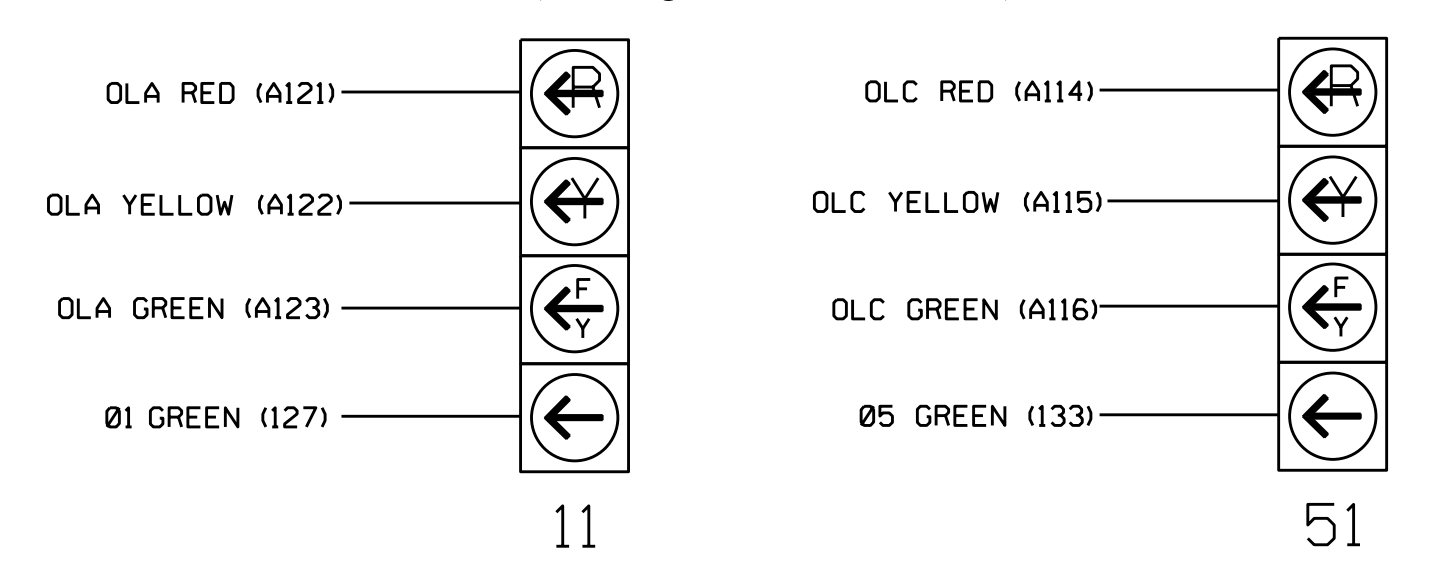

- NOTE**
- The sequence display for this signal requires special logic programming. See sheet 2 for programming instructions.

THIS ELECTRICAL DETAIL IS FOR THE SIGNAL DESIGN: 07-1745
 DESIGNED: April 2014
 SEALED: 3-31-15
 REVISED: N/A

LOAD RESISTOR INSTALLATION DETAIL
(install resistors as shown below)

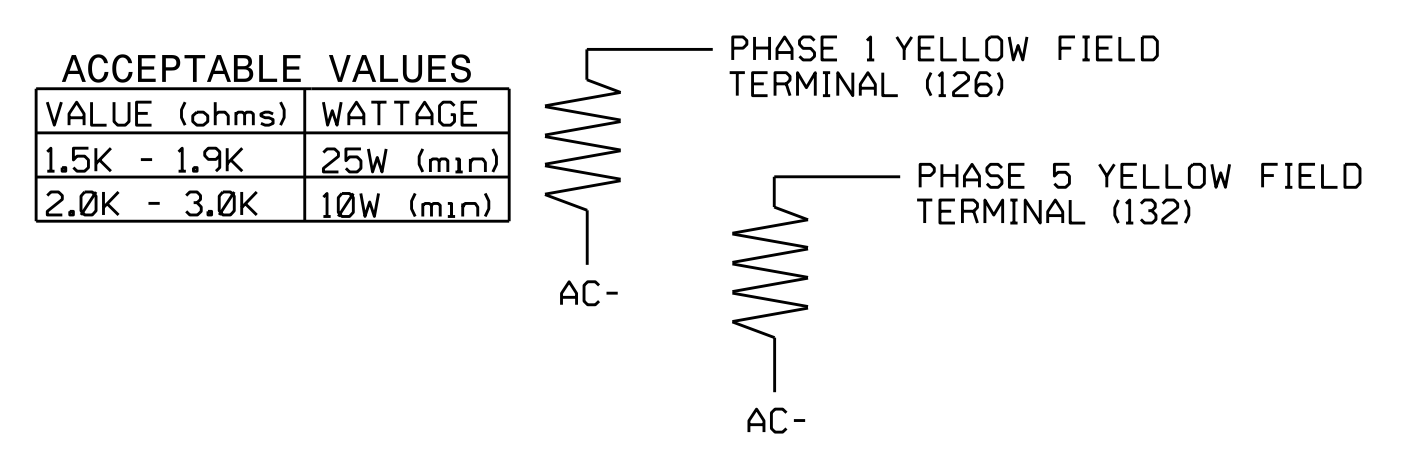

ELECTRICAL DETAIL SHEET 1 OF 2

Electrical and Programming Details For: SR 1896 (East Hartley Drive) at West Mall Lane and HPB Insurance Group

Division 7 Guilford County High Point

PLAN DATE: July 2014 REVIEWED BY: JTR

PREPARED BY: James Peterson REVIEWED BY:

750 N. Greenfield Pkwy, Garner, NC 27529

SEAL: JOHN T. ROWE, JR. ENGINEER

DocuSigned by: John T. Rowe, Jr. 4/15/2015

SIG. INVENTORY NO. 07-1745

15-APR-2015 07:39 S:\TSS\15-1\Sigma\work\p000055\g_Mon\ Peterson\071745_sml.ele_xxx.dgn JTPeterson