

**EDI MODEL 2018ECLip-NC CONFLICT MONITOR PROGRAMMING DETAIL**  
(remove jumpers and set switches as shown)

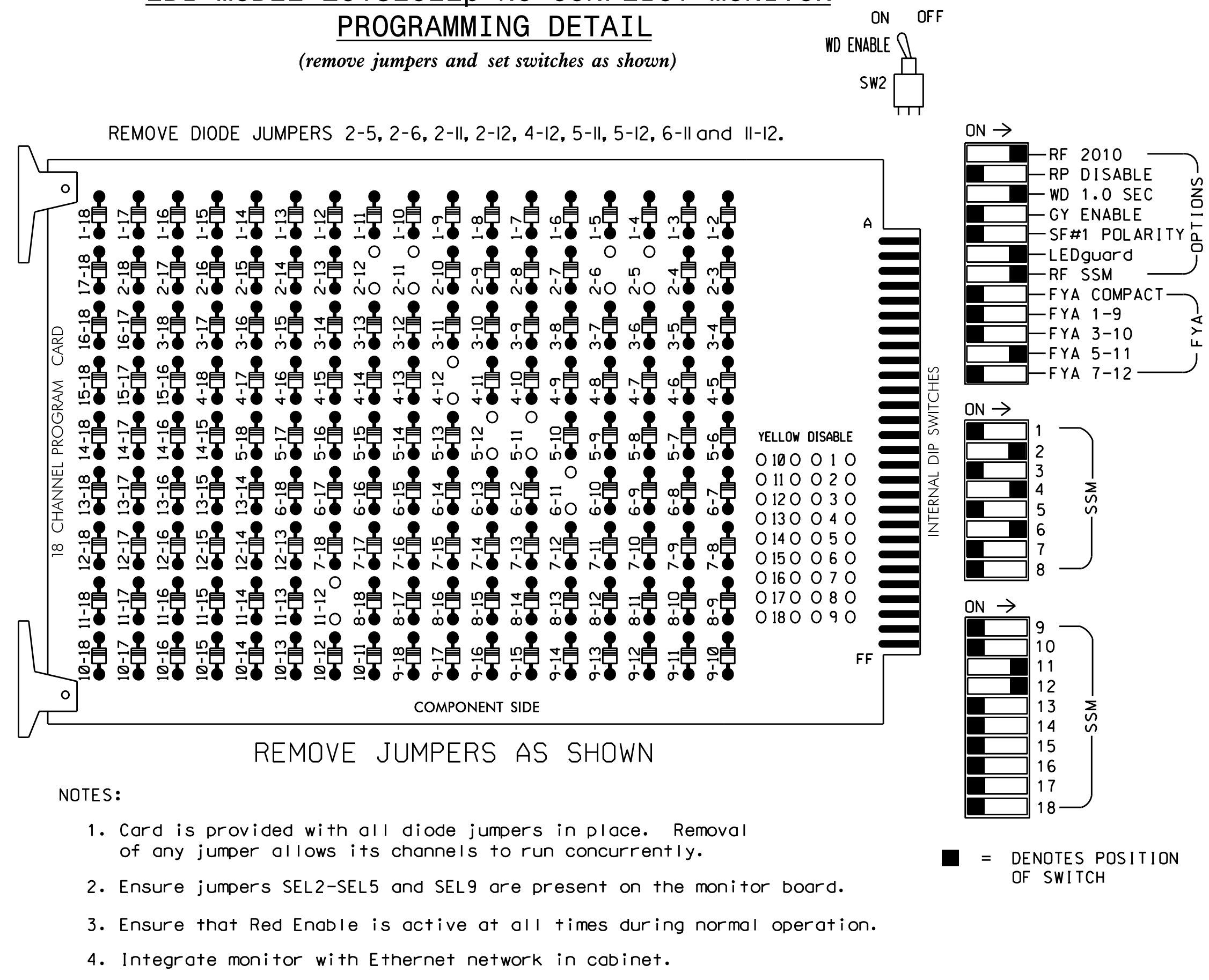

- NOTES:
- Card is provided with all diode jumpers in place. Removal of any jumper allows its channels to run concurrently.
  - Ensure jumpers SEL2-SEL5 and SEL9 are present on the monitor board.
  - Ensure that Red Enable is active at all times during normal operation.
  - Integrate monitor with Ethernet network in cabinet.

**NOTES**

- To prevent "flash-conflict" problems, insert red flash program blocks for all unused vehicle load switches in the output file. The installer shall verify that signal heads flash in accordance with the Signal Plans.
- Enable Simultaneous Gap-Out for all phases.
- Program phases 2 and 6 for Start Up In Green.
- Program phases 2 and 6 for Yellow Flash.
- The cabinet and controller are part of the High Point Signal System.

**EQUIPMENT INFORMATION**

CONTROLLER.....2070L  
 CABINET.....332 /W/ AUX  
 SOFTWARE.....ECONOLITE OASIS  
 CABINET MOUNT.....BASE  
 OUTPUT FILE POSITIONS...18 WITH AUX. OUTPUT FILE  
 LOAD SWITCHES USED.....S2,S5,S7,S8,AUX S4,AUX S5.  
 PHASES USED.....2,4,5,6.  
 OVERLAP "A".....NOT USED  
 OVERLAP "B".....NOT USED  
 OVERLAP "C".....5+6  
 OVERLAP "D".....4+5

**SIGNAL HEAD HOOK-UP CHART**

LOAD SWITCH NO.	S1	S2	S3	S4	S5	S6	S7	S8	S9	S10	S11	S12	AUX S1	AUX S2	AUX S3	AUX S4	AUX S5	AUX S6
CMU CHANNEL NO.	1	2	13	3	4	14	5	6	15	7	8	16	9	10	17	11	12	18
PHASE	1	2	2 PED	3	4	4 PED	5	6	6 PED	7	8	8 PED	OLA	OLB	SPARE	OLC	OLD	SPARE
SIGNAL HEAD NO.	NU	21,22	NU	NU	41,42	NU	51	61,62	NU	NU	NU	NU	NU	NU	NU	51	43	NU
RED		128						134									A101	
YELLOW		129					*	135										
GREEN		130						136										
RED ARROW					101												A114	
YELLOW ARROW					102												A115	A102
FLASHING YELLOW ARROW																	A116	
GREEN ARROW					103		133											A103

NU = Not Used  
 \* Denotes install load resistor. See load resistor installation detail this sheet.  
 \* See pictorial of head wiring in detail below.

**BIMODAL SIGNAL WIRING DETAIL**  
(wire signal heads as shown)

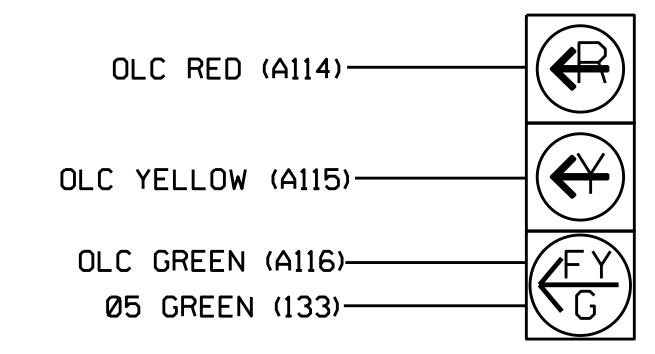

51

- The sequence display for this signal requires special logic programming. See sheet 2 for programming instructions.

**INPUT FILE POSITION LAYOUT**  
(front view)

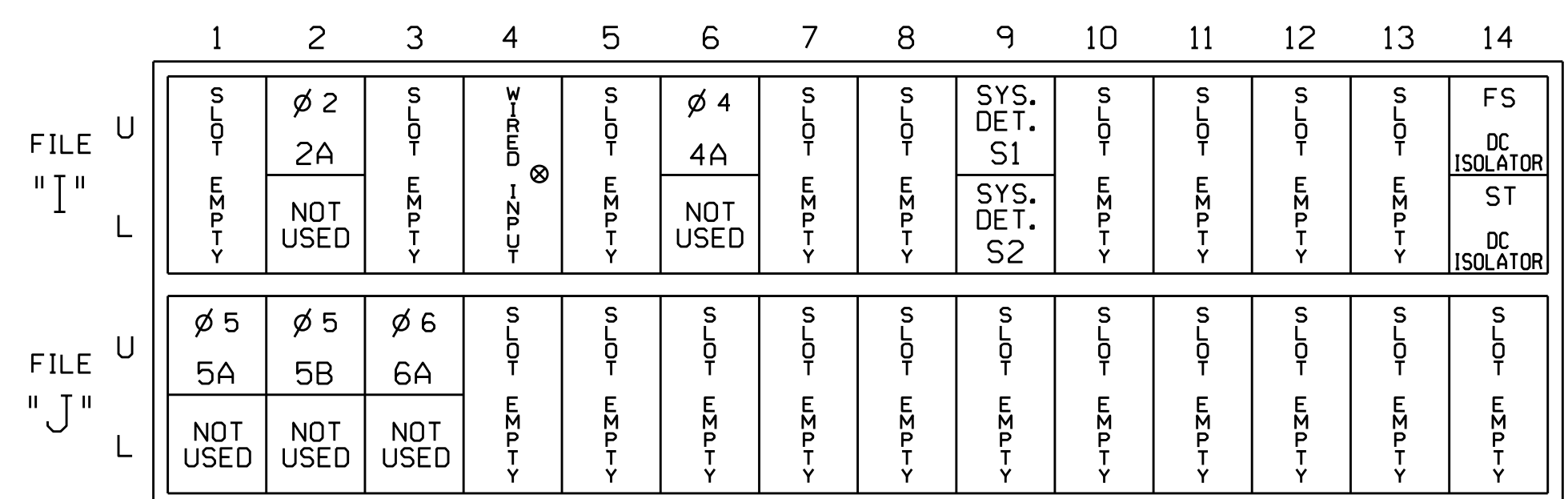

EX.: 1A, 2A, ETC. = LOOP NO.'S  
 FS = FLASH SENSE  
 ST = STOP TIME  
 ⊗ Wired Input - Do not populate slot with detector card

**INPUT FILE CONNECTION & PROGRAMMING CHART**

LOOP NO.	LOOP TERMINAL	INPUT FILE POS.	PIN NO.	INPUT ASSIGNMENT NO.	DETECTOR NO.	NEMA PHASE	CALL	EXTEND	FULL TIME DELAY	STRETCH TIME	DELAY TIME
2A	TB2-5,6	I2U	39	1	2	2	Y	Y			
4A	TB4-9,10	I6U	41	3	4	4	Y	Y			3
* S1	TB6-9,10	I9U	60	22	11	SYS					
* S2	TB6-11,12	I9L	62	24	13	SYS					
5A <sup>1</sup>	TB3-1,2	J1U	55	17	5	5	Y	Y			15
		I4U	47	9	22	2	Y	Y			
5B	TB3-5,6	J2U	40	2	6	5	Y	Y			15
6A	TB3-9,10	J3U	64	26	36	6	Y	Y			

<sup>1</sup>Add jumper from J1-W to I4-W, on rear of input file.  
 \* System detector only. Remove the vehicle phase assigned to this detector in the default programming.

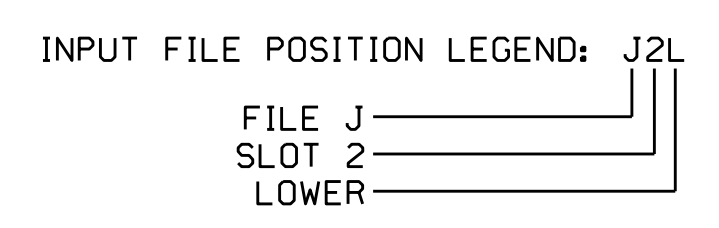

**LOAD RESISTOR INSTALLATION DETAIL**  
(install resistors as shown below)

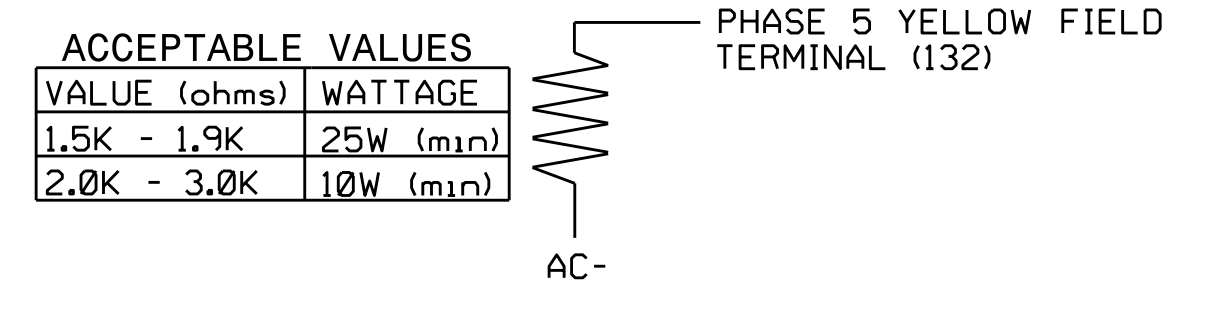

ELECTRICAL DETAIL SHEET 1 OF 2

Electrical and Programming Details For: SR 1486 (Greensboro Rd./W. Main St.) at SR 1536 (Penny Rd.)

Division 7 Guilford County, NC, as Jamestown

PLAN DATE: September 2014 REVIEWED BY: JTR

PREPARED BY: James Peterson REVIEWED BY:

750 N. Greenfield Pkwy, Garner, NC 27529

SEAL: JOHN T. ROWE, JR., PROFESSIONAL ENGINEER, STATE OF NORTH CAROLINA, SEAL 008453

DocuSigned by: John T. Rowe, Jr. 4/30/2015

SIG. INVENTORY NO. 07-1323

30-486-2015 1/2/22 S:\IT\55141\55141\SIGNAL\work\output\sig\_mon\eter\_son071323\_sml.ele...xxx.dgn J.peterson