

**EDI MODEL 2018ECLIP-NC CONFLICT MONITOR
PROGRAMMING DETAIL**

(remove jumpers and set switches as shown)

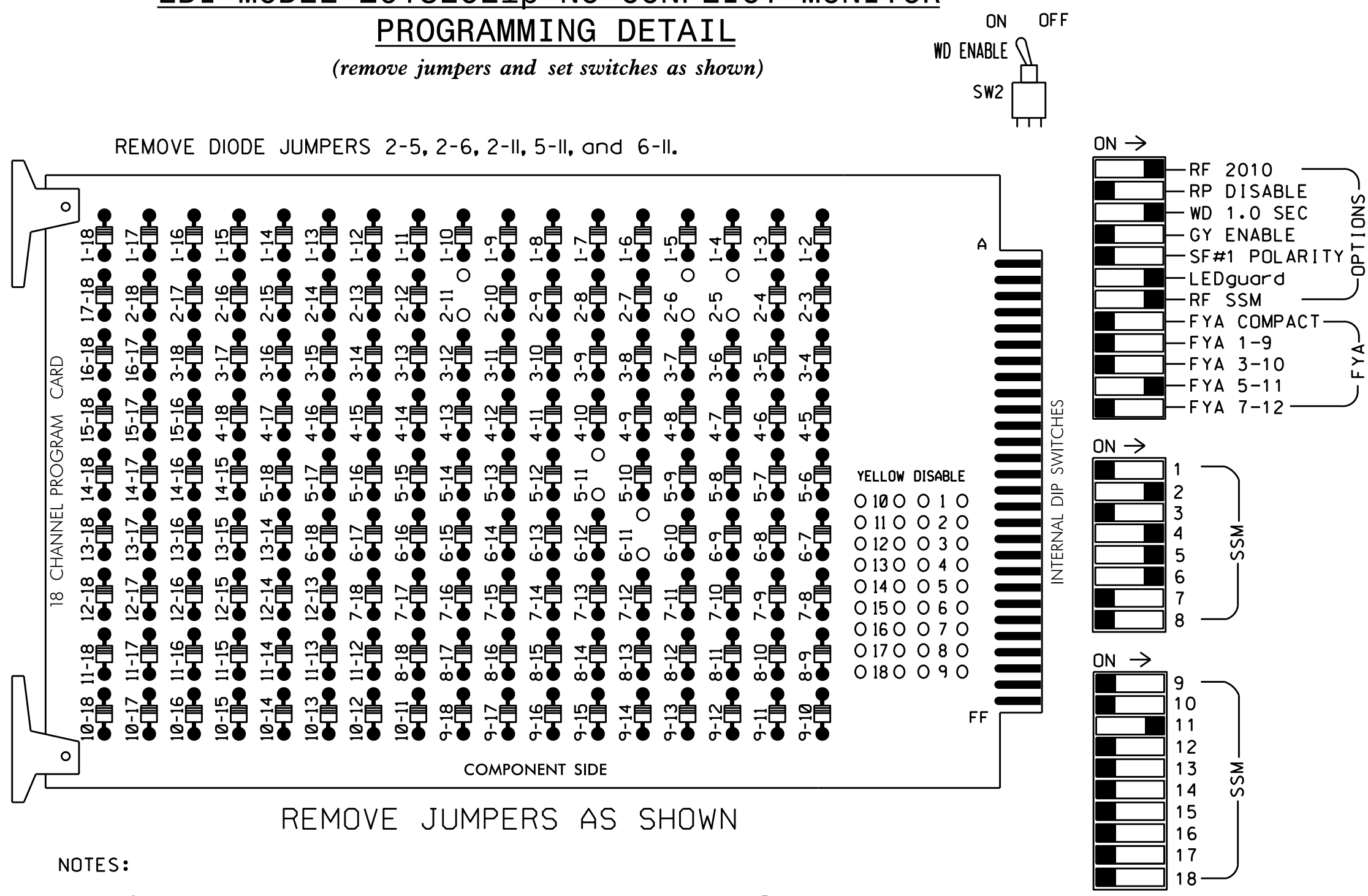

- NOTES:**
- Card is provided with all diode jumpers in place. Removal of any jumper allows its channels to run concurrently.
 - Ensure jumpers SEL2-SEL5 and SEL9 are present on the monitor board.
 - Ensure that Red Enable is active at all times during normal operation.
 - Integrate monitor with Ethernet network in cabinet.

NOTES

- To prevent "flash-conflict" problems, insert red flash program blocks for all unused vehicle load switches in the output file. The installer shall verify that signal heads flash in accordance with the Signal Plans.
- Enable Simultaneous Gap-Out for all phases.
- Program phases 2 and 6 for Variable Initial and Gap Reduction.
- Program phases 2 and 6 for Start Up In Green.
- Program phases 2 and 6 for Yellow Flash.
- The cabinet and controller are part of the High Point Signal System.

EQUIPMENT INFORMATION

CONTROLLER.....2070
 CABINET.....332 W/ AUX
 SOFTWARE.....ECONOLITE OASIS
 CABINET MOUNT.....BASE
 OUTPUT FILE POSITIONS...18 WITH AUX. OUTPUT FILE
 LOAD SWITCHES USED.....S2,S5,S7,S8,AUX S4
 PHASES USED.....2,4,5,6
 OVERLAP "A".....NOT USED
 OVERLAP "B".....NOT USED
 OVERLAP "C".....5+6
 OVERLAP "D".....NOT USED

SIGNAL HEAD HOOK-UP CHART

LOAD SWITCH NO.	S1	S2	S3	S4	S5	S6	S7	S8	S9	S10	S11	S12	AUX S1	AUX S2	AUX S3	AUX S4	AUX S5	AUX S6	
CMU CHANNEL NO.	1	2	13	3	4	14	5	6	15	7	8	16	9	10	17	11	12	18	
PHASE	1	2	2 PED	3	4	4 PED	5	6	6 PED	7	8	8 PED	OLA	OLB	SPARE	OLC	OLD	SPARE	
SIGNAL HEAD NO.	NU	21,22	NU	NU	41,42	62	NU	42	51*	61,62	NU	NU	NU	NU	NU	51*	NU	NU	
RED		128			101			*		134									
YELLOW		129			102					135									
GREEN		130			103					136									
RED ARROW																		A114	
YELLOW ARROW						102		132											A115
FLASHING YELLOW ARROW																			A116
GREEN ARROW						103		133	133										

NU = Not Used
 * Denotes install load resistor. See load resistor installation detail this sheet.
 ★ See pictorial of head wiring in detail below.

INPUT FILE POSITION LAYOUT

(front view)

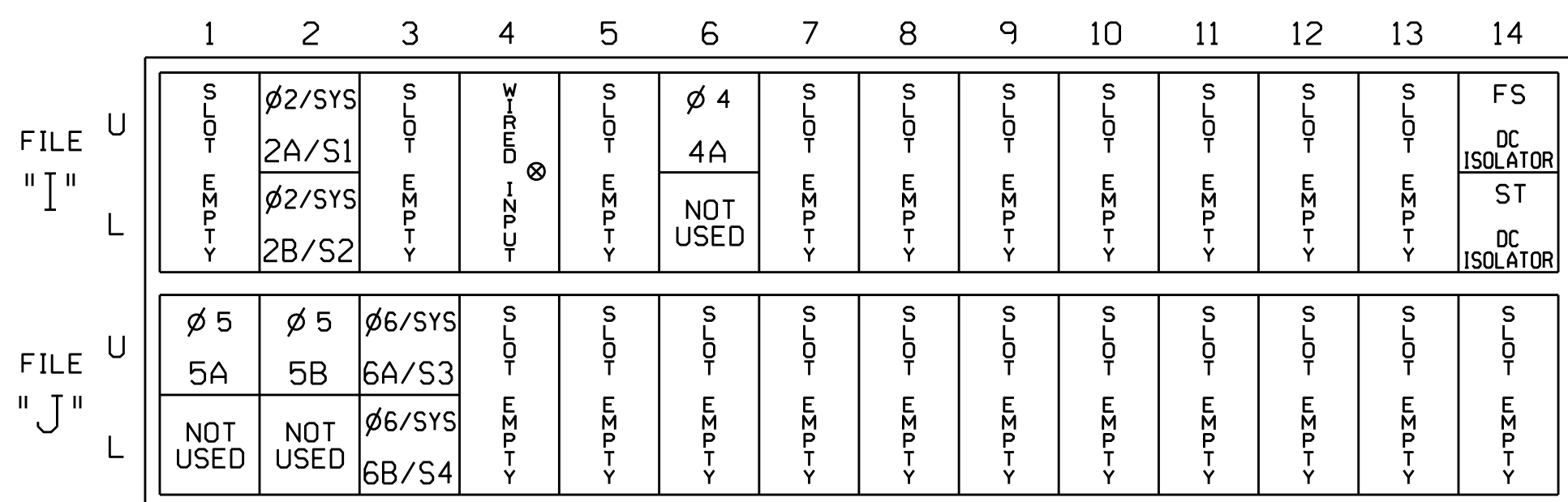

EX.: 1A, 2A, ETC. = LOOP NO.'S

FS = FLASH SENSE
 ST = STOP TIME

⊗ Wired Input - Do not populate slot with detector card

INPUT FILE CONNECTION & PROGRAMMING CHART

LOOP NO.	LOOP TERMINAL	INPUT FILE POS.	PIN NO.	INPUT ASSIGNMENT NO.	DETECTOR NO.	NEMA PHASE	CALL	EXTEND	FULL TIME DELAY	STRETCH TIME	DELAY TIME
2A/S1	TB2-5,6	I2U	39	1	2	2/SYS	Y	Y			
2B/S2	TB2-7,8	I2L	43	5	12	2/SYS	Y	Y			
4A	TB4-9,10	I6U	41	3	4	4	Y	Y			
5A ¹	TB3-1,2	J1U	55	17	5	5	Y	Y			3
	-	I4U	47	9	22	2	Y	Y	Y		3
5B	TB3-5,6	J2U	40	2	6	5	Y	Y			15
6A/S3	TB3-9,10	J3U	64	26	36	6/SYS	Y	Y			
6B/S4	TB3-11,12	J3L	77	39	46	6/SYS	Y	Y			

¹Add jumper from J1-W to I4-W. on rear of input file.

INPUT FILE POSITION LEGEND: J2L

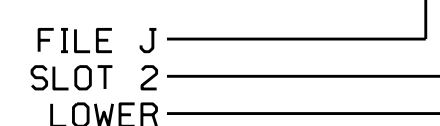

FYA SIGNAL WIRING DETAIL

(wire signal head as shown)

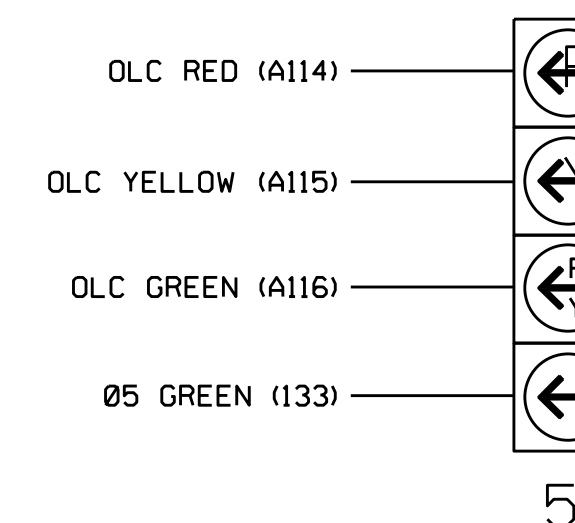

NOTE

The sequence display for signal head 51 requires special logic programming. See sheet 2 for programming instructions.

THIS ELECTRICAL DETAIL IS FOR
 THE SIGNAL DESIGN: 07-0856
 DESIGNED: July 2014
 SEALED: 4/2/2015
 REVISED: N/A

LOAD RESISTOR INSTALLATION DETAIL

(install resistor as shown below)

VALUE (ohms)	WATTAGE
1.5K - 1.9K	25W (min)
2.0K - 3.0K	10W (min)

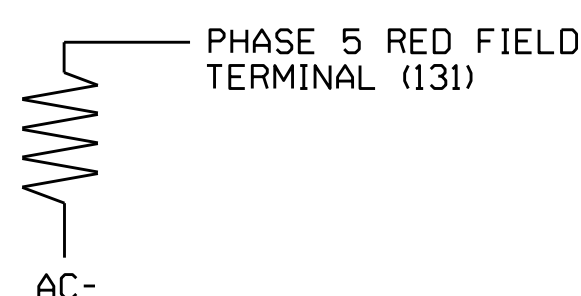

Electrical Detail - Sheet 1 of 2

ELECTRICAL AND PROGRAMMING DETAILS FOR: Prepared In the Offices of: 750 N. Greenfield Pkwy, Garner, NC 27529	SR 1113 (E. Kivett Drive) at SR 1332 (S. Scientific Street)	SEAL
	Division 7 Guilford County High Point PLAN DATE: August 2014 REVIEWED BY: <i>STR</i> PREPARED BY: S. Armstrong REVIEWED BY:	REVISIONS INIT. DATE