

EDI MODEL 2018EClip-NC CONFLICT MONITOR PROGRAMMING DETAIL
(remove jumpers and set switches as shown)

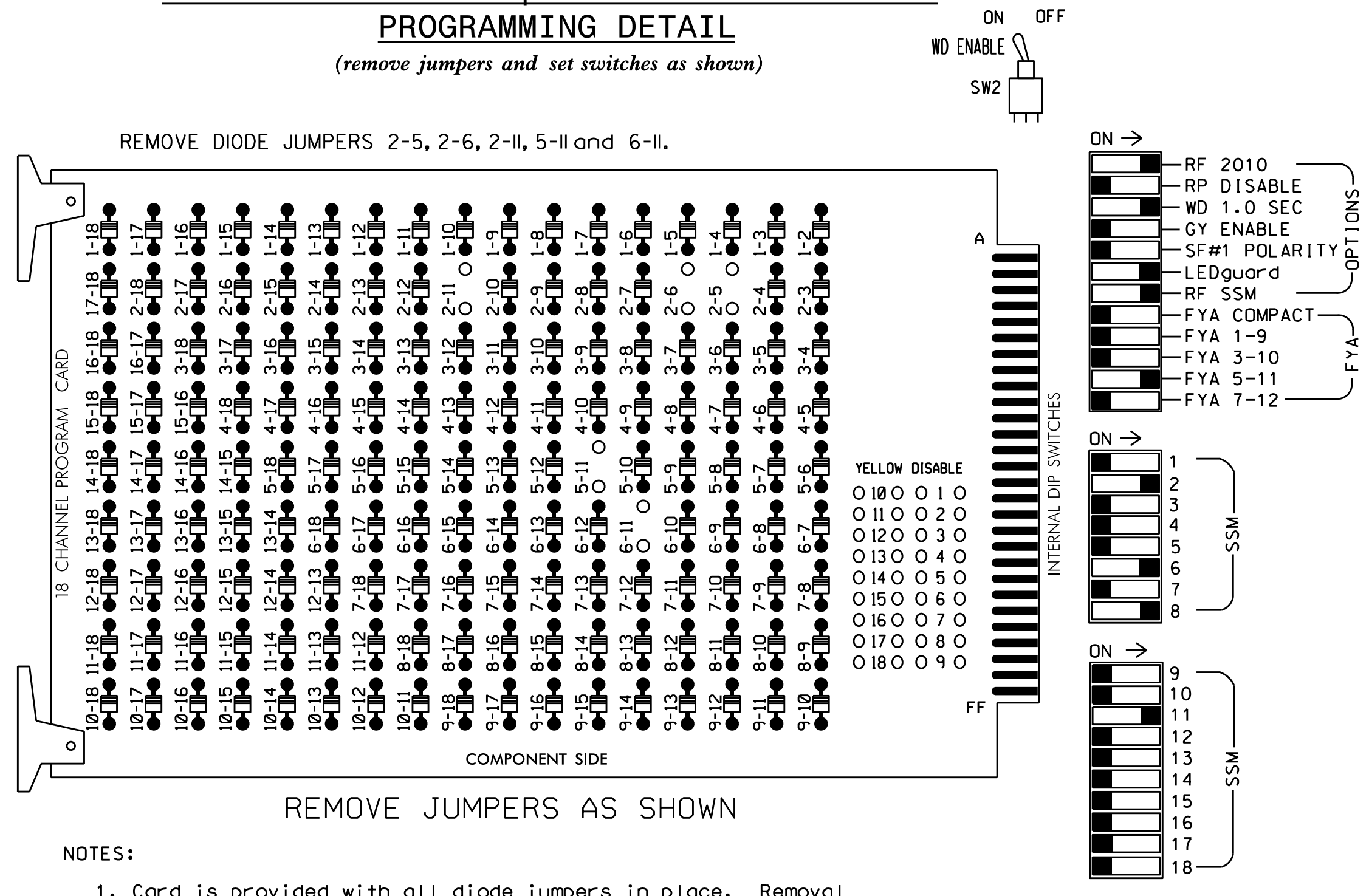

- NOTES:
- Card is provided with all diode jumpers in place. Removal of any jumper allows its channels to run concurrently.
 - Ensure jumpers SEL2-SEL5 and SEL9 are present on the monitor board.
 - Ensure that Red Enable is active at all times during normal operation.
 - Integrate monitor with Ethernet network in cabinet.

NOTES

- To prevent "flash-conflict" problems, insert red flash program blocks for all unused vehicle load switches in the output file. The installer shall verify that signal heads flash in accordance with the Signal Plans.
- Enable Simultaneous Gap-Out for all phases.
- Program phases 2 and 6 for Start Up In Green.
- Program phases 2 and 6 for Yellow Flash.
- The cabinet and controller are part of the High Point Signal System.

SIGNAL HEAD HOOK-UP CHART

LOAD SWITCH NO.	S1	S2	S3	S4	S5	S6	S7	S8	S9	S10	S11	S12	AUX S1	AUX S2	AUX S3	AUX S4	AUX S5	AUX S6	
CMU CHANNEL NO.	1	2	13	3	4	14	5	6	15	7	8	16	9	10	17	11	12	18	
PHASE	1	2	2 PED	3	4	4 PED	5	6	6 PED	7	8	8 PED	OLA	OLB	SPARE	OLC	OLD	SPARE	
SIGNAL HEAD NO.	NU	22,23	NU	NU	NU	NU	51	61,62	NU	NU	81,82	NU	NU	NU	NU	51	NU	NU	
RED		128						134			107								
YELLOW		129					*	135			108								
GREEN		130						136			109								
RED ARROW																		A114	
YELLOW ARROW																			A115
FLASHING YELLOW ARROW																			A116
GREEN ARROW								133											

NU = Not Used
* Denotes install load resistor. See load resistor installation detail this sheet.
* See pictorial of head wiring in detail below.

EQUIPMENT INFORMATION

CONTROLLER.....2070
CABINET.....332 /W/ AUX
SOFTWARE.....ECONOLITE OASIS
CABINET MOUNT.....BASE
OUTPUT FILE POSITIONS...18 WITH AUX. OUTPUT FILE
LOAD SWITCHES USED....S2,S7,S8,S11,AUX S4.
PHASES USED.....2,5,6,8.
OVERLAP "A".....NOT USED
OVERLAP "B".....NOT USED
OVERLAP "C".....5+6
OVERLAP "D".....NOT USED

INPUT FILE POSITION LAYOUT

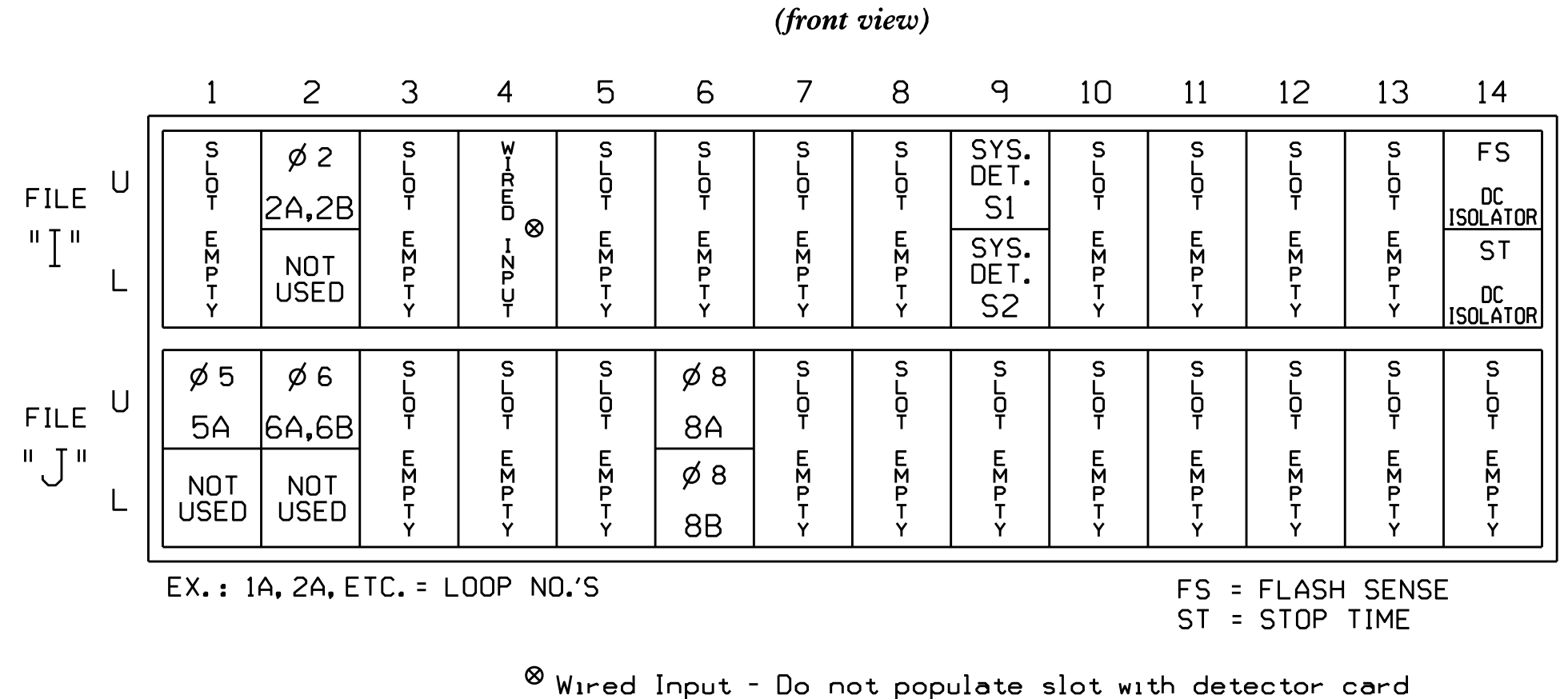

EX.: 1A, 2A, ETC. = LOOP NO.'S
FS = FLASH SENSE
ST = STOP TIME
⊗ Wired Input - Do not populate slot with detector card

INPUT FILE CONNECTION & PROGRAMMING CHART

LOOP NO.	LOOP TERMINAL	INPUT FILE POS.	PIN NO.	INPUT ASSIGNMENT NO.	DETECTOR NO.	NEMA PHASE	CALL	EXTEND	FULL TIME DELAY	STRETCH TIME	DELAY TIME
2A,2B	TB2-5,6	I2U	39	1	2	2	Y	Y			
* S1	TB6-9,10	I9U	60	22	11	SYS					
* S2	TB6-11,12	I9L	62	24	13	SYS					
5A ¹	TB3-1,2	J1U	55	17	5	5	Y	Y			15
	-	I4U	47	9	22	2	Y	Y			
6A,6B	TB3-5,6	J2U	40	2	6	6	Y	Y			
8A	TB5-9,10	J6U	42	4	8	8	Y	Y			
8B	TB5-11,12	J6L	46	8	18	8	Y	Y			15

¹Add jumper from J1-W to I4-W, on rear of input file.
* System detector only. Remove the vehicle phase assigned to this detector in the default programming.

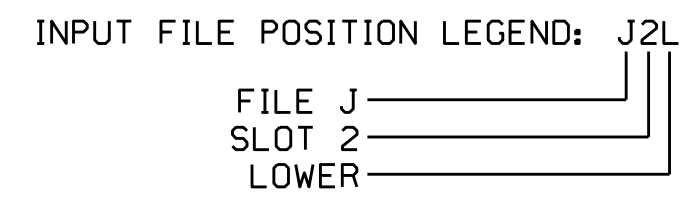

4 SECTION FYA PPLT SIGNAL WIRING DETAIL

(wire signal heads as shown)

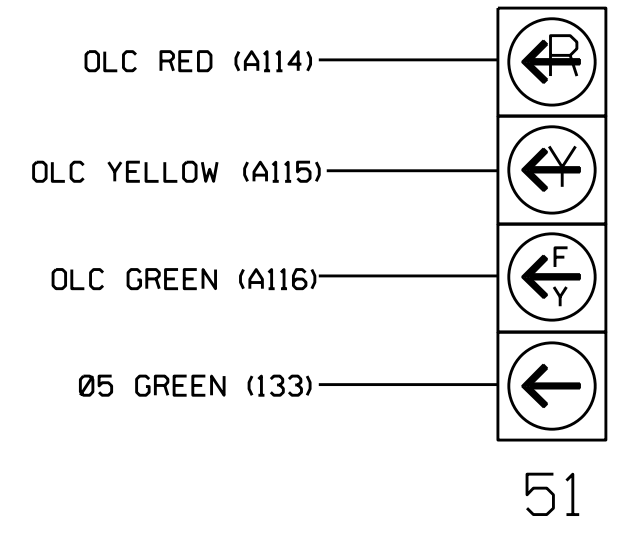

NOTE

- The sequence display for this signal requires special logic programming. See sheet 2 for programming instructions.

THIS ELECTRICAL DETAIL IS FOR THE SIGNAL DESIGN: 07-0414
DESIGNED: March 2014
SEALED: 3-04-15
REVISED: N/A

LOAD RESISTOR INSTALLATION DETAIL

(install resistors as shown below)

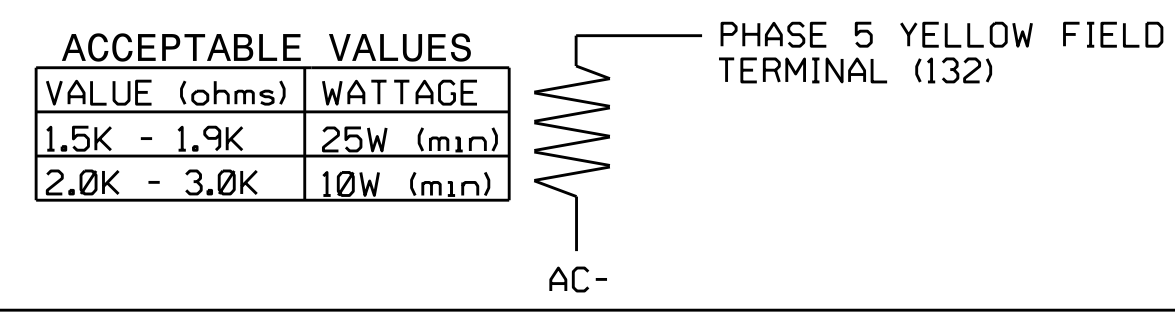

ELECTRICAL DETAIL SHEET 1 OF 2

Prepared in the Offices of:
TRANSPORTATION MOBILITY AND SAFETY DIVISION
STATE OF NORTH CAROLINA
Signal Management Section
750 N. Greenfield Pkwy, Garner, NC 27529

SR 1300
(W. Green Dr./W. Fairfield Rd.)
at
I-85 Bus./US 29 NB-70 EB Ramps

Division 7 Guilford County High Point
PLAN DATE: September 2014 REVIEWED BY: JTR
PREPARED BY: James Peterson REVIEWED BY:

SEAL
PROFESSIONAL ENGINEER
JOHN T. ROWE, JR.
DATE: 3/5/2015
SIC. INVENTORY NO. 07-0414

06-2015-2015 06-52
S:\IT\SSM\15-SIGNAL\work\gpc\sig_Mon\ Peterson\070414_sml.ele...xxx.dgn
J. Peterson