

USE TYPICAL SECTION NO. 7
 -Y2- STA. 10+00.00 TO 10+53.13
 NOTES:
 MILL AS NEEDED.

C1	3" S9.5B	E5	5" B25.0B
C2	VAR. S9.5B	J	10" ABC
C3	3" S9.5C	P	PRIME COAT
C4	2" S9.5B	R1	2'-6" C & G
C5	1.5" S9.5B	R2	5" CONC. ISLAND
D1	4" I19.0B	S	4" STAMPED SIDEWALK
D2	VAR. I19.0B	T	EARTH MATERIAL
D3	3" I19.0C	U	EXISTING PVMNT
E1	4.5" B25.0B	V1	3" MILLING
E2	7" B25.0B	V2	VARIABLE DEPTH MILLING 0" TO 3"
E3	VAR. B25.0B	W	WEDGING
E4	10.5" B25.0C		

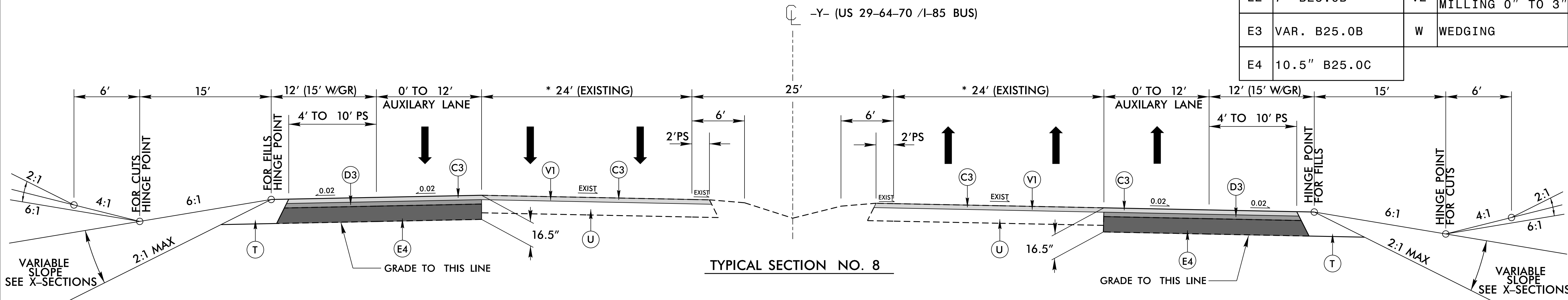

USE TYPICAL SECTION NO. 8
 -Y- STA. 11+50.00 TO STA. 39+00.00
 *MILL AND REPLACE AT SAME DEPTH, 3"
 NOTES:
 FROM -Y- STA. 34+20.00 TO 37+20.00 RT
 TAPER IN SHOULDER AND DITCH WIDTH TO
 TIE TO EXISTING (SEE X-SECTIONS).

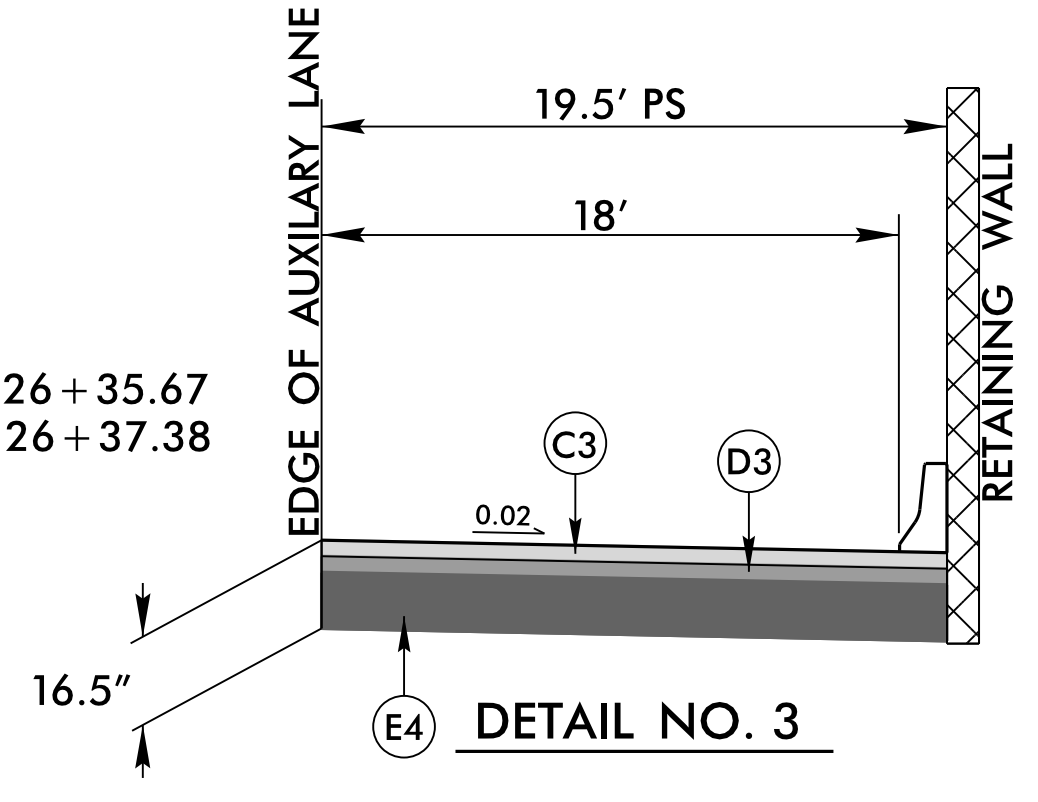
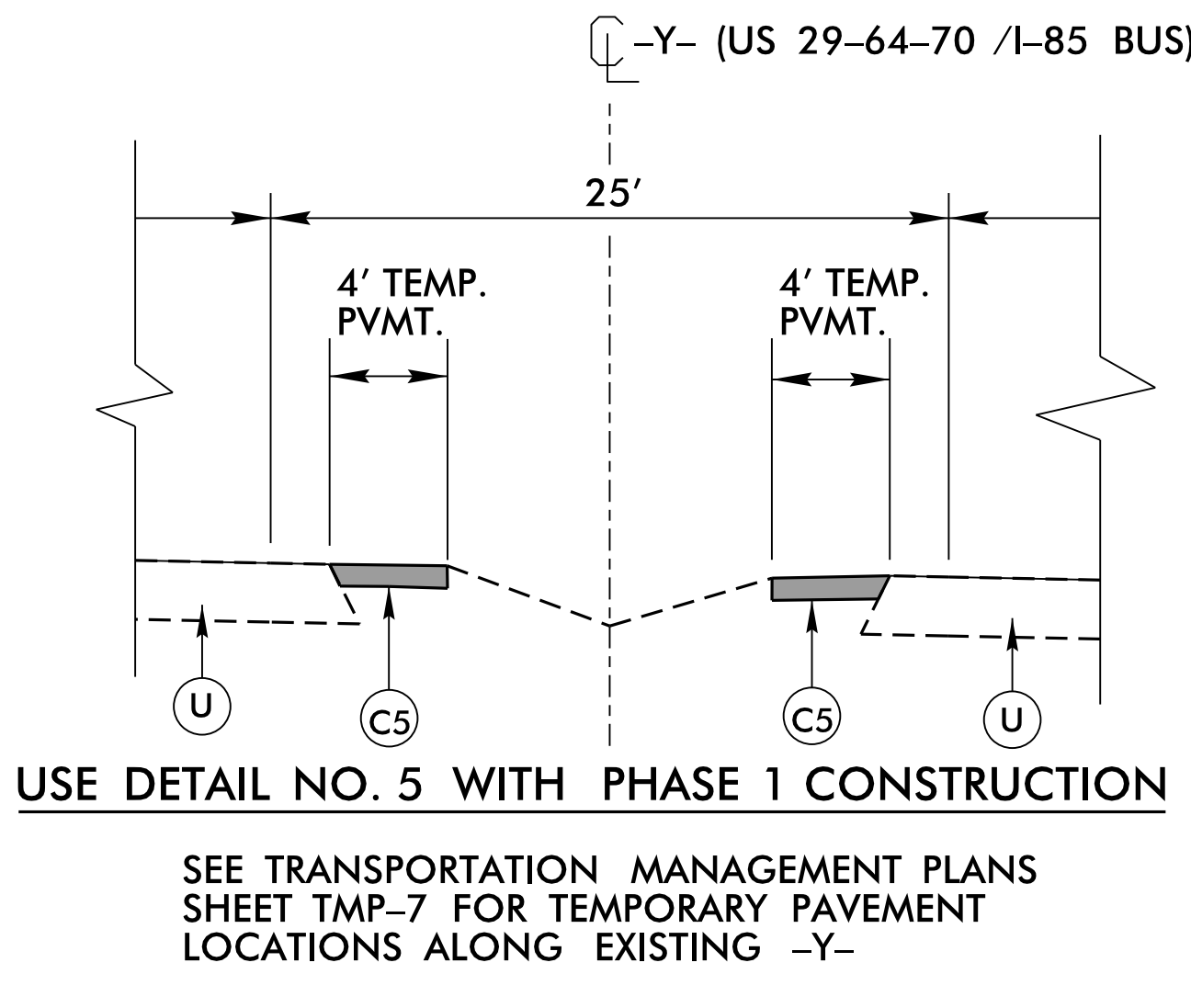
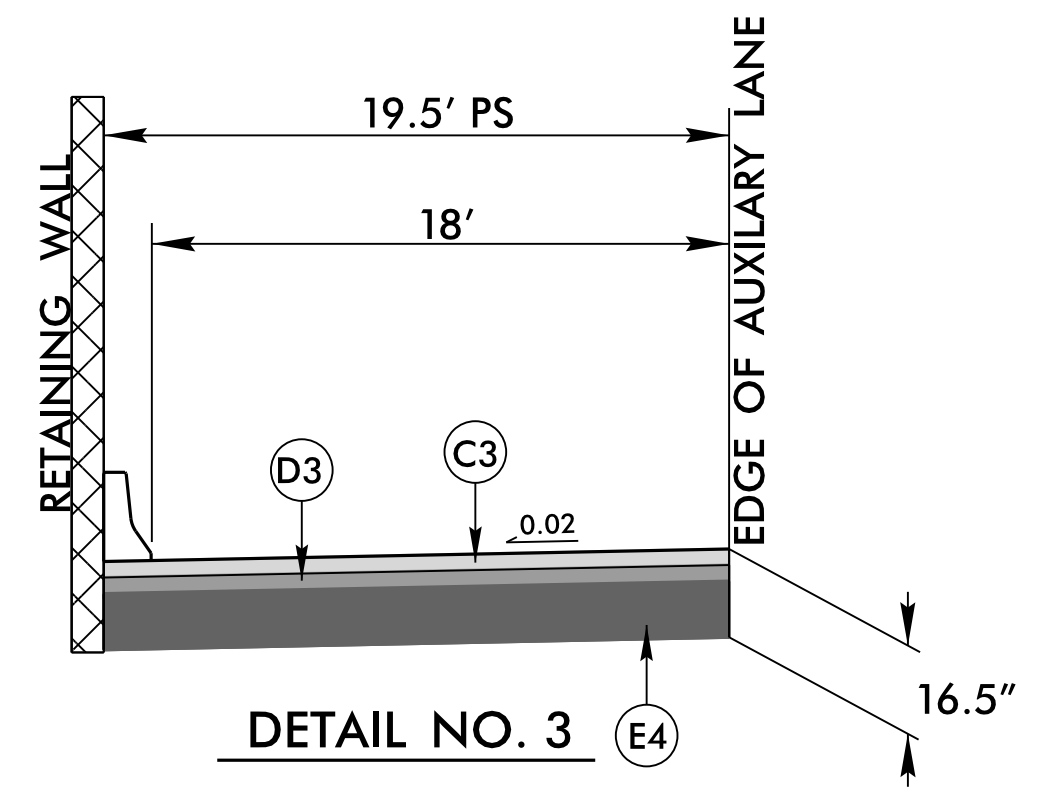

USE DETAIL NO. 3 WITH
 TYPICAL SECTION NO. 8
 LT: -Y- STA. 24+87.00 TO 26+35.67
 RT: -Y- STA. 24+39.00 TO 26+37.38

USE DETAIL NO. 5 WITH PHASE 1 CONSTRUCTION
 SEE TRANSPORTATION MANAGEMENT PLANS
 SHEET TMP-7 FOR TEMPORARY PAVEMENT
 LOCATIONS ALONG EXISTING -Y-

8/17/99
 23 JUL 2015 07:48 E:\3159_Rdy_psh_tup_02A-4.dgn
 3:58:58 PM