

USE TYPICAL SECTION NO. 2
-L- STA. 8+00.00 TO 10+00.00

NOTES:
SEE PLANS FOR TURN LANES AND TAPERS.
* MAY NEED TO WARP FOR PROPER TIE TO -Y2-

C1	3" S9.5B	E5	5" B25.0B
C2	VAR. S9.5B	J	10" ABC
C3	3" S9.5C	P	PRIME COAT
C4	2" S9.5B	R1	2'-6" C & G
C5	1.5" S9.5B	R2	5" CONC. ISLAND
D1	4" I19.0B	S	4" STAMPED SIDEWALK
D2	VAR. I19.0B	T	EARTH MATERIAL
D3	3" I19.0C	U	EXISTING PVMNT
E1	4.5" B25.0B	V1	3" MILLING
E2	7" B25.0B	V2	VARIABLE DEPTH MILLING 0" TO 3"
E3	VAR. B25.0B	W	WEDGING
E4	10.5" B25.0C		

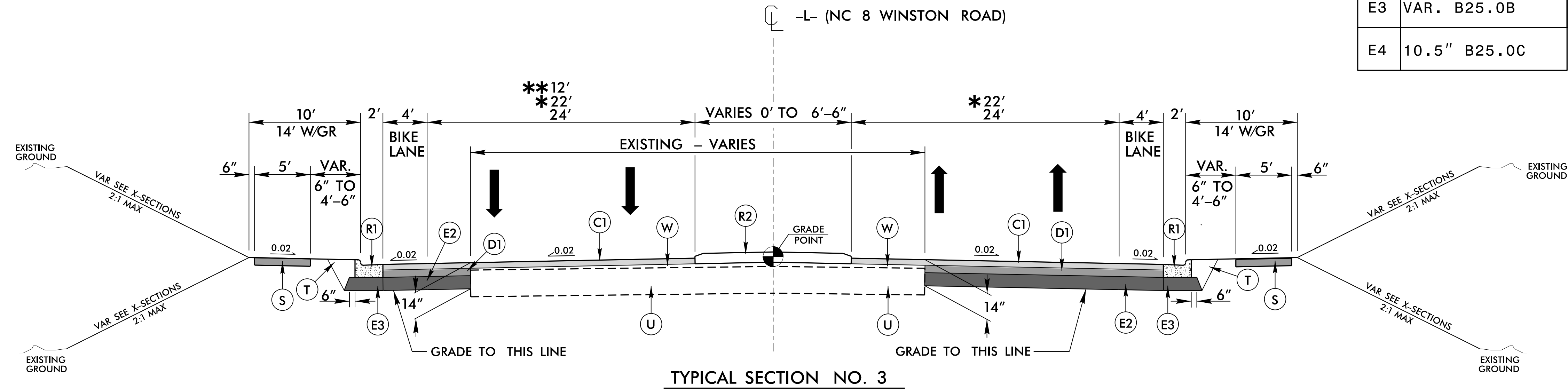

USE TYPICAL SECTION NO. 3
-L- STA. 10+00.00 TO 11+50.00
-L- STA. 18+50.00 TO 21+00.00

NOTES:
SEE PLANS FOR TURN LANES AND TAPERS.
* -L- STA. 19+64.72 TO 20+64.72
REDUCE 12' LANES TO 11' LANES LEFT AND RIGHT.
** -L- STA. 20+10.00 TO 21+00.00

USE DETAIL NO. 2 WITH PHASE I CONSTRUCTION
SEE TRANSPORTATION MANAGEMENT PLANS SHEET TMP-2D FOR TEMPORARY SIDEWALK LOCATIONS ALONG EXISTING -L-.

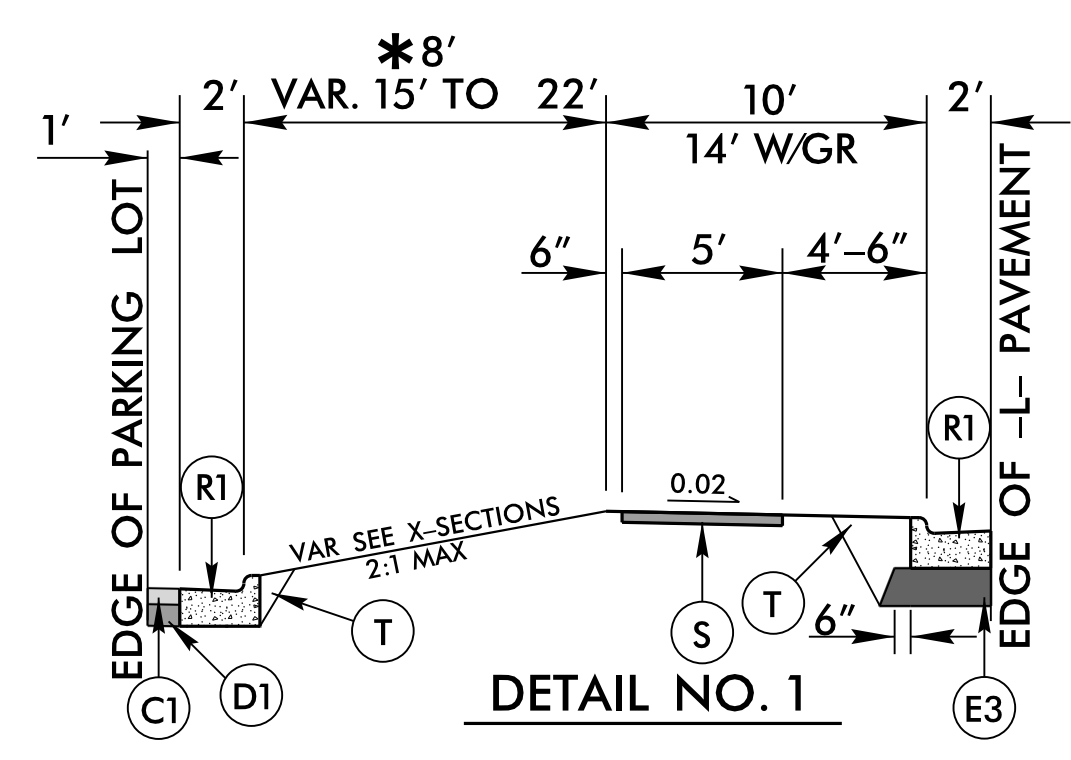
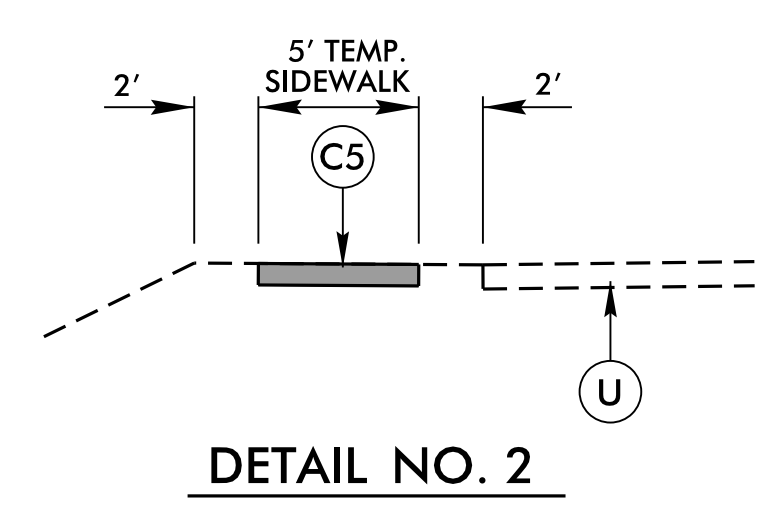

USE DETAIL NO. 1 WITH TYPICAL SECTION NO. 3 & NO. 4
LT: -L- STA. 17+94.00 TO STA. 19+20.00

8/17/99
 23 JUL 2015 07:48 E:\3159_Rdy_psh_tup_02A-2.dgn
 3:48:58 PM
 18F3AC6AF727432