

STATE OF NORTH CAROLINA  
DEPT. OF TRANSPORTATION  
DIVISION OF HIGHWAYS  
RALEIGH, N.C.

ENGLISH DETAIL DRAWING FOR  
**MANHOLE AND VALVE BOX ADJUSTMENTS**  
SHEET 1 OF 1  
**840D55**

GENERAL NOTES:

1. USE RAPID SET GROUT, MORTAR, OR CONCRETE THAT WILL TAKE FULL SET AND BECOME LOAD BEARING WITHIN SIXTY MINUTES OF PLACEMENT WITH A MINIMUM COMPRESSIVE STRENGTH OF 4000 PSI.
2. REMOVE ALL FAULTY EXISTING BRICKWORK AND REPLACE WITH NEW BRICK MASONRY.
3. SHEER CUT EXCAVATION FOR THE ADJUSTMENT ON ALL SIDES.
4. FILL AREA BELOW 8" DEPTH WITH 78M OR NO. 57 CLEAN STONE.
5. MIX MORTAR TO NCDOT SPECIFICATIONS.
6. MORTAR JOINTS  $\frac{1}{2}$ " +/-  $\frac{1}{8}$ "

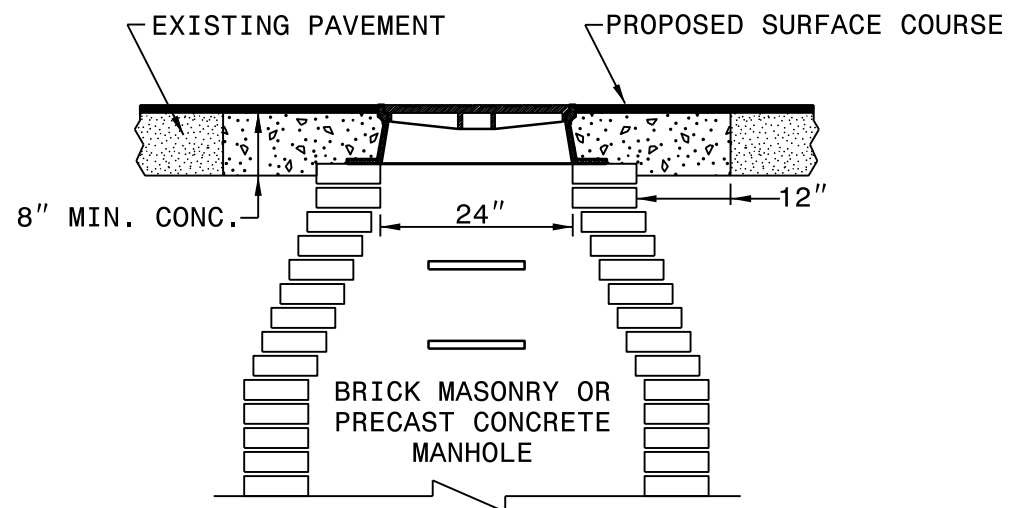

**MANHOLE CONCRETE ENCASEMENT**

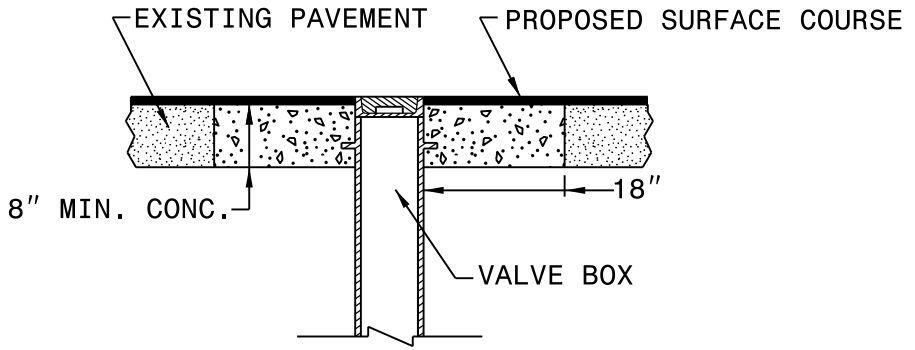

**VALVE BOX CONCRETE ENCASEMENT**

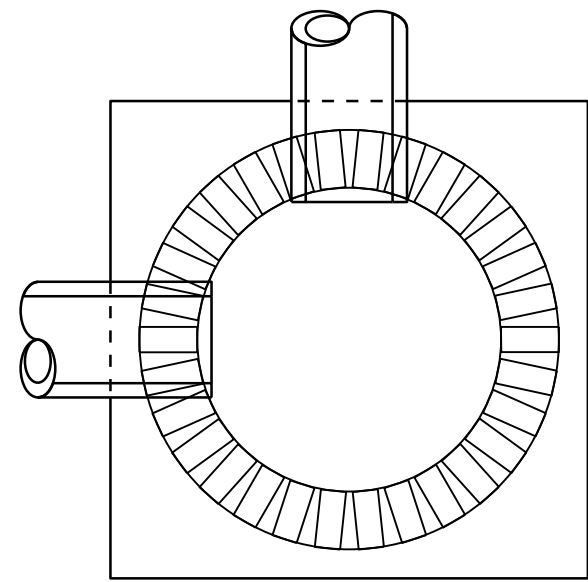

**ELEVATION VIEW**

PLACE BRICK ACCORDING TO ELEVATION VIEW

ENGLISH DETAIL DRAWING FOR  
**MANHOLE AND VALVE BOX ADJUSTMENTS**

SHEET 1 OF 1  
**840D55**

REVISIONS

19-AUG-2016 10:34  
C:\Resurfacing\Brunswick County\Belknap Let.US.17 & Various Sec. Rds\2016CPT.03.09.10101.Rdy.tup.dgn  
\$\$\$\$\$USERNAME\$\$\$\$\$