

PLAN

NOTES

- STIRRUPS IN CAP MAY BE SHIFTED AS NECESSARY TO CLEAR ANCHOR BOLTS.
- BACKWALL SHALL BE PLACED BEFORE APPLYING THE EPOXY PROTECTIVE COATING.
- THE TOP SURFACE AREAS OF THE END BENT CAPS SHALL BE CURED IN ACCORDANCE WITH THE STANDARD SPECIFICATIONS EXCEPT THE MEMBRANE CURING COMPOUND METHOD SHALL NOT BE USED.
- THE TOP SURFACE OF THE CAP EXCEPT THE BRIDGE SEAT BUILDUPS SHALL BE SLOPED TRANSVERSELY FROM THE FILL FACE TO THE BACK FACE AT THE RATE OF 2%.
- INSTALL THE 4" DIA. DRAIN PIPE THROUGH THE WING WALL AS REQUIRED FOR REINFORCED BRIDGE APPROACH FILLS, SEE THE ROADWAY PLANS. REINFORCING STEEL IN THE WING WALL MAY BE SHIFTED AS NECESSARY TO CLEAR THE DRAIN PIPE.
- FOR PILE SPLICE DETAILS, SEE SHEET 3 OF 3.
- FOR WING DETAILS, SEE SHEET 2 OF 3.
- THE CONCRETE IN THE SHADED AREA OF THE WING SHALL BE POURED AFTER THE BARRIER RAIL IS CAST IF SLIP FORMING IS USED.

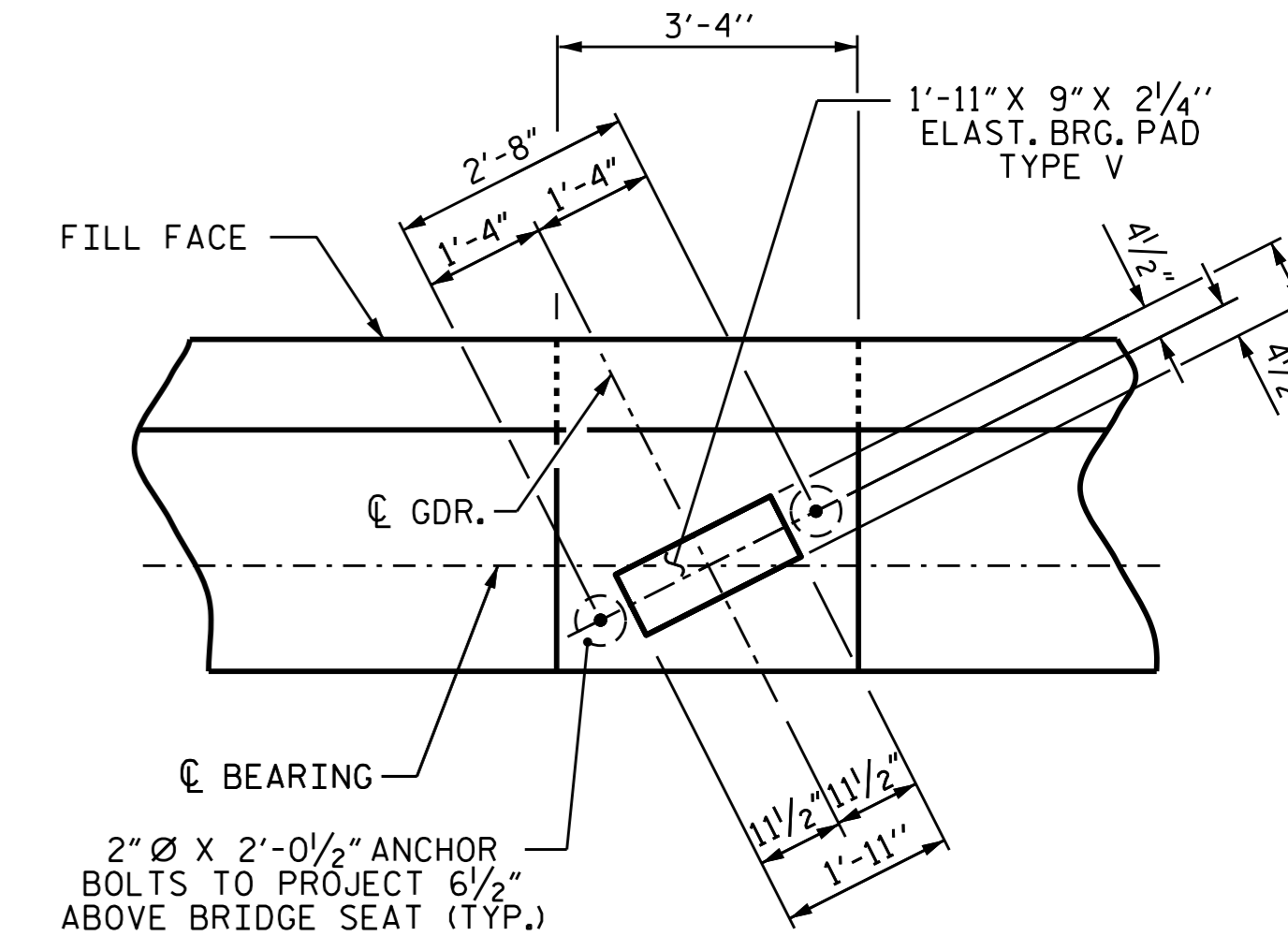

DETAIL "A"

(DIMENSIONS TYP. EA. GDR.)

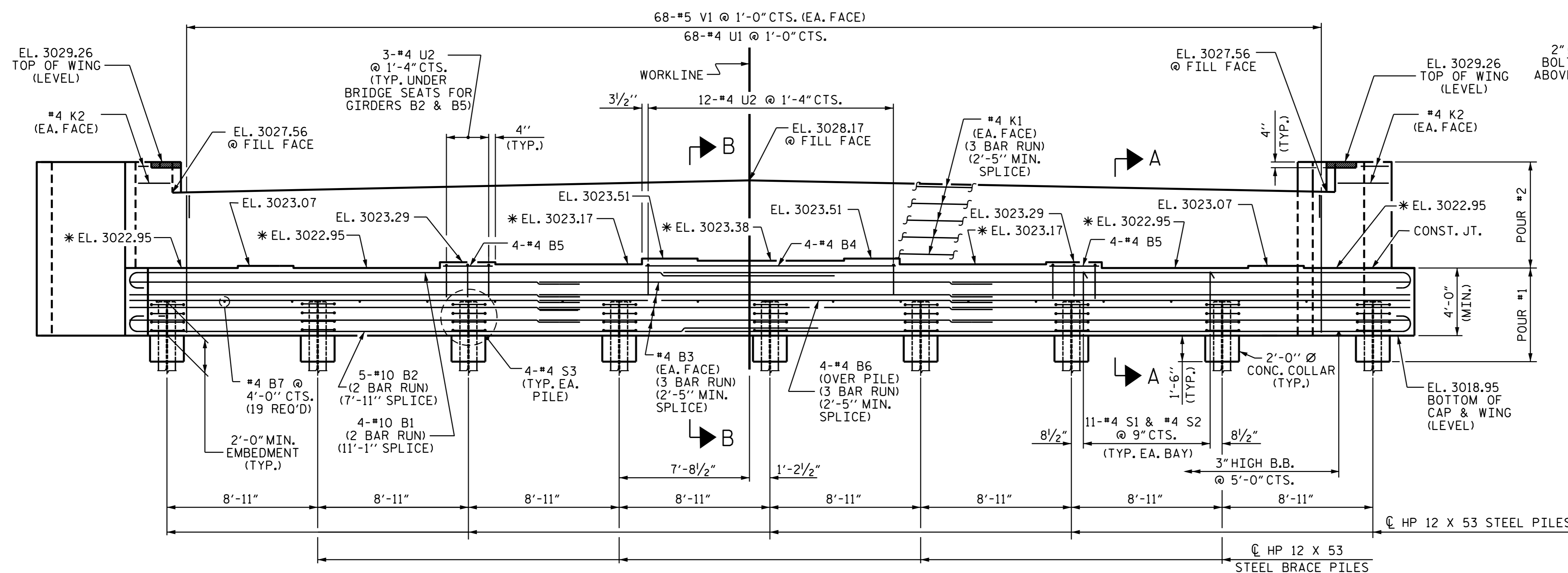

ELEVATION

* FOR LOCATION OF ELEVATION, SEE "SECTION A-A", SHEET 3 OF 3.

PROJECT NO. R-2915A
 WATAUGA/ASHE COUNTY
 STATION: 11+18.63 -L-

SHEET 1 OF 3

STATE OF NORTH CAROLINA
 DEPARTMENT OF TRANSPORTATION
 RALEIGH
 SUBSTRUCTURE
 END BENT No. 2



REVISIONS						SHEET NO. S-26
NO.	BY:	DATE:	NO.	BY:	DATE:	
1			3			TOTAL SHEETS 31
2			4			

DRAWN BY: V.X. NGUYEN DATE: 8-4-14
 CHECKED BY: J.P. MCCARTHA DATE: 3-16-15
 DESIGN ENGINEER OF RECORD: A.M. LEE DATE: 4-9-15