

**NOTES:**

- \* FOR LOCATION OF ELEVATIONS BETWEEN BRIDGE SEAT BUILDUPS, SEE SECTION A-A ON SHEET 3 OF 3.
- ▲ THIS ELEVATION TAKEN ON FILL FACE OF BACKWALL.
- STIRRUPS & U2 BARS IN CAP MAY BE SHIFTED AS NECESSARY TO CLEAR ANCHOR BOLTS.
- BACKWALL SHALL BE PLACED BEFORE APPLYING THE EPOXY PROTECTIVE COATING.
- THE TOP SURFACE OF THE CAP EXCEPT THE BRIDGE SEAT BUILDUPS SHALL BE SLOPED TRANSVERSELY FROM THE FILL FACE TO THE BACK FACE AT THE RATE OF 2%.
- THE TOP SURFACE AREAS OF THE END BENT CAPS SHALL BE CURED IN ACCORDANCE WITH THE STANDARD SPECIFICATIONS, EXCEPT THE MEMBRANE CURING COMPOUND METHOD SHALL NOT BE USED.
- INSTALL THE 4" DIA. DRAIN PIPE THROUGH THE WING WALL AS REQUIRED FOR REINFORCED BRIDGE APPROACH FILLS. SEE THE ROADWAY PLANS. REINFORCING STEEL IN THE WING WALL MAY BE SHIFTED AS NECESSARY TO CLEAR THE DRAIN PIPE.

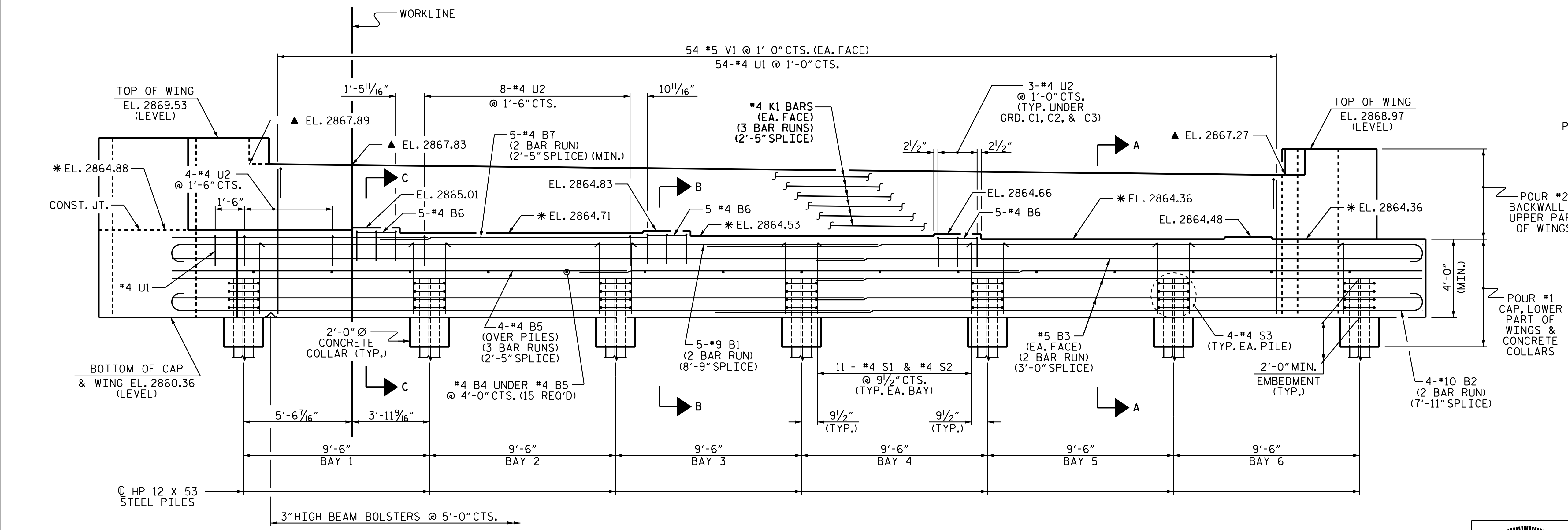
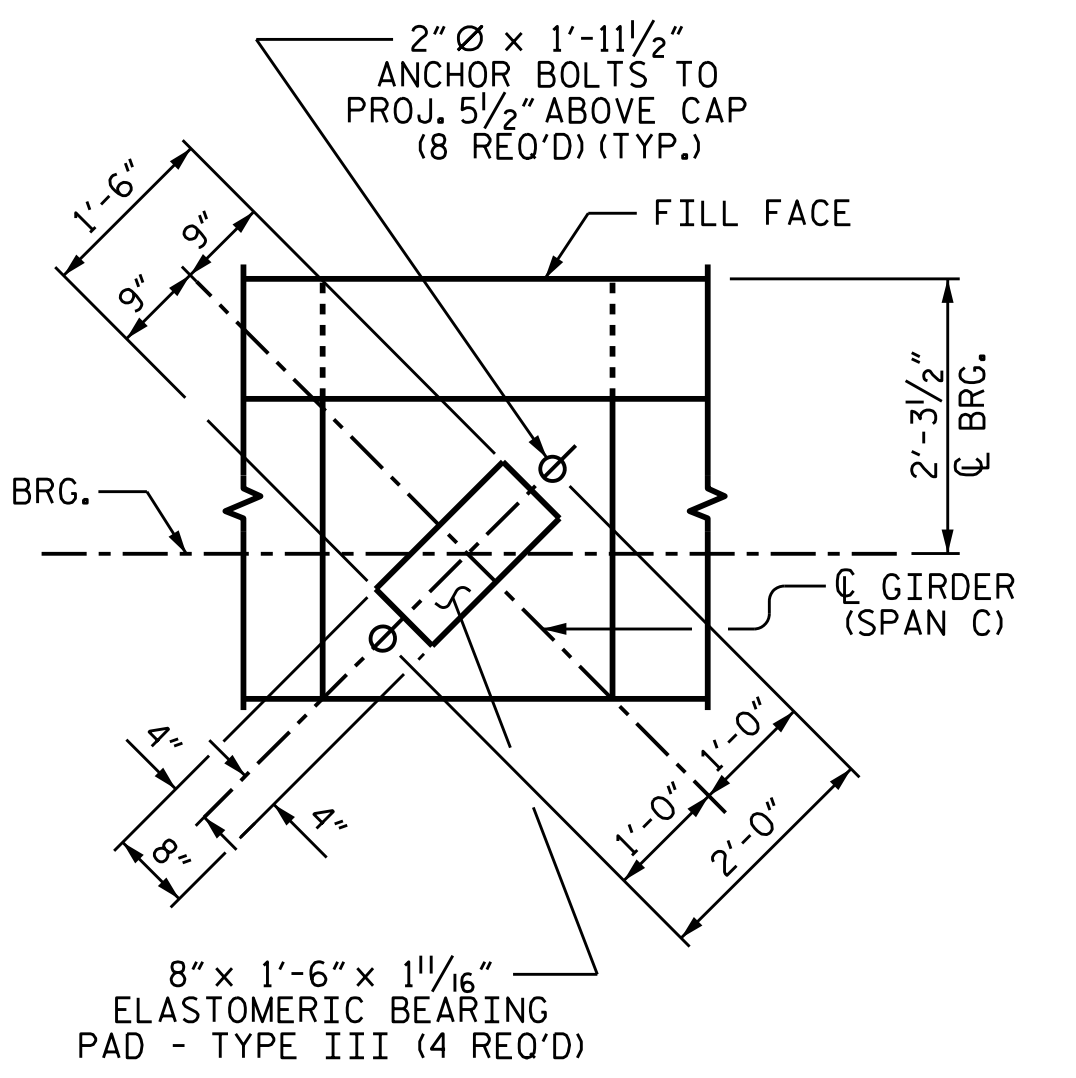
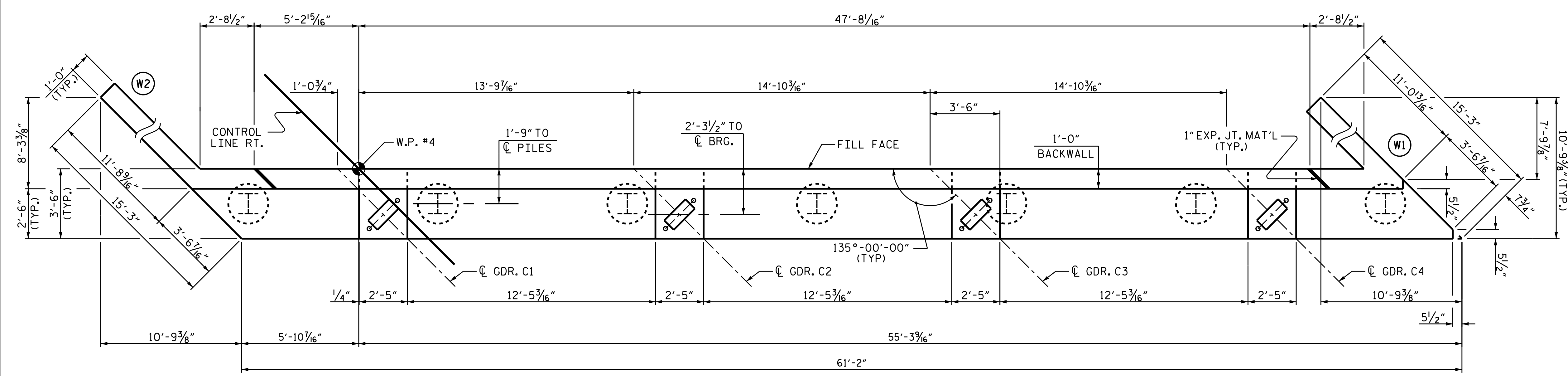

PROJECT NO. R-2915B  
ASHE COUNTY  
 STATION: 234+19.20 -L-  
 SHEET 1 OF 3

STATE OF NORTH CAROLINA  
 DEPARTMENT OF TRANSPORTATION  
 RALEIGH

**SUBSTRUCTURE  
 END BENT #2**

NBL

REVISIONS				SHEET NO.			
NO.	BY:	DATE:	NO.	BY:	DATE:	S03-25	
1			3			TOTAL SHEETS	
2			4			30	

DRAWN BY : T.J. KIRSCHBAUM DATE : 08/28/14  
 CHECKED BY : E.E. DEETSCREEK DATE : 09/04/14  
 DESIGN ENGINEER OF RECORD : R.F. WERTMAN DATE : 09/05/14

PLANS PREPARED BY:  
**Gannett Fleming**  
 Excellence Delivered As Promised

1121 Situs Court  
 Suite 170  
 Raleigh, NC 27606-4279  
 (919) 859-4880  
 NCLic. No. F-0270

