

PLAN

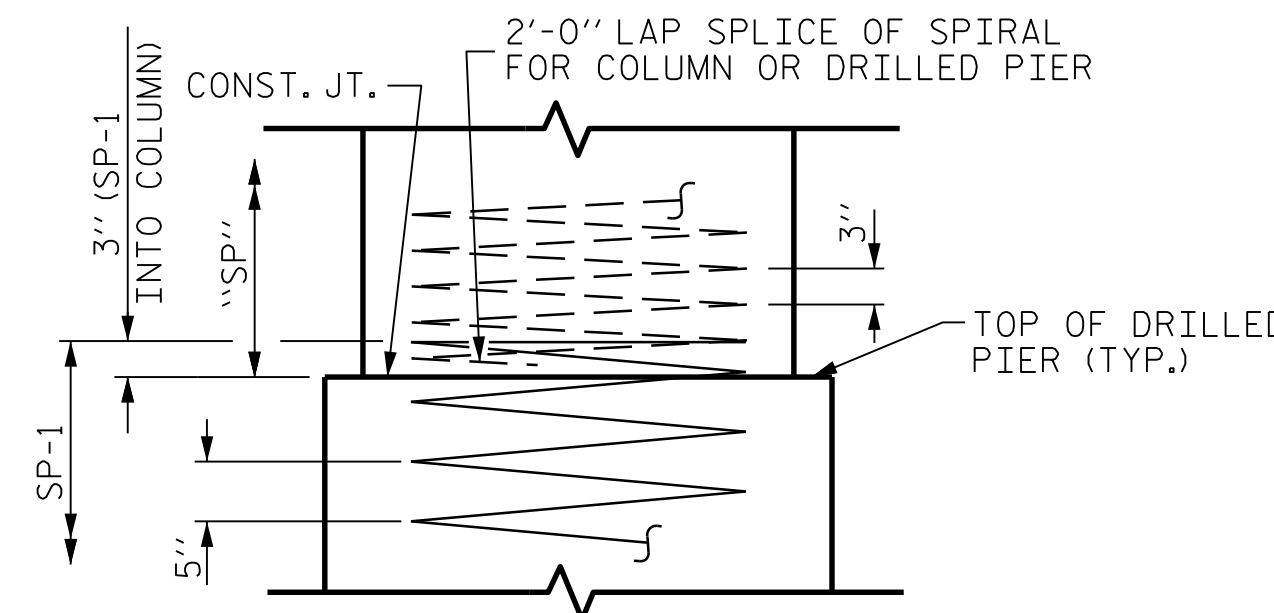

CONSTRUCTION JOINT DETAIL

NOTES

FOR SECTION A-A, VIEW X-X, AND VIEW Y-Y, SEE SHEET 2 OF 2.

STIRRUPS AND U1 BARS IN THE CAP MAY BE SHIFTED AS NECESSARY TO CLEAR ANCHOR BOLTS.

THE CONTRACTOR'S ATTENTION IS CALLED TO THE FACT THAT THE LONGITUDINAL REINFORCEMENT FOR THE DRILLED PIERS IS DETAILED WITH 3 FEET OF EXTRA LENGTH.

ALL STEEL IN THE DRILLED PIERS IS INCLUDED IN THE PAY ITEMS FOR "REINFORCING STEEL" AND "SPIRAL COLUMN REINFORCING STEEL."

SPLICING OF LONGITUDINAL BARS IN THE DRILLED PIER WILL NOT BE PERMITTED.

HOOKS ON "V" BARS MAY BE TURNED AS NECESSARY FOR PLACING REINFORCING STEEL.

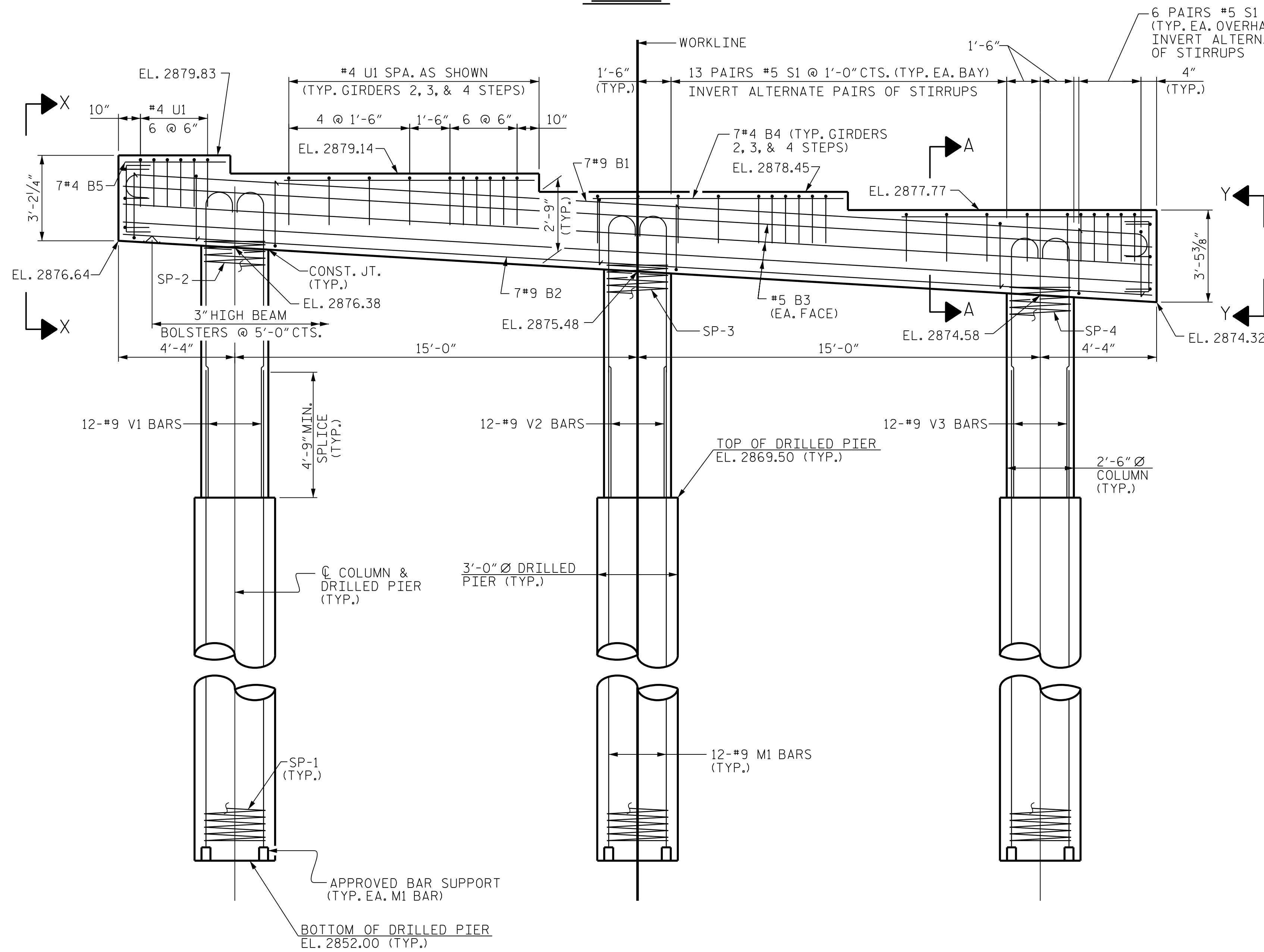

ELEVATION

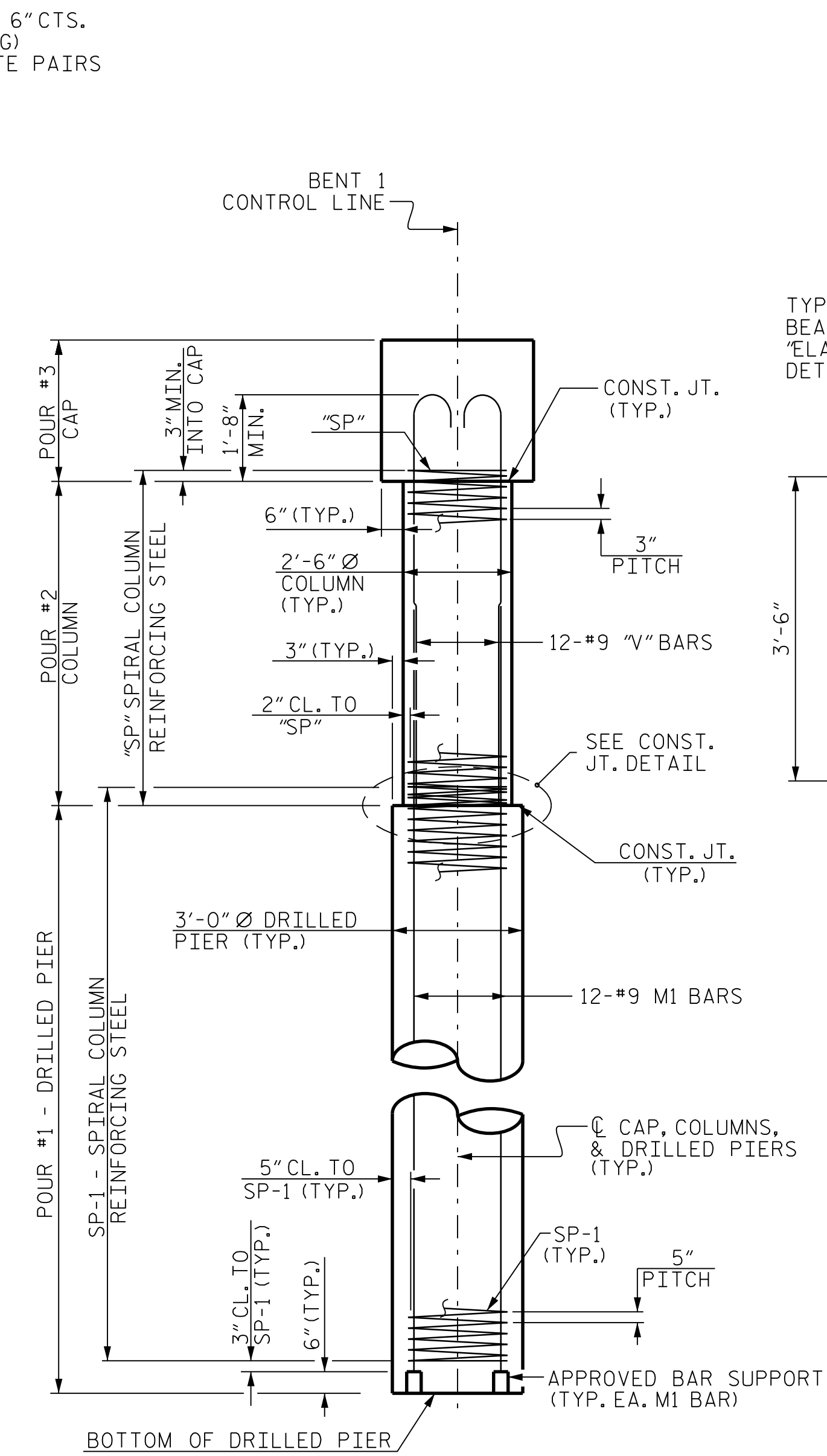

END ELEVATION

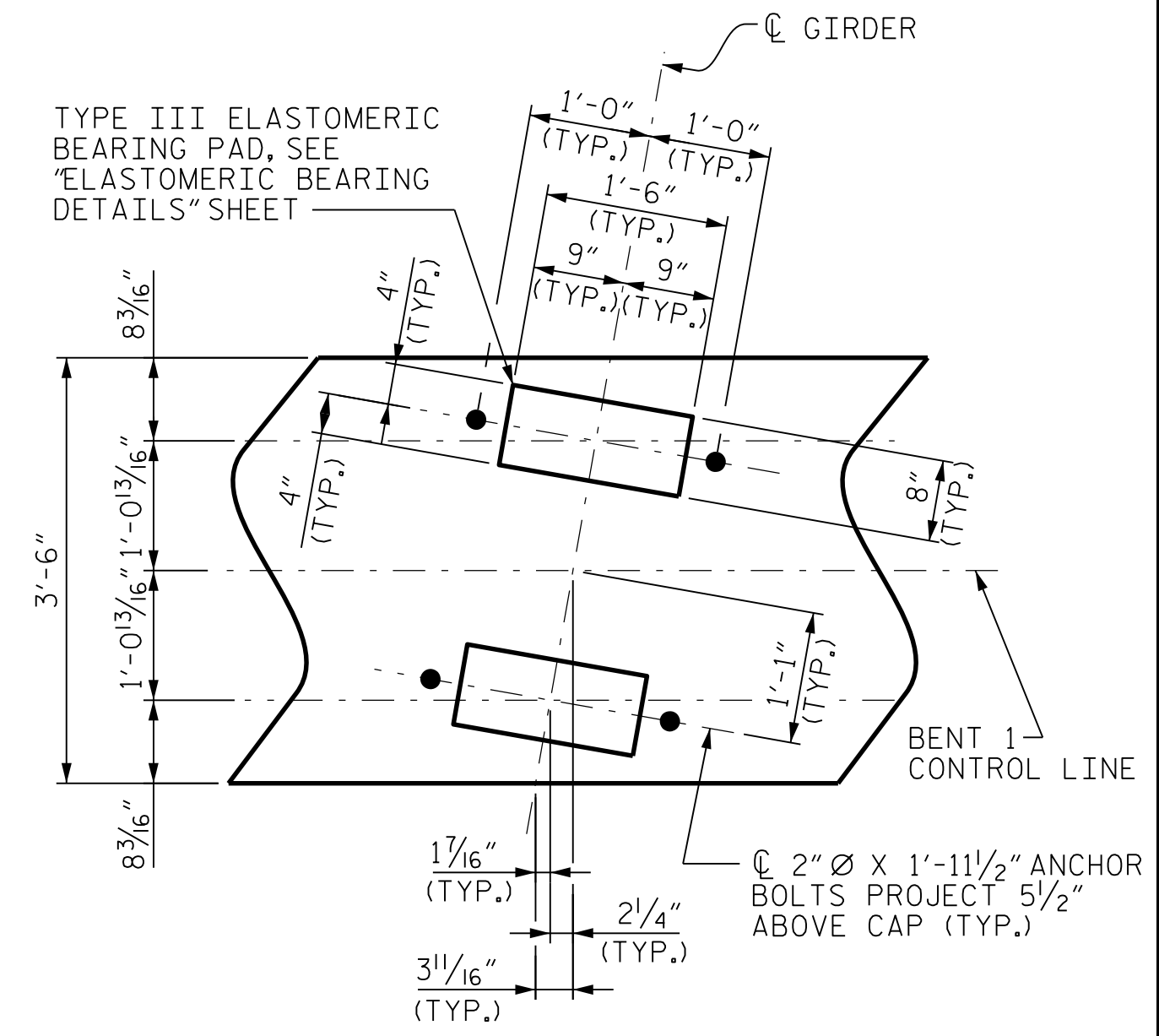

DETAIL "A"

(TYP. EACH GIRDER)

PROJECT NO. R-2915B
 ASHE COUNTY
 STATION: 198+64.50 -L-

SHEET 1 OF 2

STATE OF NORTH CAROLINA
 DEPARTMENT OF TRANSPORTATION
 RALEIGH

SUBSTRUCTURE
 BENT 1
 (NBL)



CDM Smith
 CDM SMITH
 5400 Glenwood Avenue, Suite 400
 Raleigh, NC 27612-3228
 NC COA No. F-1255

DRAWN BY : B. WADSWORTH DATE : 06-15 DWG. No.
 CHECKED BY : J. TAYLOR DATE : 06-15
 DESIGN ENGINEER : J. TAYLOR DATE : 06-15

REVISIONS		SHEET No.			
No.	BY:	DATE:	No.	BY:	DATE:
1			3		
2			4		

TOTAL SHEETS 34

FILE: R:\med\192915B Structures\PLANS\Bent 1.dgn
 DATE: 8/10/2015 7:04:23 AM