

DRAINAGE DETAILS

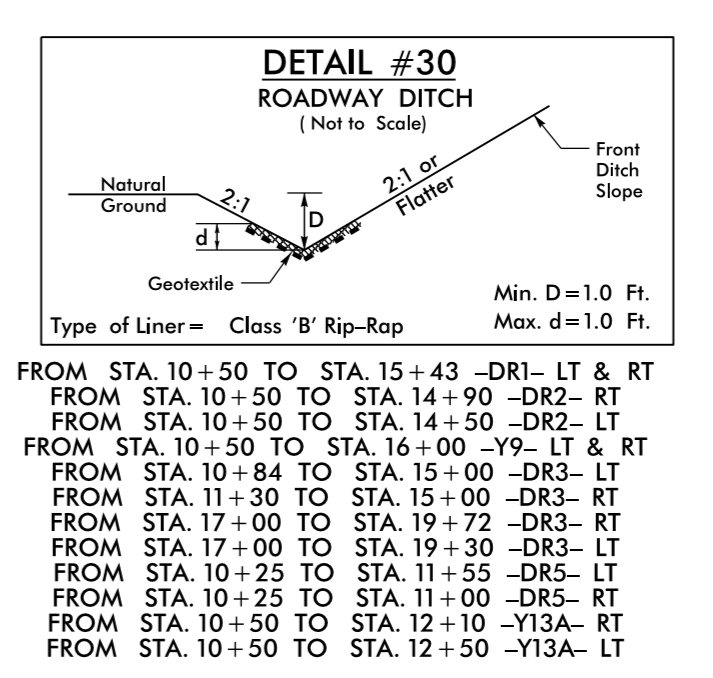
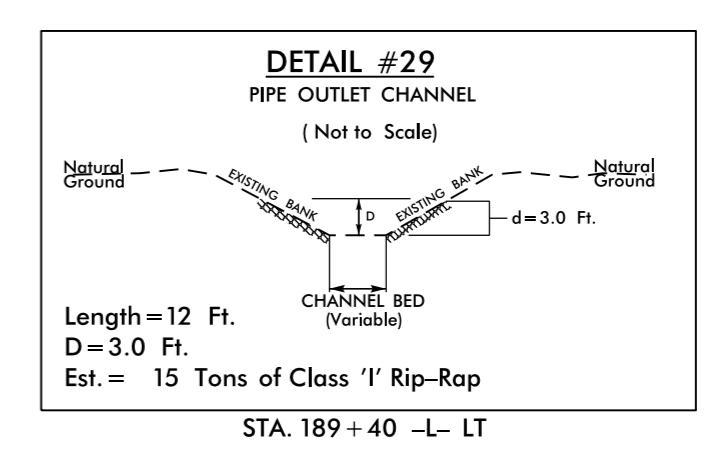
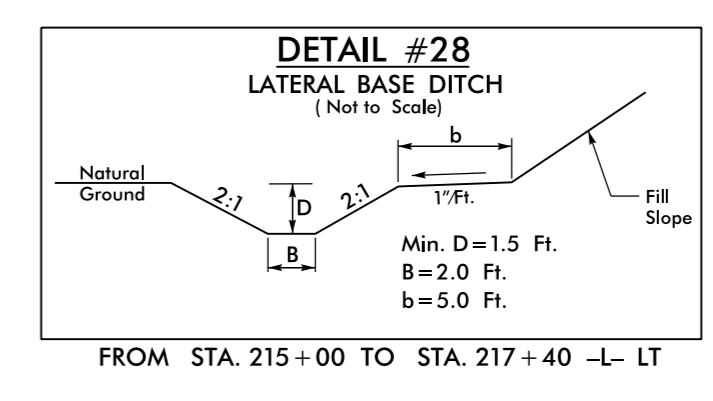
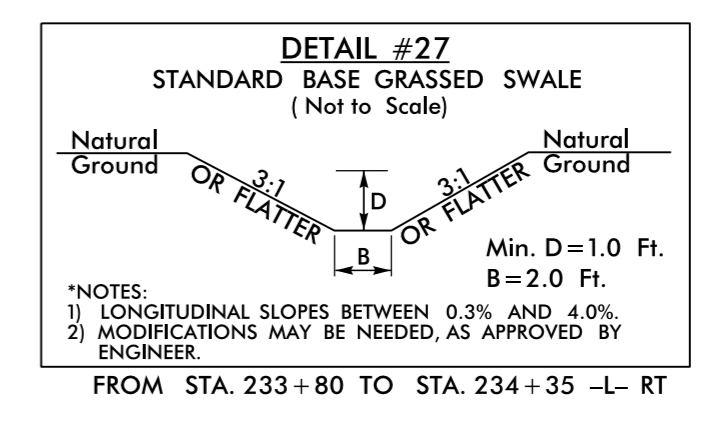
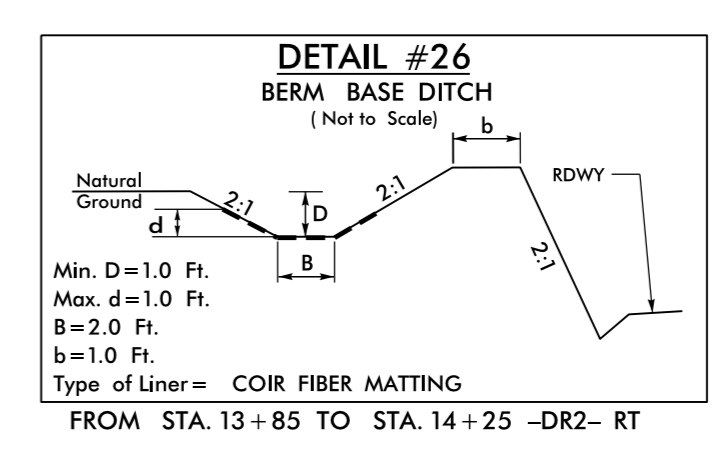
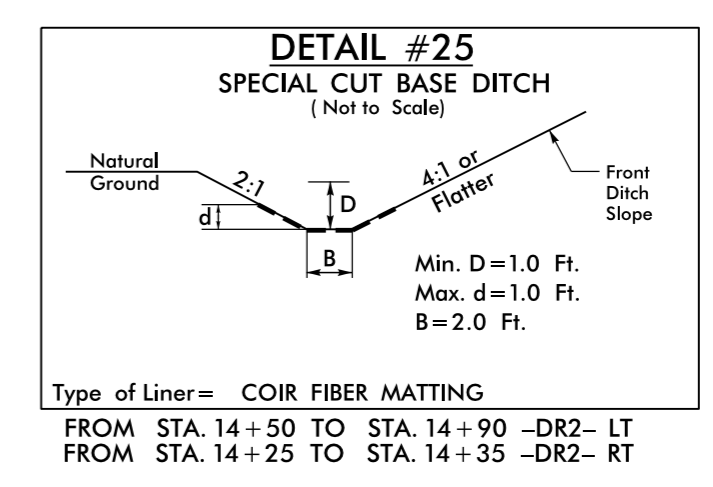
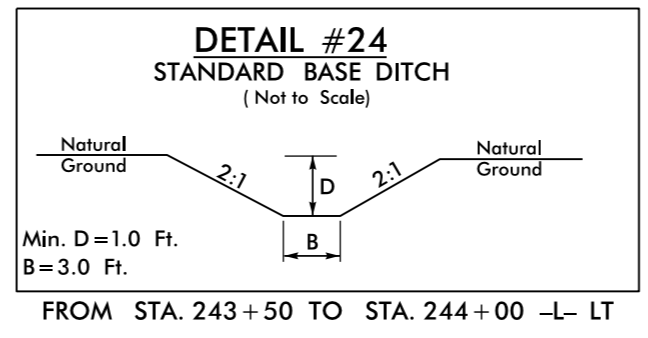
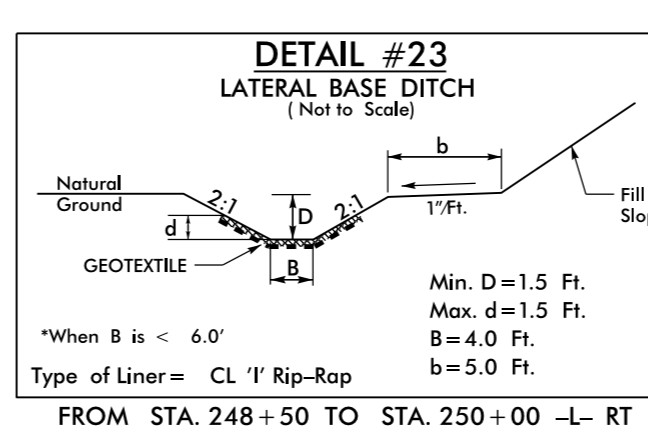
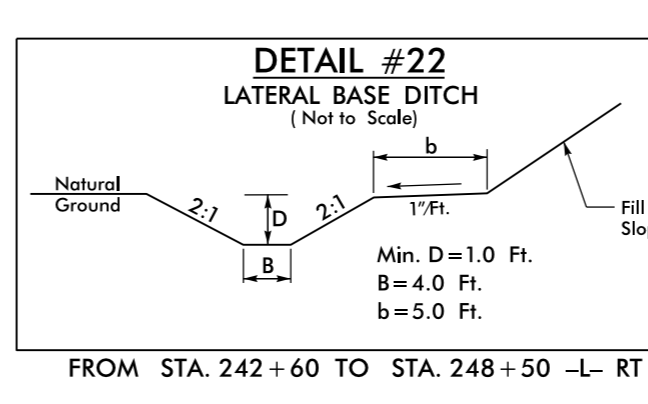
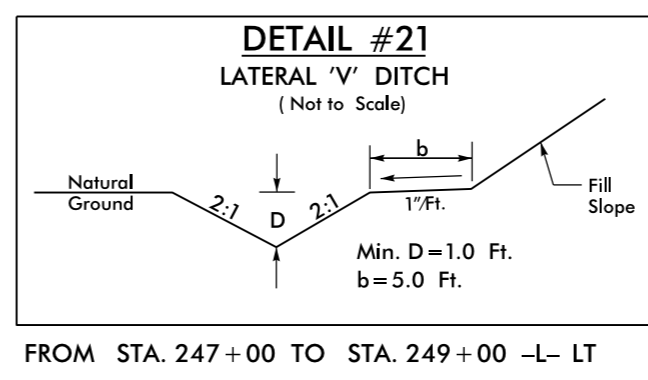
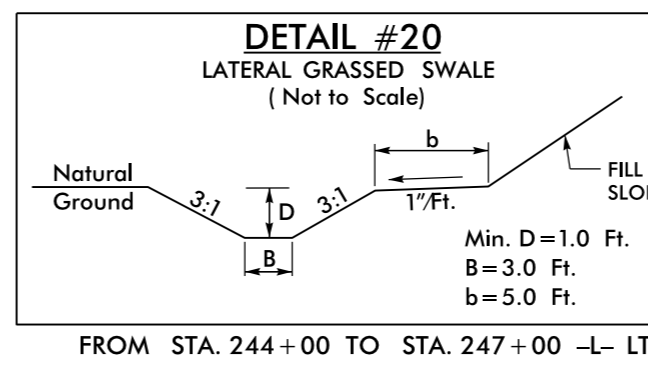
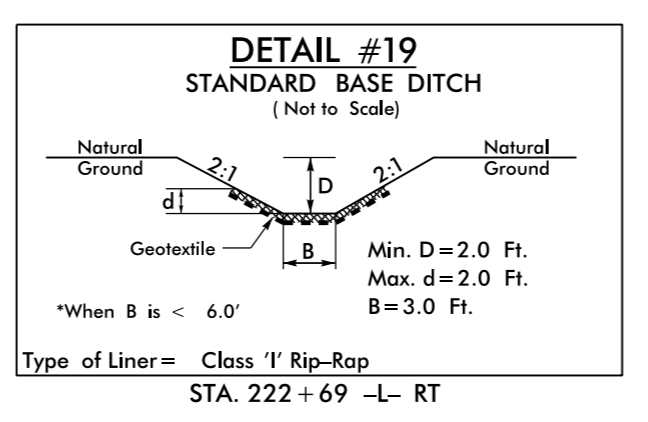
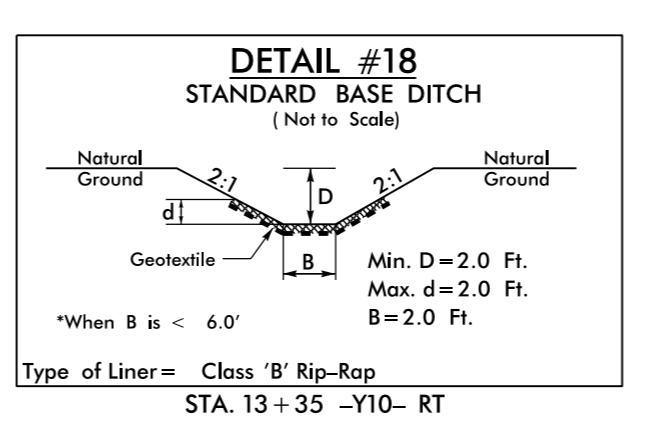
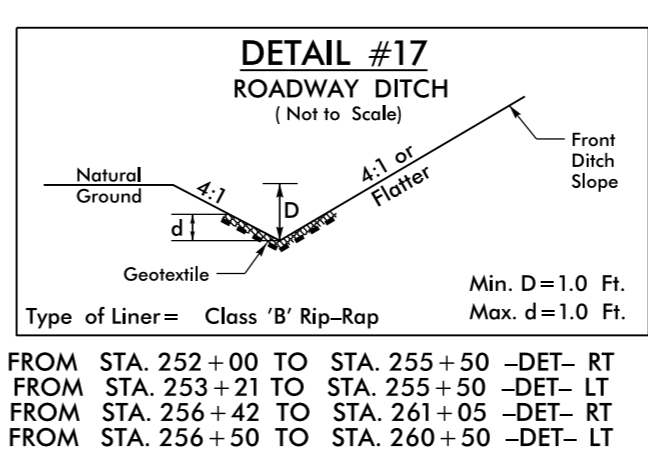
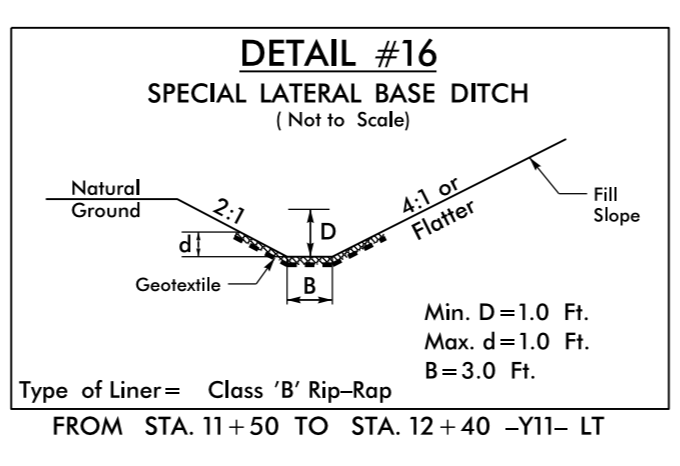
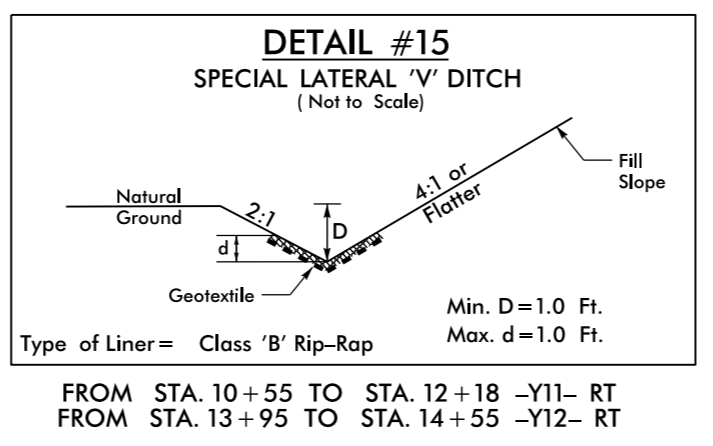
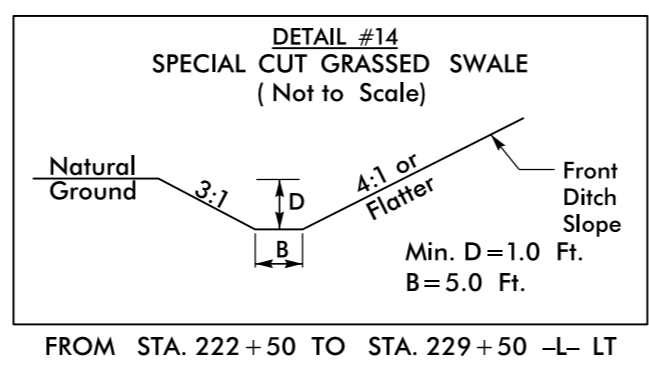
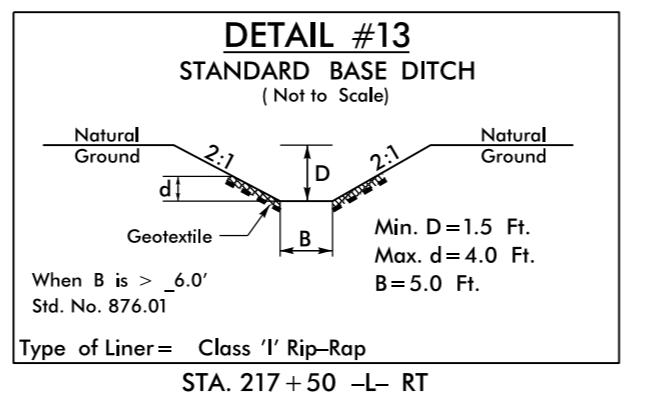
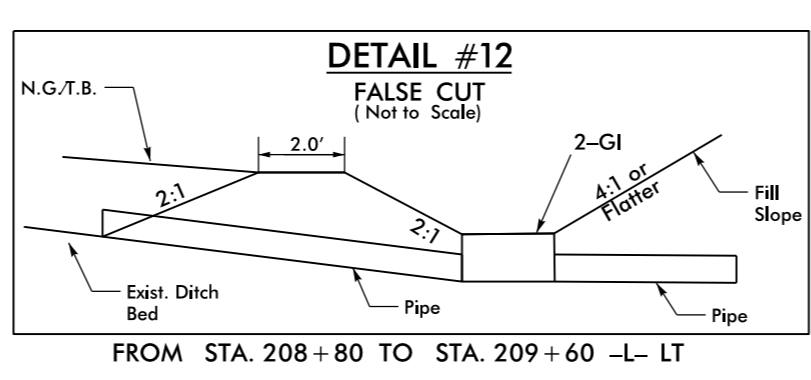
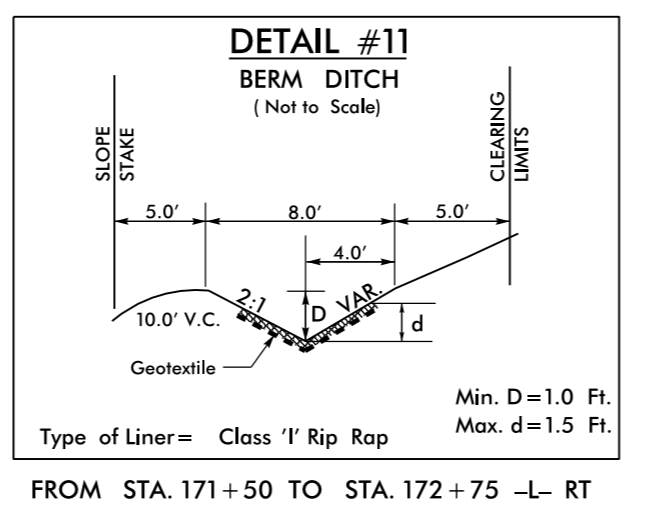
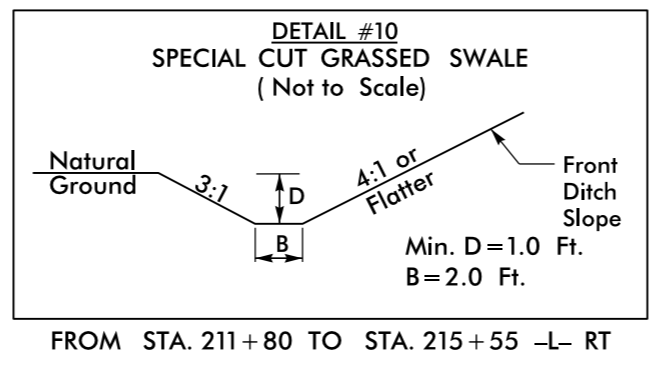
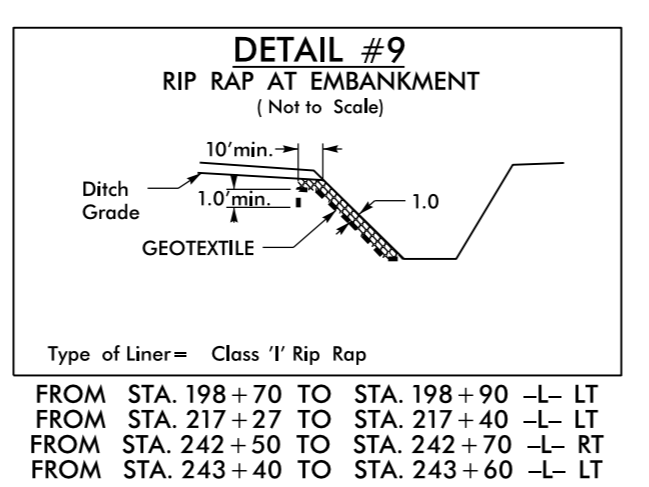
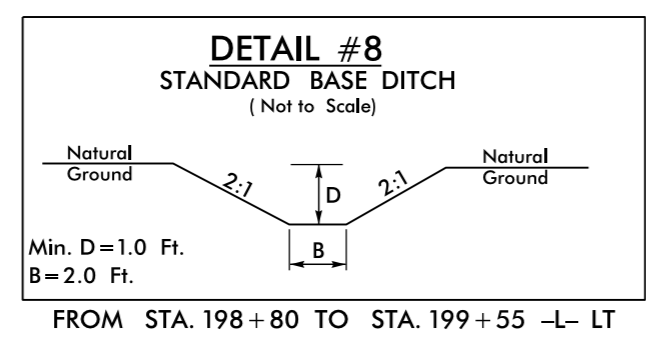
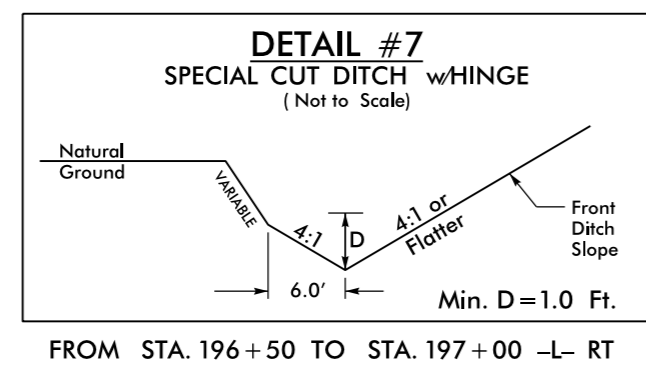
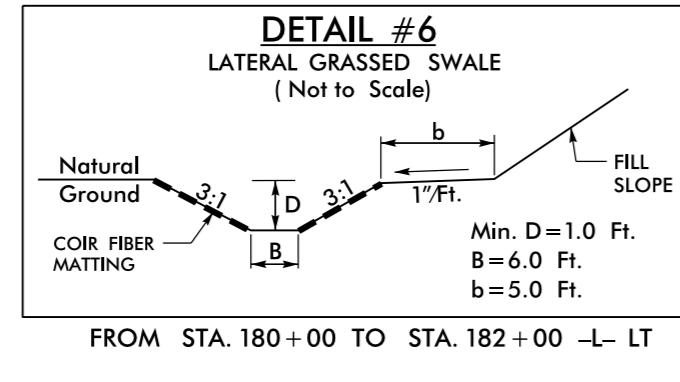
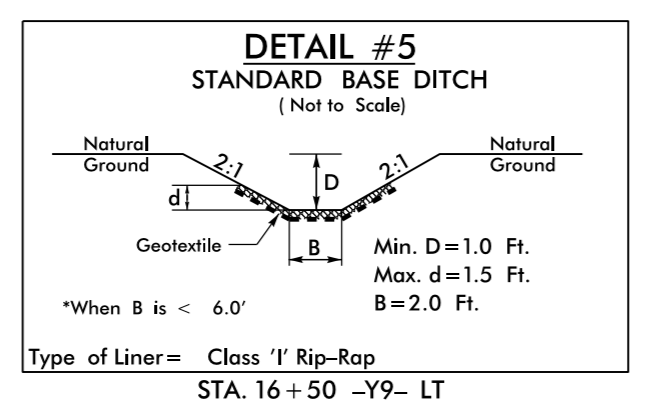
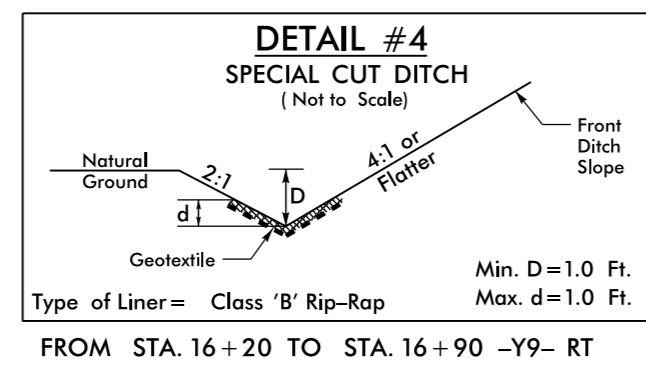
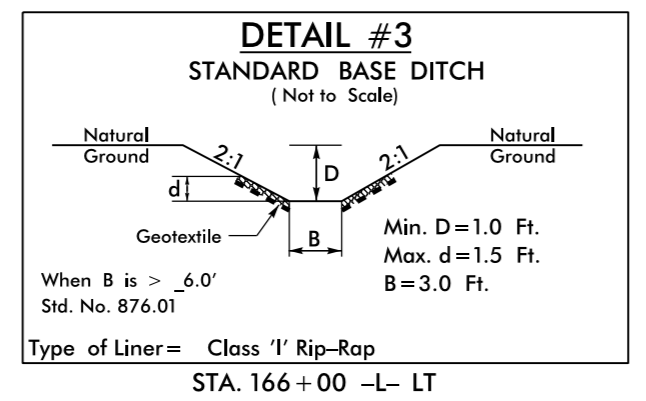
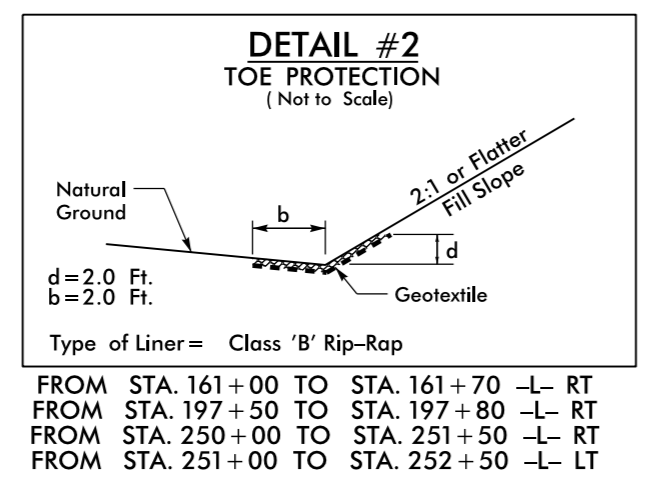
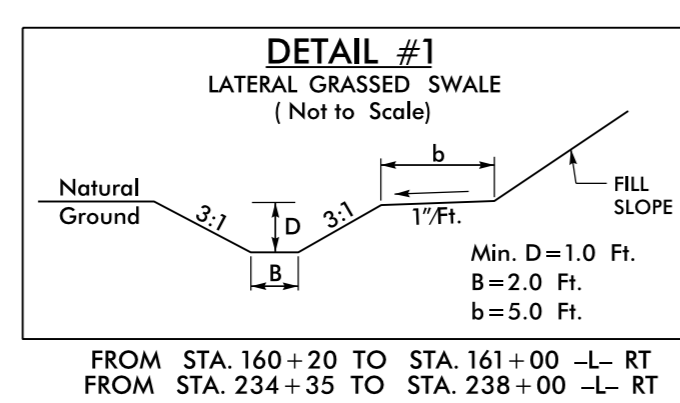

5/14/99

6/26/2015 2:03:22 PM
USER:R-2915B-hyd-DETAILS.dgn