

PLAN

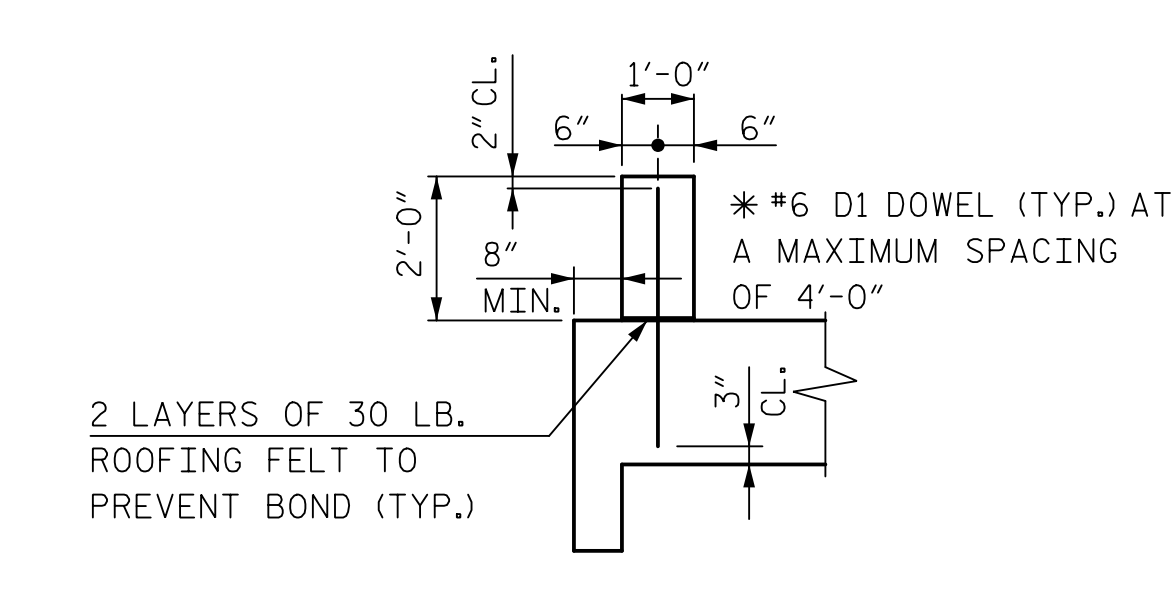

*DOWELS MAY BE PUSHED INTO GREEN CONCRETE AFTER SLAB HAS BEEN FLOAT FINISHED.

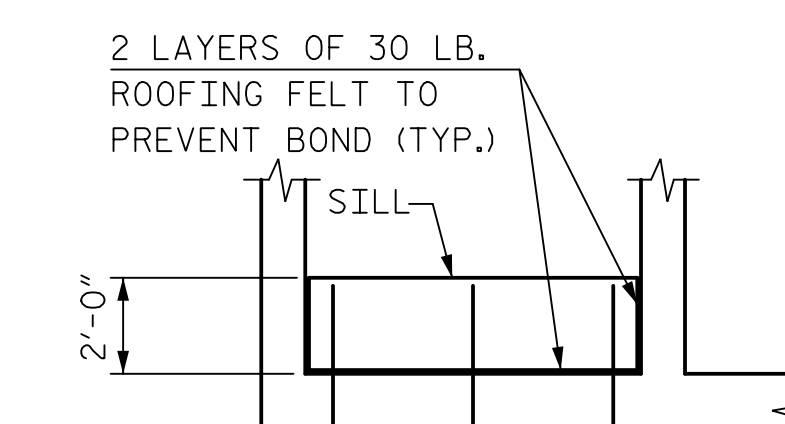

ELEVATION

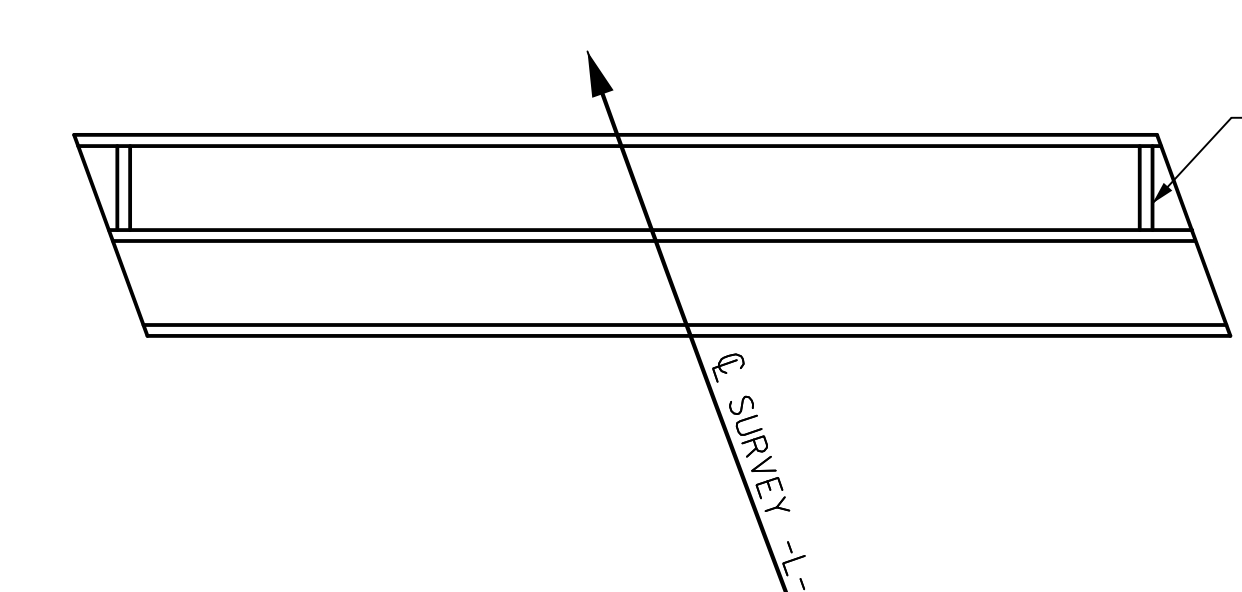

SILL LAYOUT PLAN

DocuSigned by:
Paul J. Barber
License No. C-1554
343 E. Six Forks Rd., Suite 200, Raleigh, N.C. 27609
2/27/2015

DocuSigned by:
David W. Hawkins
License No. C-1554
343 E. Six Forks Rd., Suite 200, Raleigh, N.C. 27609
2/27/2015

SEAL 12916
ENGINEER
PAUL J. BARBER
2/27/2015

SEAL 27812
ENGINEER
DAVID W. HAWKINS
2/27/2015

PROJECT NO. P-4900A
ROBESON COUNTY
 STATION: POC 55+31.95 -L-
 MILE POST: 0.86
 SHEET 2 OF 6

STATE OF NORTH CAROLINA
 DEPARTMENT OF TRANSPORTATION
 RALEIGH

PLAN
 DOUBLE 7 FT. x 6 FT.
 CONCRETE BOX CULVERT
 AT POC STA. 55+31.95 -L-

REVISIONS						SHEET NO.
NO.	BY:	DATE:	NO.	BY:	DATE:	C-2
1	J. BAYNE	7/14	3			TOTAL SHEETS
2	P. BARBER	8/14	4			6

DRAWN BY: J. BAYNE DATE: 7/14
 CHECKED BY: P. BARBER DATE: 8/14
 DWG. NO. 2