

# Welded Ring Stiffened Mast Arm Connection

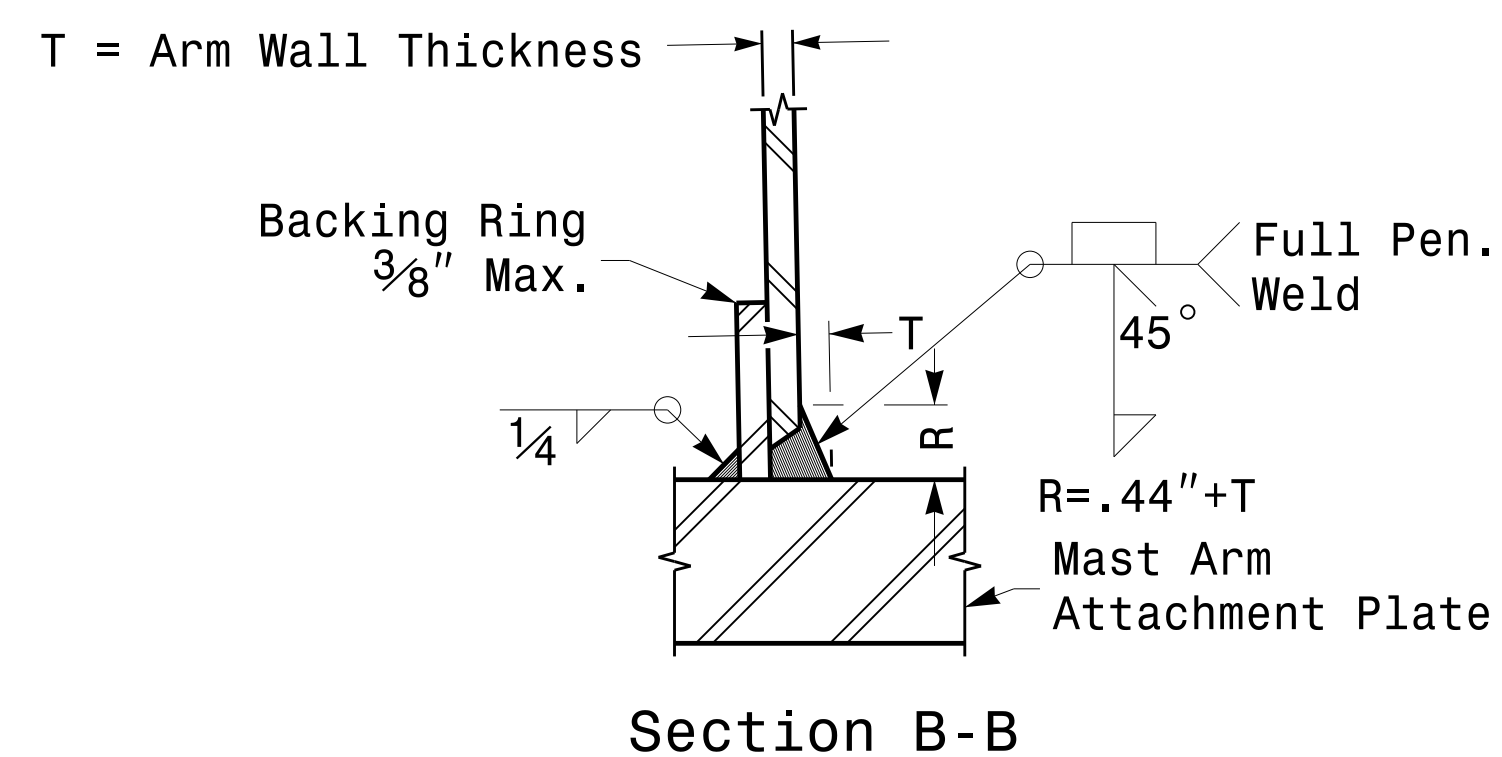
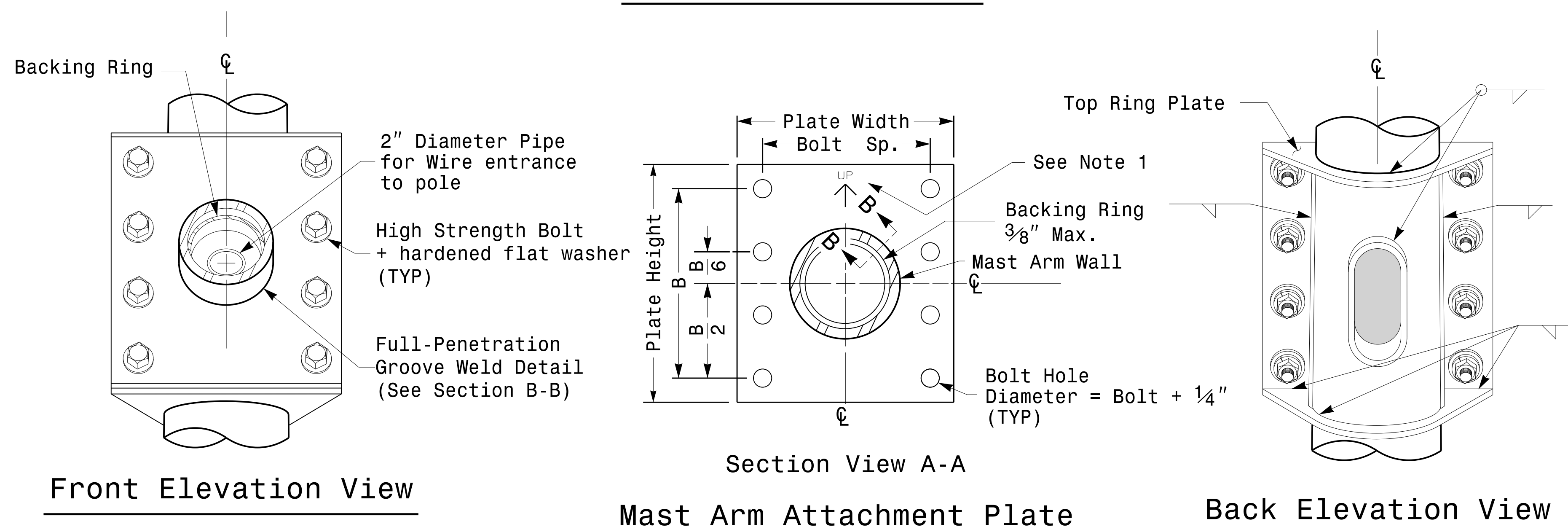
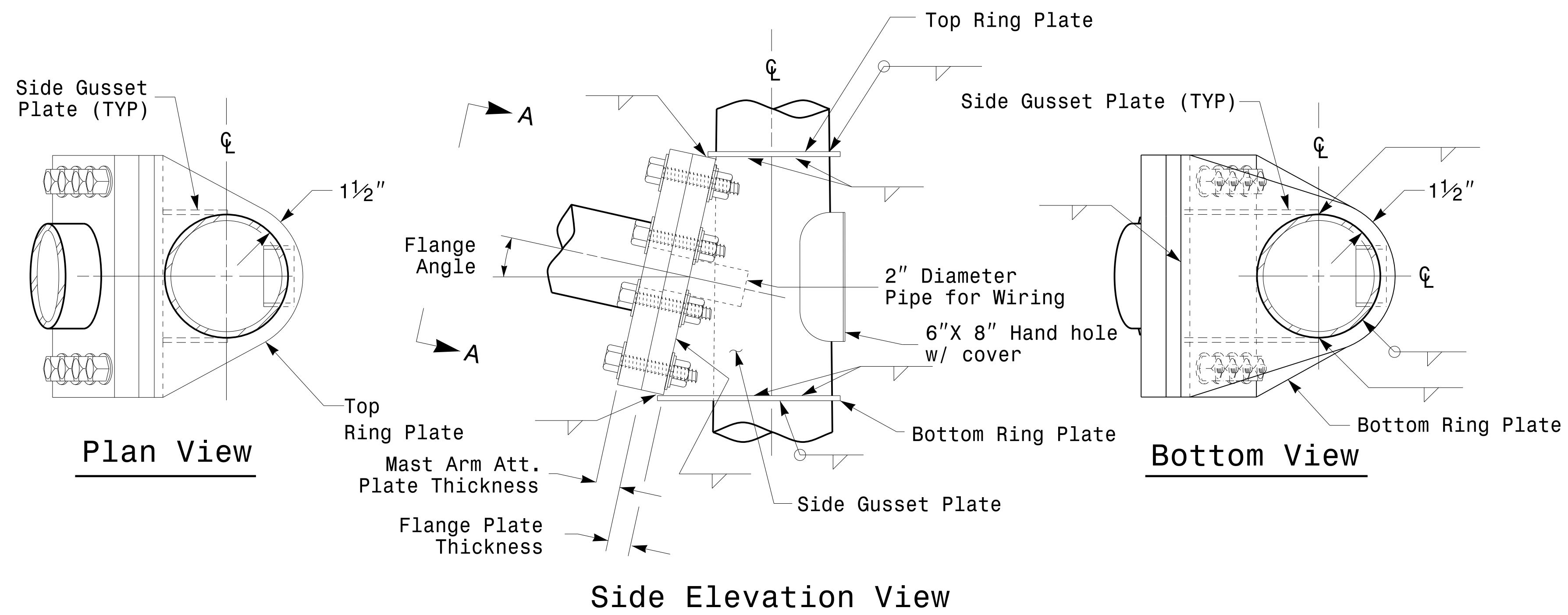

Section B-B  
Full-Penetration Groove Weld Detail

Notes:

1. Provide a permanent means of identification above the mast arm to indicate proper attachment orientation of the mast arm.
2. Designer will determine the size of all structural components, plates, fasteners, and welds shown unless they are already specified.
3. Designer is responsible for providing appropriate drainage points.

	Fabrication Details For Mast Arm Connection To Pole		
	PLAN DATE: AUGUST 2013 PREPARED BY: N. BITTING	DESIGNED BY: C.F. ANDREWS REVIEWED BY: D.C. SARKAR	
SCALE: 0 NA NONE		DocuSign by: D. C. Sarkar 8/26/2014 44EBE32E147E4C4 DATE SIG. INVENTORY NO.	

06-10-2014 08:47  
 S:\Projects\2013\Signal Design\Section\Eastern Region\MM Sheets\2012\_M5\_Fab\_Details\MastArms.dgn  
 Topiloway

Fabrication Details – Mast Arm Poles