

# Welded Ring Stiffened Mast Arm Connection

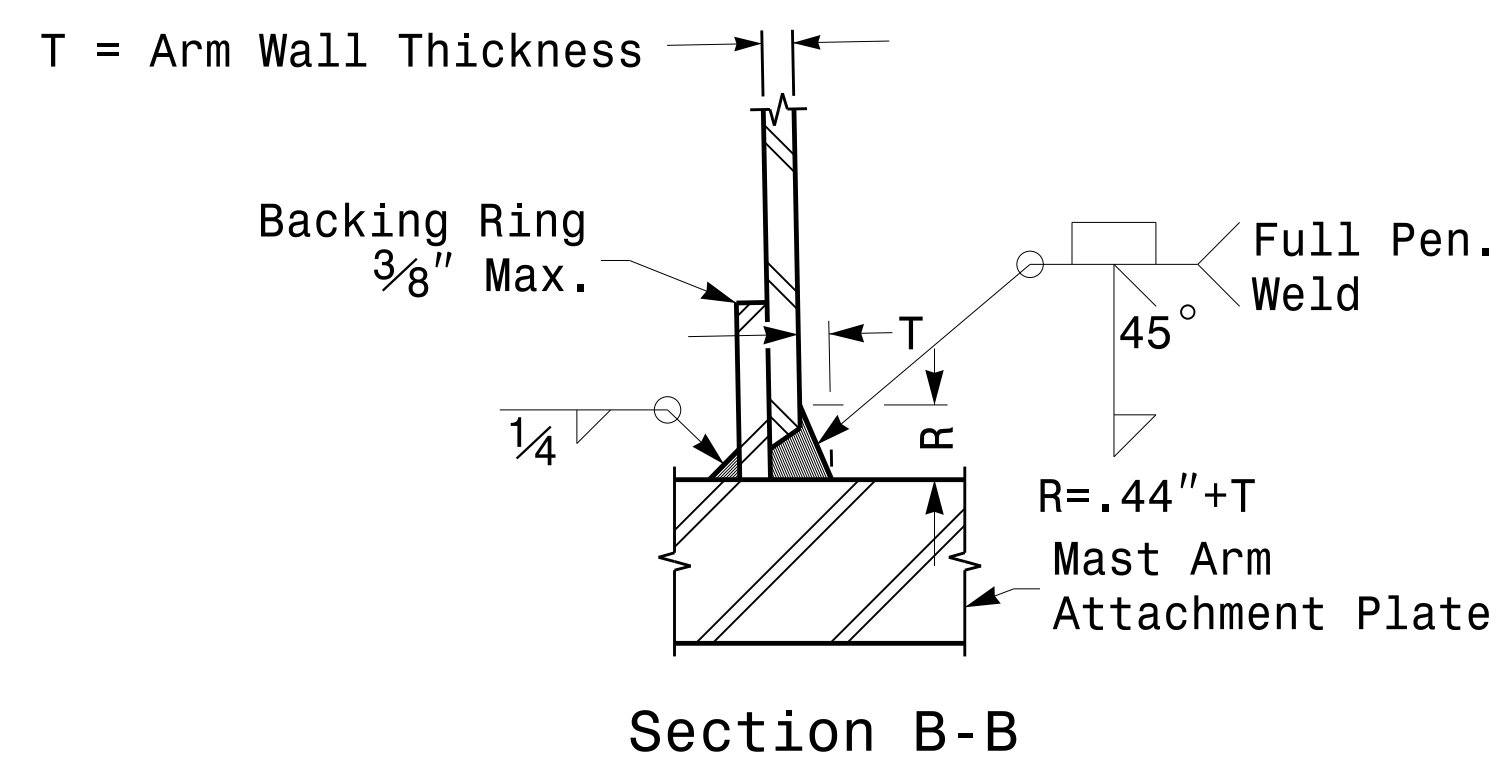
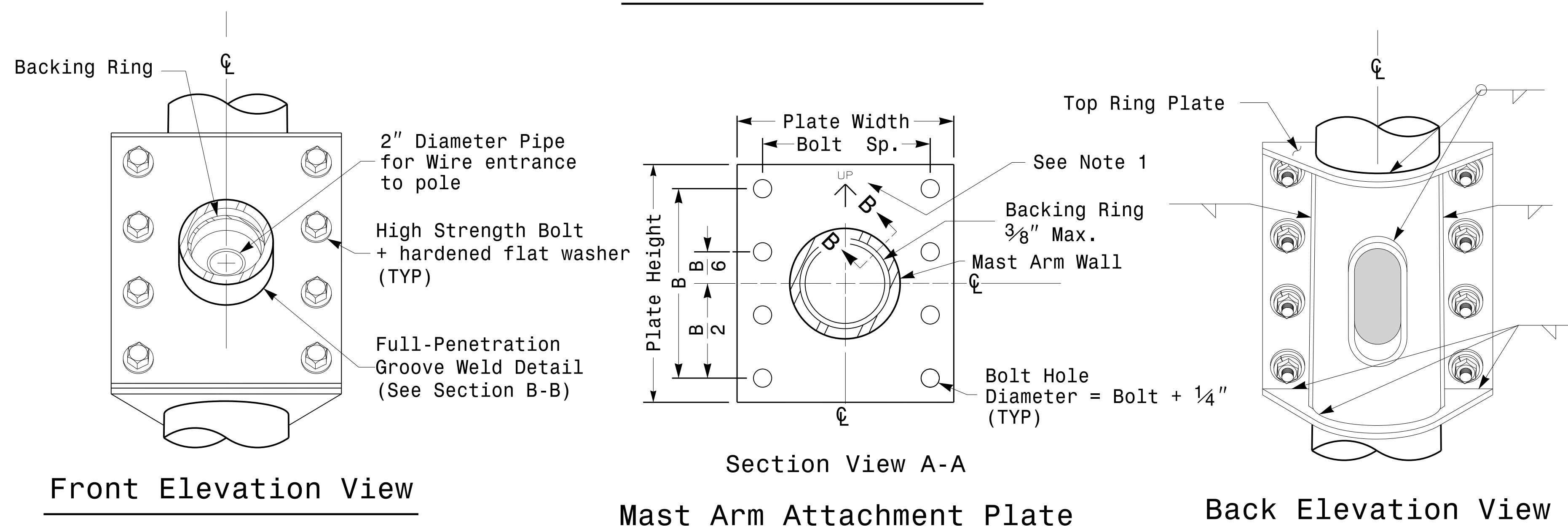
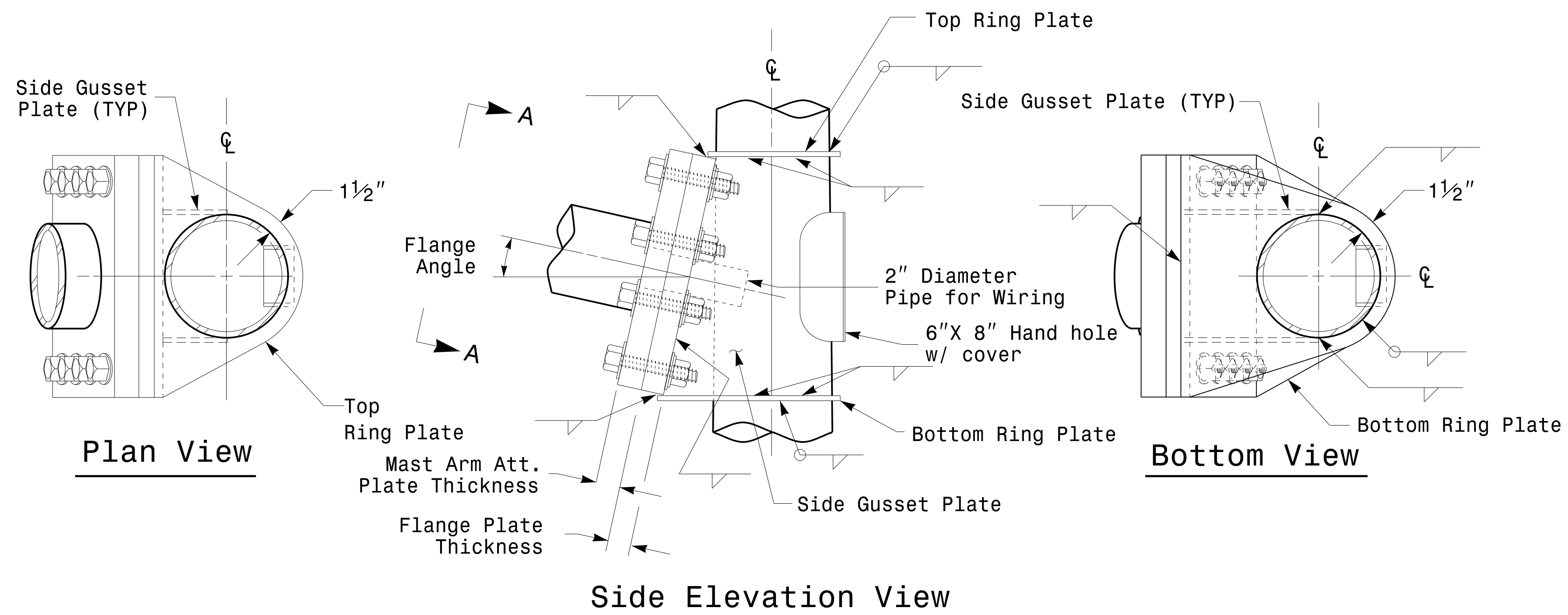

**Full-Penetration Groove Weld Detail**

**Notes:**

1. Provide a permanent means of identification above the mast arm to indicate proper attachment orientation of the mast arm.
2. Designer will determine the size of all structural components, plates, fasteners, and welds shown unless they are already specified.
3. Designer is responsible for providing appropriate drainage points.

	<p align="center"><b>Fabrication Details For Mast Arm Connection To Pole</b></p>		
	<p>PLAN DATE: AUGUST 2013</p>	<p>DESIGNED BY: C.F. ANDREWS</p>	
<p>750 N. Greenfield Pkwy, Garner, NC 27529</p>	<p>PREPARED BY: N. BITTING</p>	<p>REVIEWED BY: D.C. SARKAR</p>	<p>INIT. DATE</p>
<p>SCALE: 0 NA NONE</p>	<p>DocuSign by: D. C. Sarkar</p>	<p>8/26/2014</p>	<p>SIG. INVENTORY NO.</p>

06-10-2014 08:47  
 S:\Projects\2013\Signal\Signal Design\Section\Eastern Region\MM Sheets\2012\_M5\_Fab\_Details\MastArms.dgn  
 Topiloway

**Fabrication Details – Mast Arm Poles**