

| PI Sta                       | PI Sta                        | PI Sta                        | PI Sta                        |
|------------------------------|-------------------------------|-------------------------------|-------------------------------|
| 26+76.04                     | 28+69.86                      | 31+31.38                      | 37+81.34                      |
| $\Delta = 7' 01" 50.8" (LT)$ | $\Delta = 33' 16" 08.6" (RT)$ | $\Delta = 25' 34" 24.5" (LT)$ | $\Delta = 30' 47" 42.5" (LT)$ |
| $D = 3' 48" 23.2"$           | $D = 16' 51" 06.1"$           | $D = 7' 50" 55.5"$            | $D = 12' 43" 56.6"$           |
| $L = 184.71'$                | $L = 197.42'$                 | $L = 325.83'$                 | $L = 241.86'$                 |
| $T = 92.47'$                 | $T = 101.58'$                 | $T = 165.67'$                 | $T = 123.93'$                 |
| $R = 1,505.23'$              | $R = 340.00'$                 | $R = 730.00'$                 | $R = 450.00'$                 |
| $SE = 0.034$                 | $SE = 0.05$                   | $SE = 0.05$                   | $SE = 0.05$                   |
| <b>RUNOFF 68'</b>            | <b>RUNOFF 100'</b>            | <b>RUNOFF 100'</b>            | <b>RUNOFF 118'</b>            |

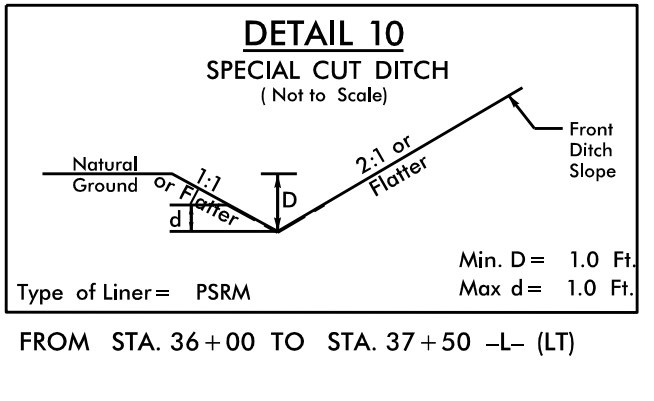

Z CLAIM DETAILS FOR PARCELS 13, 17, AND 22

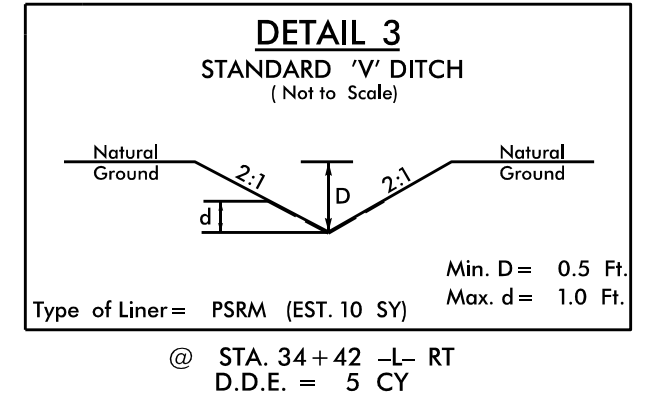
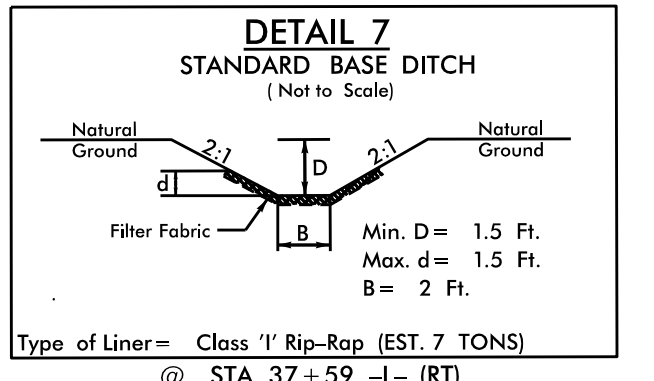
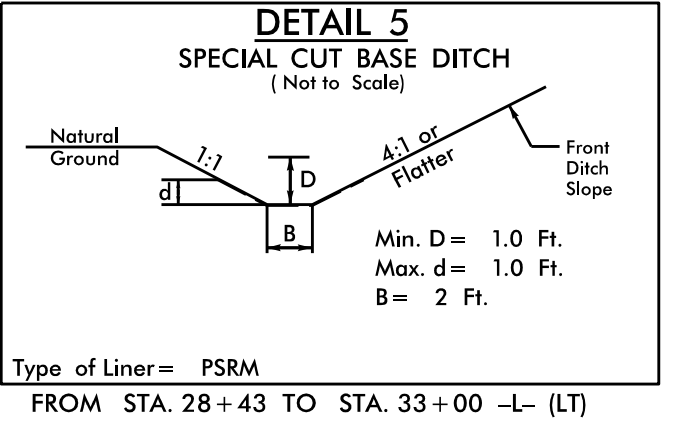
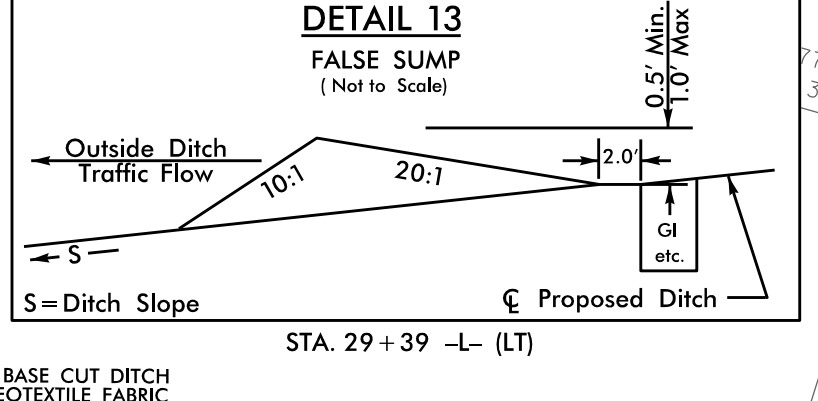
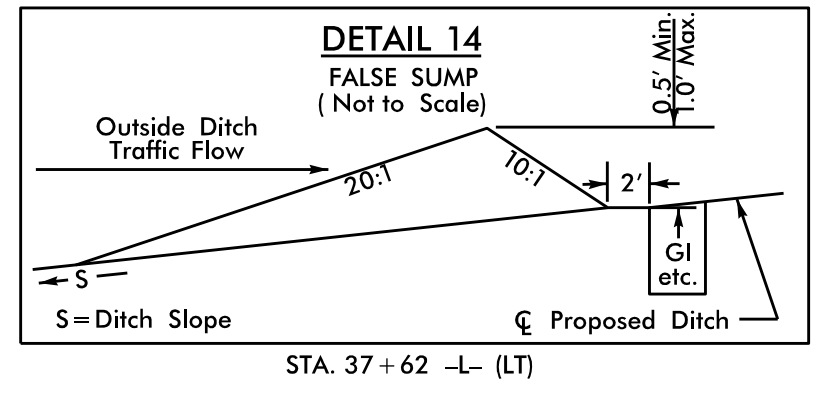
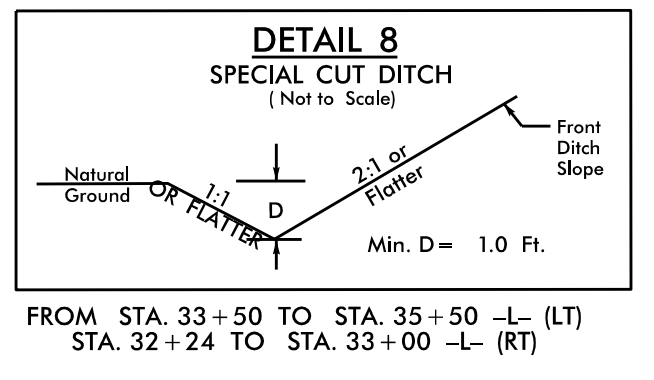
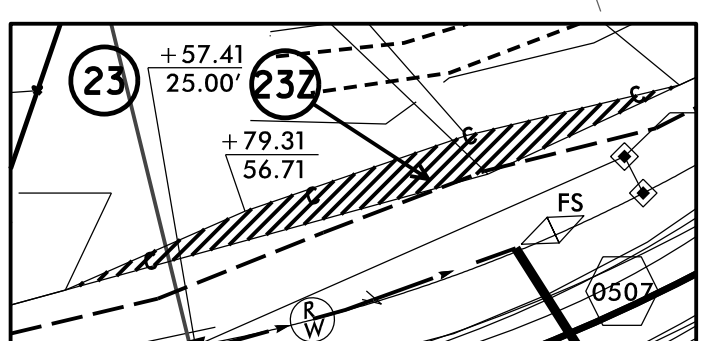
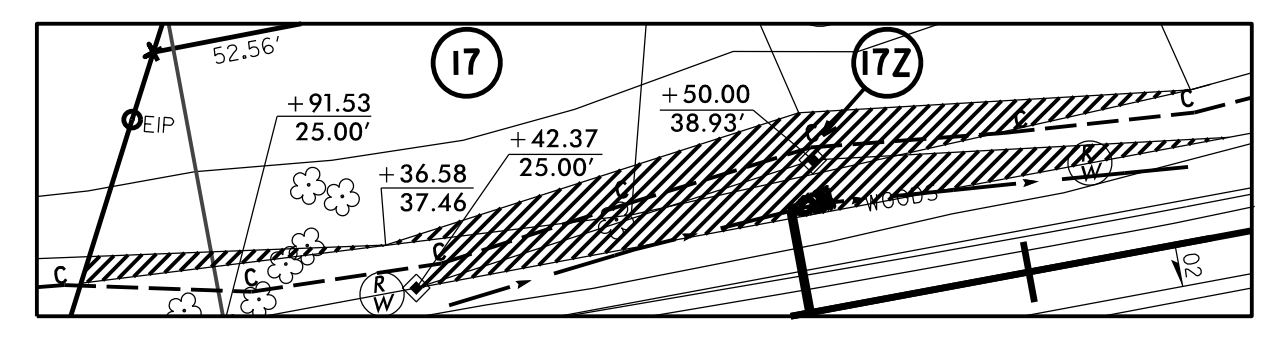
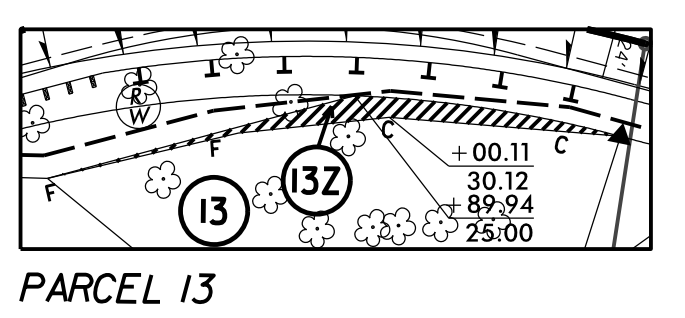
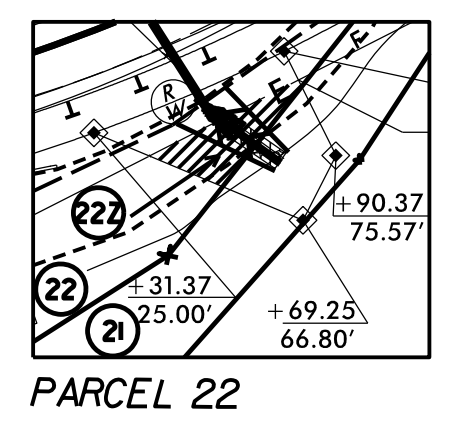

PARCEL 17

PARCEL 23

RADIi AT DRIVEWAYS ARE 10' UNLESS SHOWN OTHERWISE

NOTE: SEE PLAN SHEET 9 & 10 FOR -L- PROFILE