

MATCHLINE -L- STA. 53+50 SEE SHEET 6

MATCHLINE -L- STA. 67+00 SEE SHEET 8

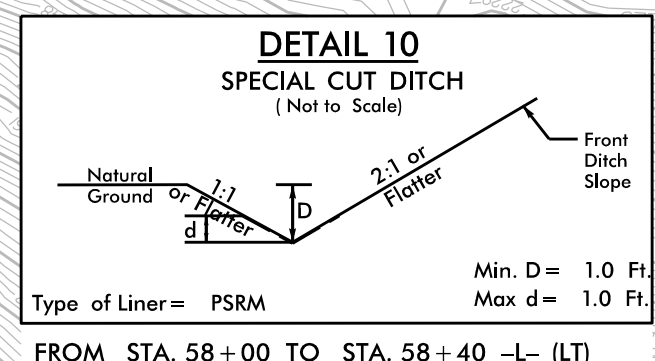

**NOTE:**  
ALL PERIMETER EROSION CONTROL MEASURES AND ROCK PIPE INLET SEDIMENT TRAPS TYPE B & TEMPORARY ROCK SILT CHECKS TYPE A AT EXISTING CULVERTS SHALL BE INSTALLED PRIOR TO ANY GRUBBING OPERATIONS WITHIN PROJECT LIMITS.

**NOTE:**  
PLACE TEMPORARY ROCK SEDIMENT DAMS TYPE - B AND TEMPORARY ROCK SILT CHECKS TYPE - A AT DRAINAGE OUTLETS.

**NOTE:**  
NO EROSION CONTROL DEVICES SHALL BE PLACED IN EXISTING DITCH LINES WITH LESS THAN 1'-0" DEPTH IF EXISTING ROAD IS TO REMAIN IN SERVICE DURING CONSTRUCTION ACTIVITIES.

CLEARING AND GRUBBING EROSION CONTROL FOR CONSTRUCTION SHEET 7

Z CLAIM DETAILS FOR PARCELS 39, 45 AND 48

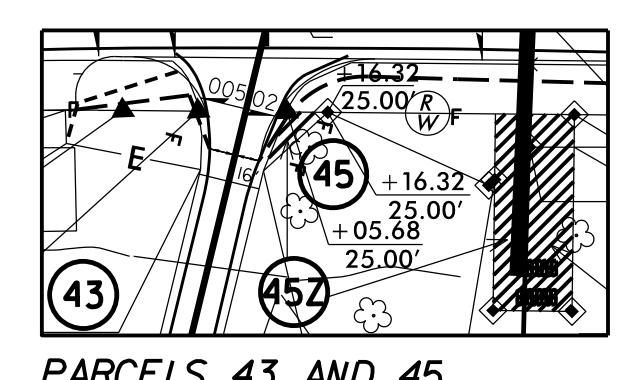

PARCELS 43 AND 45

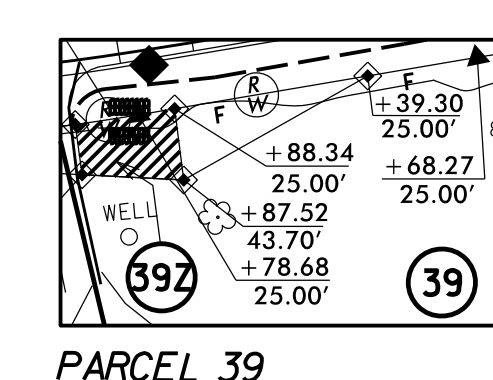

PARCEL 39

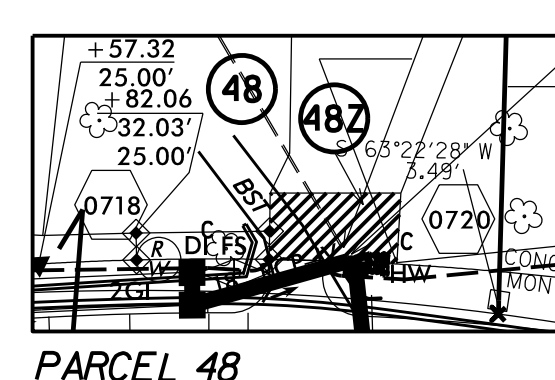

PARCEL 48

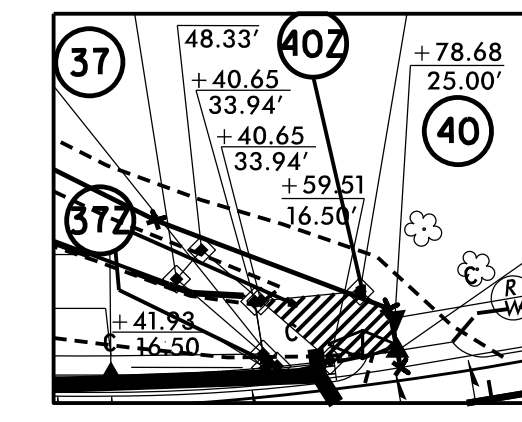

PARCELS 37 AND 40

RADI AT DRIVEWAYS ARE 10' UNLESS SHOWN OTHERWISE

NOTE: SEE PLAN SHEET 10 FOR -L- PROFILE