

**This electronic collection of documents is provided
for the convenience of the user
and is Not a Certified Document –**

**The documents contained herein were originally issued
and sealed by the individuals whose names and license
numbers appear on each page, on the dates appearing
with their signature on that page.**

**This file or an individual page
shall not be considered a certified document.**

T.I.P.: R-2514B&C

CONTRACT:

**STATE OF NORTH CAROLINA
DEPARTMENT OF TRANSPORTATION**

**PAVEMENT MARKING PLAN
ON SLOW & JONES COUNTIES**

**LOCATION: US 17 FROM SOUTH OF BELGRADE AT SR 1330 /SR 1439
TO SOUTH OF NC 58 NEAR POLLOCKSVILLE**

<small>TIP NO.</small> R-2514B&C	<small>SHEET NO.</small> PMP-1
<small>APPROVED:</small> <u>Rhonda B. Early</u> <small>DocuSigned by: F34CAFAC8BF48A...</small>	
<small>DATE:</small> 2/10/2015	
	

ROADWAY STANDARD DRAWINGS

THE FOLLOWING ROADWAY STANDARDS AS APPEAR IN "ROADWAY STANDARD DRAWINGS" - PROJECT SERVICES UNIT - N.C. DEPARTMENT OF TRANSPORTATION - RALEIGH, N.C., DATED JANUARY 2012 ARE APPLICABLE TO THIS PROJECT AND BY REFERENCE HEREBY ARE CONSIDERED A PART OF THESE PLANS:

<u>STD. NO.</u>	<u>TITLE</u>
1205.01	PAVEMENT MARKINGS - LINE TYPES AND OFFSETS
1205.02	PAVEMENT MARKINGS - 2 LANE AND MULTI LANE ROADWAYS
1205.04	PAVEMENT MARKINGS - INTERSECTIONS
1205.05	PAVEMENT MARKINGS - TURN LANES
1205.08	PAVEMENT MARKINGS - SYMBOLS AND WORD MESSAGES
1205.09	PAVEMENT MARKINGS - PAINTED ISLANDS
1205.12	PAVEMENT MARKINGS - BRIDGES
1250.01	RAISED PAVEMENT MARKERS - INSTALLATION SPACING
1251.01	RAISED PAVEMENT MARKERS - PERMANENT & TEMPORARY
1253.01	RAISED PAVEMENT MARKERS - SNOWPLOWABLE
1261.01	GUARDRAIL AND BARRIER DELINEATORS - INSTALLATION SPACING
1261.02	GUARDRAIL AND BARRIER DELINEATORS - TYPES & MOUNTING
1262.01	GUARDRAIL END DELINEATION

GENERAL NOTES

THE FOLLOWING GENERAL NOTES APPLY AT ALL TIMES FOR THE DURATION OF THE CONSTRUCTION PROJECT, EXCEPT WHEN OTHERWISE NOTED IN THE PLAN, OR DIRECTED BY THE ENGINEER.

- A) INSTALL PAVEMENT MARKINGS AND PAVEMENT MARKERS ON THE FINAL SURFACE AS FOLLOWS:
- | <u>ROAD NAME</u> | <u>MARKING</u> | <u>MARKER</u> |
|--------------------|--|---------------|
| -L- (US 17 BYPASS) | THERMOPLASTIC | SNOWPLOWABLE |
| ALL BRIDGES | POLYUREA W/ HIGHLY REFLECTIVE ELEMENTS | RAISED |
| -Y- LINES | THERMOPLASTIC | RAISED |
- B) REMOVE ALL RESIDUE AND SURFACE LAITANCE BY WATER BLASTING OR GRINDING ON BRIDGE DECK(S) PRIOR TO PLACING POLYUREA PAVEMENT MARKINGS.
- C) TIE PROPOSED PAVEMENT MARKING LINES TO EXISTING PAVEMENT MARKING LINES.
- D) REMOVE/REPLACE ANY CONFLICTING/DAMAGED PAVEMENT MARKINGS AND MARKERS THAT HAVE BEEN DAMAGED BY THE END OF EACH DAY'S OPERATION.
- E) PASSING ZONE(S) WILL BE DETERMINED IN THE FIELD AND MUST BE APPROVED BY THE ENGINEER.
- F) MARKERS SHALL BE INSTALLED ACCORDING TO THE NCDOT ROADWAY STANDARD DRAWING 1250.01.
- G) STOPBAR LOCATIONS AT NON-SIGNALIZED INTERSECTIONS MAY BE ADJUSTED AS DIRECTED BY THE ENGINEER.
- H) UNLESS OTHERWISE SPECIFIED, HEATED IN PLACE THERMOPLASTIC MAY BE USED IN LIEU OF EXTRUDED THERMOPLASTIC FOR STOPBARS, SYMBOLS, CHARACTERS AND DIAGONALS. IF HEATED IN PLACE IS USED, IT SHALL BE PAID FOR USING THE EXTRUDED THERMOPLASTIC PAY ITEM.

INDEX

<u>SHEET NO.</u>	<u>DESCRIPTION</u>
PMP-1	PAVEMENT MARKING PLAN COVER SHEET
PMP-1A	PAVEMENT MARKING LEGEND & SCHEDULE
PMP-02 THRU PMP-23	PAVEMENT MARKING DETAILS

PLAN REVIEWED BY: N.C.D.O.T. SIGNING AND DELINEATION UNIT

A. I. Alqudwah, PE SIGNING & DELINEATION REGIONAL ENGINEER
B. Rashid SIGNING & DELINEATION PROJECT DESIGN ENGINEER

PLAN PREPARED BY: HNTB NORTH CAROLINA

R. B. Early, PE PROJECT ENGINEER
J. Phillips PROJECT DESIGNER

HNTB HNTB NORTH CAROLINA, P.C.
343 E. Six Forks Road, Suite 200
Raleigh, North Carolina 27609
C-1554

FINAL PAVEMENT MARKING SCHEDULE

MATERIAL	SYMBOL	DESCRIPTION
PAVEMENT MARKING		
THERMOPLASTIC (4", 90 MILS)		
	T8	WHITE MINI SKIP (2'/6')
	TA	WHITE EDGELINE
THERMOPLASTIC (4", 120 MILS)		
	TF	YELLOW SKIP
	TH	YELLOW SINGLE CENTER LINE
	TI	YELLOW DOUBLE CENTER LINE
THERMOPLASTIC (6", 90 MILS)		
	T6	WHITE EDGELINE
	T7	YELLOW EDGELINE
THERMOPLASTIC (6", 120 MILS)		
	T11	WHITE MINI SKIP (2'/6')
	T12	YELLOW MINI SKIP (2'/6')
	TJ	WHITE SKIP
	TK	WHITE MINISKIP (3'/9')
	TL	WHITE SOLID LANE LINE
THERMOPLASTIC (8", 90 MILS)		
	TP	YELLOW DIAGONAL
THERMOPLASTIC (12", 90 MILS)		
	TS	WHITE GORELINE
	TU	WHITE DIAGONAL
THERMOPLASTIC (24", 120 MILS)		
	T2	WHITE STOP BAR
POLYUREA (4", HIGHLY REFLECTIVE ELEMENTS)		
	VA	WHITE EDGELINE
	VI	DOUBLE YELLOW CENTERLINE
POLYUREA (6", HIGHLY REFLECTIVE ELEMENTS)		
	V6	WHITE EDGELINE
	V7	YELLOW EDGELINE
	VJ	10' WHITE SKIP
THERMOPLASTIC PAVEMENT MARKING SYMBOLS(90 MILS)		
	UA	LEFT TURN ARROW
	UB	RIGHT TURN ARROW
	UC	STRAIGHT ARROW
	UM	12" YIELD LINE TRIANGLE
	UT	U-TURN ARROW
PERMANENT RAISED PAVEMENT MARKERS		
	MA	YELLOW & YELLOW
	MB	CRYSTAL & RED
SNOWPLOWABLE RAISED PAVEMENT MARKERS		
	ME	YELLOW & YELLOW
	MF	CRYSTAL & RED

LEGEND

GENERAL

DIRECTION OF TRAFFIC FLOW
 NORTH ARROW
 PROPOSED PVMT. EXIST. PVMT.

PAVEMENT MARKINGS

PAVEMENT MARKING SYMBOLS

REVISIONS

4/14/15 P:\pmp\2514b_pmp.dwg
 \$\$\$USERNAME\$\$\$
 \$\$\$DATE\$\$\$

QA/QC STAGE: _____
 REVIEW: _____
 CONCUR: _____
 REVISE: _____
 VERIFY: _____

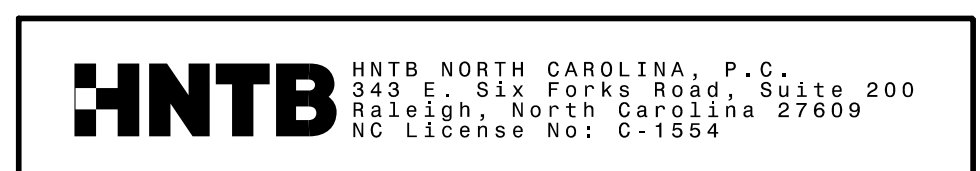

SEAL

APPROVED:

DATE: 2/10/2015

TRANSPORTATION
 MANAGEMENT PLAN
**FINAL PAVEMENT
 MARKING SCHEDULE
 & LEGEND**

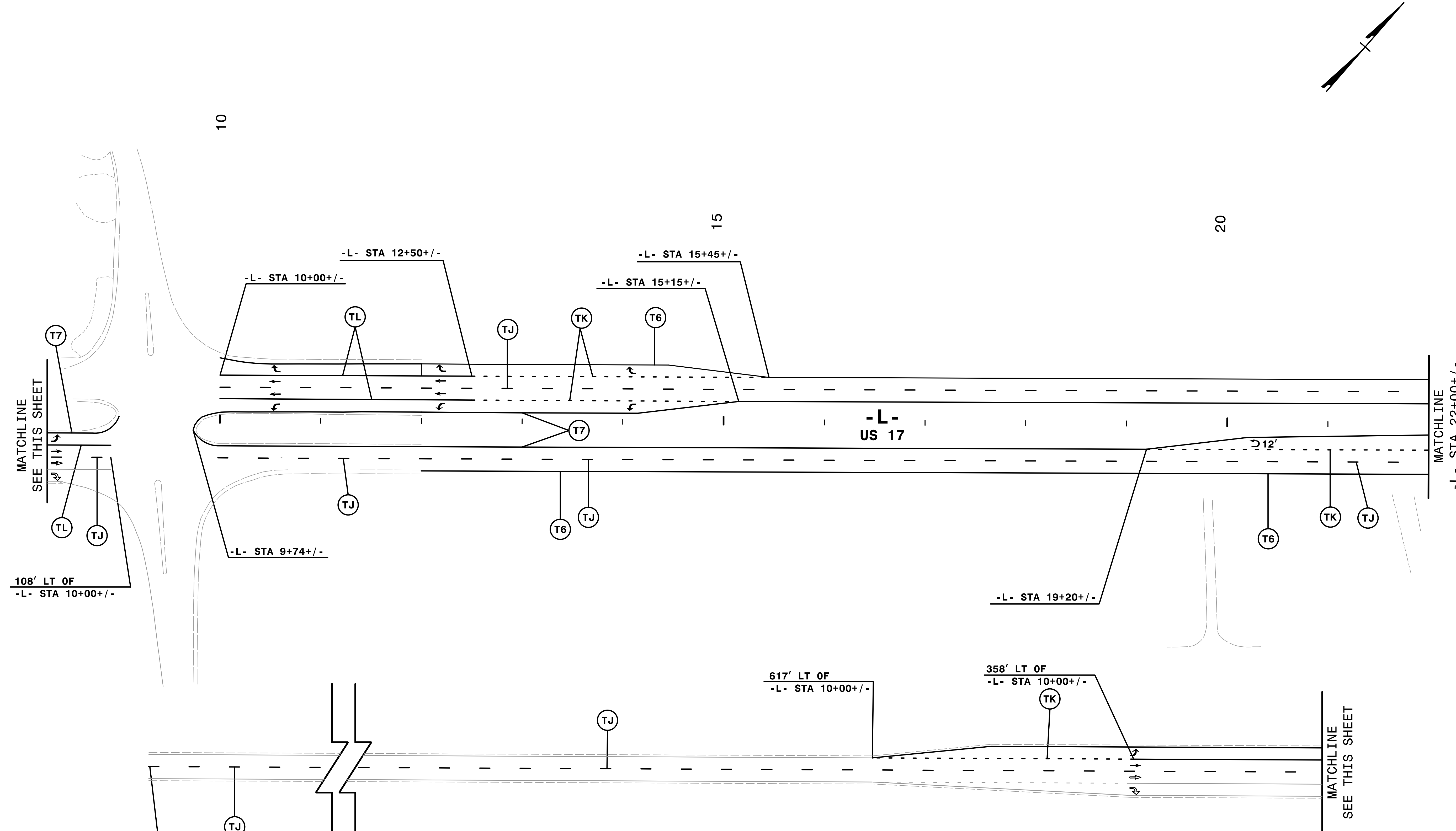
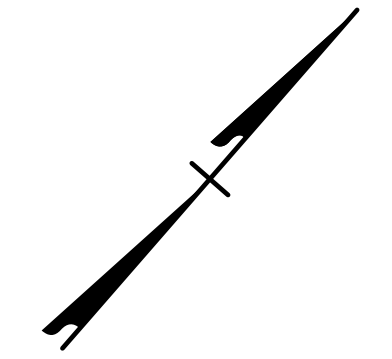

MATCHLINE
SEE THIS SHEET

108' LT OF
-L- STA 10+00+/-

TL TJ

MATCHLINE
-L- STA 22+00+/-
SEE SHEET PMP-3

BEGIN MARKING PROJECT
R-2514B
1687' LT OF
-L- STA 10+00+/-
TIE TO EXISTING

NOTE: ALL LANE WIDTHS ARE 12' UNLESS OTHERWISE SHOWN.

REVISIONS

Q/A/C STAGE:	
REVIEW:	
CONCUR:	
REVISE:	
VERIFY:	

4:\projects\pmp\2514b\pmp.d2.dgn
R-2514B-PMP-2.dwg
R-2514B-PMP-2.dwg

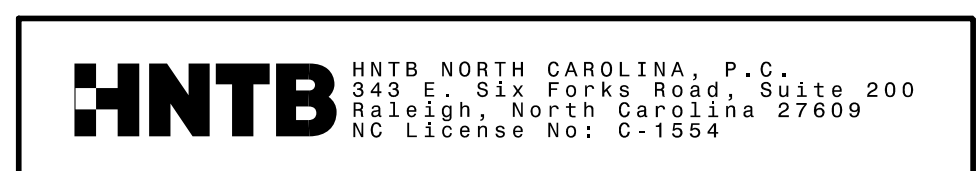

SEAL

APPROVED:

DocuSigned by:
Rhonda B. Early
F34CAF5AC6BF48A...

DATE: 2/10/2015

TRANSPORTATION
MANAGEMENT PLAN

**FINAL PAVEMENT
MARKING PLANS**

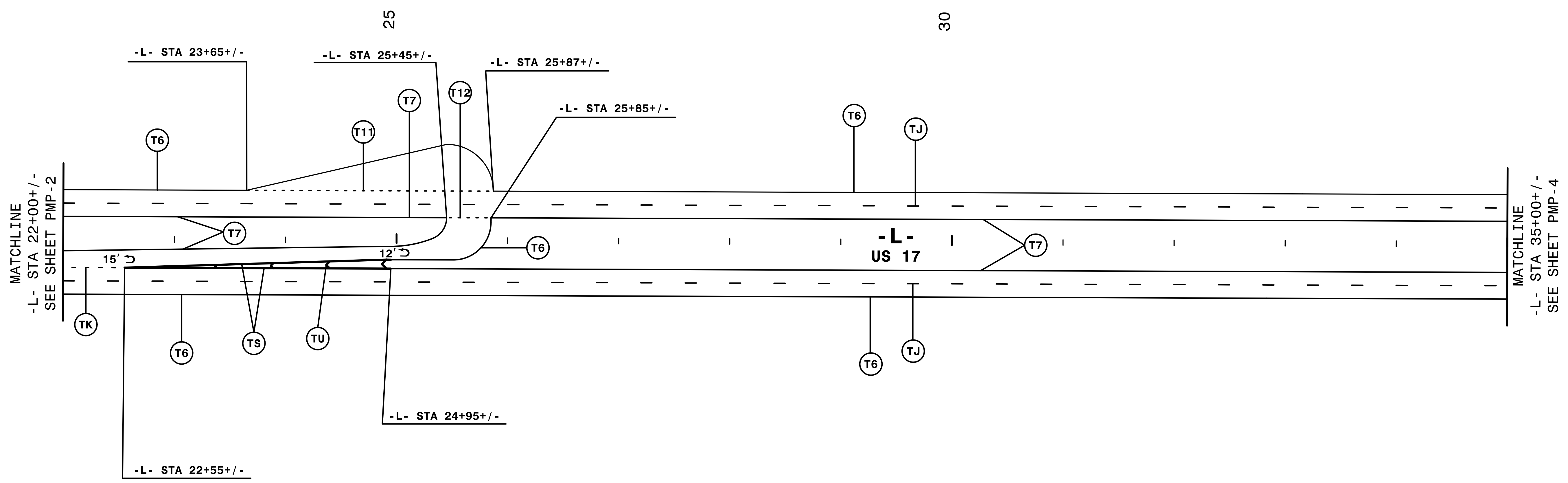
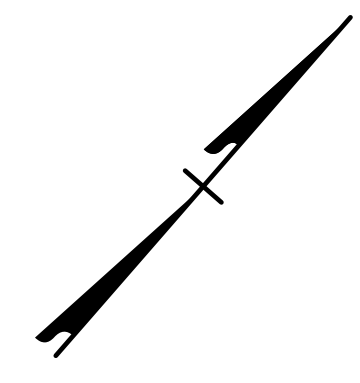

REVISIONS

QA/QC STAGE:	
REVIEW:	
CONCUR:	
REVISE:	
VERIFY:	

4:15:17 PM
 4:\pmp\pmp\2514b_pmp.d3.dgn
 \$\$\$USE RENAME\$\$\$

NOTE: ALL LANE WIDTHS ARE 12' UNLESS OTHERWISE SHOWN.

HNTB HNTB NORTH CAROLINA, P.C.
 343 E. Six Forks Road, Suite 200
 Raleigh, North Carolina 27609
 NC License No: C-1554

SEAL

APPROVED: *Rhonda B. Early*

DESIGNED BY: Rhonda B. Early
 F34CAF5AD6BF48A...

DATE: 2/10/2015

TRANSPORTATION
 MANAGEMENT PLAN

**FINAL PAVEMENT
 MARKING PLANS**

8/17/99

REVISIONS

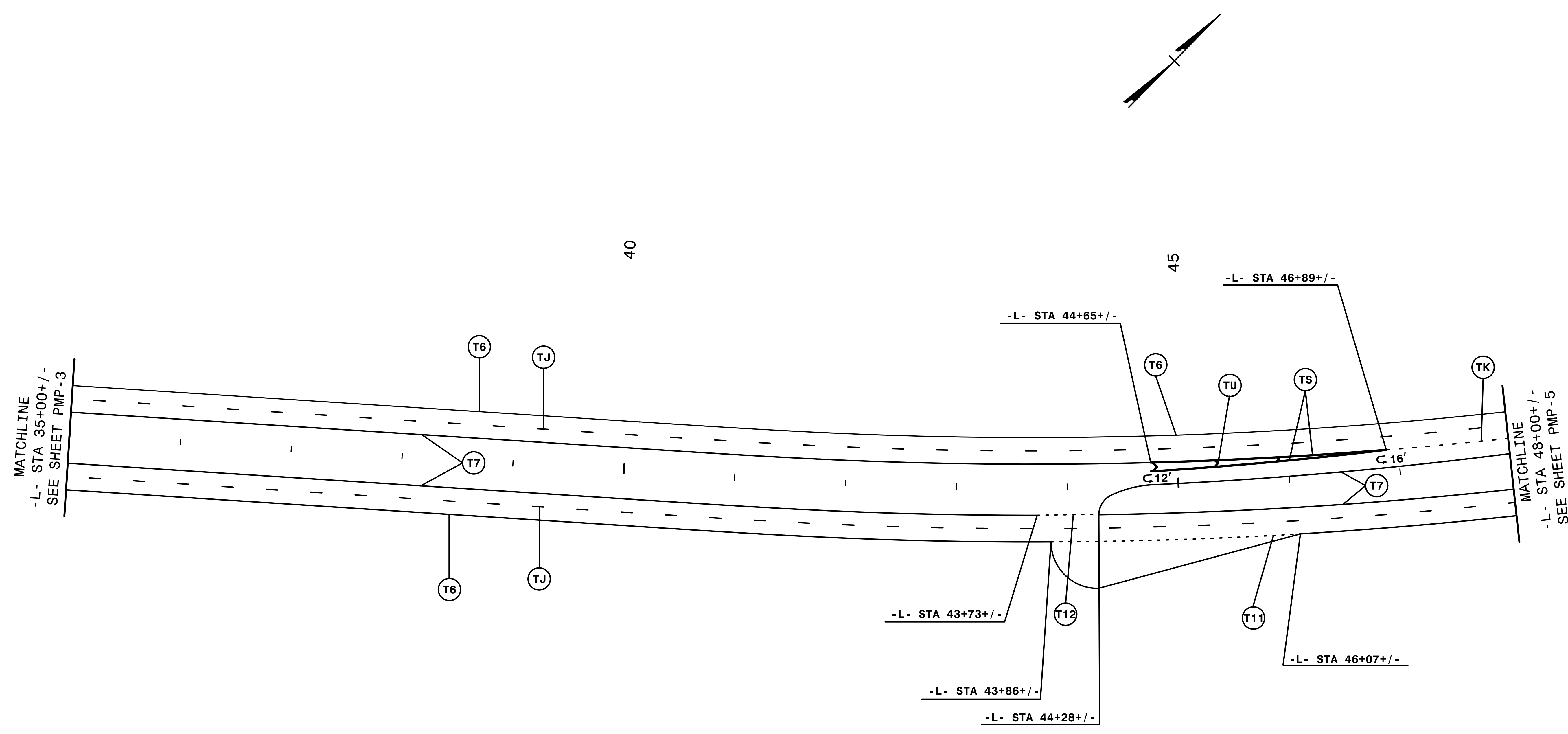

4:16:00 PM 4/25/14b_pmp_d4.dgn
\$\$\$\$\$USERNAME\$\$\$\$\$

QA/QC STAGE:	
REVIEW:	
CONCUR:	
REVISE:	
VERIFY:	

NOTE: ALL LANE WIDTHS ARE 12' UNLESS OTHERWISE SHOWN.

HNTB HNTB NORTH CAROLINA, P.C.
343 E. Six Forks Road, Suite 200
Raleigh, North Carolina 27609
NC License No: C-1554

SEAL

APPROVED: *Rhonda B. Eirly*

DocuSigned by:
Rhonda B. Eirly
F34CAF5AC66F48A...

DATE: 2/10/2015

TRANSPORTATION
MANAGEMENT PLAN

**FINAL PAVEMENT
MARKING PLANS**

8/17/99

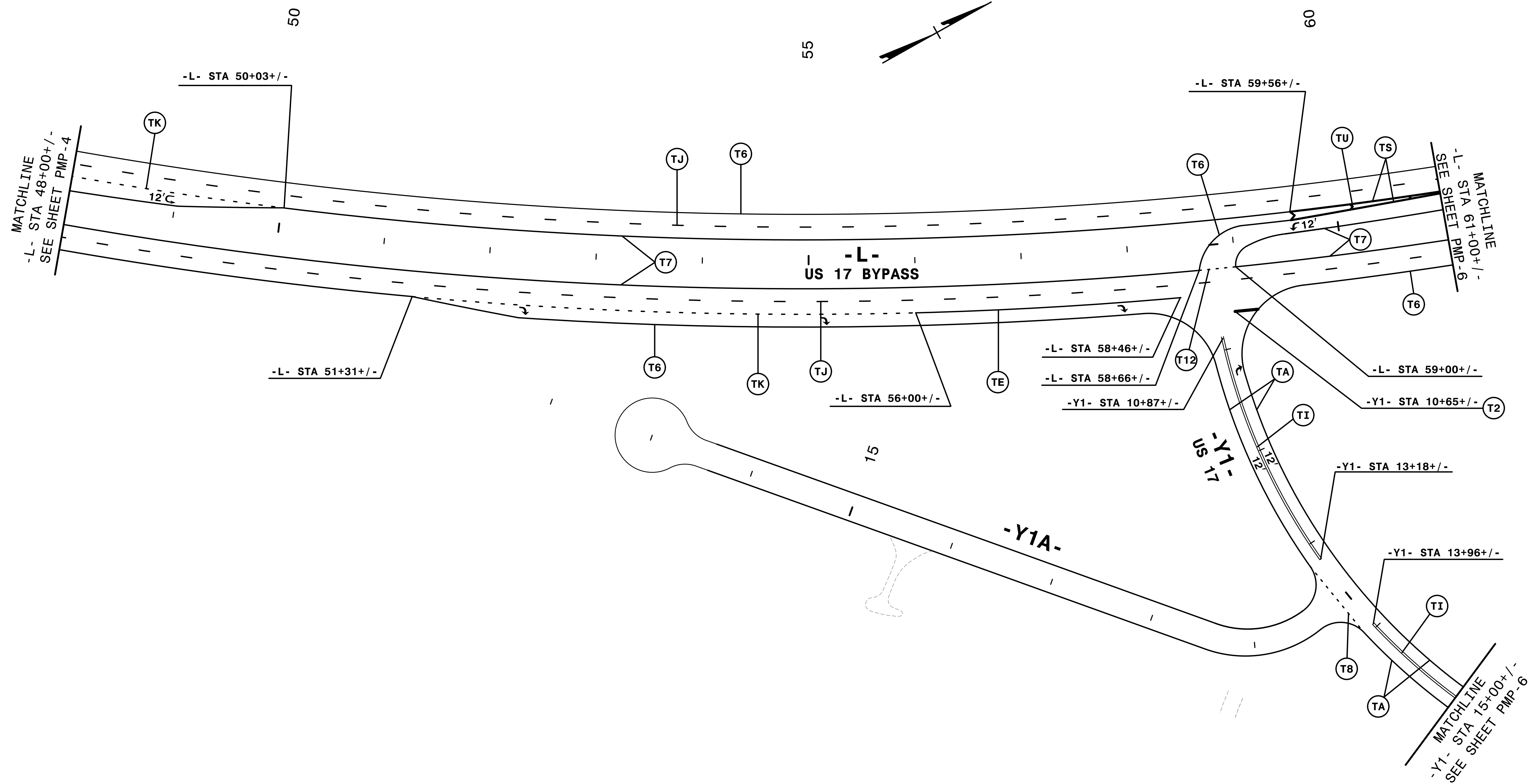

REVISIONS

416517.dwg
P:\Plans\2514b.pmp.dwg
Rhonda B. Early

Q/A/C STAGE:	
REVIEW:	
CONCUR:	
REVISE:	
VERIFY:	

NOTE: ALL LANE WIDTHS ARE 12' UNLESS OTHERWISE SHOWN.

HNTB HNTB NORTH CAROLINA, P.C.
343 E. Six Forks Road, Suite 200
Raleigh, North Carolina 27609
NC License No: C-1554

SEAL

APPROVED: *Rhonda B. Early*

DocuSigned by:
Rhonda B. Early
F34CAF5AC6BF48A

DATE: 2/10/2015

TRANSPORTATION
MANAGEMENT PLAN

**FINAL PAVEMENT
MARKING PLANS**

8/17/99

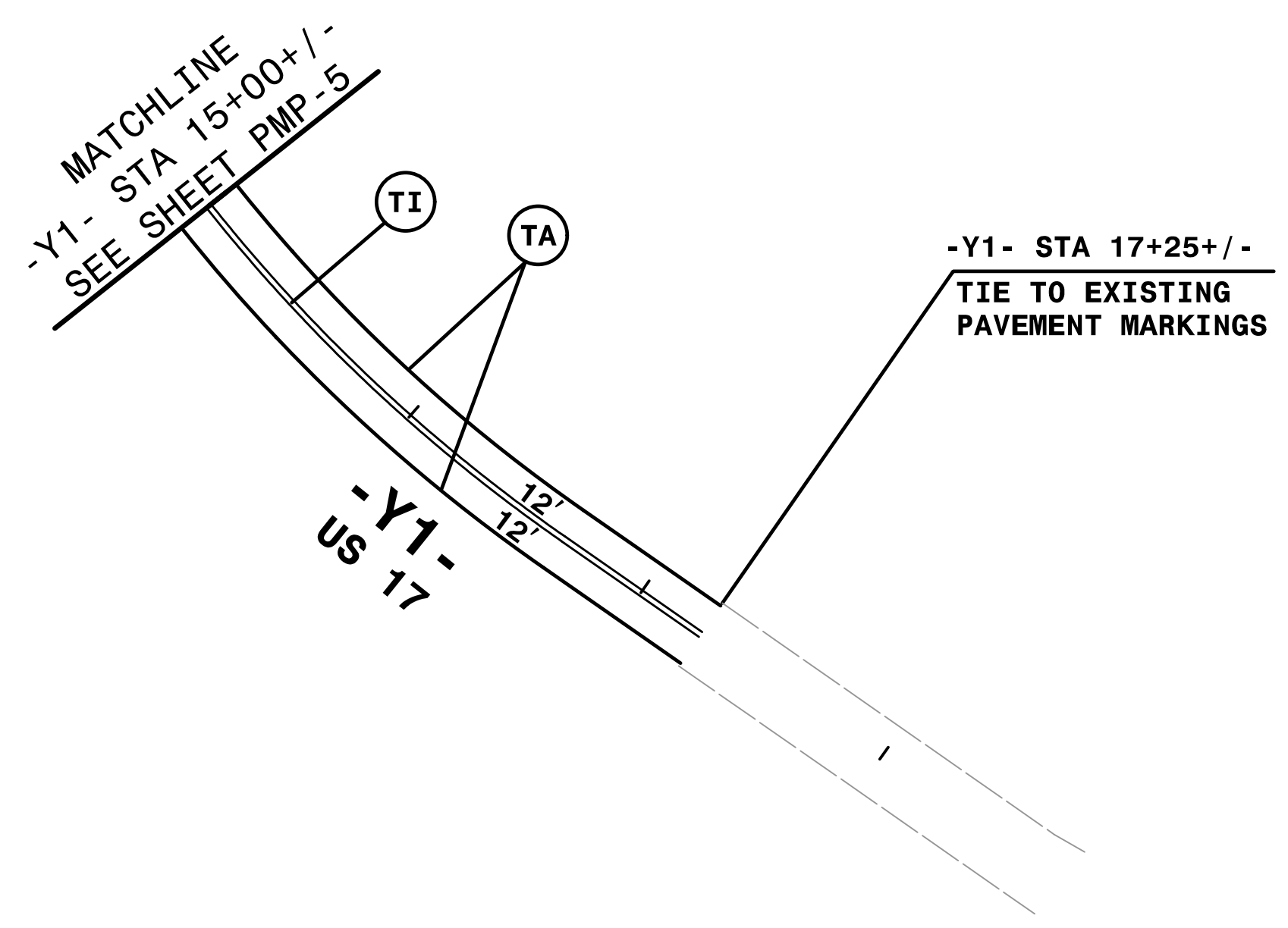
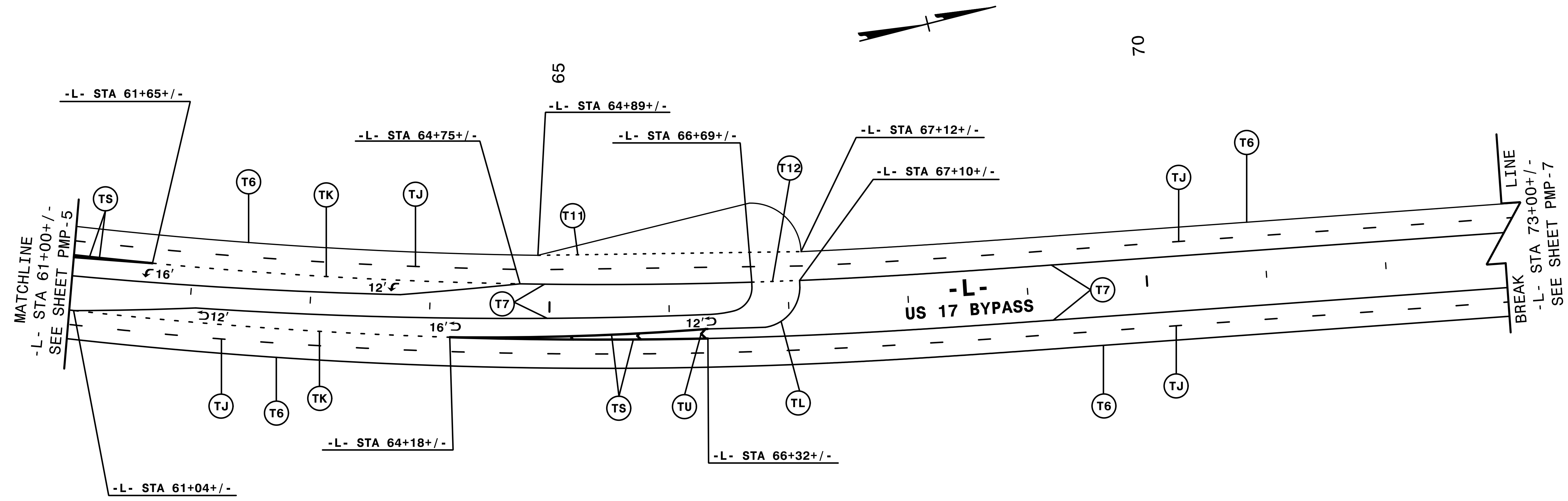

NOTE: ALL LANE WIDTHS ARE 12' UNLESS OTHERWISE SHOWN.

REVISIONS

4:16:48 PM 4/15/2015 2514b_pmp.dwg

QA/QC STAGE:

REVIEW:	_____
CONCUR:	_____
REVISE:	_____
VERIFY:	_____

HNTB HNTB NORTH CAROLINA, P.C.
343 E. Six Forks Road, Suite 200
Raleigh, North Carolina 27609
NC License No: C-1554

SEAL

APPROVED: *Rhonda B. Early*

DATE: 2/10/2015

TRANSPORTATION
MANAGEMENT PLAN

**FINAL PAVEMENT
MARKING PLANS**

8/17/99

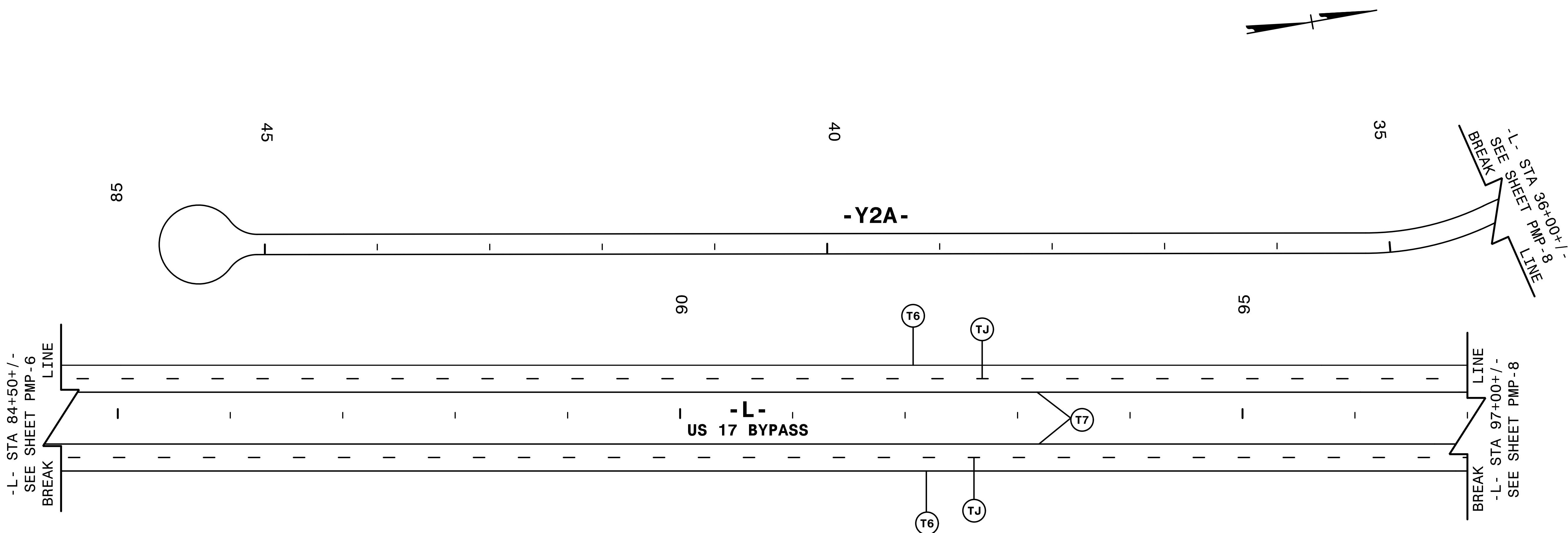

REVISIONS

4:\7\07\25\14b_pmp.d7.dgn
\$\$\$\$\$USERNAME\$\$\$\$\$

QA/QC STAGE:	
REVIEW:	
CONCUR:	
REVISE:	
VERIFY:	

NOTE: ALL LANE WIDTHS ARE 12' UNLESS OTHERWISE SHOWN.

HNTB HNTB NORTH CAROLINA, P.C.
343 E. Six Forks Road, Suite 200
Raleigh, North Carolina 27609
NC License No: C-1554

SEAL

APPROVED: *Rhonda B. Early*

DATE: 2/10/2015

TRANSPORTATION
MANAGEMENT PLAN

**FINAL PAVEMENT
MARKING PLANS**

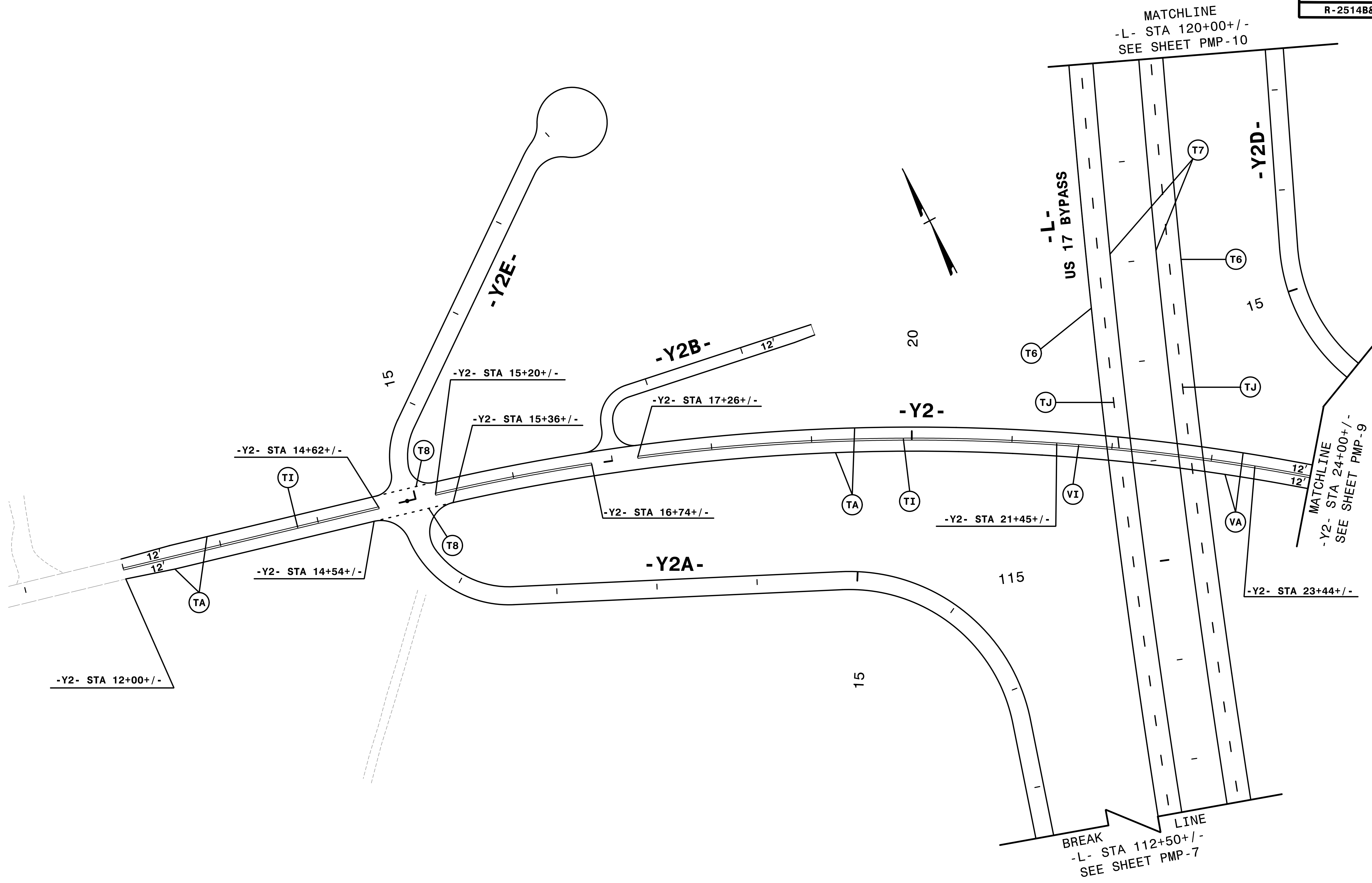

NOTE: ALL LANE WIDTHS ARE 12' UNLESS OTHERWISE SHOWN.

HNTB HNTB NORTH CAROLINA, P.C. 200
 343 E. Six Forks Road, Suite 200
 Raleigh, North Carolina 27609
 NC License No: C-1554

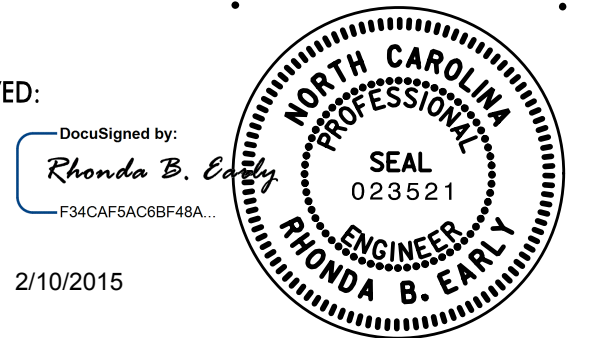
SEAL
 APPROVED: 
 DATE: 2/10/2015

TRANSPORTATION
 MANAGEMENT PLAN
**FINAL PAVEMENT
 MARKING PLANS**

4:17:48 PM
 P:\Projects\2514B-C\2514b-pmp-d8.dgn
 33:33:00
 QA/QC STAGE:

REVIEW:	_____
CONCUR:	_____
REVISE:	_____
VERIFY:	_____

REVISIONS

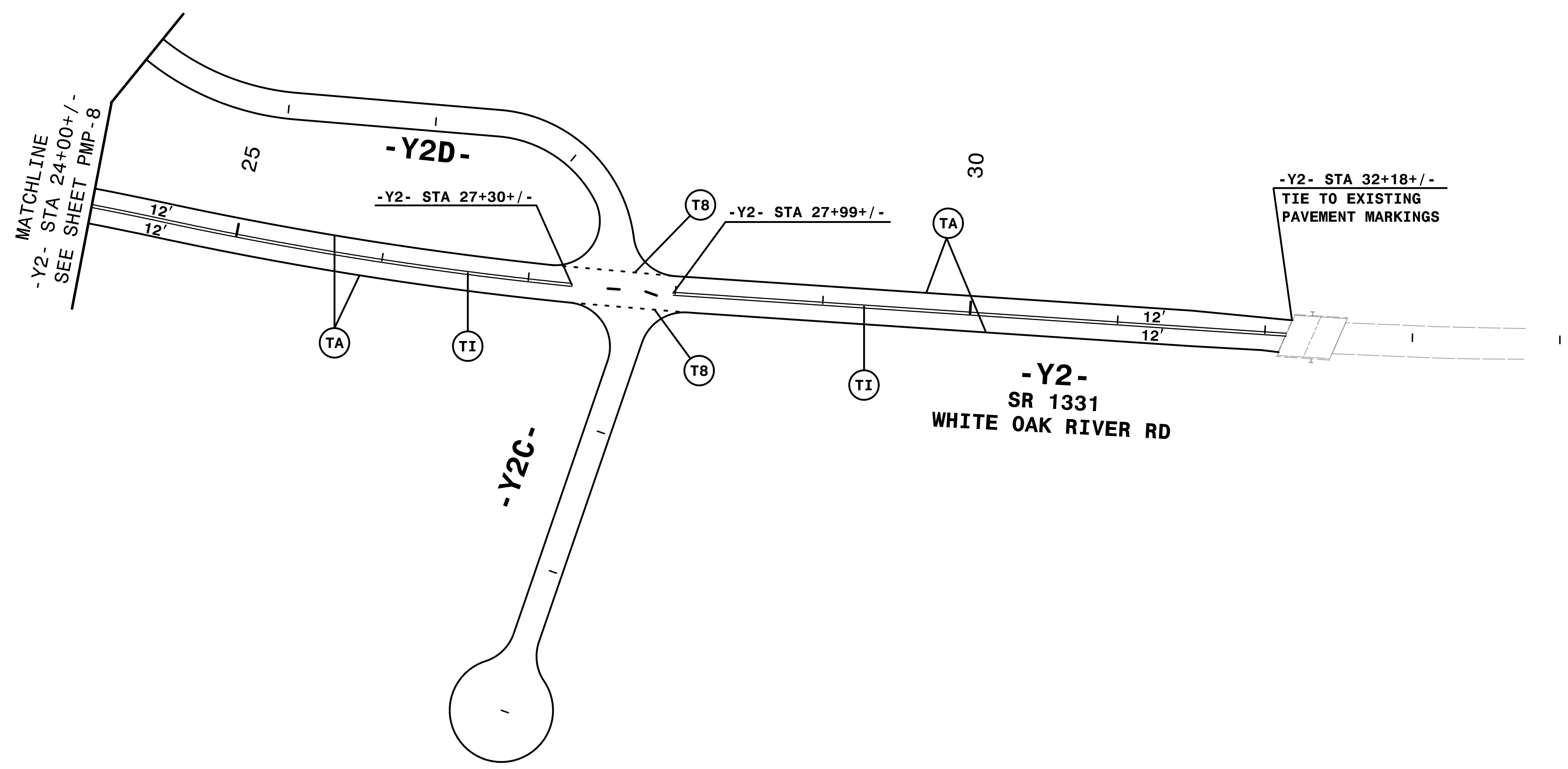

NOTE: ALL LANE WIDTHS ARE 12' UNLESS OTHERWISE SHOWN.

HNTB HNTB NORTH CAROLINA, P.C. Suite 200
 343 E. Six Forks Road, Suite 200
 Raleigh, North Carolina 27609
 NC License No: C-1554

SEAL
 APPROVED: *Rhonda B. Early*
Drawn/signed by: Rhonda B. Early, P.E., F.S.M.C.P.S.A.C.068748A.
 DATE: 2/10/2015

TRANSPORTATION
 MANAGEMENT PLAN
**FINAL PAVEMENT
 MARKING PLANS**

REVISIONS

REVIEW:	_____
CONCUR:	_____
REVISE:	_____
VERIFY:	_____

4:18:29 PM
 3:33:53 PM
 3:33:53 PM
 QA/QC STAGE:
 P:\pmp\2514b_pmp-d9.dgn

8/17/99

REVISIONS

4:16 PM 2/10/2015 4b_pmp.d10.dgn

QA/QC STAGE:

REVIEW: _____
 CONCUR: _____
 REVISE: _____
 VERIFY: _____

MATCHLINE
 -L- STA 120+00 +/-
 SEE SHEET PMP-8

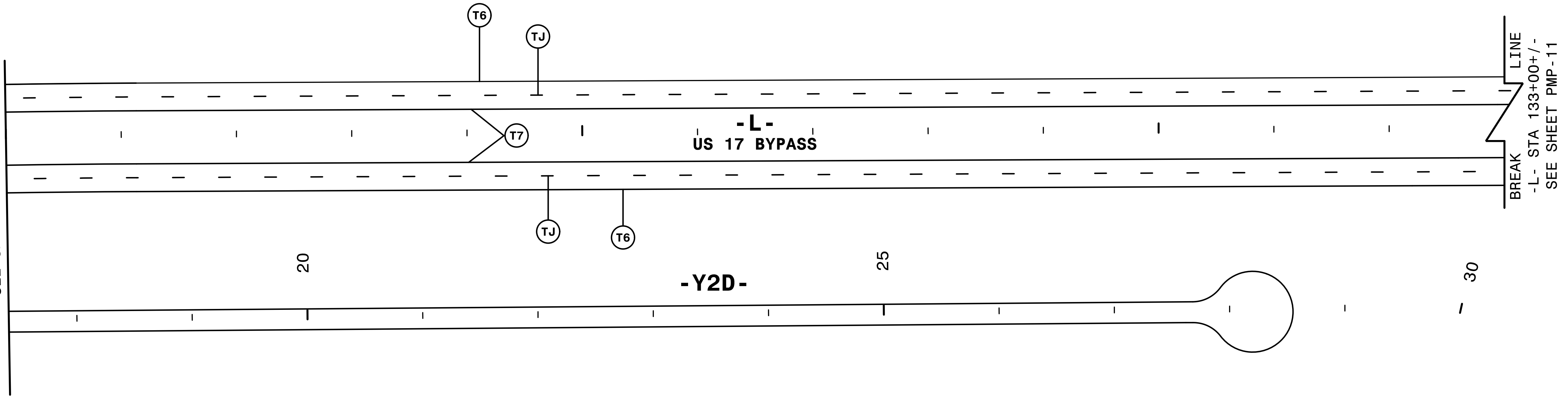

LINE
 -L- STA 133+00 +/-
 SEE SHEET PMP-11

NOTE: ALL LANE WIDTHS ARE 12' UNLESS OTHERWISE SHOWN.

HNTB HNTB NORTH CAROLINA, P.C.
 343 E. Six Forks Road, Suite 200
 Raleigh, North Carolina 27609
 NC License No: C-1554

SEAL

APPROVED: *Rhonda B. Eirly*

DATE: 2/10/2015

TRANSPORTATION
 MANAGEMENT PLAN

**FINAL PAVEMENT
 MARKING PLANS**

8/17/99

REVISIONS

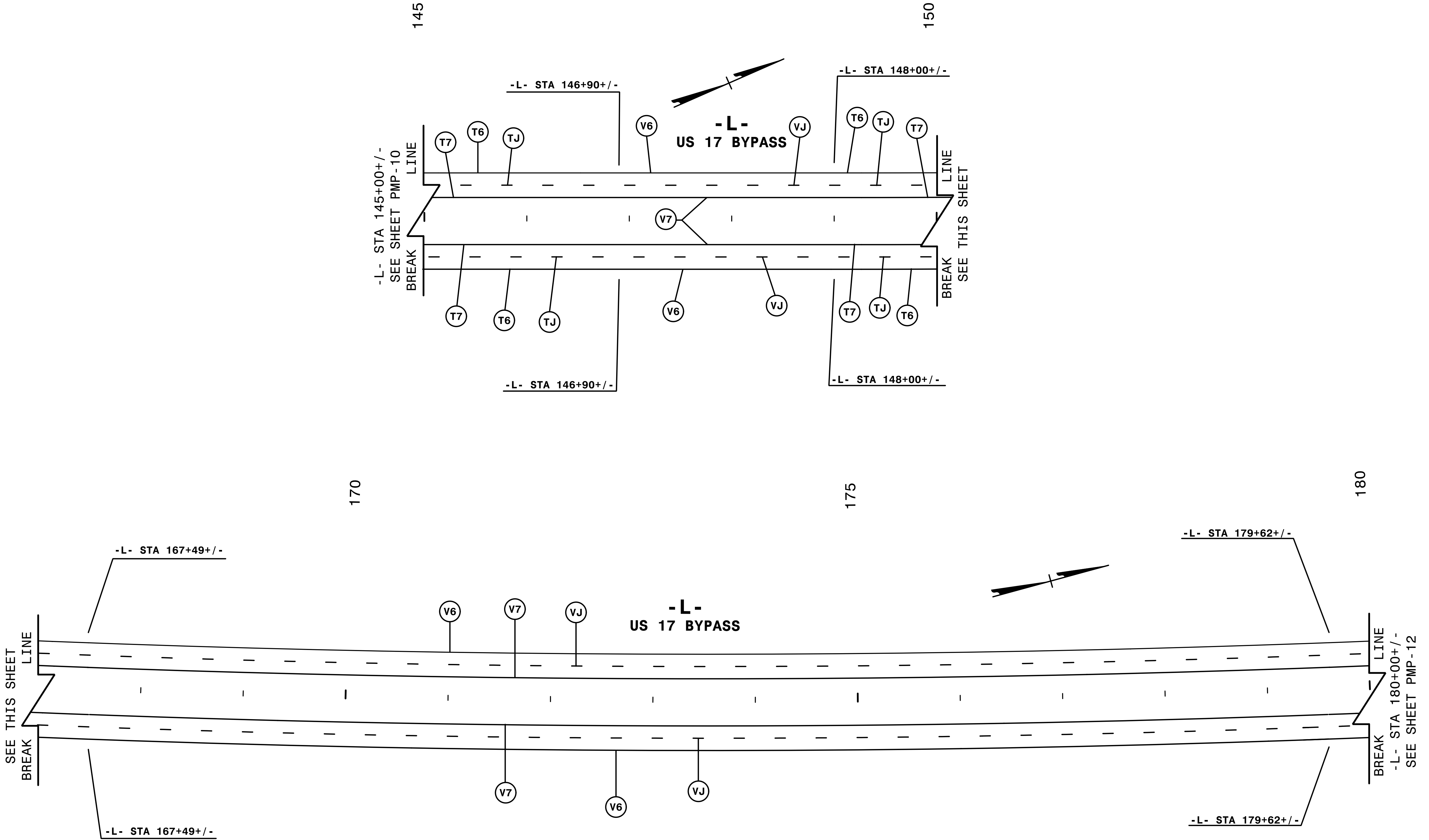

NOTE: ALL LANE WIDTHS ARE 12' UNLESS OTHERWISE SHOWN.

4:\projects\pmp\2514b_pmp.d11.dgn

Q&A/C STAGE:

REVIEW:	
CONCUR:	
REVISE:	
VERIFY:	

HNTB HNTB NORTH CAROLINA, P.C.
 343 E. SIX FORKS ROAD, SUITE 200
 RALEIGH, NORTH CAROLINA 27609
 NC LICENSE NO: C-1554

SEAL

APPROVED: *Rhonda B. Early*

DESIGNED BY: Rhonda B. Early
 F34CAF5AC66F48A

DATE: 2/10/2015

TRANSPORTATION
 MANAGEMENT PLAN

**FINAL PAVEMENT
 MARKING PLANS**

8/17/99

REVISIONS

4:\99\pmp\pmp\2514b_pmp.d12.dgn
\$\$\$\$\$USERNAME\$\$\$\$\$

QA/QC STAGE:

REVIEW: _____
 CONCUR: _____
 REVISE: _____
 VERIFY: _____

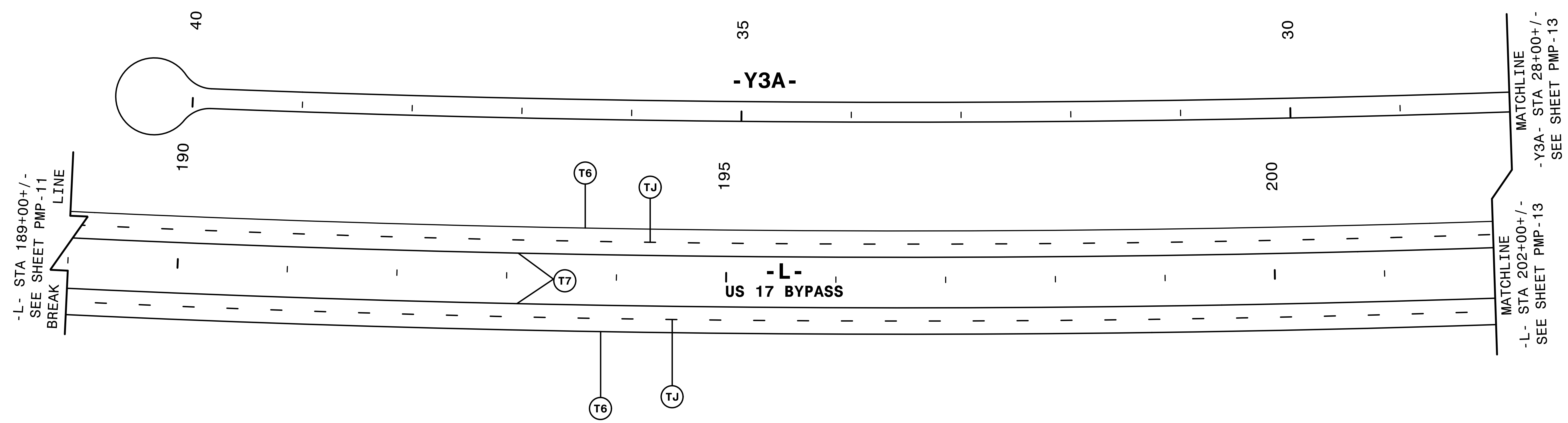

NOTE: ALL LANE WIDTHS ARE 12' UNLESS OTHERWISE SHOWN.

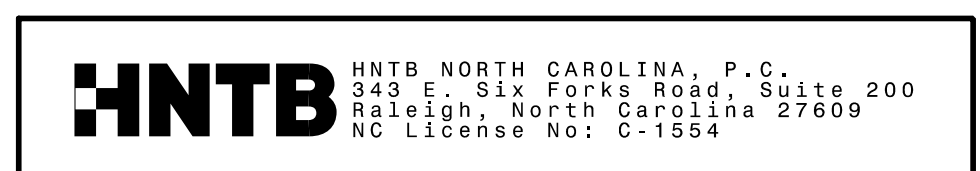

SEAL

APPROVED: _____

DocuSigned by:
 Rhonda B. Early
 F34CAF5AC66F48A...

DATE: 2/10/2015

TRANSPORTATION
 MANAGEMENT PLAN

**FINAL PAVEMENT
 MARKING PLANS**

8/17/99

4:\projects\2514b\pmp\dl3.dgn \$\$\$\$USERNAME\$\$\$\$	REVISIONS
QA/QC STAGE:	
REVIEW:	
CONCUR:	
REVISE:	
VERIFY:	

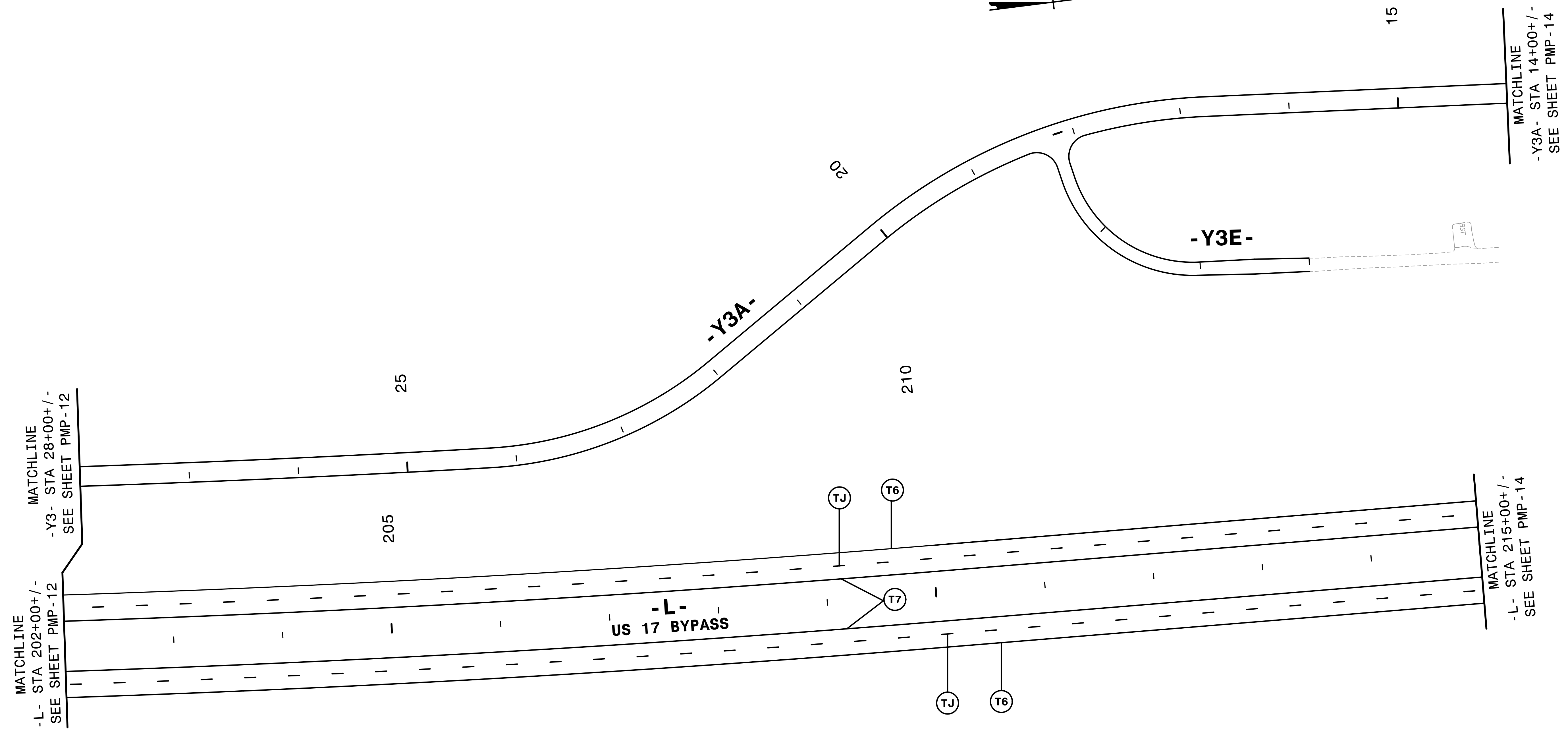

NOTE: ALL LANE WIDTHS ARE 12' UNLESS OTHERWISE SHOWN.

HNTB HNTB NORTH CAROLINA, P.C.
 343 E. SIX FORKS ROAD, SUITE 200
 RALEIGH, NORTH CAROLINA 27609
 NC LICENSE NO: C-1554

SEAL

APPROVED: *Rhonda B. Early*

DATE: 2/10/2015

TRANSPORTATION
 MANAGEMENT PLAN

**FINAL PAVEMENT
 MARKING PLANS**

8/17/99

REVISIONS

4:24 PM 8/17/99 2514b.pmp.d14.dgn
\$\$\$\$\$USERNAME\$\$\$\$\$

QA/QC STAGE:

REVIEW:	_____
CONCUR:	_____
REVISE:	_____
VERIFY:	_____

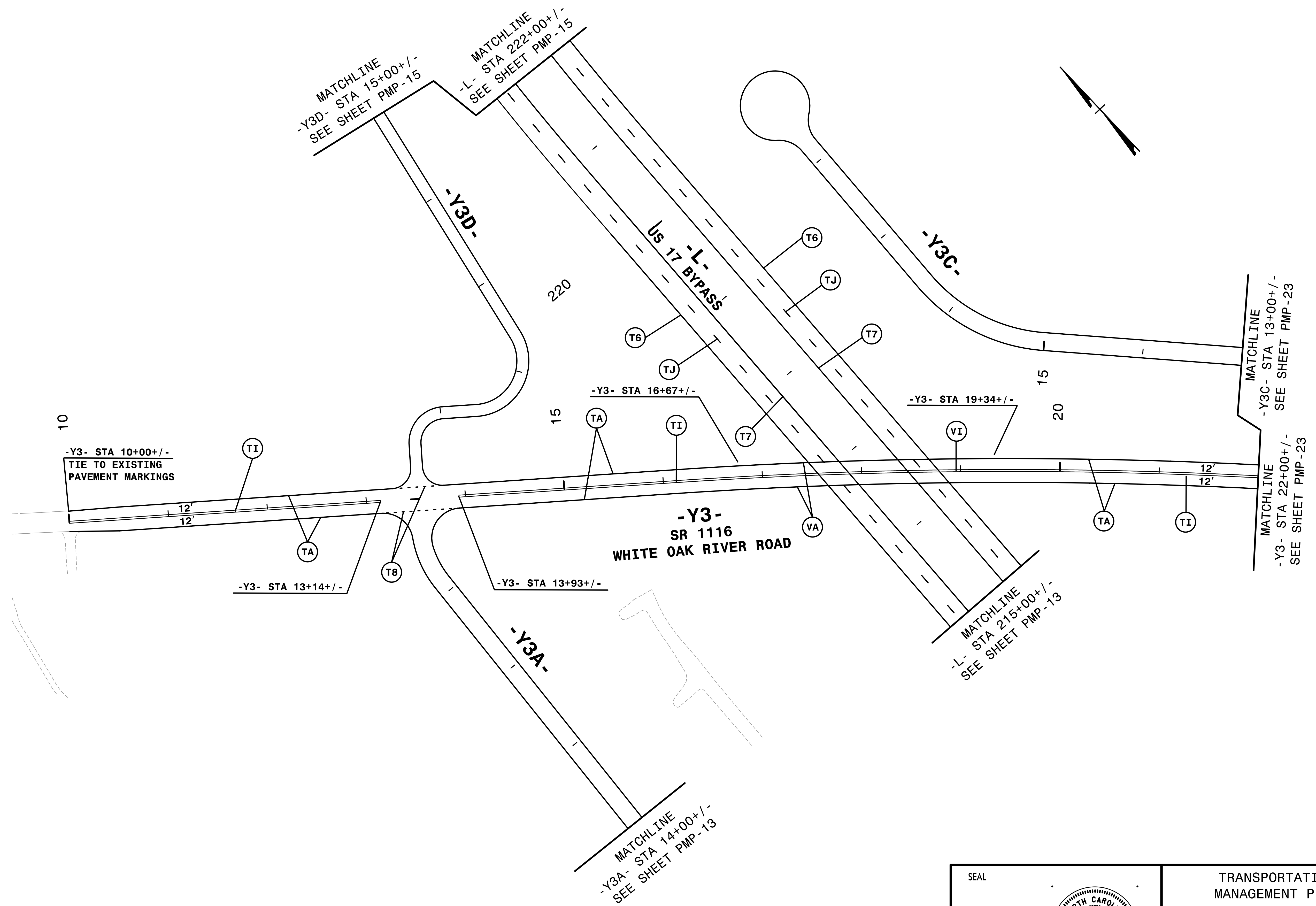

NOTE: ALL LANE WIDTHS ARE 12' UNLESS OTHERWISE SHOWN.

HNTB HNTB NORTH CAROLINA, P.C.
343 E. Six Forks Road, Suite 200
Raleigh, North Carolina 27609
NC License No: C-1554

SEAL

APPROVED: *Rhonda B. Eirly*

DATE: 2/10/2015

TRANSPORTATION
MANAGEMENT PLAN

**FINAL PAVEMENT
MARKING PLANS**

8/17/99

REVISIONS

4:21:57 PM
P:\Projects\2514b_pmp.d15.dgn
\$\$\$\$\$
\$\$\$\$\$
\$\$\$\$\$
\$\$\$\$\$
\$\$\$\$\$

QA/QC STAGE:	
REVIEW:	
CONCUR:	
REVISE:	
VERIFY:	

NOTE: ALL LANE WIDTHS ARE 12' UNLESS OTHERWISE SHOWN.

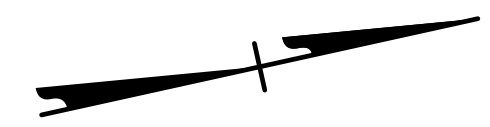
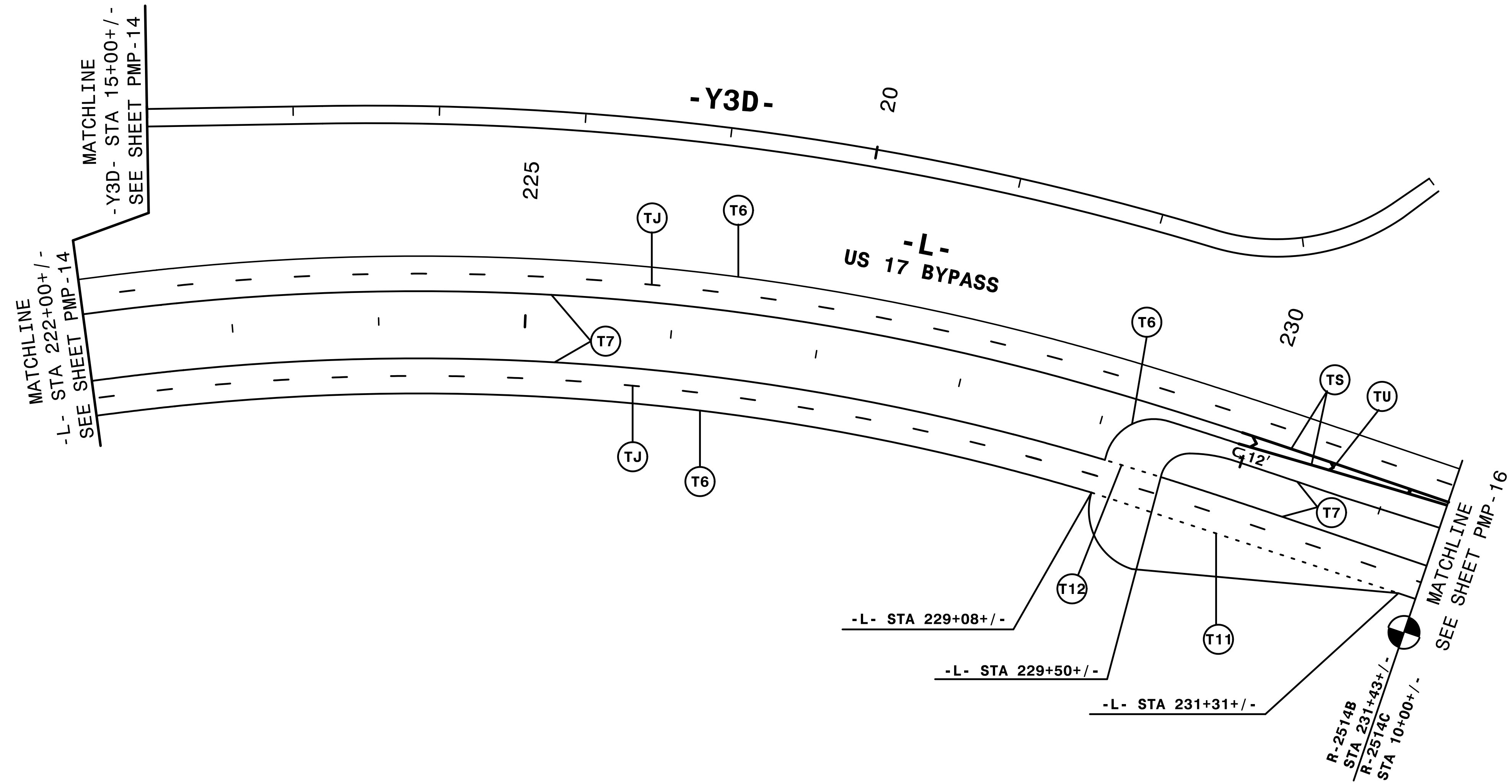

HNTB HNTB NORTH CAROLINA, P.C.
343 E. Six Forks Road, Suite 200
Raleigh, North Carolina 27609
NC License No: C-1554

SEAL

APPROVED:

DocuSigned by:
Rhonda B. Early
F34CAF5AC68F48A

DATE: 2/10/2015

TRANSPORTATION
MANAGEMENT PLAN

**FINAL PAVEMENT
MARKING PLANS**

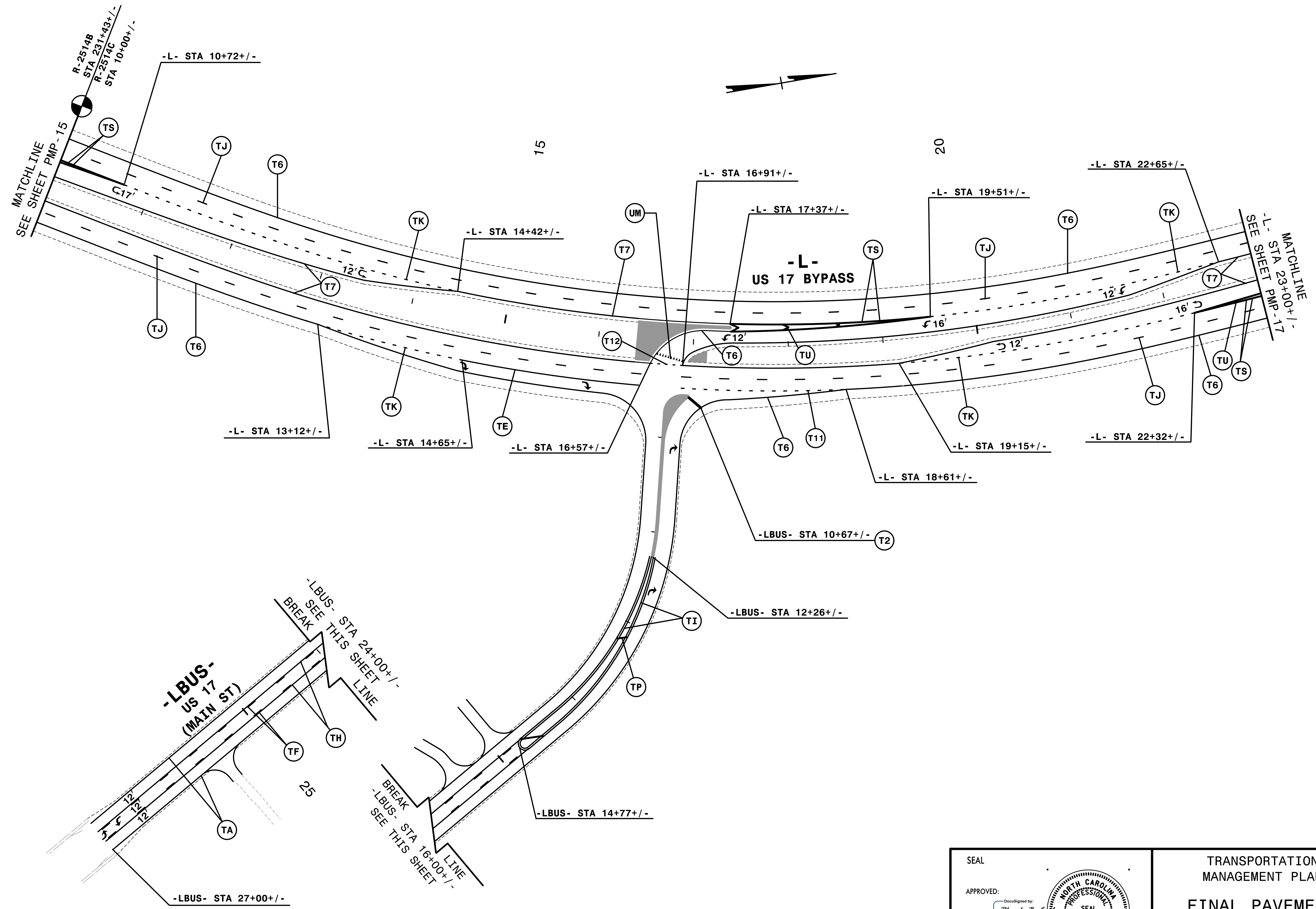

REVISIONS

4:24:02 PM \\ms\p\2514c.pmp.d17.dgn
 \$\$\$USERNAME\$\$\$

QA/QC STAGE:	
REVIEW:	
CONCUR:	
REVISE:	
VERIFY:	

NOTE: ALL LANE WIDTHS ARE 12' UNLESS OTHERWISE SHOWN.

HNTB HNTB NORTH CAROLINA, P.C.
 343 E. Six Forks Road, Suite 200
 Raleigh, North Carolina 27609
 NC License No: C-1554

SEAL

APPROVED: *Rhonda B. Eirly*

Disciplined by: _____
 FS4CAFSA068F48A

DATE: 2/10/2015

TRANSPORTATION
 MANAGEMENT PLAN

**FINAL PAVEMENT
 MARKING PLANS**

8/17/99

REVISIONS

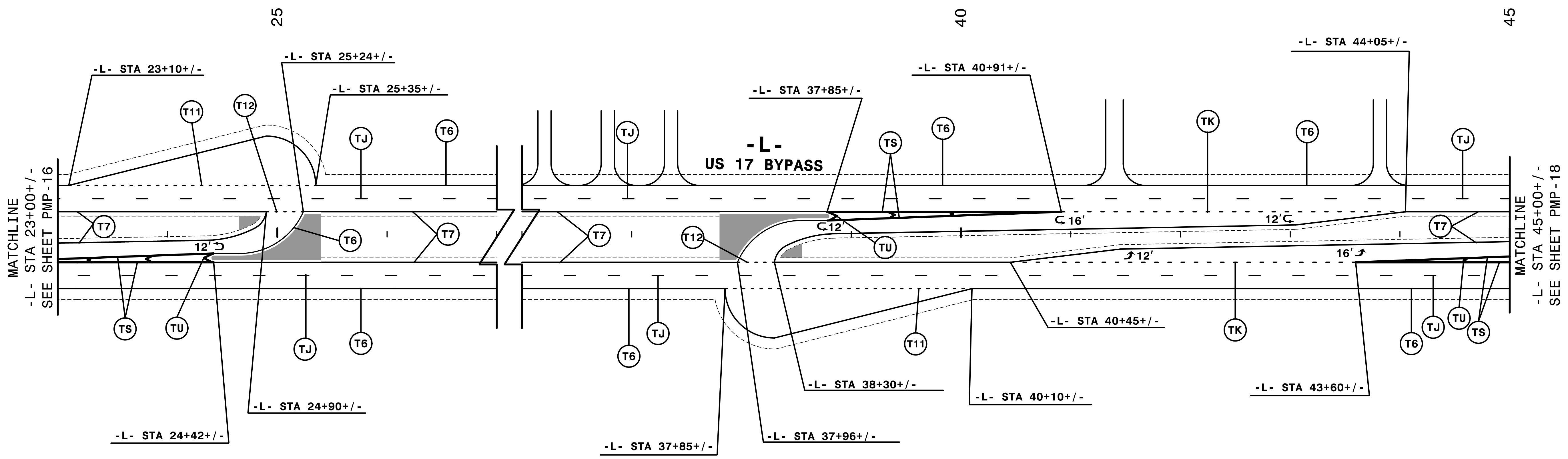

NOTE: ALL LANE WIDTHS ARE 12' UNLESS OTHERWISE SHOWN.

4:26:27 PM 8/17/2015 c:\pmp\d18.dgn

QA/QC STAGE:

REVIEW:	
CONCUR:	
REVISE:	
VERIFY:	

HNTB HNTB NORTH CAROLINA, P.C.
 343 E. Six Forks Road, Suite 200
 Raleigh, North Carolina 27609
 NC License No: C-1554

SEAL

APPROVED: *Rhonda B. Eirly*

Disc: Signed by: *Rhonda B. Eirly*
 FS4C4F5AC6B6F48A

DATE: 2/10/2015

TRANSPORTATION
 MANAGEMENT PLAN

**FINAL PAVEMENT
 MARKING PLANS**

8/17/99

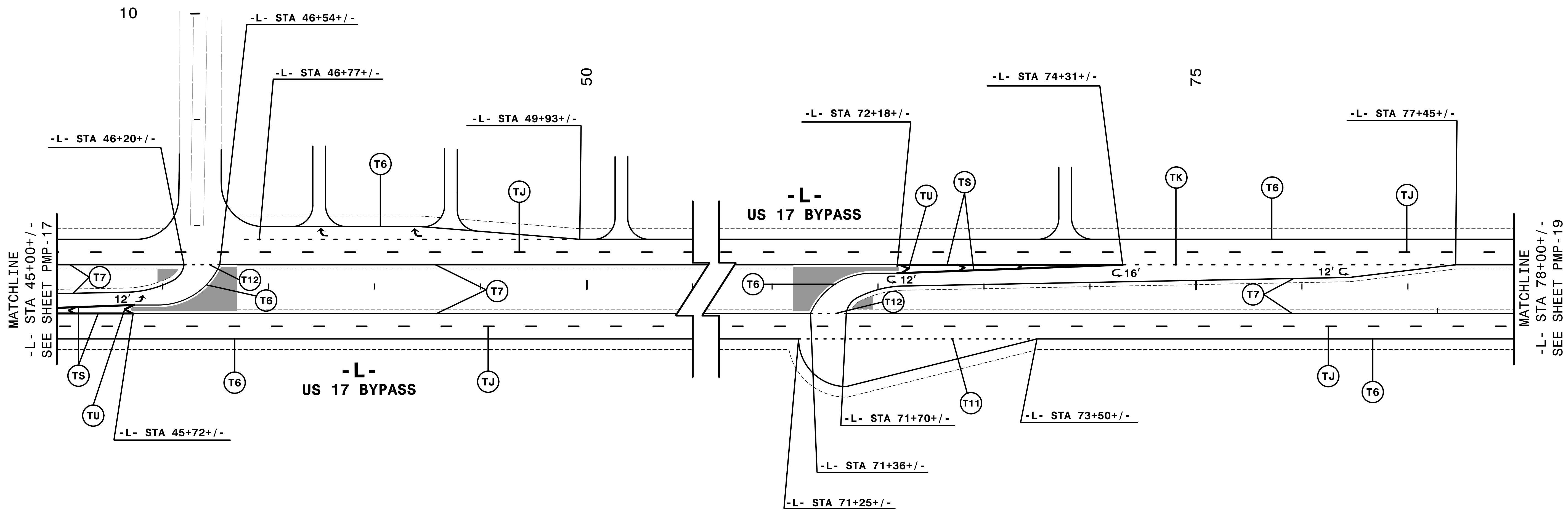

MATCHLINE
-L- STA 45+00+/-
SEE SHEET PMP-17

MATCHLINE
-L- STA 78+00+/-
SEE SHEET PMP-19

REVISIONS

QA/QC STAGE:	
REVIEW:	
CONCUR:	
REVISE:	
VERIFY:	

NOTE: ALL LANE WIDTHS ARE 12' UNLESS OTHERWISE SHOWN.

4:23:38 PM \\ms\p\2514c.pmp.d19.dgn

HNTB HNTB NORTH CAROLINA, P.C.
343 E. Six Forks Road, Suite 200
Raleigh, North Carolina 27609
NC License No: C-1554

SEAL

APPROVED:

Desigined by:
Rhonda B. Eirly
F34CAF5AC6BF48A

DATE: 2/10/2015

TRANSPORTATION
MANAGEMENT PLAN

**FINAL PAVEMENT
MARKING PLANS**

8/17/99

REVISIONS

MATCHLINE

BREAK LINE

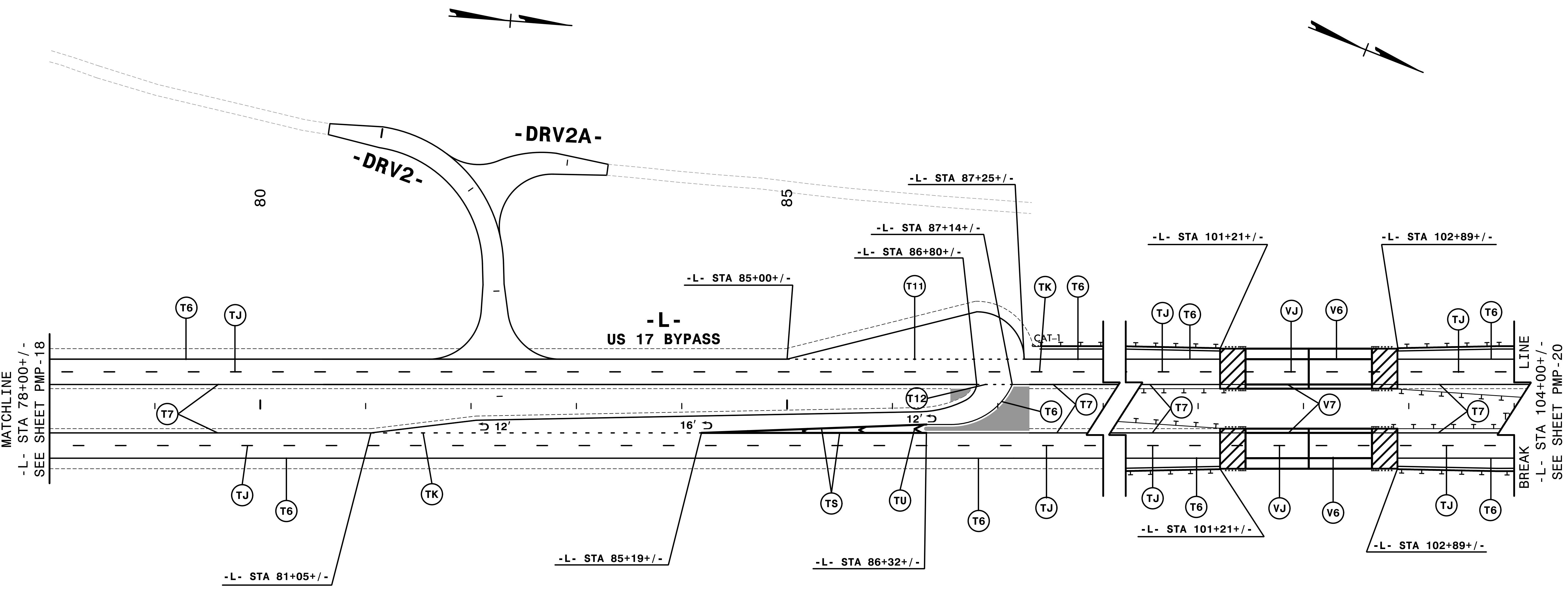

-L- STA 78+00+/-
SEE SHEET PMP-18

-L- STA 104+00+/-
SEE SHEET PMP-20

NOTE: ALL LANE WIDTHS ARE 12' UNLESS OTHERWISE SHOWN.

4:24:18 PM \\msn\y2514c.pmp.d20.dgn
\$\$\$\$\$USERNAME\$\$\$\$\$

QA/QC STAGE:	
REVIEW:	
CONCUR:	
REVISE:	
VERIFY:	

HNTB HNTB NORTH CAROLINA, P.C.
343 E. Six Forks Road, Suite 200
Raleigh, North Carolina 27609
NC License No: C-1554

SEAL

APPROVED: *Rhonda B. Eirly*

DESIGNED BY: *Rhonda B. Eirly*
F34CAFSAC8BF48A...

DATE: 2/10/2015

TRANSPORTATION
MANAGEMENT PLAN

**FINAL PAVEMENT
MARKING PLANS**

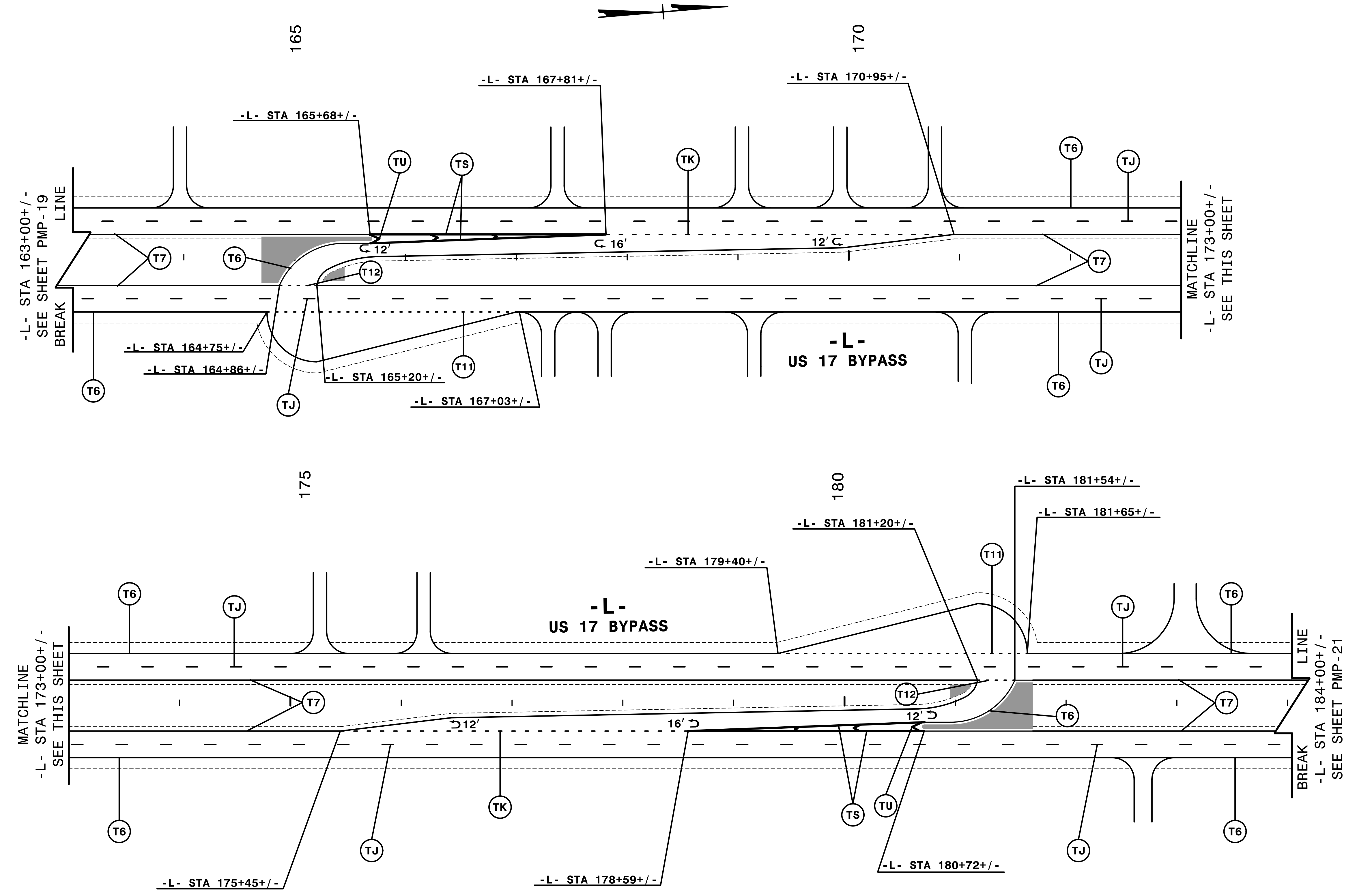

-L- STA 163+00+/-
SEE SHEET PMP-19
BREAK
LINE

MATCHLINE
-L- STA 173+00+/-
SEE THIS SHEET

MATCHLINE
-L- STA 173+00+/-
SEE THIS SHEET

LINE
BREAK
-L- STA 184+00+/-
SEE SHEET PMP-21

NOTE: ALL LANE WIDTHS ARE 12' UNLESS OTHERWISE SHOWN.

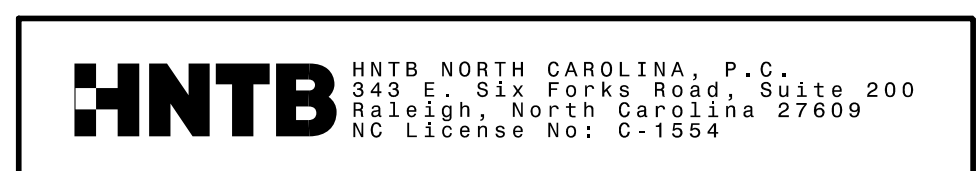

SEAL

APPROVED:

Designed by:
Rhonda B. Early
F34CAFSAC8BF48A

DATE: 2/10/2015

TRANSPORTATION
MANAGEMENT PLAN

**FINAL PAVEMENT
MARKING PLANS**

4:24:58 PM \\p01\2514c_pmp.d21.dgn

REVISIONS

QA/QC STAGE:

REVIEW:

CONCUR:

REVISE:

VERIFY:

8/17/99

8/17/99

REVISIONS

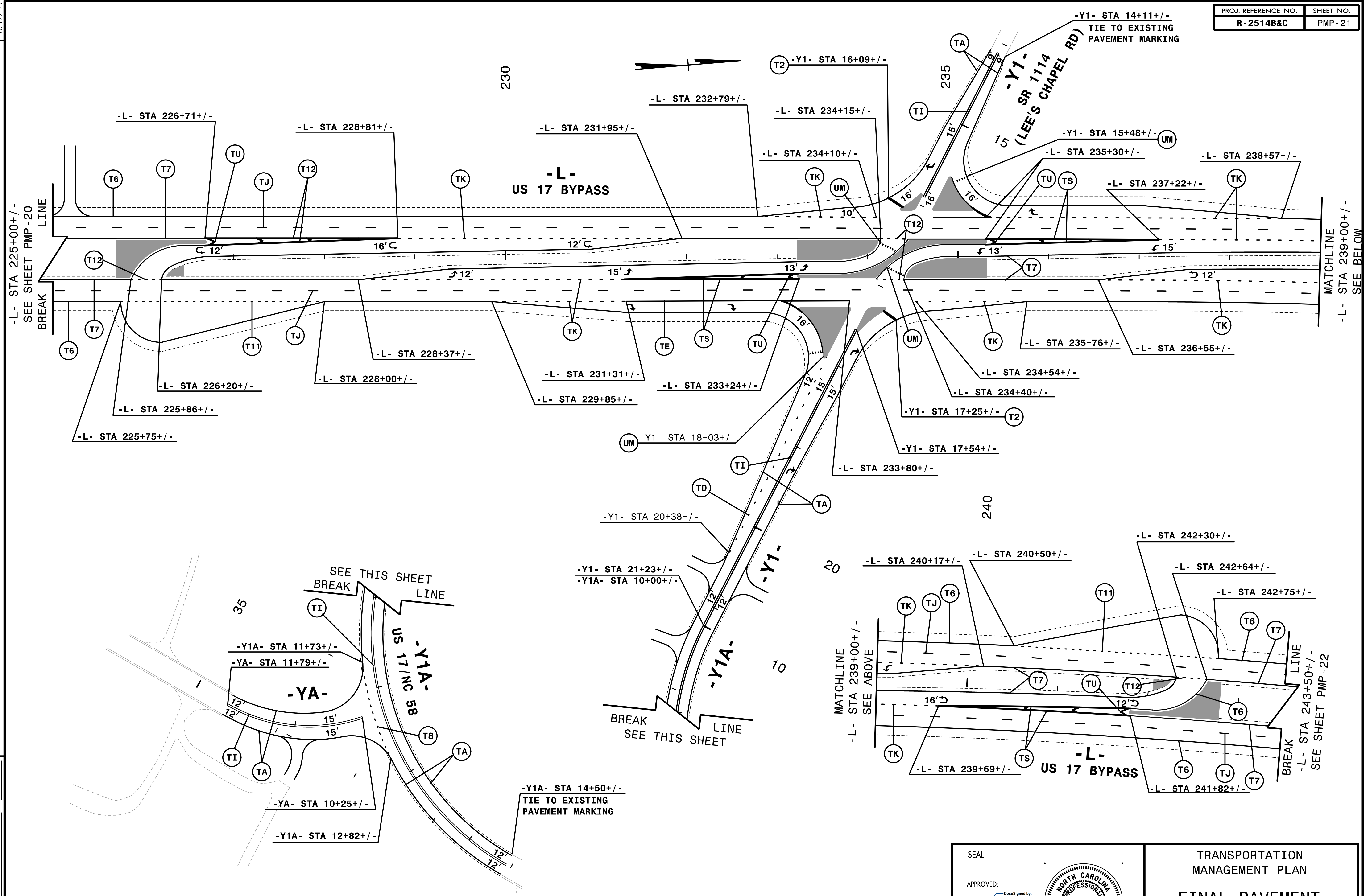

NOTE: ALL LANE WIDTHS ARE 12' UNLESS OTHERWISE SHOWN.

4:25:08 PM 2/10/2015 c:\pmp-d22.dgn
 \$\$\$\$USERNAME\$\$\$\$

QA/QC STAGE:
 REVIEW:
 CONCUR:
 REVISE:
 VERIFY:

HNTB HNTB NORTH CAROLINA, P.C.
 343 E. Six Forks Road, Suite 200
 Raleigh, North Carolina 27609
 NC License No: C-1554

SEAL
 APPROVED:
 Designated by:
 Rhonda B. Ealy
 F34CAFSACBFA8A.
 SEAL
 023521
 ENGINEER
 RHONDA B. EALY
 DATE: 2/10/2015

TRANSPORTATION
 MANAGEMENT PLAN
**FINAL PAVEMENT
 MARKING PLANS**

8/17/99

REVISIONS

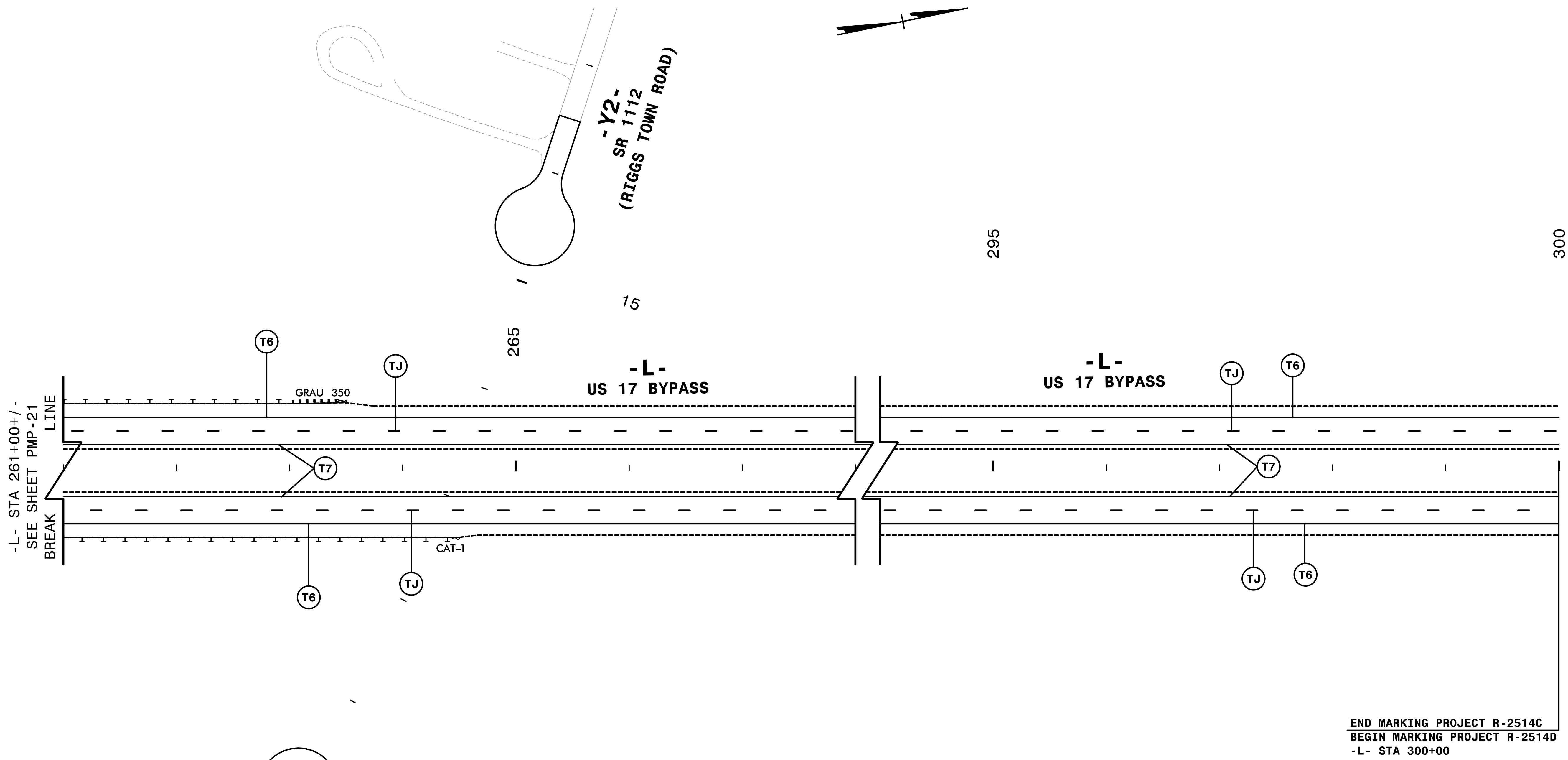

-L- STA 261+00+/-
 SEE SHEET PMP-21
 BREAK

END MARKING PROJECT R-2514C
 BEGIN MARKING PROJECT R-2514D
 -L- STA 300+00

-Y2-
 SR 1112
 (RIGGS TOWN ROAD)

NOTE: ALL LANE WIDTHS ARE 12' UNLESS OTHERWISE SHOWN.

4:\6\4\1\p\m\p\2514c.pmp.d23.dgn
 \$\$\$USE RANGE \$\$\$

Q/A/C STAGE:	
REVIEW:	
CONCUR:	
REVISE:	
VERIFY:	

HNTB HNTB NORTH CAROLINA, P.C.
 343 E. Six Forks Road, Suite 200
 Raleigh, North Carolina 27609
 NC License No: C-1554

SEAL

APPROVED: *Rhonda B. Early*
DESIGNED BY: Rhonda B. Early
 F34CAF5AC6BF48A...

DATE: 2/10/2015

TRANSPORTATION
 MANAGEMENT PLAN

**FINAL PAVEMENT
 MARKING PLANS**

8/17/99

REVISIONS

4:26:07 PM \\ms\p\2514b.pmp.d16.dgn
\$\$\$\$USERNAME\$\$\$\$

QA/QC STAGE:

REVIEW:	_____
CONCUR:	_____
REVISE:	_____
VERIFY:	_____

NOTE: ALL LANE WIDTHS ARE 12' UNLESS OTHERWISE SHOWN.

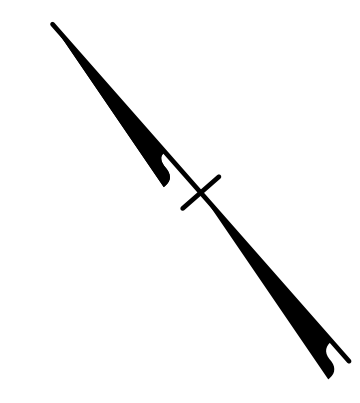
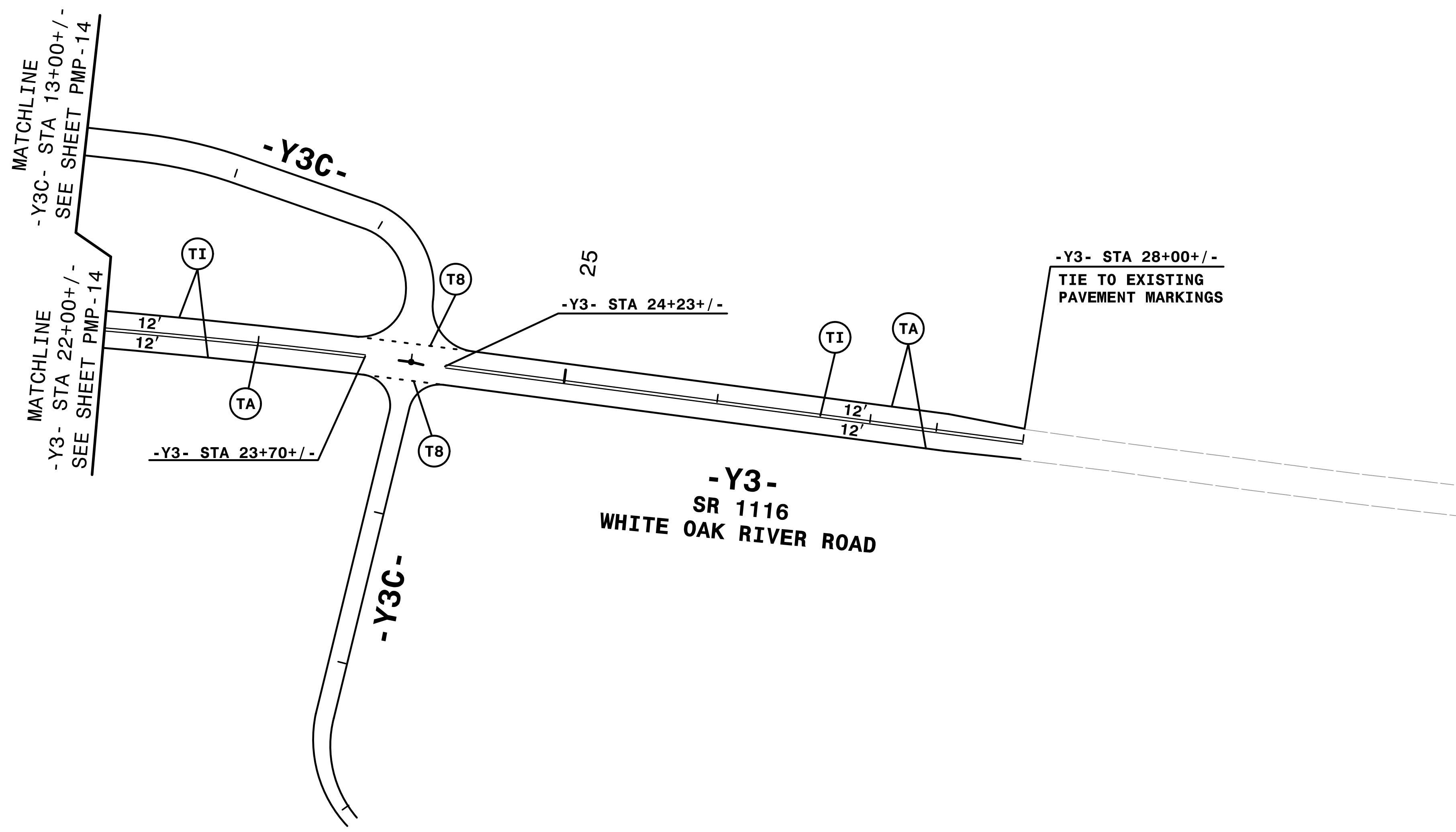

HNTB HNTB NORTH CAROLINA, P.C.
343 E. SIX FORKS ROAD, SUITE 200
RALEIGH, NORTH CAROLINA 27609
NC License No: C-1554

SEAL

APPROVED: *Rhonda B. Early*

Disc: Signed by: Rhonda B. Early
FS4CAF5AC68F48A...

DATE: 2/10/2015

TRANSPORTATION
MANAGEMENT PLAN

**FINAL PAVEMENT
MARKING PLANS**