

PAVEMENT SCHEDULE	
C1	1½" ASPHALT CONCRETE SURFACE COURSE, TYPE SF9.5A, AT AN AVERAGE RATE OF 165 LBS. PER SQ. YD.
C2	1½" ASPHALT CONCRETE SURFACE COURSE, TYPE S9.5B, AT AN AVERAGE RATE OF 168 LBS. PER SQ. YD.
D	2½" ASPHALT CONCRETE INTERMEDIATE COURSE, TYPE I19.0B, AT AN AVERAGE RATE OF 285 LBS. PER SQ. YD.
E	5½" ASPHALT CONCRETE BASE COURSE, TYPE B25.0B, AT AN AVERAGE RATE OF 627 LBS. PER SQ. YD.
F	#6M MAT COAT
T	AGGREGATE SHOULDER BORROW (SHOULDER RECONSTRUCTION AS DIRECTED BY THE ENGINEER)
U	EXISTING ASPHALT
V1	¾" MILLING
V2	2½" MILLING

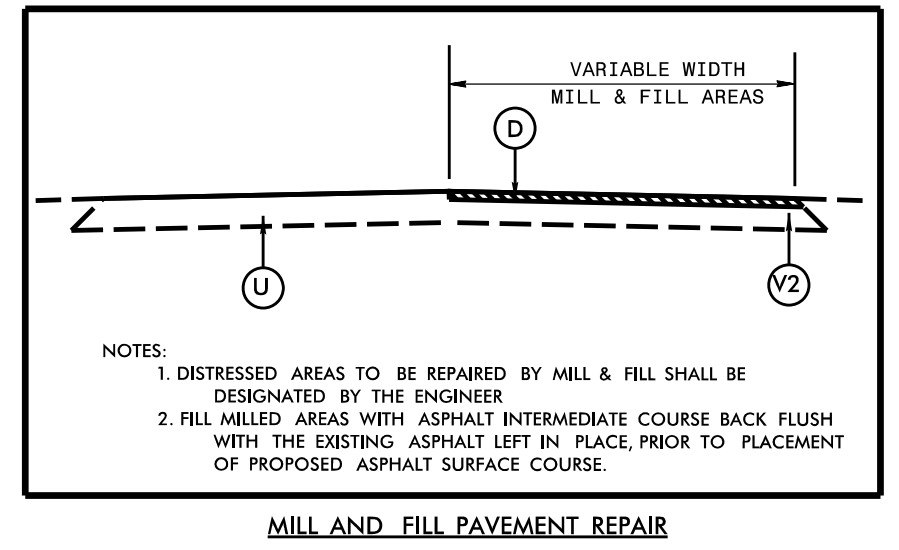
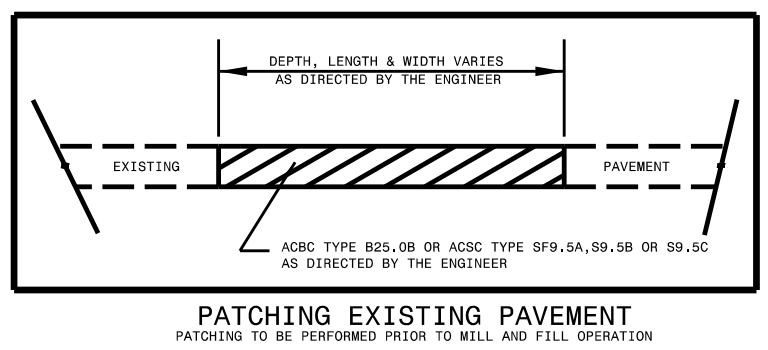
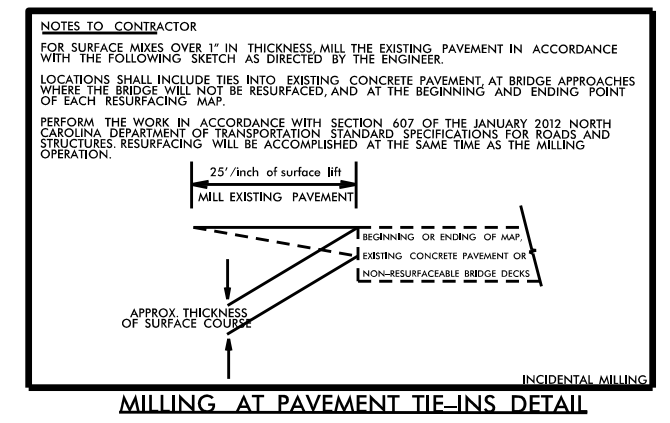
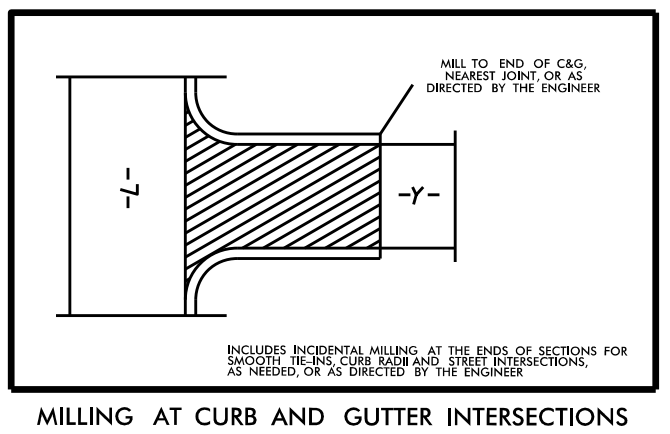
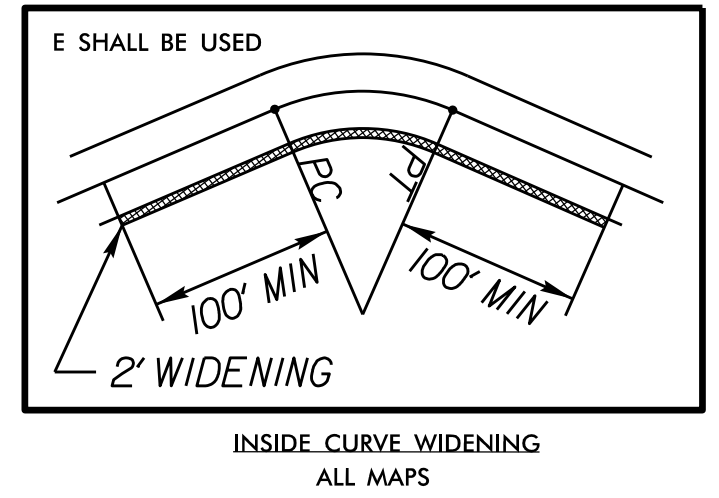
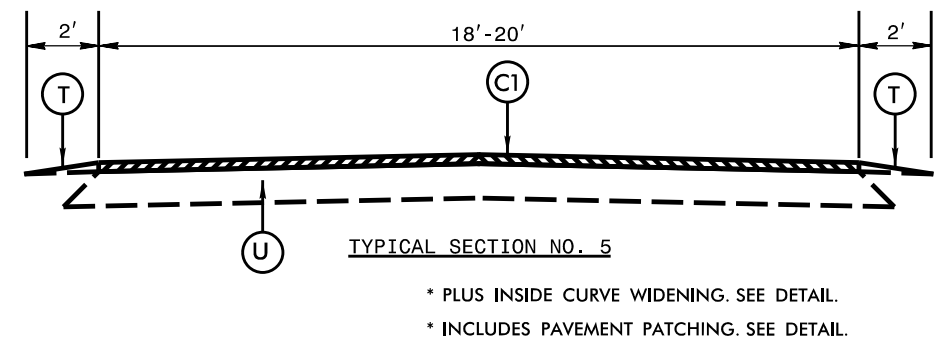
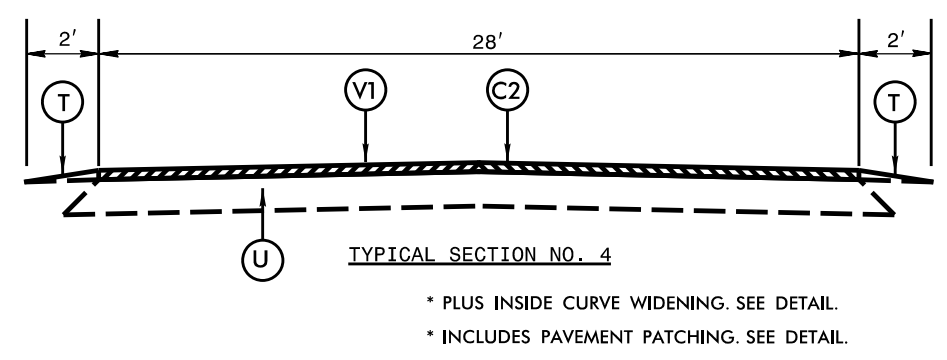
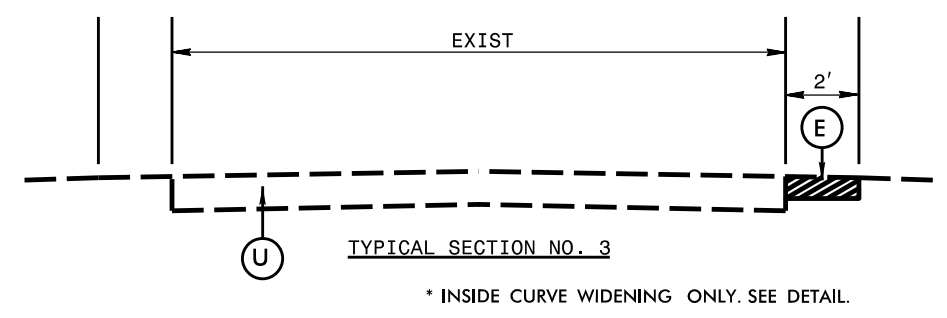
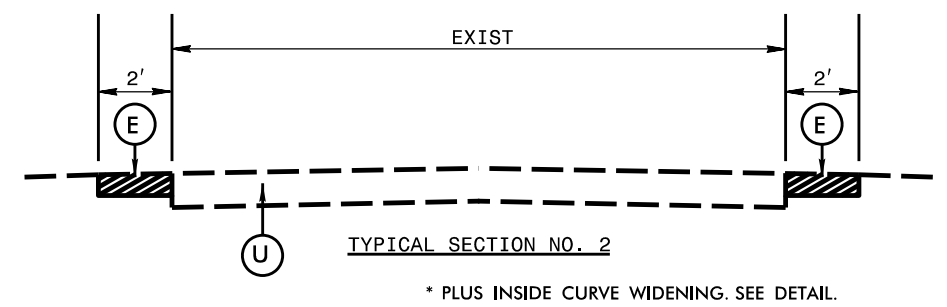
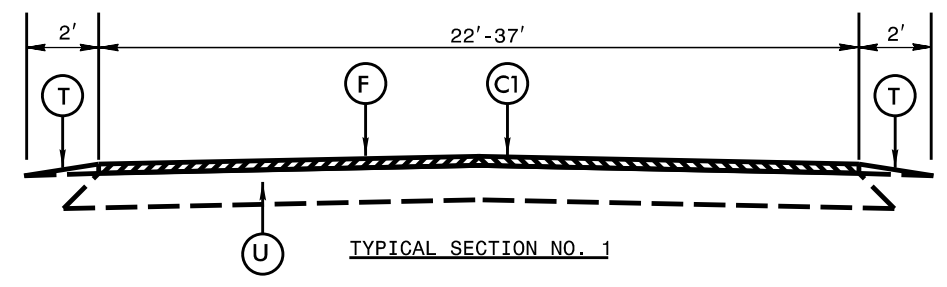

SYNTHETIC
LINES