

T.I.P.: R-2915D

**STATE OF NORTH CAROLINA
DEPARTMENT OF TRANSPORTATION**

PAVEMENT MARKING PLAN

LOCATION: US 221 FROM SOUTH OF NC 194
TO US 221 BYPASS

ASHE COUNTY

TIP NO. R-2915D	SHEET NO. PMP-1
<small>DocuSigned by:</small> <small>SCDCEAF8045AFA...</small>	
APPROVED: _____	
DATE: 10/29/2014	

BEGIN TIP PROJECT R-2915D

-L- STA 453+03.05 =

-TIE- STA 14+00.00

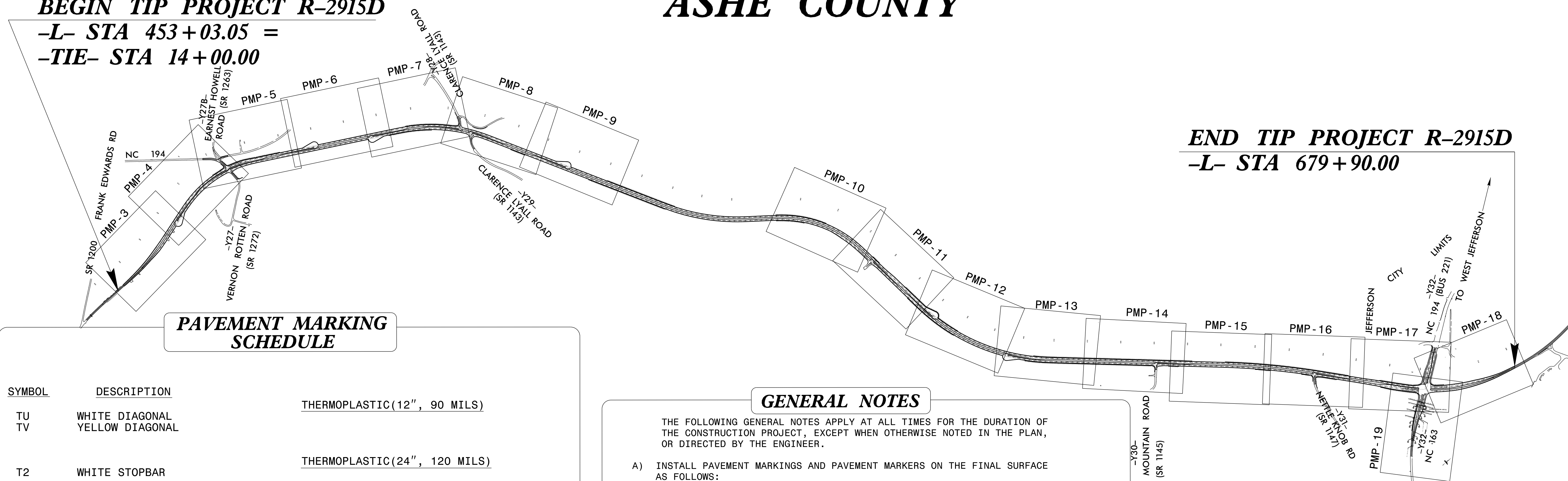

END TIP PROJECT R-2915D

-L- STA 679+90.00

PAVEMENT MARKING SCHEDULE

SYMBOL	DESCRIPTION	MATERIAL
TU	WHITE DIAGONAL	THERMOPLASTIC (12", 90 MILS)
TV	YELLOW DIAGONAL	
T2	WHITE STOPBAR	THERMOPLASTIC (24", 120 MILS)
V8	2 FT. - 6 FT./SP WHITE MINISKIP	POLYUREA (4")
V9	2 FT. - 6 FT./SP YELLOW MINISKIP	
VA	WHITE EDGELINE	
VB	YELLOW EDGELINE	
VC	10 FT. WHITE SKIP	
VD	3 FT. - 9 FT./SP WHITE MINISKIP	
VE	WHITE SOLID LANE LINE	
VI	YELLOW DOUBLE CENTER	POLYUREA (8")
VN	WHITE GORELINE	THERMOPLASTIC PAVEMENT MARKING CHARACTER (120 MILS)
UI	ALPHANUMERIC CHAR.	THERMOPLASTIC PAVEMENT MARKING SYMBOLS (90 MILS)
UA	LEFT TURN ARROW	SNOWPLOWABLE RAISED PAVEMENT MARKERS
UB	RIGHT TURN ARROW	
UC	STRAIGHT ARROW	
UE	COMBO. STRAIGHT/RIGHT	
UP	MERGE ARROW	
UT	U-TURN ARROW	
ME	YELLOW & YELLOW	SNOWPLOWABLE RAISED PAVEMENT MARKERS
MF	CRYSTAL & RED	

GENERAL NOTES

- THE FOLLOWING GENERAL NOTES APPLY AT ALL TIMES FOR THE DURATION OF THE CONSTRUCTION PROJECT, EXCEPT WHEN OTHERWISE NOTED IN THE PLAN, OR DIRECTED BY THE ENGINEER.
- INSTALL PAVEMENT MARKINGS AND PAVEMENT MARKERS ON THE FINAL SURFACE AS FOLLOWS:

ROAD NAME	MARKING	MARKER
US HWY 221/NC HWY 194 & -Y- LINES	POLYUREA	SNOWPLOWABLE RAISED
 - TIE PROPOSED PAVEMENT MARKING LINES TO EXISTING PAVEMENT MARKING LINES.
 - REMOVE/REPLACE ANY CONFLICTING/DAMAGED PAVEMENT MARKINGS AND MARKERS.
 - PASSING ZONES WILL BE DETERMINED IN THE FIELD AND MUST BE APPROVED BY THE ENGINEER.
 - STOP BAR LOCATION AT NON-SIGNALIZED INTERSECTIONS MAY BE ADJUSTED AS DIRECTED BY THE ENGINEER.
 - UNLESS OTHERWISE SPECIFIED, HEATED-IN-PLACE THERMOPLASTIC MAY BE USED IN LIEU OF EXTRUDED THERMOPLASTIC FOR STOP BARS, SYMBOLS, CHARACTERS AND DIAGONALS. IF HEATED-IN-PLACE IS USED, IT SHALL BE PAID FOR USING THE EXTRUDED THERMOPLASTIC PAY ITEM.

PLAN PREPARED BY: SEPI ENGINEERING & CONSTRUCTION

JOSEPH B. KOPASKIE, PE SIGNING & DELINEATION PROJECT ENGINEER
RICHARD DRAYTON SIGNING & DELINEATION PROJECT DESIGN ENGINEER

NCDOT CONTACTS:

KELVIN L. JORDAN SIGNING & DELINEATION REGIONAL ENGINEER
DERRICK H. BEARD SIGNING & DELINEATION PROJECT DESIGN ENGINEER

ROADWAY STANDARD DRAWING

THE FOLLOWING ROADWAY STANDARDS AS APPEAR IN "ROADWAY STANDARD DRAWINGS" - PROJECT SERVICES UNIT - N.C. DEPARTMENT OF TRANSPORTATION - RALEIGH, N.C., DATED JANUARY 2012 ARE APPLICABLE TO THIS PROJECT AND BY REFERENCE HEREBY ARE CONSIDERED A PART OF THESE PLANS:

STD. NO.	TITLE
1205.01	PAVEMENT MARKINGS - LINE TYPES AND OFFSETS
1205.02	PAVEMENT MARKINGS - TWO-LANE AND MULTILANE ROADWAYS
1205.04	PAVEMENT MARKINGS - INTERSECTIONS
1205.05	PAVEMENT MARKINGS - TURN LANES
1205.08	PAVEMENT MARKINGS - SYMBOLS AND WORD MESSAGES
1205.09	PAVEMENT MARKINGS - PAINTED ISLANDS
1205.10	PAVEMENT MARKINGS - SCHOOL AREAS
1205.13	PAVEMENT MARKINGS - LANE REDUCTIONS
1250.01	RAISED PAVEMENT MARKERS - INSTALLATION SPACING
1253.01	RAISED PAVEMENT MARKERS - SNOWPLOWABLE
1261.01	GUARDRAIL AND BARRIER DELINEATORS - INSTALLATION SPACING
1261.02	GUARDRAIL AND BARRIER DELINEATORS - TYPES AND MOUNTING
1262.01	GUARDRAIL END DELINEATION

INDEX

SHEET NO.	DESCRIPTION
PMP-1	PAVEMENT MARKING PLAN TITLE, SCHEDULE, NOTES AND RSD SCHEDULE SHEET
PMP-2	REVISED PAVEMENT MARKING ROADWAY STANDARD DRAWING DETAIL
PMP-3-19	PAVEMENT MARKING DETAIL

STATE OF NORTH CAROLINA
 DEPT. OF TRANSPORTATION
 DIVISION OF HIGHWAYS
 RALEIGH, N.C.

ENGLISH DETAIL DRAWING FOR
PAVEMENT MARKINGS
 SYMBOLS AND WORD MESSAGES

SHEET 3 OF 8
1205D08

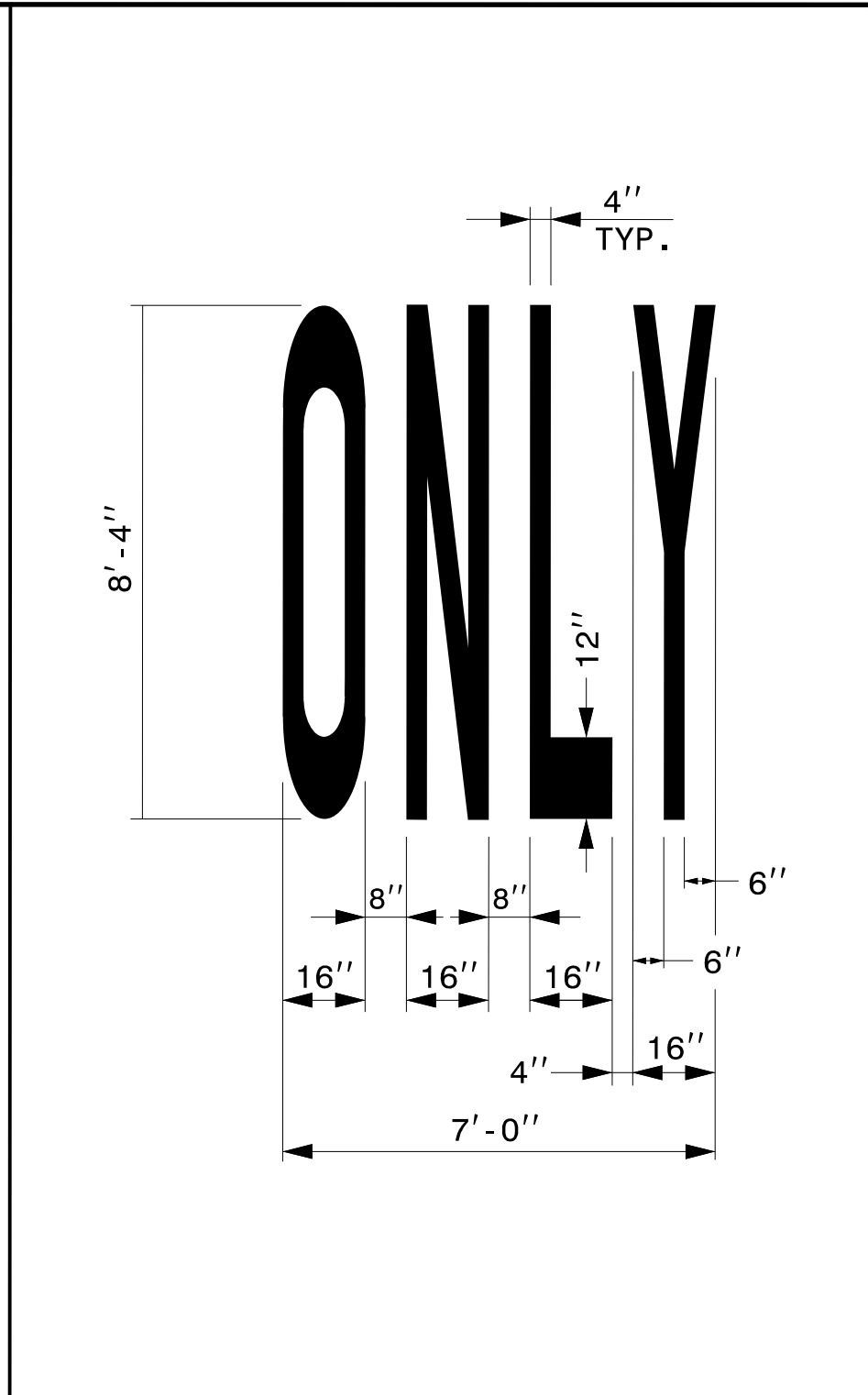
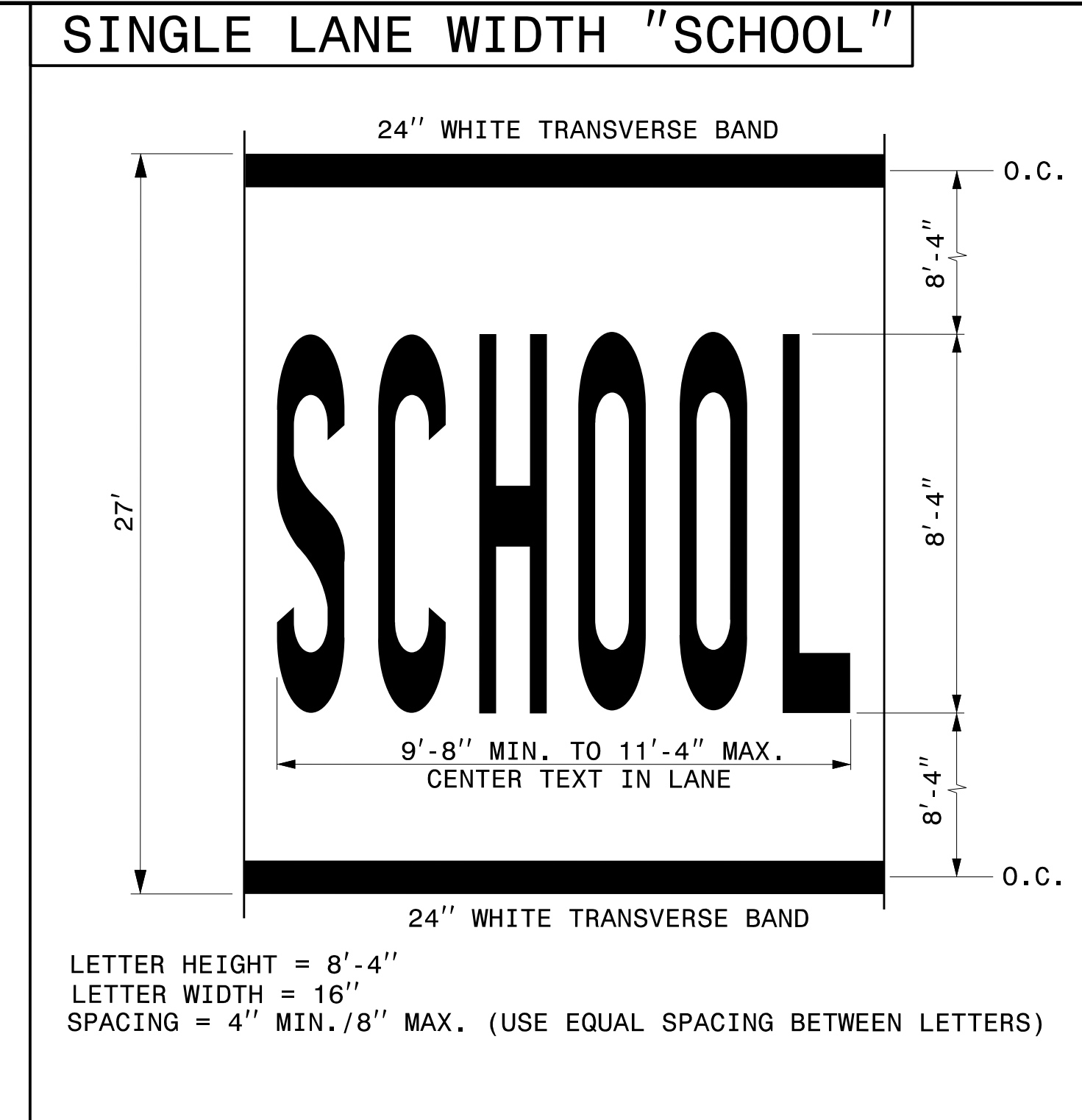
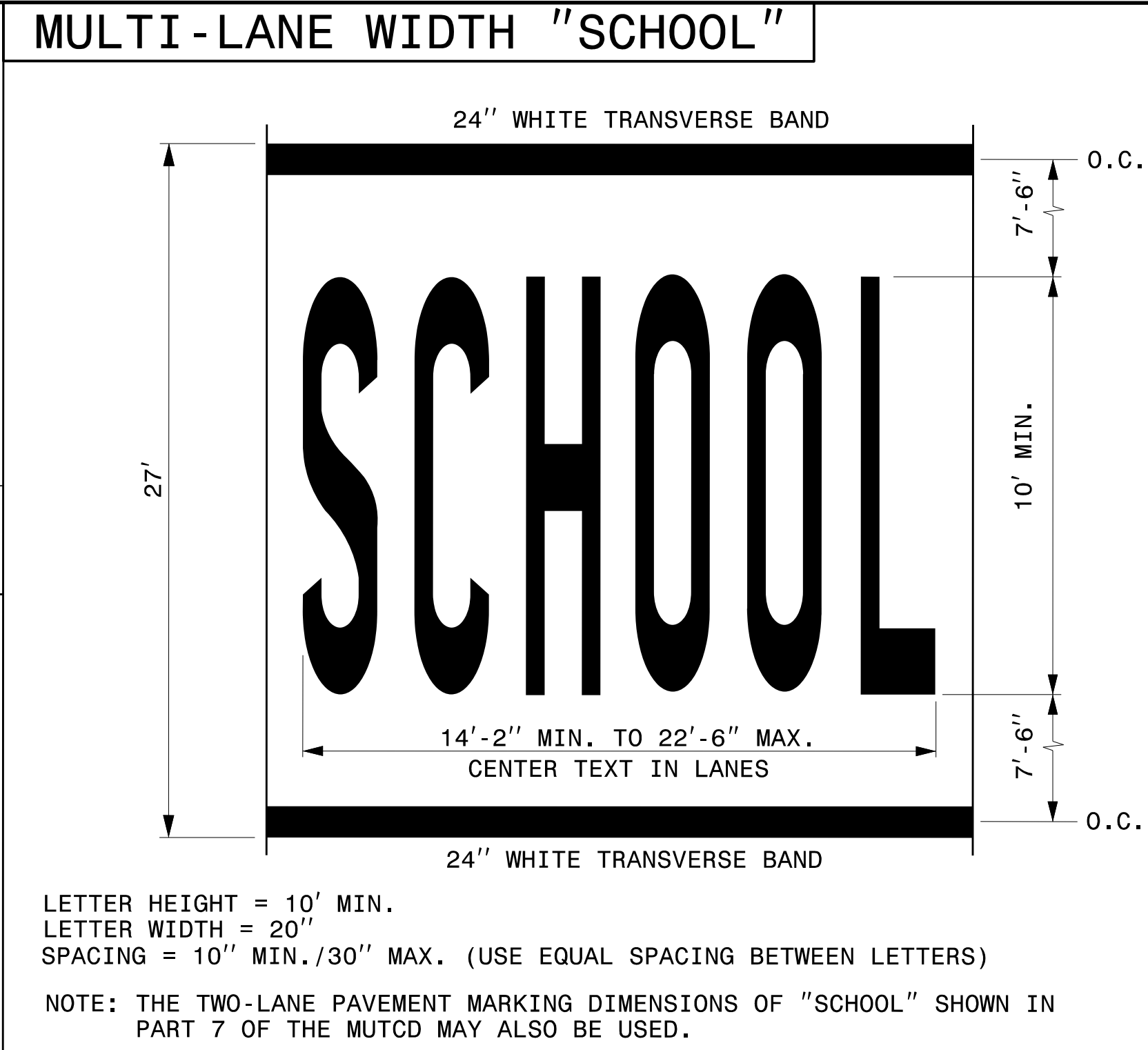

STATE OF NORTH CAROLINA
 DEPT. OF TRANSPORTATION
 DIVISION OF HIGHWAYS
 RALEIGH, N.C.

ENGLISH DETAIL DRAWING FOR
PAVEMENT MARKINGS
 SYMBOLS AND WORD MESSAGES

SHEET 3 OF 8
1205D08

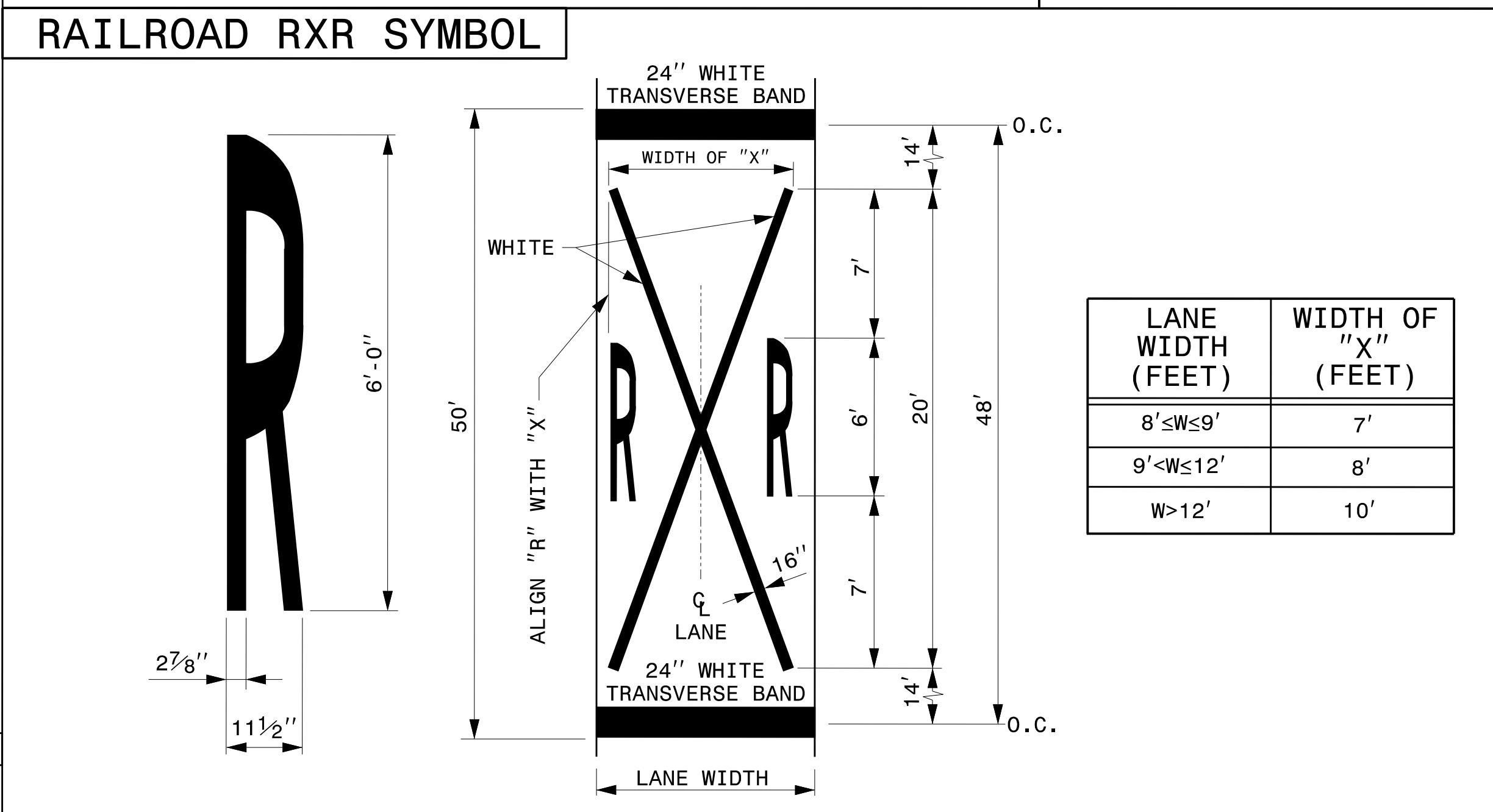

GENERAL NOTES:

- THE SCHOOL PAVEMENT MARKING CONSISTS OF SIX (6) CHARACTERS. THE TWO (2) 24" TRANSVERSE BANDS WILL BE PAID FOR UNDER A SEPARATE PAY ITEM. REFER TO ROADWAY STANDARD DRAWING 1205.10 FOR ADDITIONAL PAVEMENT MARKING GUIDANCE.
- PAVEMENT MARKING IN ADVANCE OF A HIGHWAY-RAIL CROSSING SHALL CONSIST OF TWO (2) CHARACTERS AND TWO (2) 16" LINES (FORMING AN X) WHICH ARE PAID FOR UNDER TWO SEPARATE PAY ITEMS. THE TWO (2) 24" TRANSVERSE BANDS WILL BE PAID FOR UNDER A SEPARATE PAY ITEM. REFER TO ROADWAY STANDARD DRAWING 1205.11 FOR ADDITIONAL PAVEMENT MARKING GUIDANCE.

10/28/2014
 P:\Traffic\Signing\CADD\Signing Layout Plans\Additional Sheets.dgn
 User: walter-johnson

TIP NO. R-2915D	SHEET NO. PMP-3
Approved by: <u>Joseph B. Kopaskie</u> <small>SC02EAEF90A54FA</small>	
DATE: 10/29/2014	
SEAL	
	

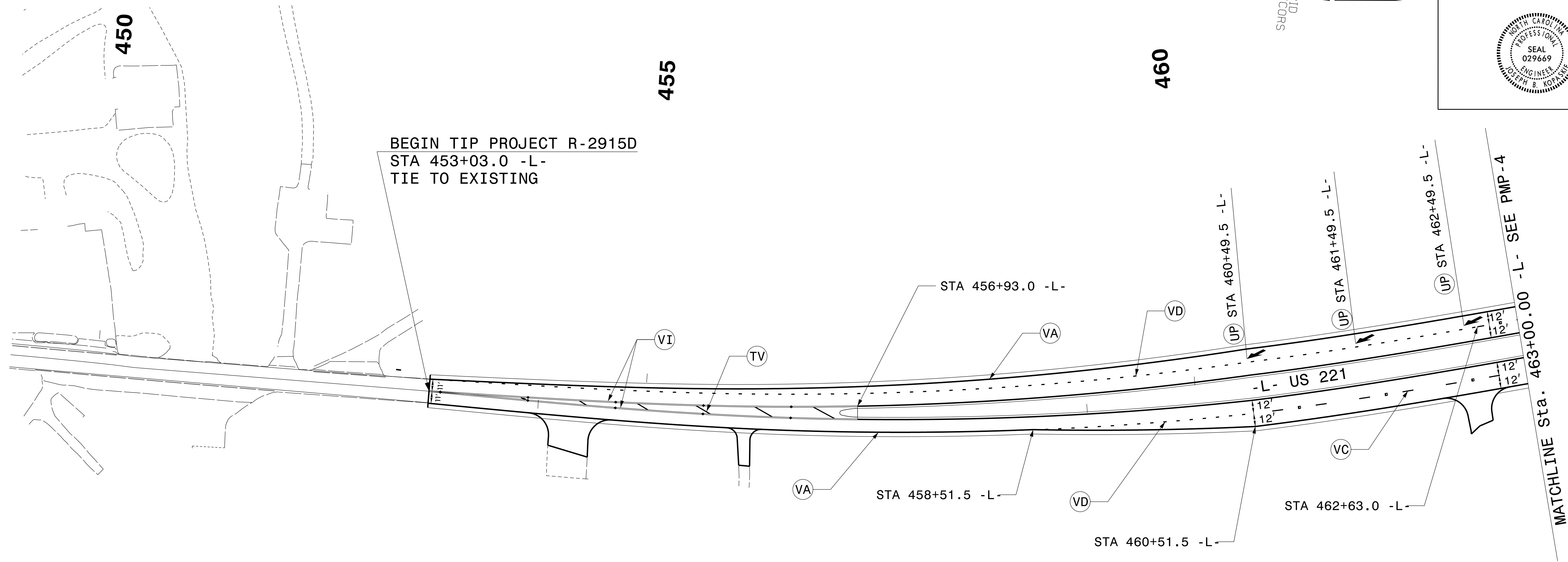
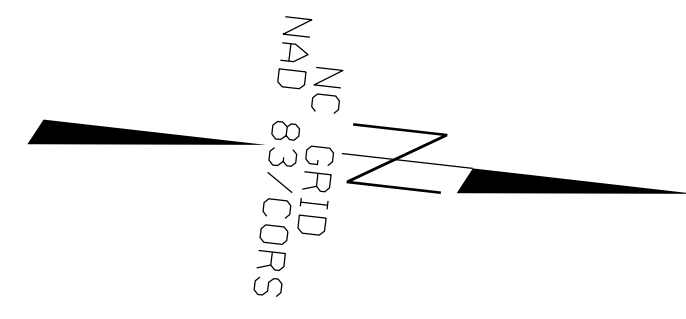

BEGIN TIP PROJECT R-2915D
 STA 453+03.0 -L-
 TIE TO EXISTING

PAVEMENT MARKING DETAIL

SYTIME
 CONSTRUCTION
 USERNAME

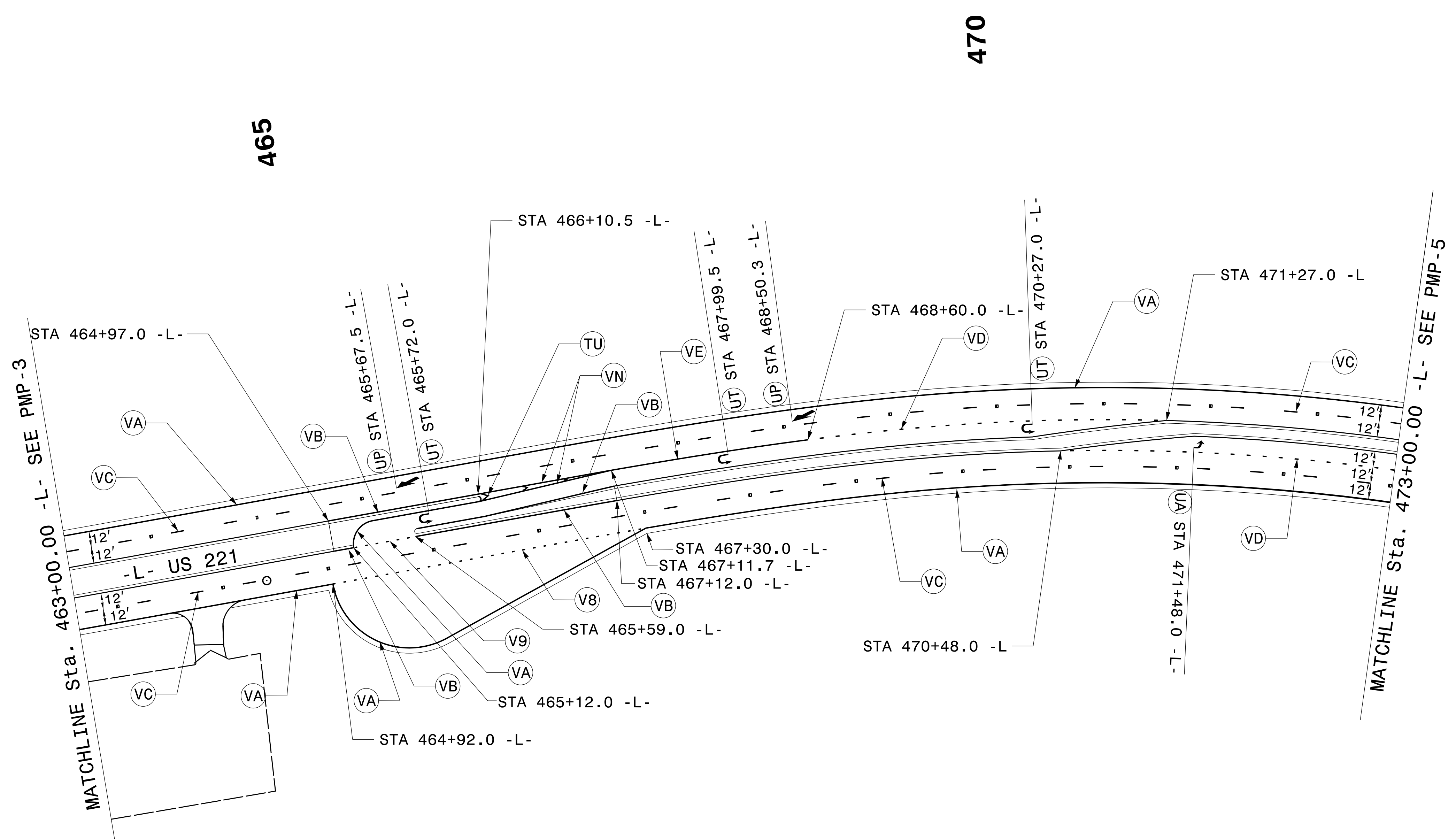
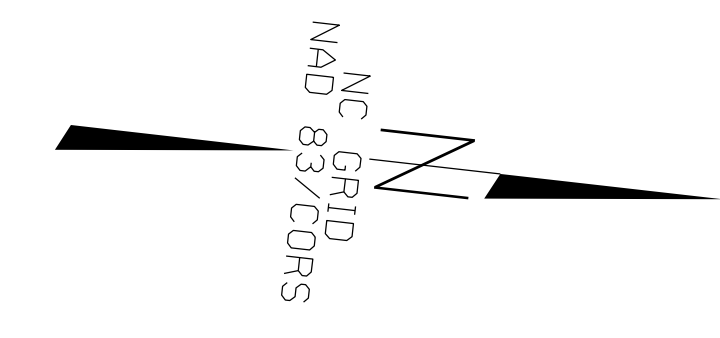

465

470

MATCHLINE Sta. 463+00.00 -L- SEE PMP-3

MATCHLINE Sta. 473+00.00 -L- SEE PMP-5

-L- US 221

PAVEMENT MARKING DETAIL

SYTIME
 CONSTRUCTION
 USERNAME

TIP NO. R-2915D	SHEET NO. PMP-6
APPROVED: <u>Joseph B. Kopaska</u> <small>SC026AEFB0484FA</small>	
DATE: 10/29/2014	
SEAL	

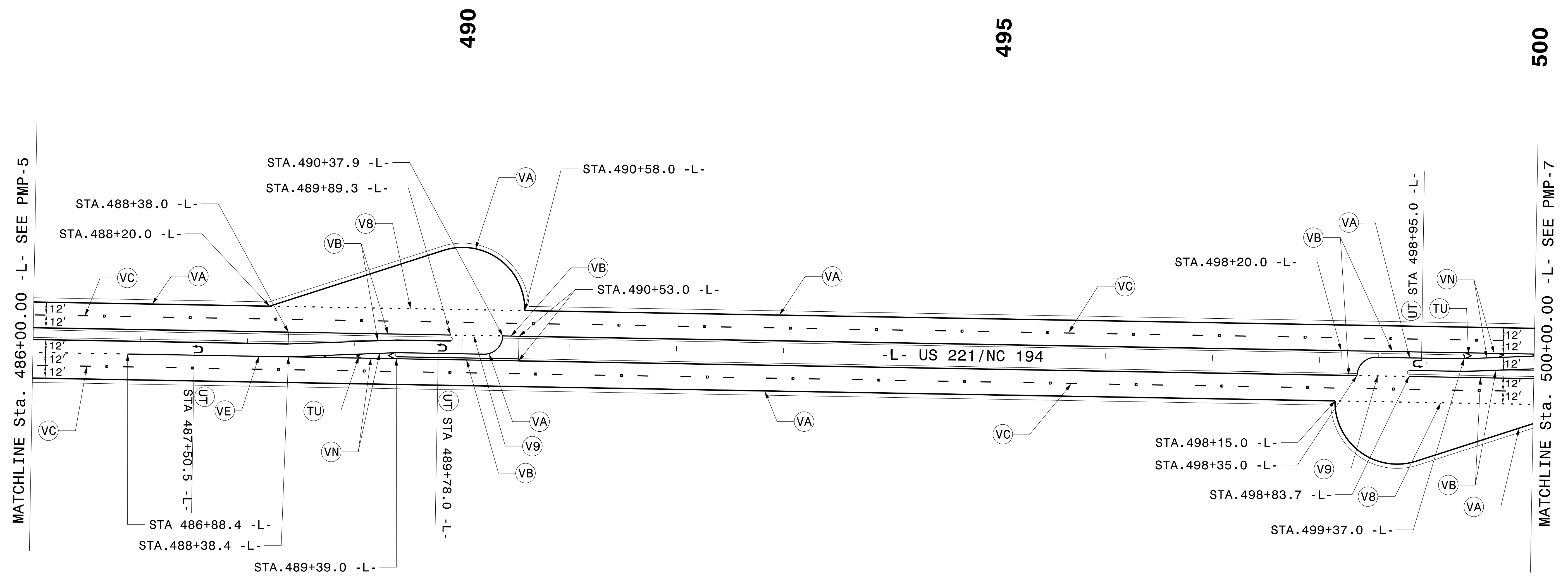
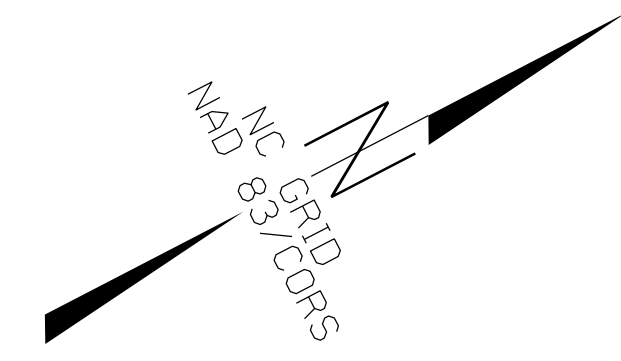

PAVEMENT MARKING DETAIL

\$\$\$\$\$\$SYTIME\$\$\$\$\$\$
 \$\$\$\$\$\$CONDN\$\$\$\$\$\$
 \$\$\$\$\$\$DUSERNAME\$\$\$\$\$\$
 \$\$\$\$\$\$\$\$\$\$\$\$

TIP NO. R-2915D	SHEET NO. PMP-7
APPROVED: <u>Joseph B. Kopaskie</u> <small>SC026AEF80A5FA</small>	
DATE: <u>10/29/2014</u>	
SEAL	

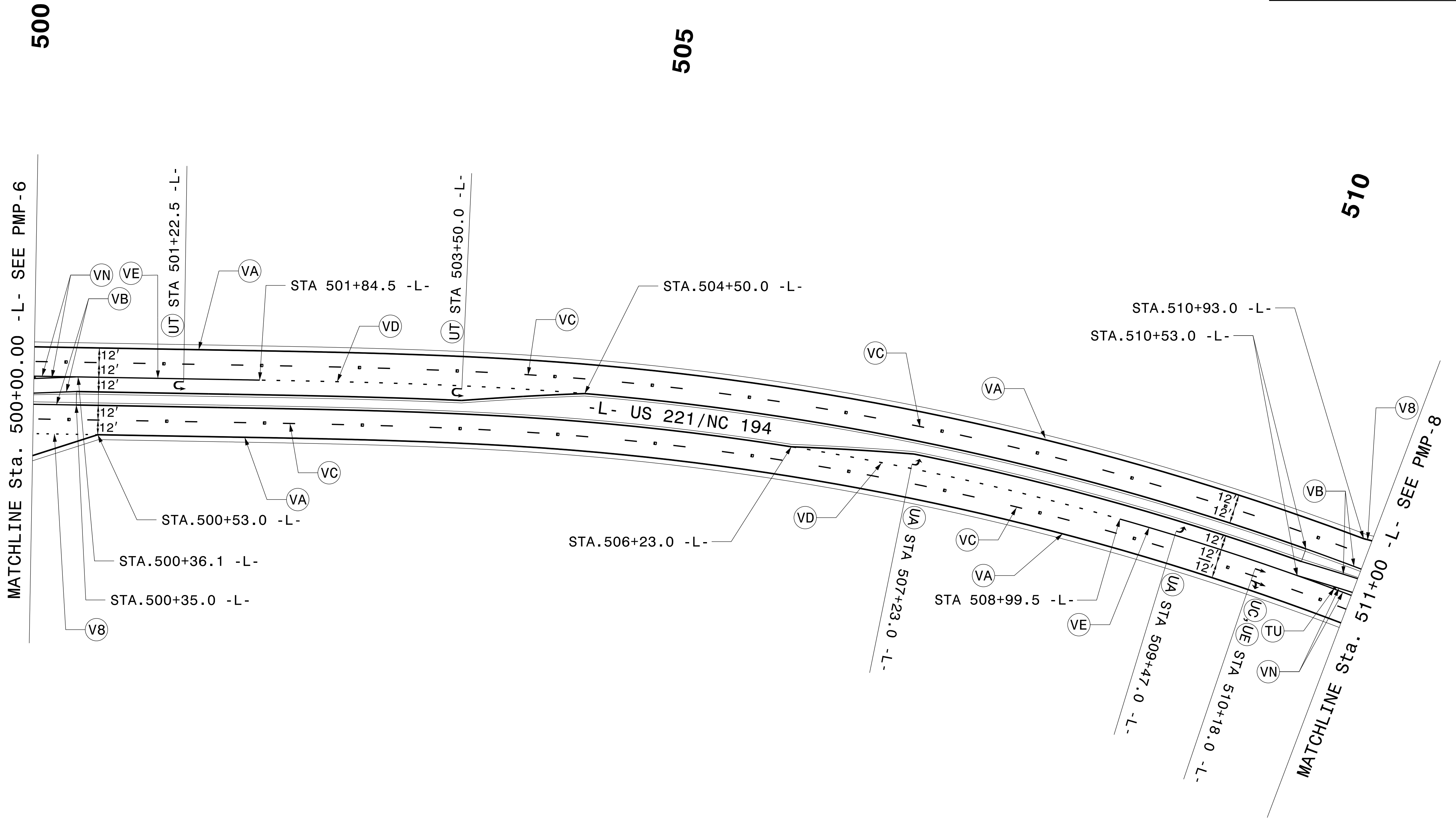
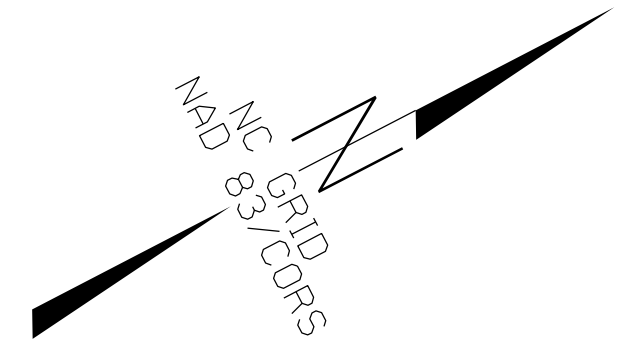
500

505

510

MATCHLINE Sta. 500+00.00 -L- SEE PMP-6

MATCHLINE Sta. 511+00 -L- SEE PMP-8

PAVEMENT MARKING DETAIL

SYTIME
D:\USER\KME
\$\$\$\$\$

TIP NO. R-2915D	SHEET NO. PMP-8
Approved by: <u>Joseph B. Kopasnik</u> <small>00DREAEPB0454FA</small>	
DATE: 10/29/2014	
SEAL	

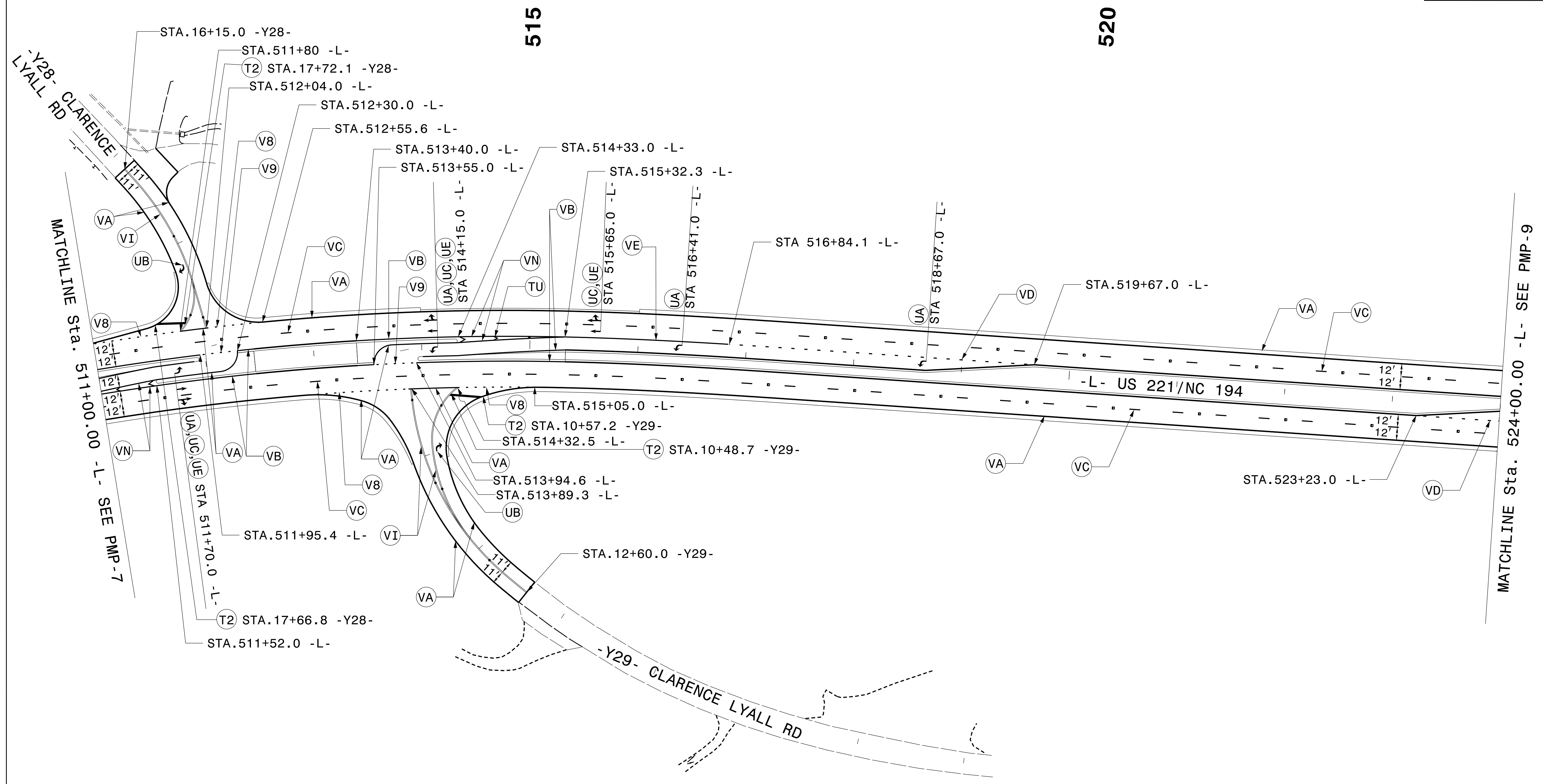
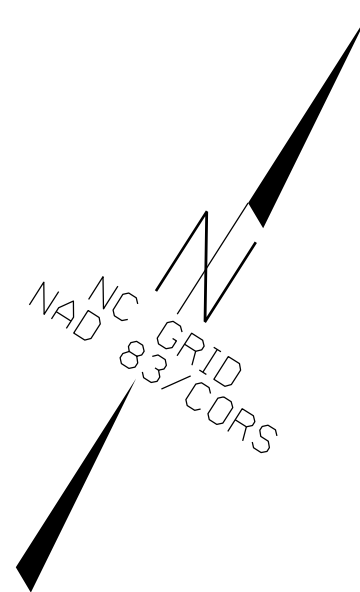

PAVEMENT MARKING DETAIL

SYTIME
COND
DUSERNAME

TIP NO. R-2915D	SHEET NO. PMP-9
APPROVED: <u>Joseph B. Kopaska</u> <small>SC026AEFB0484FA</small>	
DATE: <u>10/29/2014</u>	
SEAL	

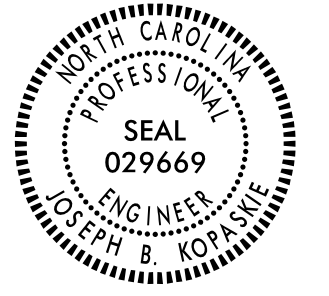
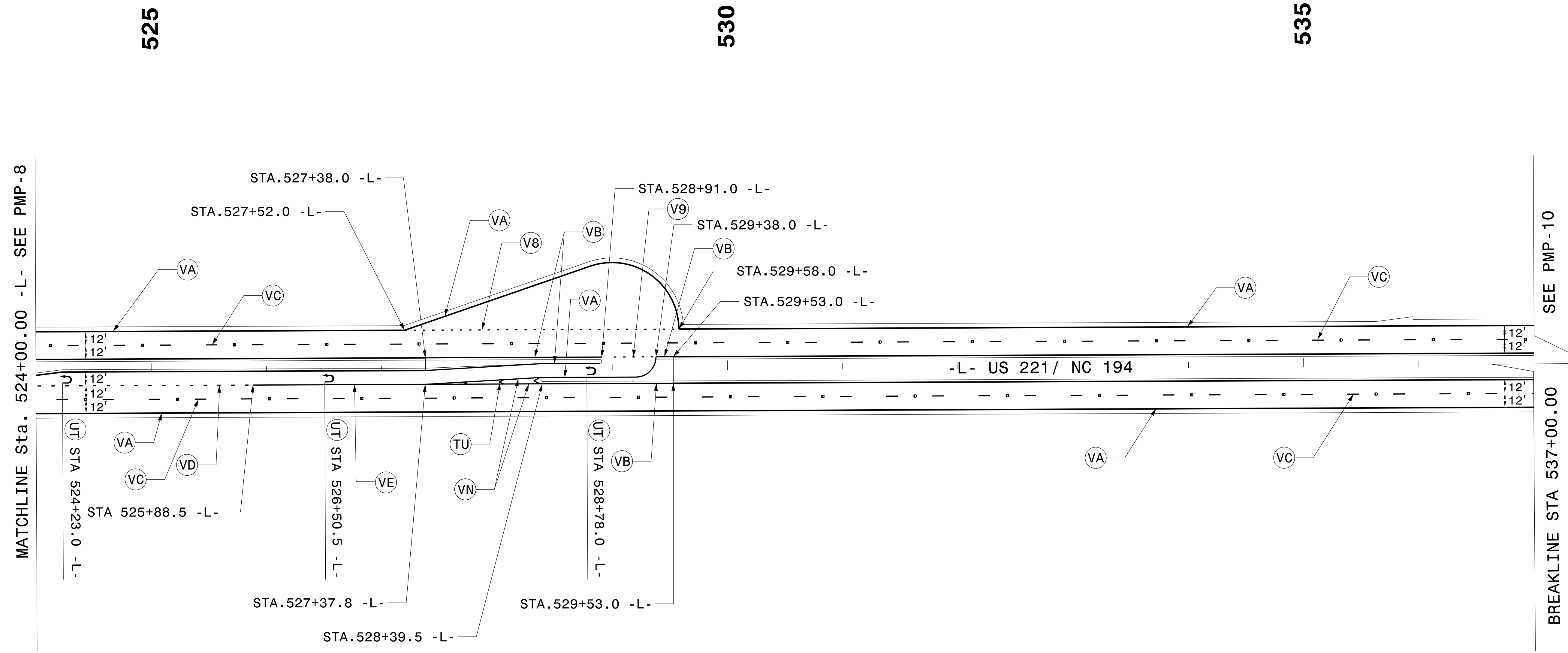
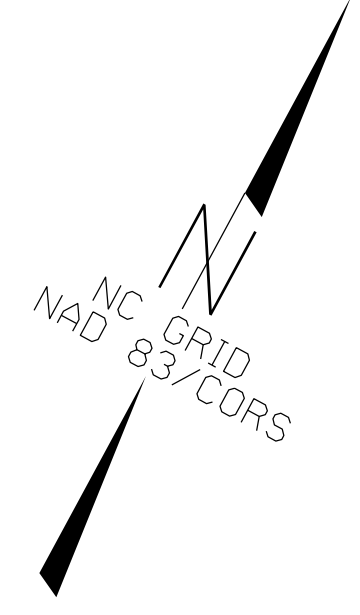
PAVEMENT MARKING DETAIL

SYTIME\$\$\$\$
CONDN\$\$\$\$
DUSERNAME\$\$\$\$
\$\$\$\$

TIP NO. R-2915D	SHEET NO. PMP-10
APPROVED: <u>Joseph B. Kopaska</u> <small>SC0204EAF80A84FA</small>	
DATE: 10/29/2014	
SEAL	

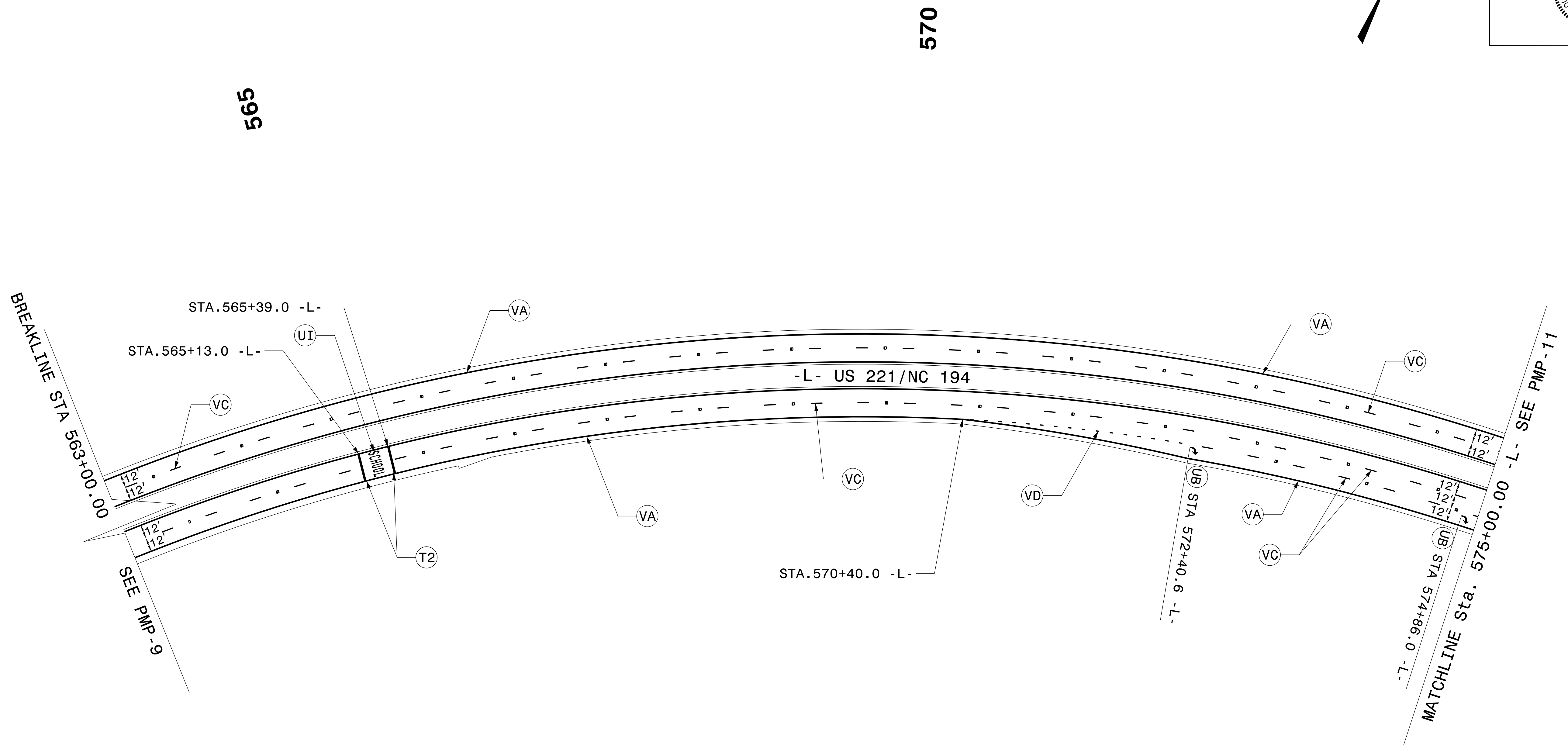

PAVEMENT MARKING DETAIL

SYTIME
 CON
 USER
 DLSERNAME
 \$\$\$\$\$\$

TIP NO. R-2915D	SHEET NO. PMP-11
Approved by: <i>Joseph B. Kopaschke</i> <small>PCDREAEF80454FA</small>	
DATE: 10/29/2014	
SEAL	

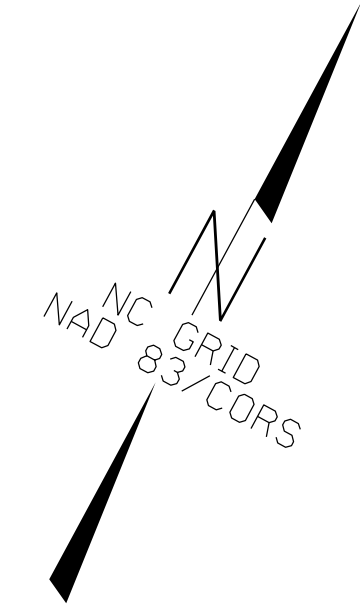

575

580

585

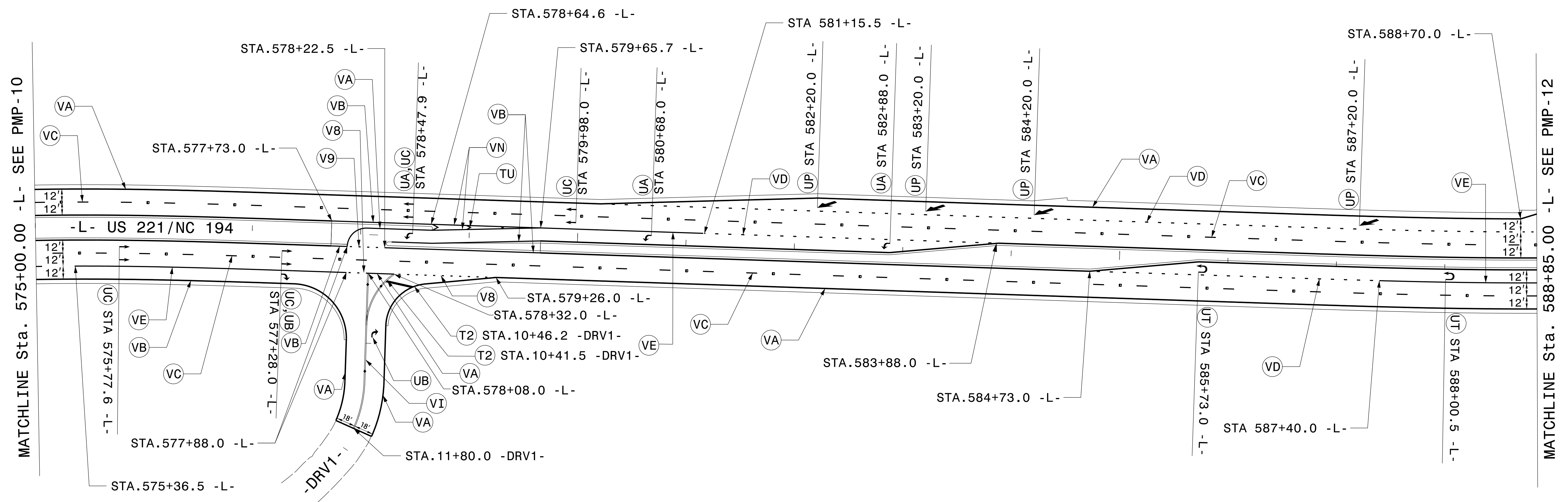

PAVEMENT MARKING DETAIL

SYTIME
 D:\USER\NAME
 \$\$\$

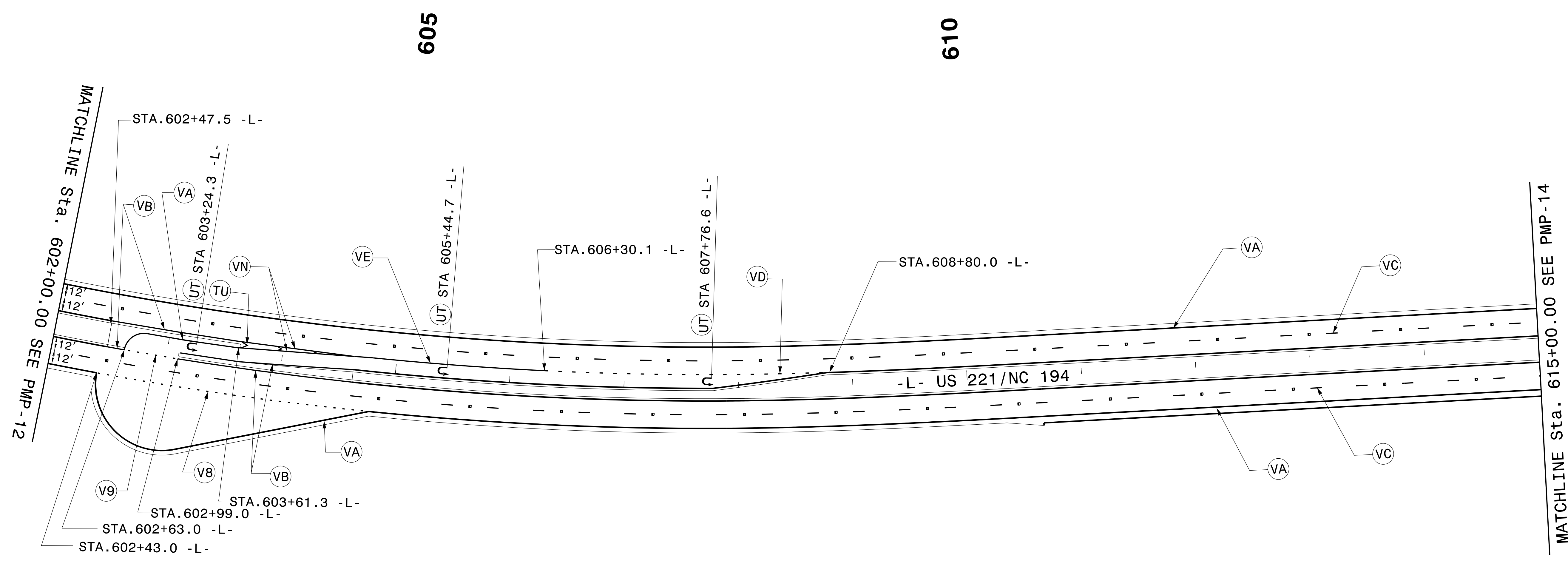
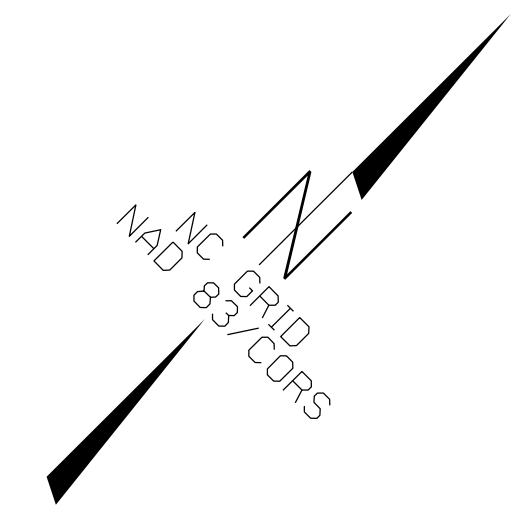

PAVEMENT MARKING DETAIL

\$\$\$
 TIME
 USER
 \$\$\$

TIP NO. R-2915D	SHEET NO. PMP-18
Approved by: <u>Joseph B. Kopaskie</u> <small>BCD9EAEFB0A54FA...</small>	
DATE: 10/29/2014	
SEAL	

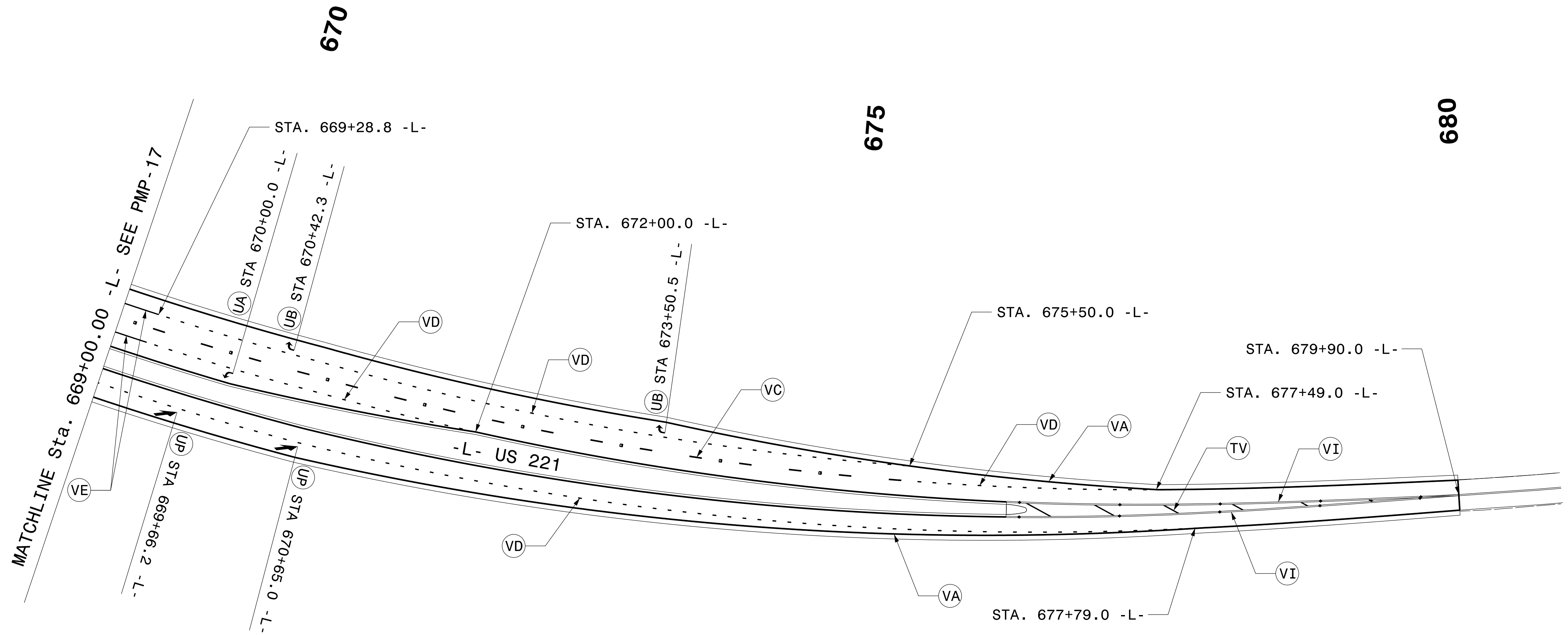
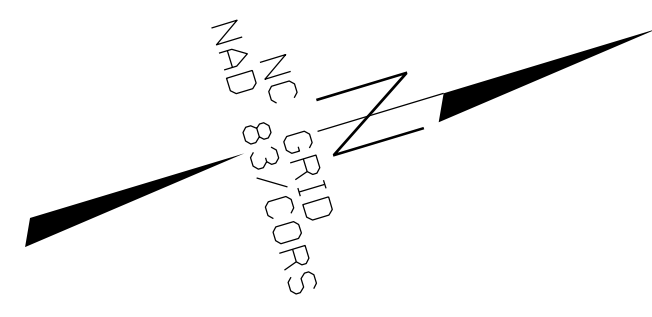

SYTIME
 CON
 USERNAME
 \$\$\$\$\$\$

PAVEMENT MARKING DETAIL

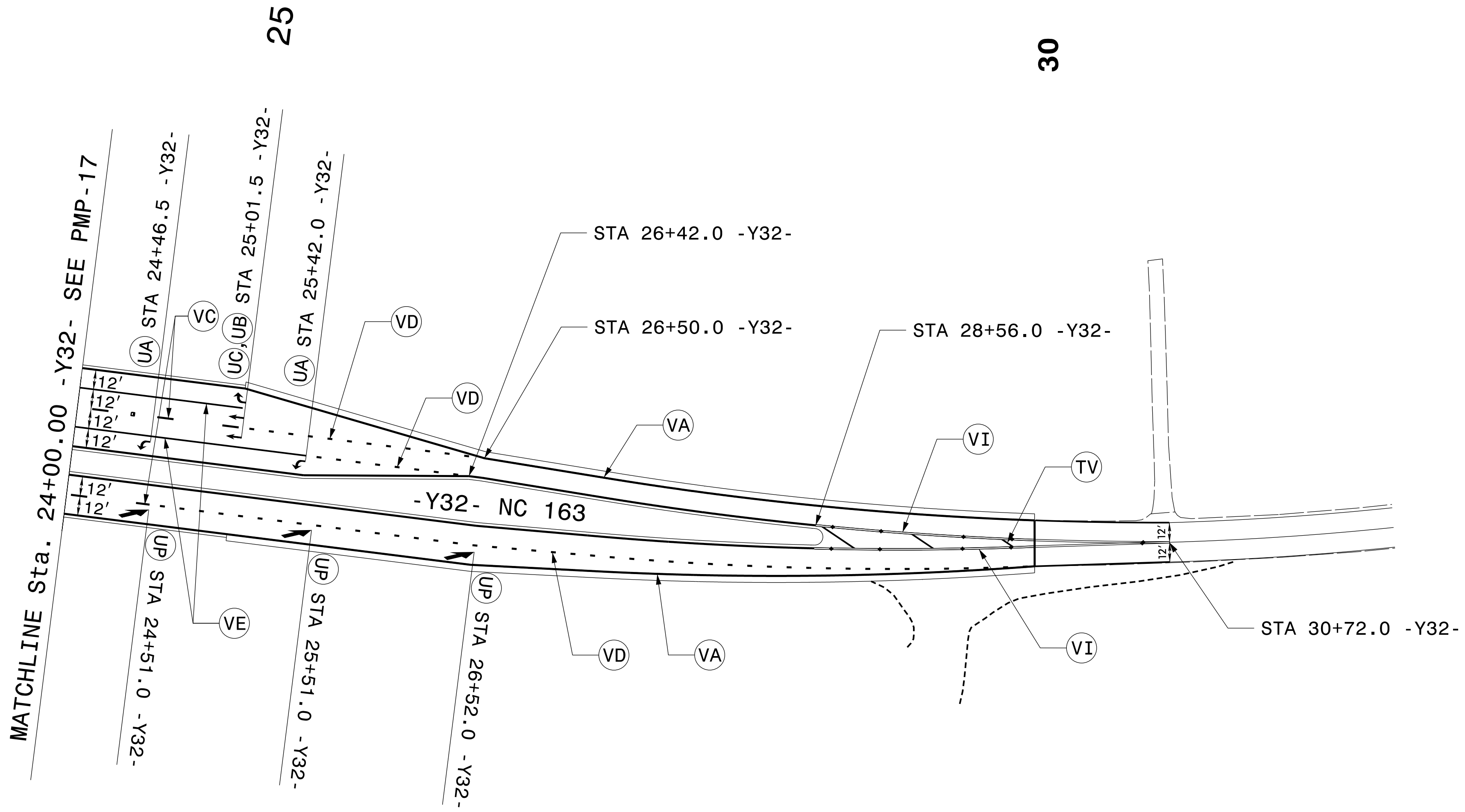
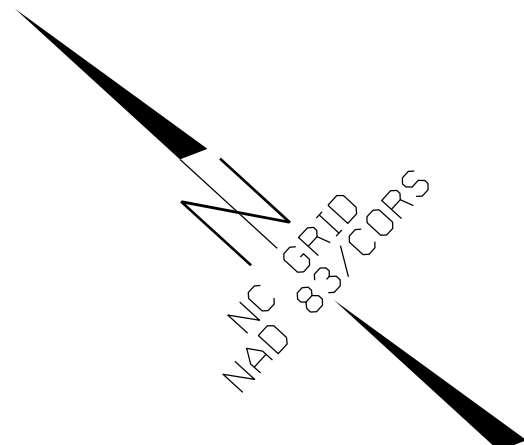

PAVEMENT MARKING DETAIL

SYTIME
COND
DUSERNAME
\$\$\$\$\$