

TIP NO. R-2915D	SHEET NO. PMP-6
APPROVED: <i>Joseph B. Kopaska</i> <small>SC0284EAF80A84FA</small>	
DATE: 10/29/2014	
SEAL	

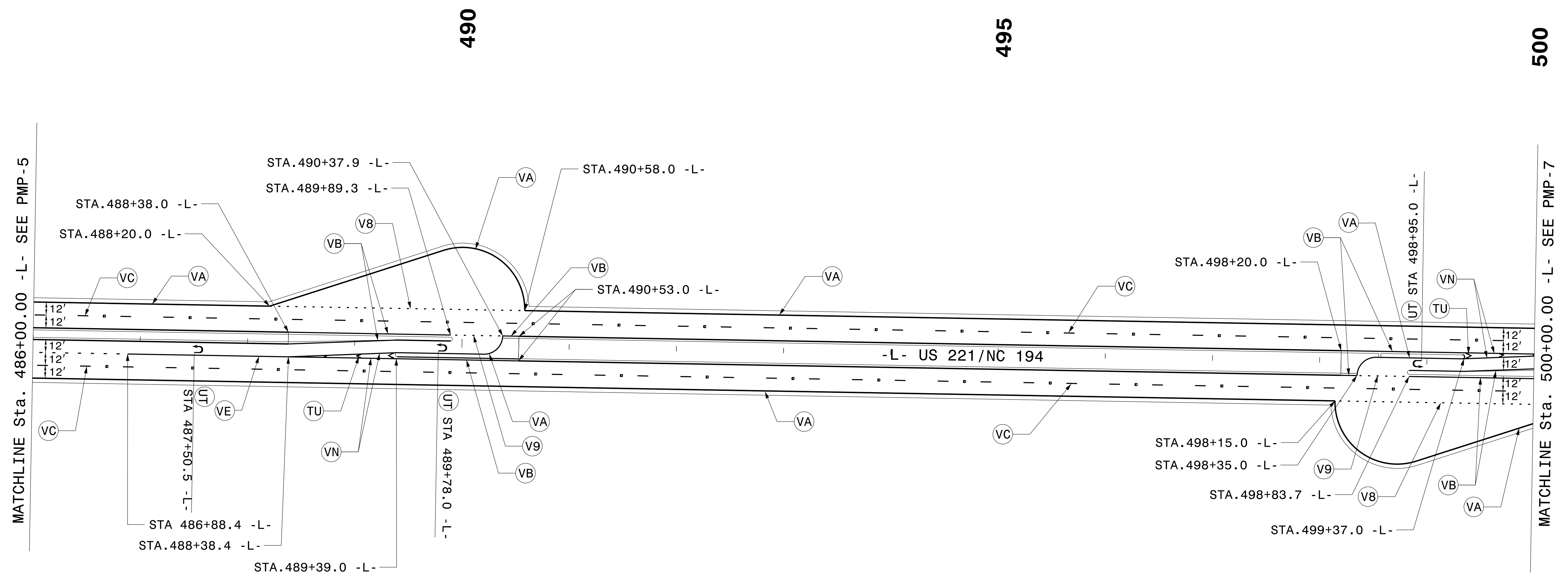
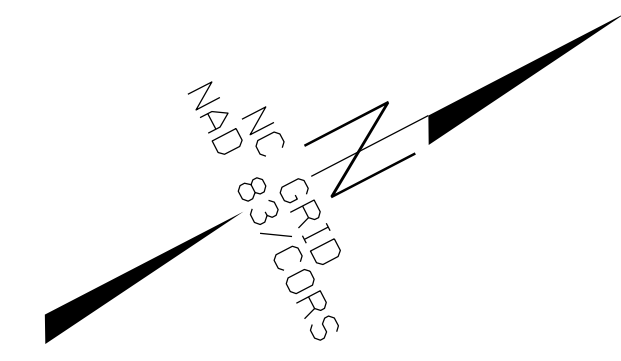

PAVEMENT MARKING DETAIL

\$\$\$\$\$\$SYTIME\$\$\$\$\$\$
 \$\$\$\$\$\$CONDN\$\$\$\$\$\$
 \$\$\$\$\$\$DUSER\$\$\$\$\$\$
 \$\$\$\$\$\$KAME\$\$\$\$\$\$
 \$\$\$\$\$\$\$\$\$\$\$\$