

MAP 1
 NC 49
 Tie in Mill at Map ends.
 Mill Bridge Approaches.
TIE DOWN ALL SIDE ROADS, except
MILL BUTT JOINT AT NC 8
TO TIE IN NEW SURFACE.
 Thermo entire Map excluding all
 concrete bridge decks, where Contractor
 will use Paint per NCDOT Standard
 Specification 1205.
 Concrete Bridge #3 and Bridge #8
 Paint quantities included in this Map.
 Note: See Typical Pave 2" in middle and
 1/2" at edge.

MAP 3—ROWAN COUNTY
 NC 49
 Tie in Mill at Map end.
 Mill Bridge Approaches.
 Note: See Typical Pave 2" in middle and
 1/2" at edge.

DAVIDSON COUNTY
 NORTH CAROLINA

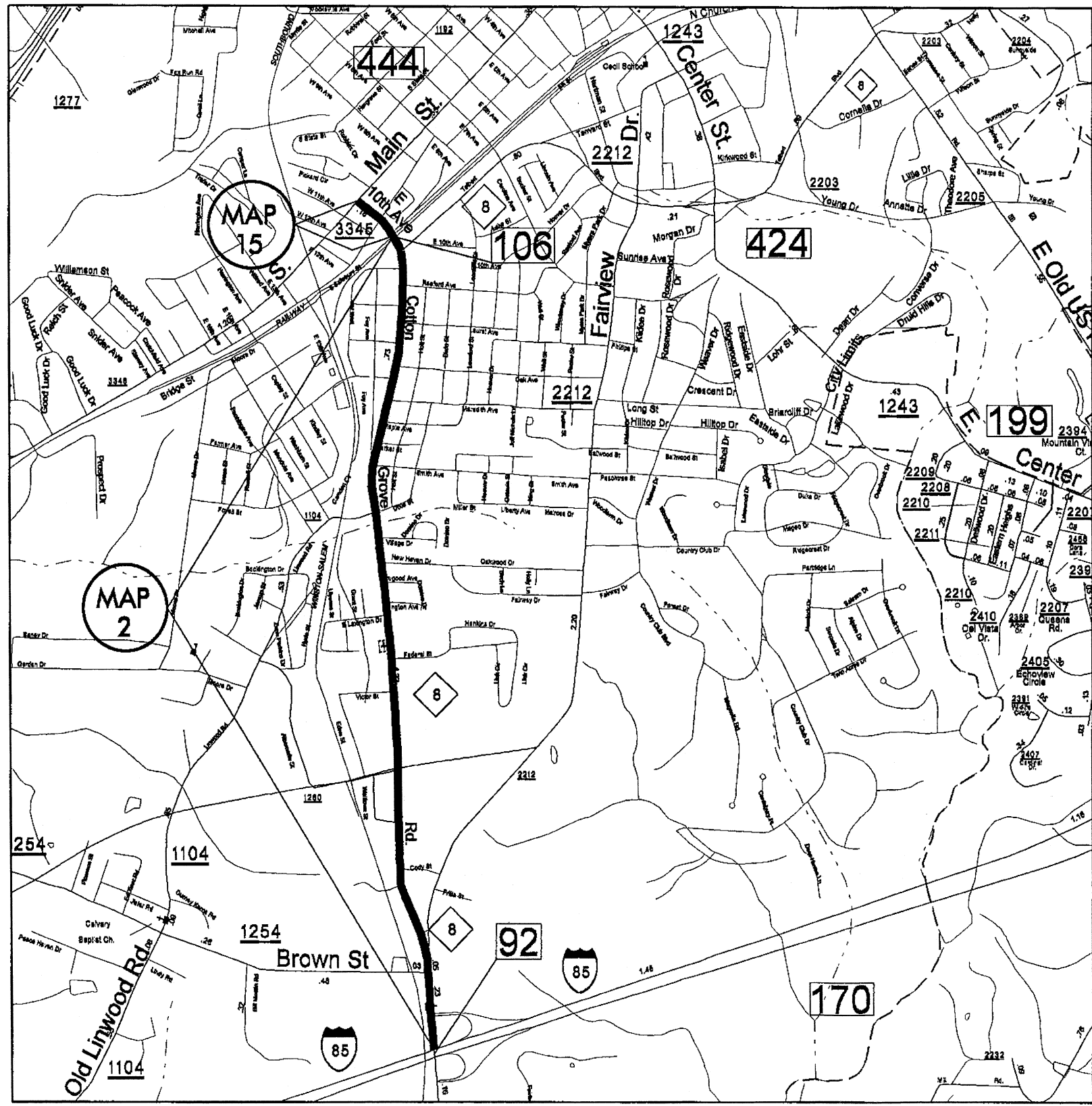

NOTES:

MAP 2
 NC 8/COTTON GROVE RD.
 MILL THE ASPHALT IN THE GUTTER TO
 EXPOSE THE GUTTER,
 THEN MILL 0-1½" AT A 12 FOOT WIDTH.
 Mill Tie in at Bridge Approach.

MAP 15
 SR 3345 E. 10TH AVENUE
 Tie in Mill.
 Mill Bridge Approaches.
 Mill Deck of Bridge #106 1".
 MILL Curb 0-1½" AT A 12 FOOT WIDTH.

DAVIDSON COUNTY
 NORTH CAROLINA

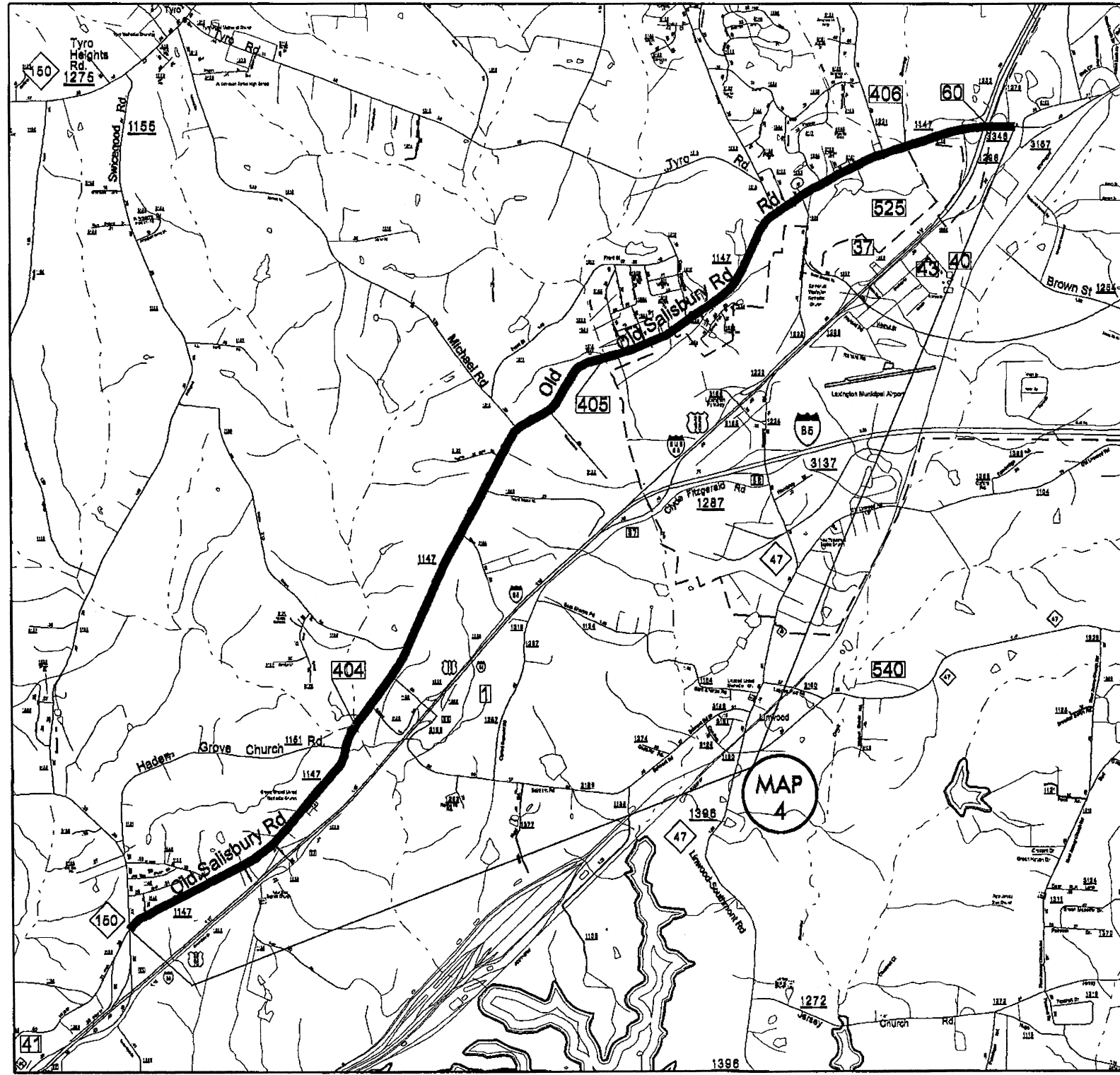

MAP 4
 SR 1147 OLD SALISBURY RD.
 Tie in Mill at Map ends.
 Mill Bridge Approaches.
 Thermo entire Map excluding all
 concrete bridge decks, where Contractor
 will use Paint per NCDOT Standard
 Specifaion 1205.

PROJECT REFERENCE NO.	SHEET NO.
9CR.10291.150, 9CR.20291.150 9CR.10801.151	4

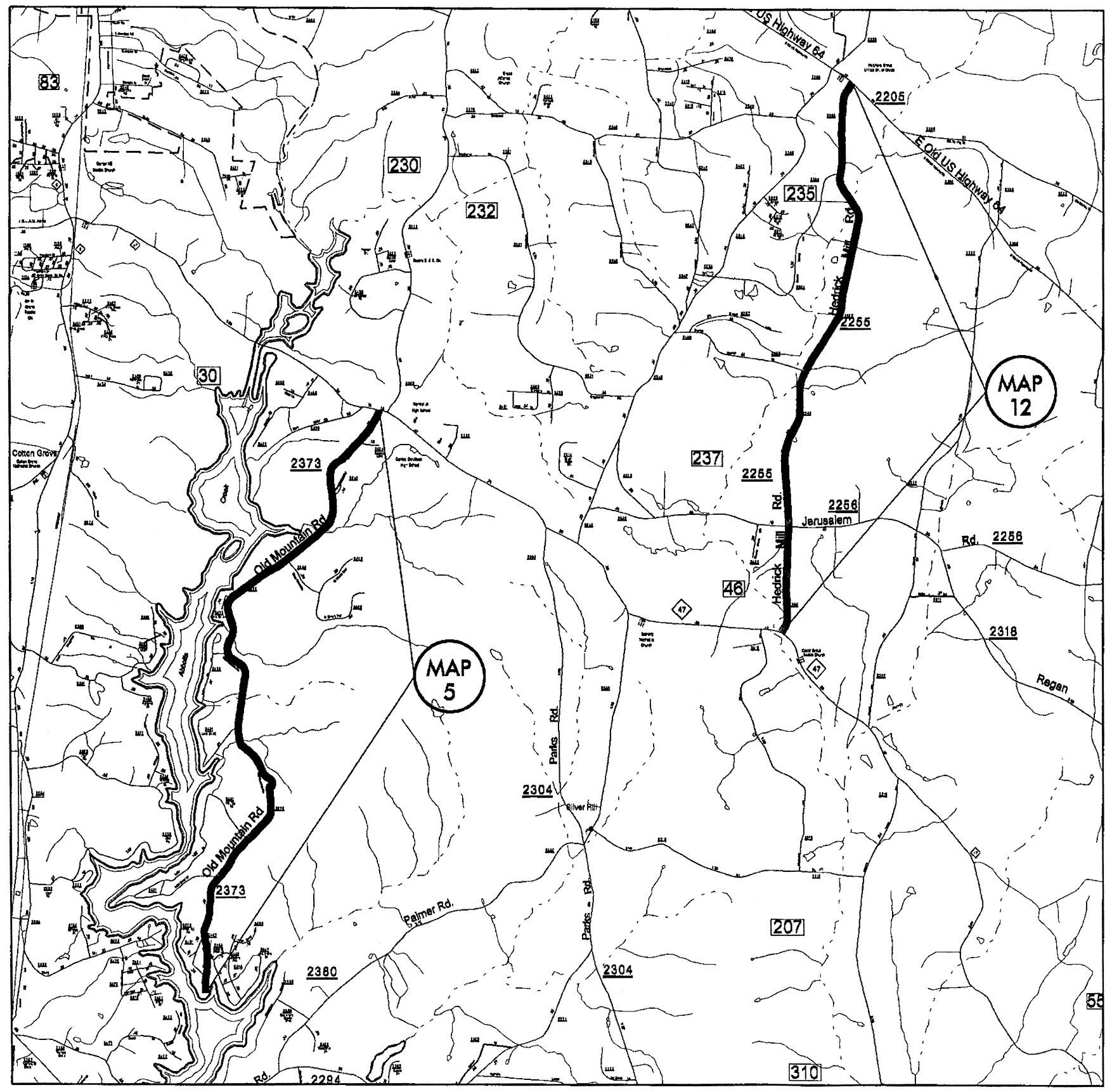

MAP 5
 SR 2373 Old Mountain Rd.
 NO Tie In Milling, Tie surface into
 existing surface.

MAP 12
 SR 2255 Hedrick Mill Rd.
 Tie in Mill at new pavement joints each
 side of new bridge.
 DO NOT Mill at approaches or on new
 Bridge Deck.

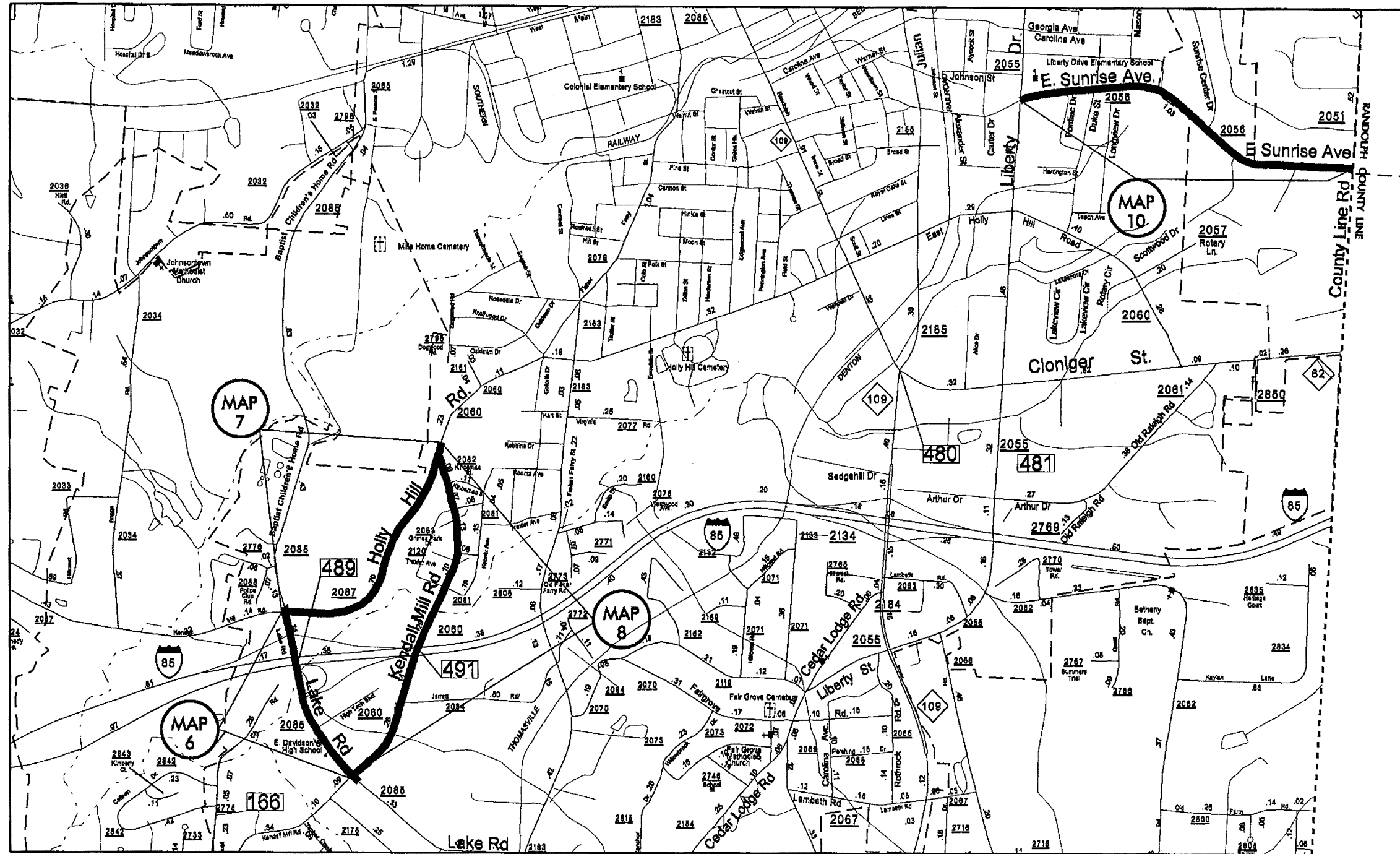

MAP 6
 SR 2085 LAKE RD.
 Tie in Mill at Map ends.
 Tie in Mill at all Ramps.
 Mill Bridge approaches.
 Thermo entire Map excluding concrete bridge deck, where Contractor will use Paint per NCDOT Standard Specification 1205.

MAP 7
 SR 2087 W. HOLLY HILL RD.
 Tie in Mill at Map ends.

MAP 8
 SR 2060 KENDALL MILL RD.
 Mill Bridge approaches.
 Tie into new surfaces at W. Holly Hill Rd. and Lake Rd.
 Thermo entire Map excluding concrete bridge deck, where Contractor will use Paint per NCDOT Standard Specification 1205.

MAP 10
 SR 2056 E. SUNRISE AVE.
 Tie in Mill at Map ends.
 Mill all curb 0-1½" including School drop off.
 Pave School drop off lane.

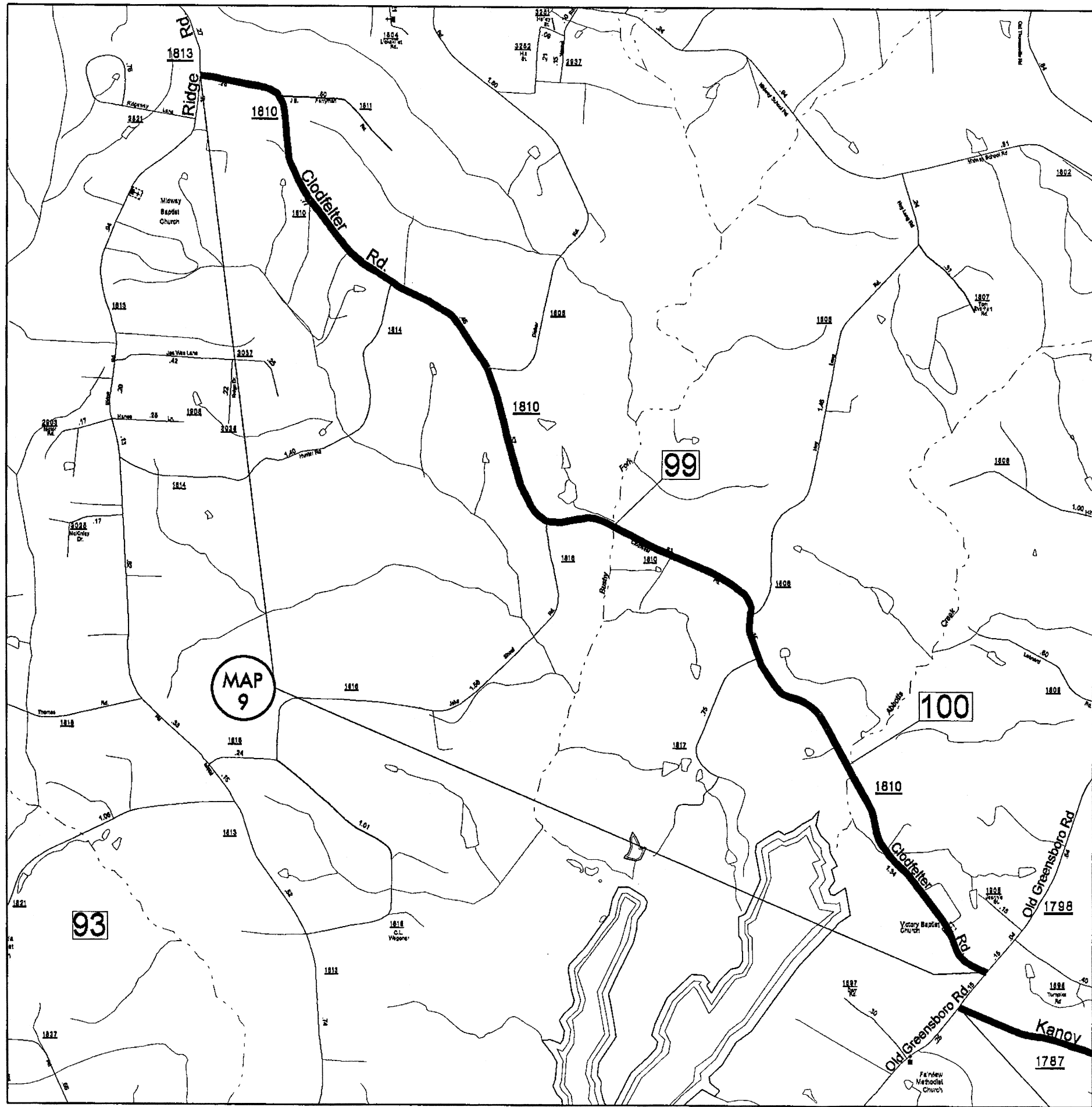

MAP 9
SR 1810 CLODFELTER RD.
 Tie in Mill at Map ends.
 Mill Bridge approaches.
 Thermo entire Map excluding concrete
 bridge decks, where Contractor
 will use Paint per NCDOT Standard
 Specificaion 1205.

DAVIDSON COUNTY
NORTH CAROLINA

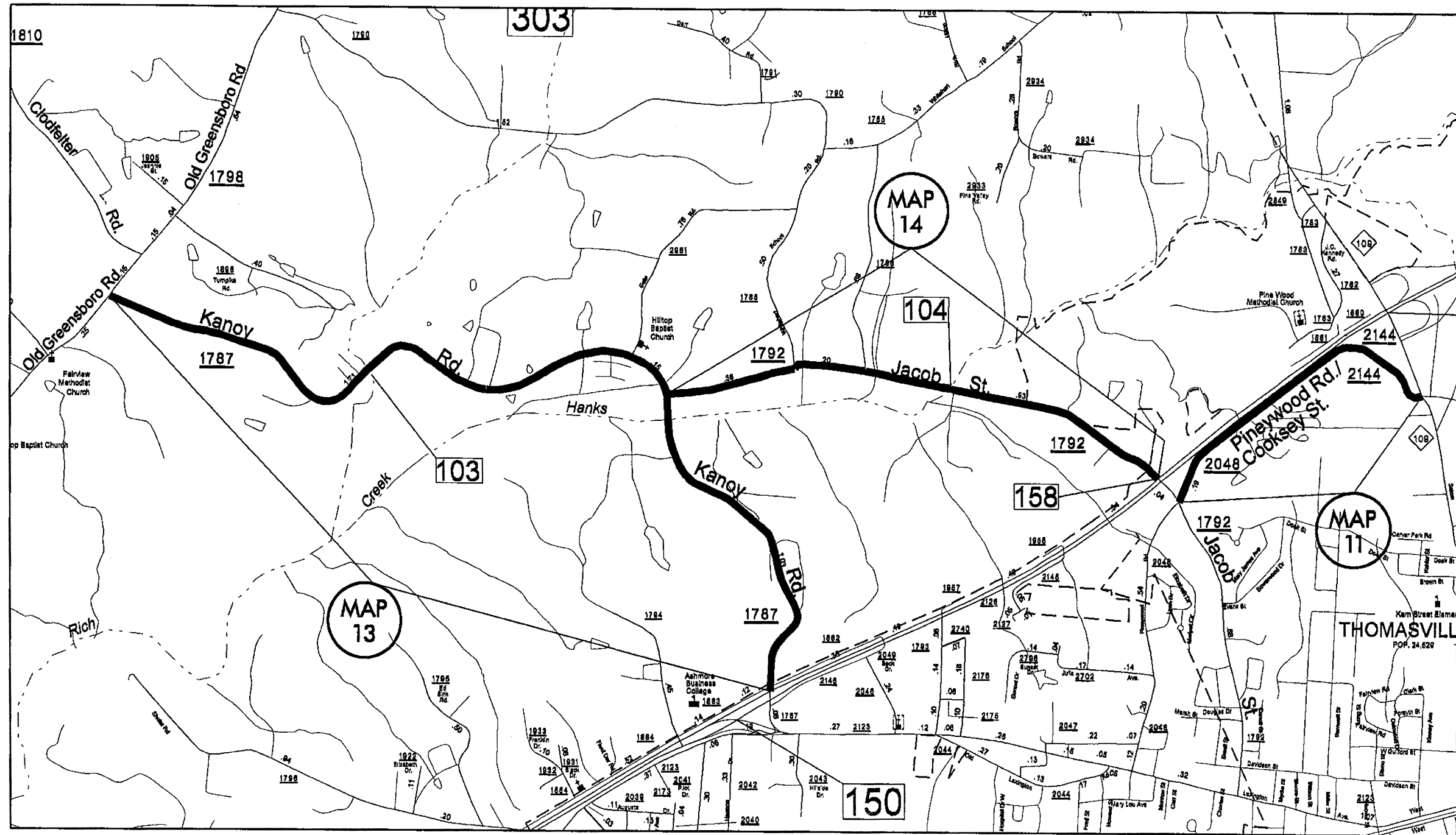

MAP 13
SR 1787 KANOY RD.
Tie in Mill at Map ends.
Mill Bridge #103 approaches and
Mill Bridge Deck 1½".

MAP 14
SR 1792 JACOB ST.
Tie into new surface at Kanoy Rd.
Mill Bridge #104 approaches and
Mill Bridge Deck 1½".
Mill to end Map at new Pavement Joint
near Bridge #158 over Bus. 85.

MAP 11
SR 2144 COOKSEY ST./
SR 2048 PINEYWOOD RD.
Tie in Mill Map ends.
Tie down at 3 way stop, Pave through.
Mill all curb 0-1½".

DAVIDSON COUNTY
NORTH CAROLINA

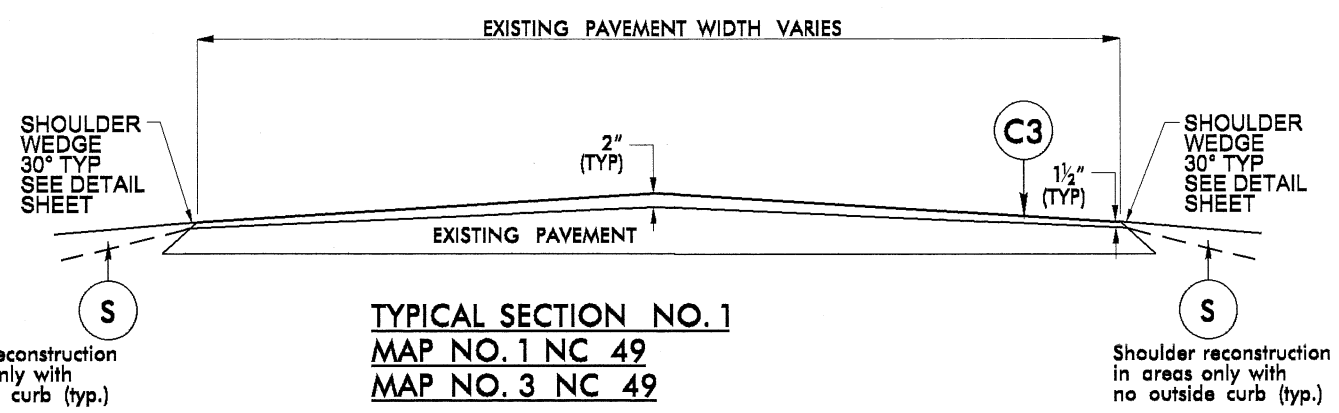

TYPICAL SECTION NO. 1
MAP NO. 1 NC 49
MAP NO. 3 NC 49

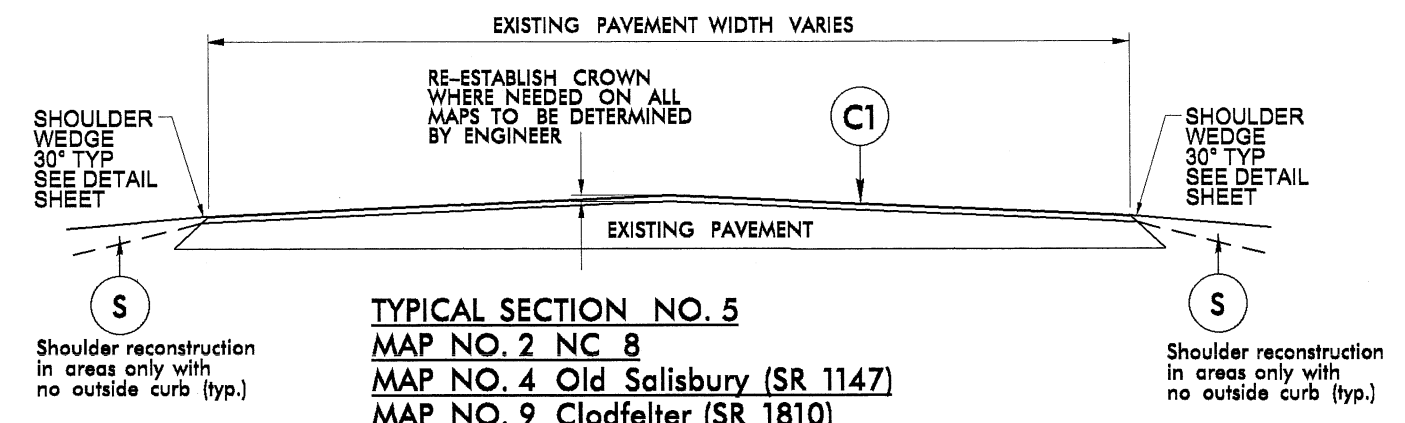

TYPICAL SECTION NO. 5
MAP NO. 2 NC 8
MAP NO. 4 Old Salisbury (SR 1147)
MAP NO. 9 Clodfelter (SR 1810)
MAP NO. 10 E. Sunrise (SR 2056)
MAP NO. 11 Cooksey Dr. (SR 2144)/Pinewood Rd. (SR 2048)
MAP NO. 12 Hedrick Mill (SR 2255)
MAP NO. 13 Kanoy Rd. (SR 1787)
MAP NO. 14 Jacob St. (SR 1792)

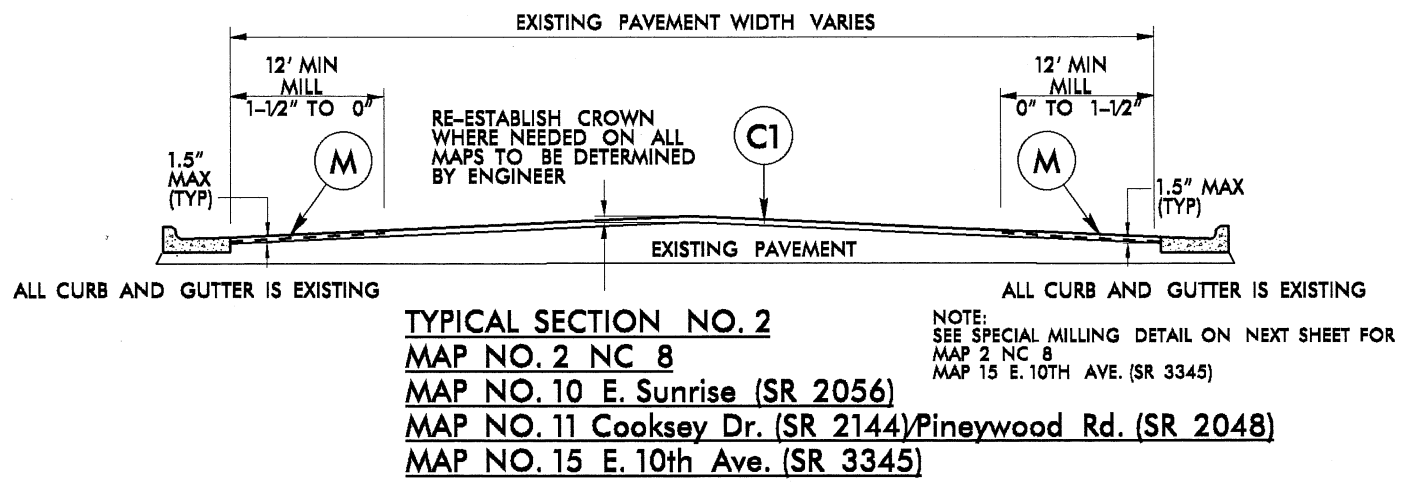

TYPICAL SECTION NO. 2
MAP NO. 2 NC 8
MAP NO. 10 E. Sunrise (SR 2056)
MAP NO. 11 Cooksey Dr. (SR 2144)/Pinewood Rd. (SR 2048)
MAP NO. 15 E. 10th Ave. (SR 3345)

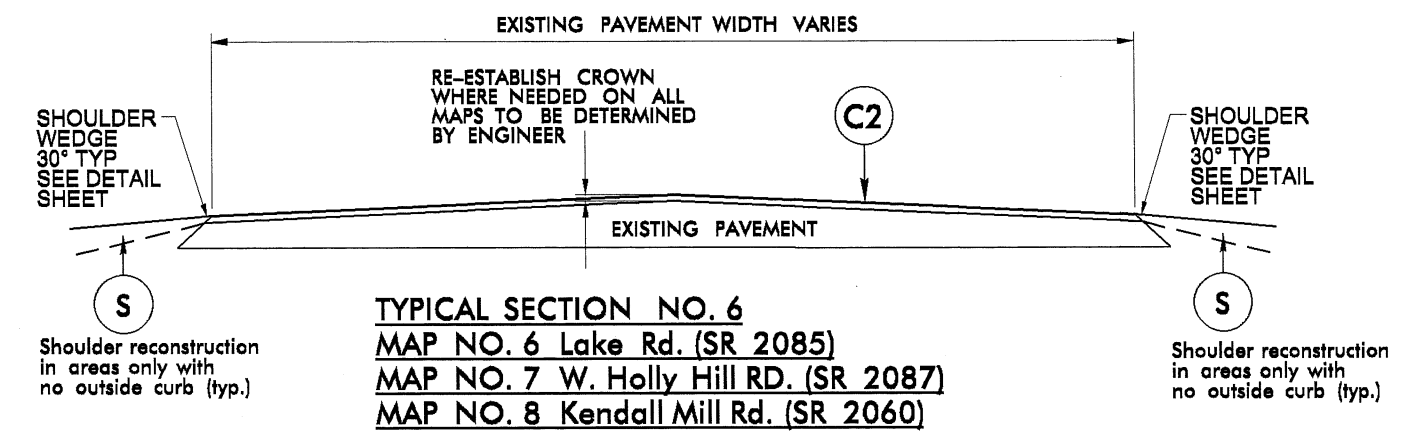

TYPICAL SECTION NO. 6
MAP NO. 6 Lake Rd. (SR 2085)
MAP NO. 7 W. Holly Hill RD. (SR 2087)
MAP NO. 8 Kendall Mill Rd. (SR 2060)

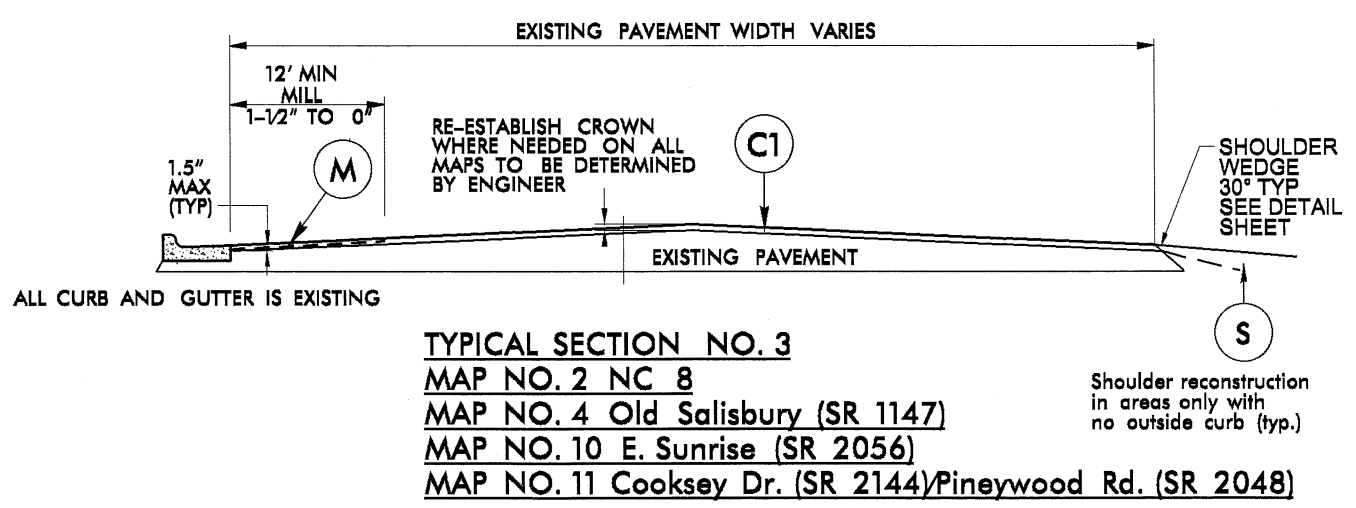

TYPICAL SECTION NO. 3
MAP NO. 2 NC 8
MAP NO. 4 Old Salisbury (SR 1147)
MAP NO. 10 E. Sunrise (SR 2056)
MAP NO. 11 Cooksey Dr. (SR 2144)/Pinewood Rd. (SR 2048)

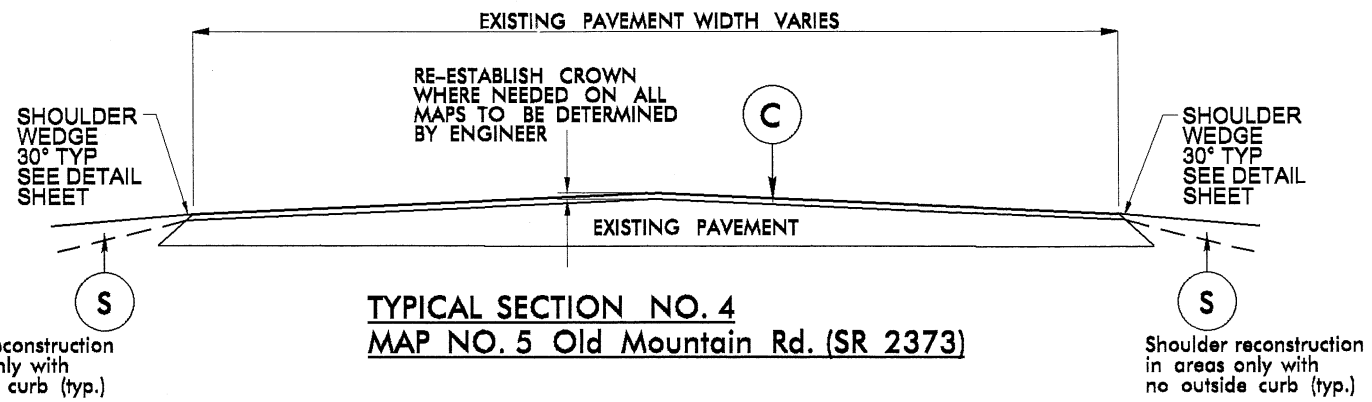

TYPICAL SECTION NO. 4
MAP NO. 5 Old Mountain Rd. (SR 2373)

PAVEMENT SCHEDULE	
C	PROP. APPROX. 1½" ASPHALT CONCRETE SURFACE COURSE, TYPE SF9.5A, TO BE APPLIED AT AN AVERAGE RATE OF 165 LBS PER SQ YD.
C1	PROP. APPROX. 1½" ASPHALT CONCRETE SURFACE COURSE, TYPE S9.5B, TO BE APPLIED AT AN AVERAGE RATE OF 168 LBS PER SQ YD.
C2	PROP. APPROX. 2" ASPHALT CONCRETE SURFACE COURSE, TYPE S9.5B, TO BE APPLIED AT AN AVERAGE RATE OF 224 LBS PER SQ YD.
C3	PROP. VARIABLE DEPTH ASPHALT CONCRETE SURFACE COURSE, TYPE S9.5C, AT AN AVERAGE RATE OF 112 LBS PER SQ YD. PER 1" DEPTH TO BE PLACED IN LAYERS NOT TO EXCEED 2" IN DEPTH.
M	MILL ASPHALT PAVEMENT, 0" TO 1½"
M1	MILL ASPHALT PAVEMENT, 0" TO 2"
S	SHOULDER RECONSTRUCTION (SEE DETAIL)
U	EXISTING PAVEMENT

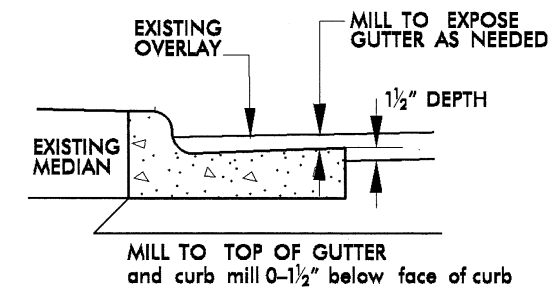
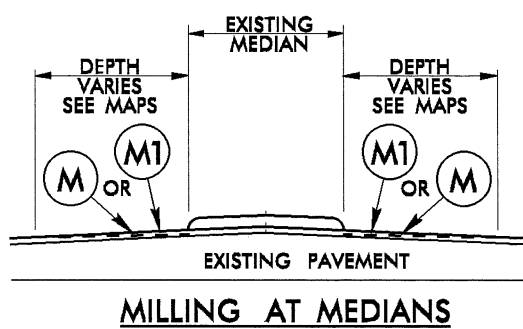
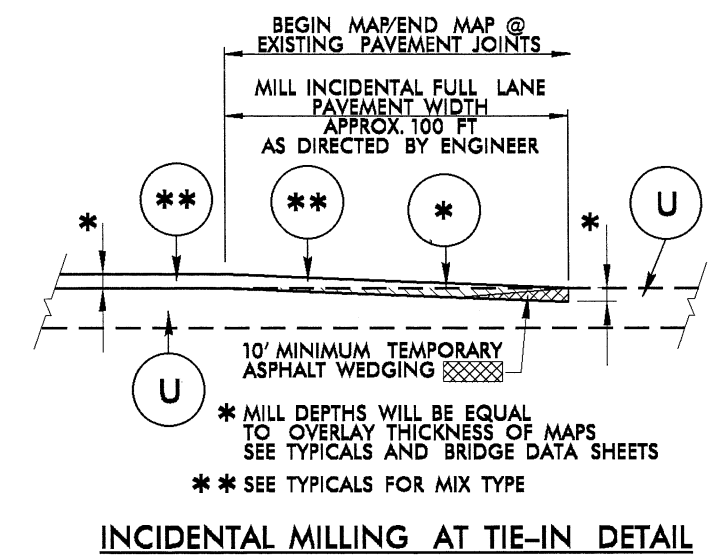
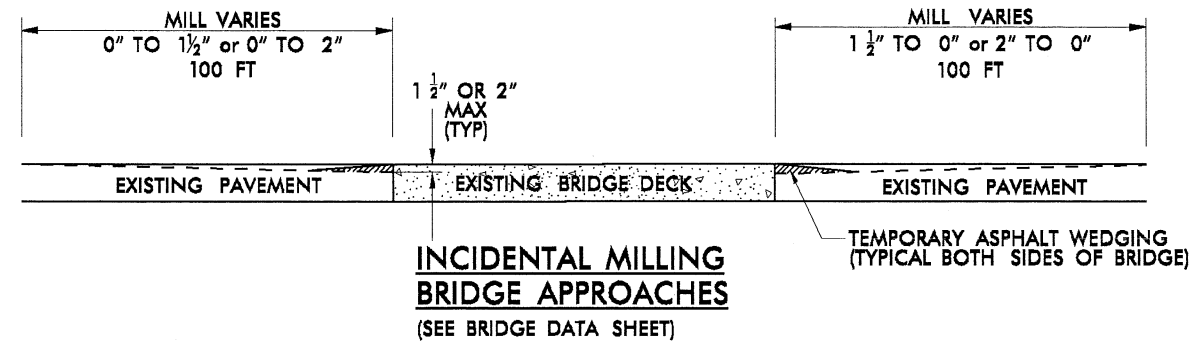

MAP 2 NC 8
MAP 15 E. 10TH AVE. (SR 3345)

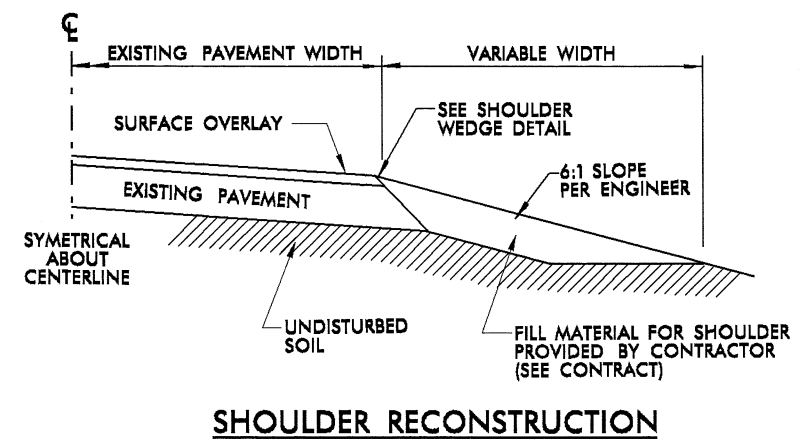

PAVEMENT SCHEDULE	
C	PROP. APPROX. 1 1/2" ASPHALT CONCRETE SURFACE COURSE, TYPE SF9.5A, TO BE APPLIED AT AN AVERAGE RATE OF 165 LBS PER SQ YD.
C1	PROP. APPROX. 1 1/2" ASPHALT CONCRETE SURFACE COURSE, TYPE S9.5B, TO BE APPLIED AT AN AVERAGE RATE OF 168 LBS PER SQ YD.
C2	PROP. APPROX. 2" ASPHALT CONCRETE SURFACE COURSE, TYPE S9.5B, TO BE APPLIED AT AN AVERAGE RATE OF 224 LBS PER SQ YD.
C3	PROP. VARIABLE DEPTH ASPHALT CONCRETE SURFACE COURSE, TYPE S9.5C, AT AN AVERAGE RATE OF 112 LBS PER SQ YD. PER 1" DEPTH TO BE PLACED IN LAYERS NOT TO EXCEED 2" IN DEPTH.
M	MILL ASPHALT PAVEMENT, 0" TO 1 1/2"
M1	MILL ASPHALT PAVEMENT, 0" TO 2"
S	SHOULDER RECONSTRUCTION (SEE DETAIL)
U	EXISTING PAVEMENT

CONSTRUCTION NOTES:

1. ALL QUANTITIES ARE "ESTIMATED" AS INDICATED IN THE "SUMMARY OF QUANTITIES".
2. CONSTRUCTION SHALL PROGRESS IN PHASES, IN THE ORDER INDICATED BELOW:
 - PHASE 1 - MILLING AND PATCHING (WHEN REQUIRED)
 - PHASE 2 - SURFACE OVERLAY
 - PHASE 3 - SHOULDER DROP-OFF REPAIR (AS NEEDED AND DIRECTED BY ENGINEER)
 - PHASE 4 - UTILITY ADJUSTMENTS (MANHOLE RING/COVER, VALVE/METER BOX RING/COVER, CATCH BASIN GRATE/COVER, DROP INLET GRATE/COVER, ETC.) WHEN REQUIRED.
3. BRIDGES THAT HAVE FLOOR DRAINS, SHALL HAVE ALL FLOOR DRAINS LEFT OPEN. EXTRA CARE SHALL BE EXERCISED IN MILLING (IF REQUIRED) AND IN PLACING THE WEARING SURFACE AROUND FLOOR DRAINS SO AS NOT TO HINDER EFFECTIVE DRAINAGE.
4. TEMPORARY ASPHALT WEDGING SHALL BE PLACED ON THE SAME DAY THAT BRIDGE AND/OR RAILROAD APPROACHES ARE MILLED (AND IF APPROACHES ARE MILLED PRIOR TO BRIDGE DECK).
5. FOR TWO-LANE ROADWAYS - IT SHALL BE UNDERSTOOD THAT TYPICALLY ON A ROADWAY MEASURING 20 FEET OR LESS IN WIDTH, THE CENTER OF THE WHITE EDGELINE SHALL BE LOCATED SIX INCHES FROM THE EDGE OF PAVEMENT ON EITHER SIDE OF THE ROADWAY; ON A ROADWAY MEASURING 22 FEET IN WIDTH, TRAVEL LANES SHALL MEASURE 10 FEET AND THE WHITE EDGELINE SHALL BE LOCATED ONE FOOT FROM THE EDGE OF PAVEMENT ON EITHER SIDE; ON A ROADWAY MEASURING 24 FEET IN WIDTH, TRAVEL LANES SHALL MEASURE 11 FEET AND THE WHITE EDGELINE SHALL BE LOCATED ONE FOOT FROM THE EDGE OF PAVEMENT ON EITHER SIDE; ON A ROADWAY MEASURING 26 FEET OR MORE IN WIDTH, TRAVEL LANES SHALL MEASURE 12 FEET AND THE WHITE EDGELINE SHALL BE LOCATED NO LESS THAN ONE FOOT FROM THE EDGE OF PAVEMENT ON EITHER SIDE. THIS SHALL BE STANDARD PRACTICE UNLESS OTHERWISE DIRECTED BY THE ENGINEER.
6. PAPER JOINTS ARE TO BE PLACED BETWEEN DAYS OF PAVING OPERATIONS AS SPECIFIED IN THE STANDARD SPECIFICATIONS SECTION 610-11.
7. ALL MILLED AREAS WILL BE PAVED WITHIN 72 HOURS UNLESS APPROVED BY THE ENGINEER.
9. REPLACE ANY PORTION OF STOP BARS AND OTHER PAVEMENT MARKINGS AT ANY INTERSECTION INCLUDING Y-LINES NOT ACTUALLY BEING PAVED OVER, THAT ARE OBLITERATED BY THE PAVING OPERATION EITHER BY HAULING WHEEL TRACKS OR TACK TRUCK BY THE END OF EACH RESURFACING OPERATION

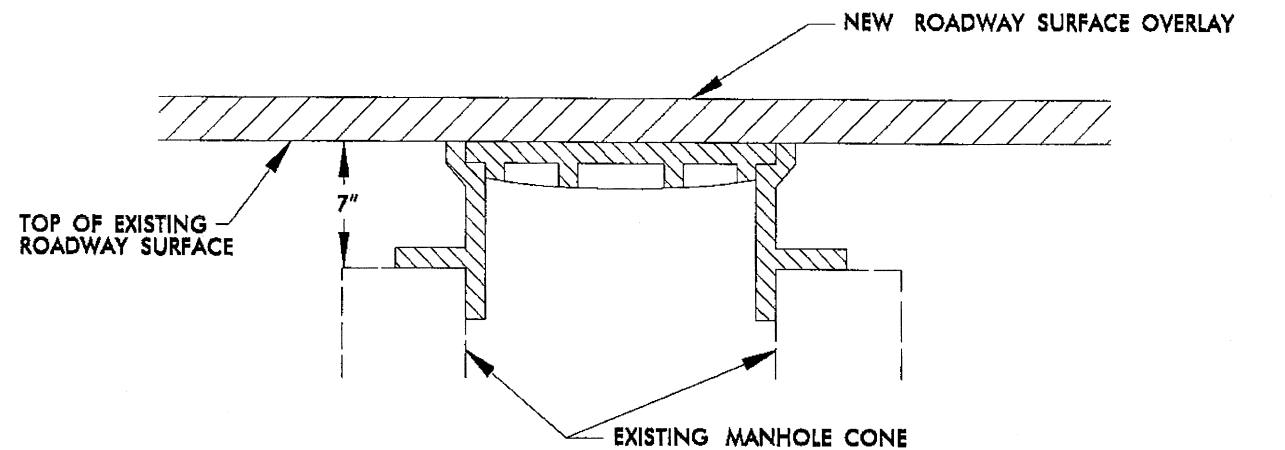

STEP 1

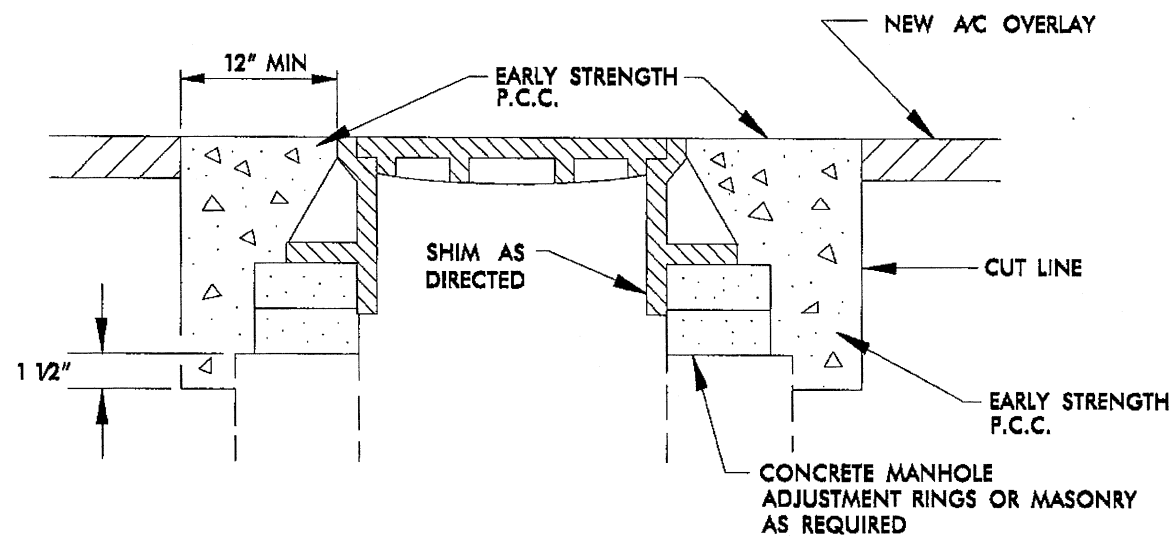

STEPS 2,3, & 4

- STEP 1 COVER EXISTING MANHOLE WITH APPROVED MATERIAL AND CONSTRUCT OVERLAY ACROSS TOP OF MANHOLE
- STEP 2 SAW CUT EXCAVATION AROUND MANHOLE 12" MIN. FROM MANHOLE FRAME.
- STEP 3 RAISE MANHOLE FRAME RINGS TO FINISH PAVEMENT PROFILE AND CROSS SLOPE.
- STEP 4 BACKFILL WITH EARLY STRENGTH P.C.C. TO DEPTHS AS DIRECTED.

MANHOLE ADJUSTMENT DETAIL

Davidson County/Rowan County 2015 Resurfacing Bridge Listing

								PROJECT NO.	SHEET NO.	TOTAL NO.	
								9CR.10291.150, 9CR.10801.151, 9CR.20291.150	11		
Map No.	Route No.	Route Name	Bridge No.	Feature Intersected	Floor Construction	Clear Roadway Width (Ft)	Horizontal Clearance Under (Ft.)	Vertical Clearance Under	Length (Ft)	Posting	Recommended Treatment, From Bridge Maintenance
1,3	NC 49	NC 49 NBL	3	YADKIN RIVER & WSSB RR	7.5 RC, SLAB	28	NA	NA	1094	NA	MILL APPROACH; Do not pave on bridge
1,3	NC 49	NC 49 SBL	8	YADKIN RIVER & WSSB RR	4.75 RC, 3.5 PPC	31.5	NA	NA	1107	NA	MILL APPROACH; Do not pave on bridge
1	NC 49	NC 49	8	NC 109	6 3/4 RC, 4.0 AWS	28	NA	NA	133	NA	MILL APPROACHES; MILL DECK 1 1/2"
2	NC 8	NC 8/COTTON GROVE RD.	92	I85	8 3/4 RC, SLAB	75.7	NA	NA	273	NA	MILL APPROACHES; Do not pave on bridge
4	SR 1147	US29 & 70/OLD SALISBURY RD. RD.	60	US29/US70/ I85BUS. LOOP	8 1/2 RC, SLAB	70	NA	NA	257	NA	MILL APPROACHES; Do not pave on bridge
4	SR 1147	OLD SALISBURY RD. RD.	404	SOUTH POTTS CREEK	8.5 RC, 3.5 PPC	29.8	NA	NA	231	NA	MILL APPROACHES; Do not pave on bridge
4	SR 1147	OLD SALISBURY RD. RD.	405	POTTS CREEK	PPCCS, 5.38"AWS	30.8	NA	NA	180	NA	MILL APPROACHES; MILL DECK 1 1/2"
4	SR 1147	OLD SALISBURY RD. RD.	406	SWEARING CREEK	PPCCS, 5AWS	36	NA	NA	168	NA	MILL APPROACHES; MILL DECK 1 1/2"
6	SR 2085	LAKE RD.	489	I85	7 7/8 RC, SLAB	72	NA	NA	268	NA	MILL APPROACHES; Do not pave on bridge
8	SR 2060	KENDALL MILL RD.	491	I85	7.75 RC, SLAB	40	NA	NA	312	NA	MILL APPROACHES; Do not pave on bridge
9	SR 1810	CLODFELTER RD.	99	BUSHY FORK CREEK	5 3/4 RC, SLAB	22	NA	NA	113	SV 18 TTST 22	MILL APPROACHES; Do not pave on bridge
9	SR 1810	CLODFELTER RD.	100	ABBOTTS CREEK	5 3/4 RC, SLAB	22	NA	NA	175	SV 17 TTST 23	MILL APPROACHES; Do not pave on bridge
12	SR 2255	HEDRICK MILL RD.	235	FOUR MILE CREEK	PPCCS,AWS	27.8	NA	NA	57.2	NA	DO NOT MILL APPROACHES; DO NOT MILL DECK TIE IN AT NEW PAVEMENT JOINTS
13	SR 1787	KANOY RD.	103	RICH FORK CREEK	PPCCS, 4.25 AWS	30	NA	NA	133	SV 17 TTST 23	MILL APPROACHES; MILL DECK 1 1/2"
14	SR 1792	JACOB ST.	104	HANKS CREEK	PPCCS, 3.25 AWS	30.3	NA	NA	92	SV 17 TTST 23	MILL APPROACHES; MILL DECK 1 1/2"
15	SR 3345	E. 10TH AVENUE	106	SOUTHERN RAILWAY	6.75 RC, 1 AWS	36	NA	NA	158	NA	MILL APPROACHES; MILL DECK 1"

- NOTES:
 1) DETAIL DOES NOT APPLY TO OGAFc AND ULTRA-THIN BONDED WEARING COURSE.
 2) BACKFILL SHOULDER WITH APPROVED MATERIAL.
 3) THE SHOULDER WEDGE DEVICE MAY BE DISENGAGED AT PAVED DRIVEWAYS AND SIDE STREETS.

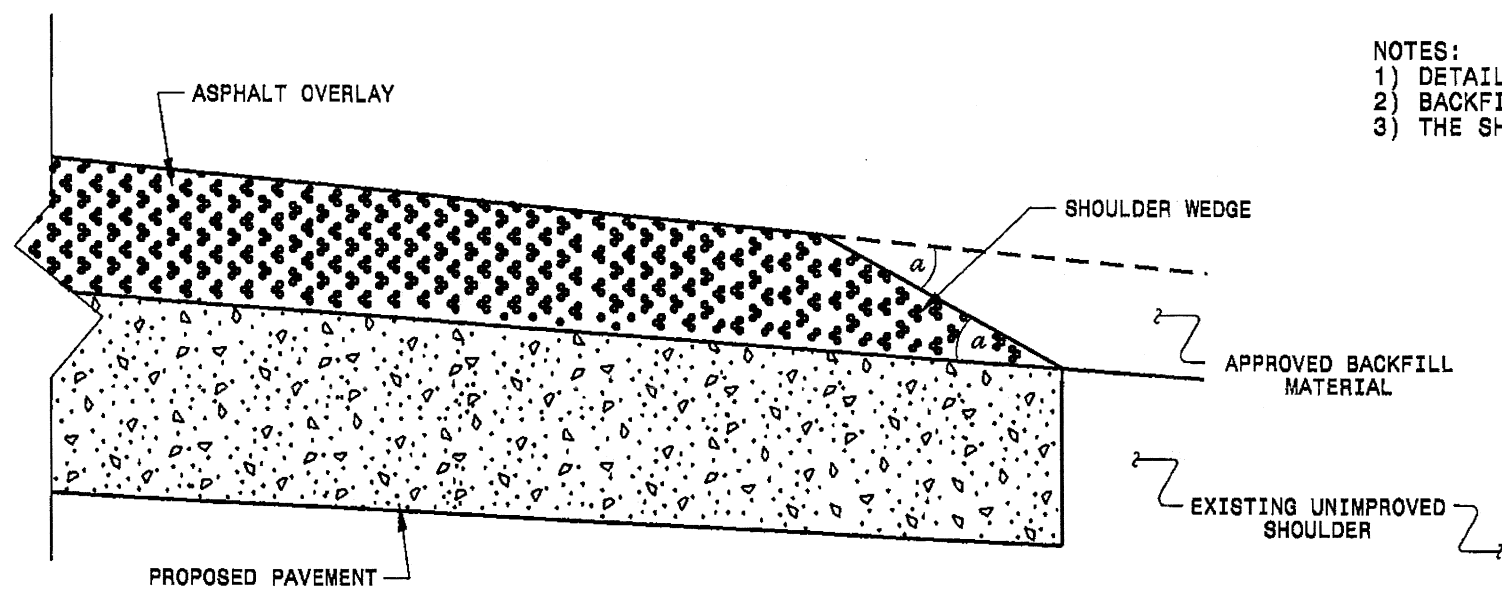

SHOULDER WEDGE DETAIL
 (Resurfacing Projects w/ Widening or
 with Existing Paved Shoulder having no dropoffs)

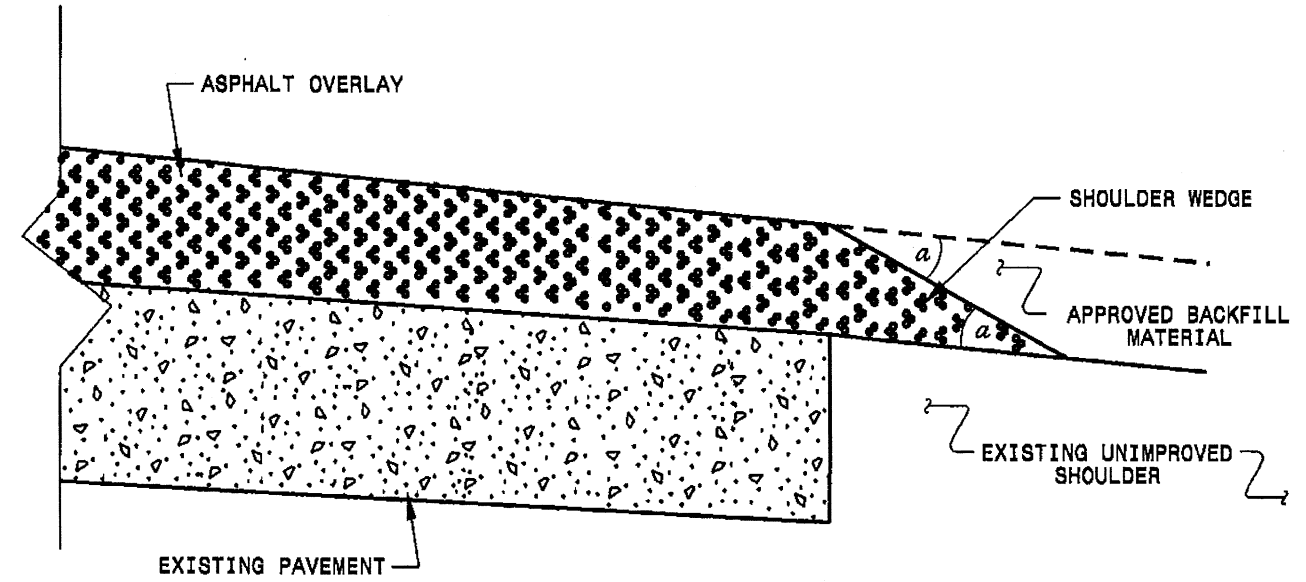

SHOULDER WEDGE DETAIL
 (Resurfacing Projects w/ NO Widening)

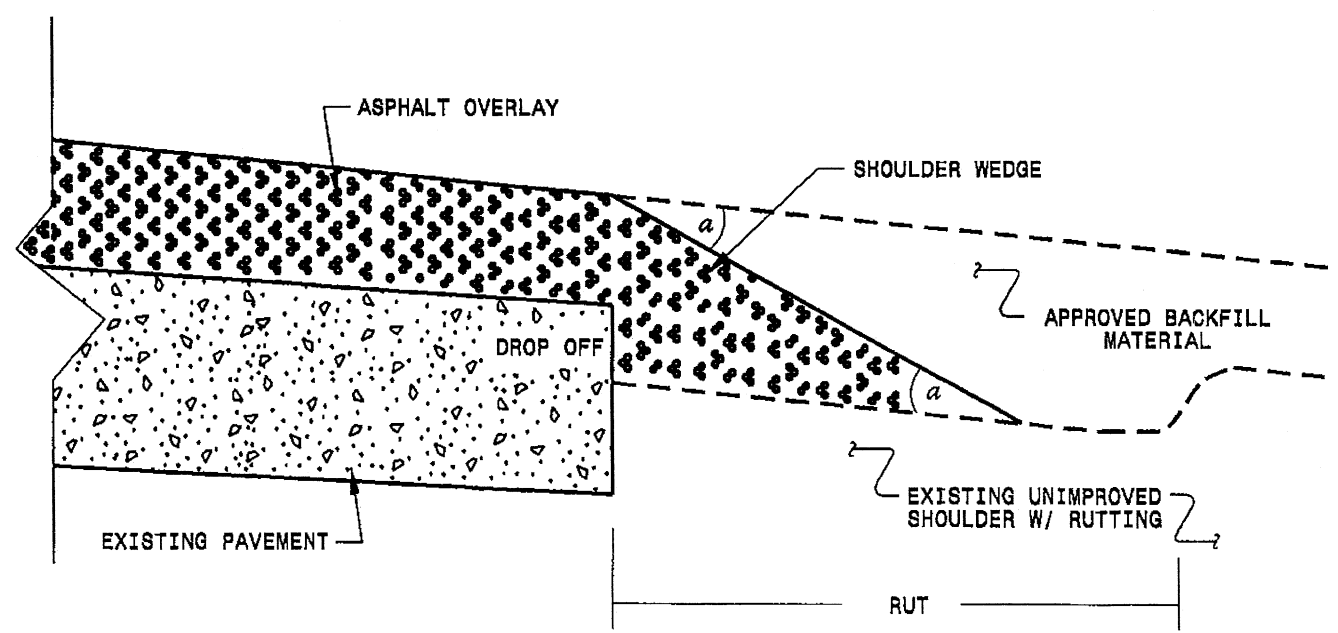

SHOULDER WEDGE DETAIL
 (Resurfacing Adjacent to
 Rutted Shoulder)

- SHOULDER WEDGE ANGLE = 30°

CONTRACT STANDARDS AND DEVELOPMENT UNIT Office 818-707-8930 FAX 918-250-4119			
SHOULDER WEDGE DETAILS			
ORIGINAL BY:	T.SPELL	DATE:	7-18-11
MODIFIED BY:		DATE:	10/18/12
CHECKED BY:		DATE:	
FILE SPEC.:	S:\MHC\8848338\8848338\8848338\8848338.dgn		

07-APR-2014 14:00
 C:\NDP\116\2613
 B:\cadd\11 A1 D:\CAD\268339
 \Davidson\2015_Resurfacing-Davidson_REVISED Shoulder Wedge Detail.dgn

PROJECT NO.	SHEET NO.	TOTAL NO.
9CR.10291.150, ETC	13	

SUMMARY OF QUANTITIES

PROJECT NO	COUNTY	MAP NO	ROUTE	DESCRIPTION	TYP	LANES	LANE TYPE	FINAL SURFACE TESTING REQUIRED	WARM MIX ASPHALT REQUIRED	LENGTH MI	WIDTH FT	BORROW EXCAVATION CY	INCIDENTAL STONE BASE TONS	SHOULDER RECONSTRUCTION SMI	MILLING ASPHALT PAVEMENT, 1 1/2" DEPTH SY	MILLING ASPHALT PAVEMENT, 1" DEPTH SY	MILLING ASPHALT PAVEMENT, 0" TO 1 1/2" DEPTH SY	MILLING ASPHALT PAVEMENT, 0" TO 2" DEPTH SY	INCIDENTAL MILLING SY	SURFACE COURSE, S9.5B TONS	SURFACE COURSE, S9.5C TONS	SURFACE COURSE, SF9.5A TONS	ASPHALT BINDER FOR PLANT MIX TONS	PATCHING EXISTING PAVEMENT TONS	ADJ. OF DROP INLET EA	ADJ. OF MAN-HOLE EA	ADJ. OF METER OR VALVE BOX EA	TEMPORARY SILT FENCE LF	WATTLE LF
9CR.10291.150	Davidson	1	NC 49	FROM PAVEMENT JT. NEAR RANDOLPH CO. LINE TO BRIDGE NO. 3 AND NO. 8 OVER YADKIN RIVER	1	2	2WU	NO	NO	8.715	28-56	1,046	852	17.43	414				2,261		16,319		963	20				3,486	349
9CR.10291.150	Davidson	2	NC 8/COTTON GROVE ROAD	FROM I-85 BRIDGE # 92 TO BRIDGE # 106 NEAR TALBERT BLVD.	2,3,5	2	2WU	NO	NO	2.242	24-48	139	99	2.32			8,501	10,757	533	5,579			335	20	8	18	13	464	46
TOTAL FOR PROJ NO. 9CR.10291.150										10.957		1,185	951	19.75	414		8,501	10,757	2,794	5,579	16,319		1,298	40	8	18	13	3,950	395
9CR.10801.151	Rowan	3	NC 8/ NC 49	FROM BRIDGE NO. 3 AND NO. 8 OVER YADKIN RIVER TO STANLY CO. LINE	1	4	MD	NO	NO	0.192	28-56	23		0.38					1,244		736		43	20				77	8
TOTAL FOR PROJ NO. 9CR.10801.151										0.192		23		0.38					1,244		736		43	20				77	8
9CR.20291.150	Davidson	4	SR 1147 OLD SALISBURY RD.	FROM PAVEMENT JT. AT NC 150 TO PAVEMENT JT. AT GRIMES BLVD.	3,5	2	2WU	NO	NO	7.093	22	851	640	14.19	1,288				3,554	9,539			572	20			14	2,837	284
9CR.20291.150	Davidson	5	SR 2373 OLD MOUNTAIN RD.	FROM NC 47 TO DEAD END INCLUDING CIRCLE	4	2	2WU	NO	NO	4.154	20	498	165	8.31							4,521		303	20			6	1,662	166
9CR.20291.150	Davidson	6	SR 2085 LAKE RD.	FROM SR 2087 W. HOLLY HILL RD. TO SR 2060 KENDALL MILL RD.	6	2	2WU	NO	NO	0.561	35	67	60	1.12					4,696	1,842			111	20				224	22
9CR.20291.150	Davidson	7	SR 2087 W. HOLLY HILL RD.	SR 2085 LAKE RD. TO SR 2060 KENDALL MILL RD.	6	2	2WU	NO	NO	0.734	22	88	126	1.47					444	1,281			77	20				294	29
9CR.20291.150	Davidson	8	SR 2060 KENDALL MILL RD.	FROM SR 2085 LAKE RD. TO SR 2087 W. HOLLY HILL RD.	6	2	2WU	NO	NO	0.98	21	118	120	1.96					511	1,515			91	20		1	4	392	39
9CR.20291.150	Davidson	9	SR 1810 CLODFELTER	FROM SR 1798 OLD GREENSBORO RD. TO SR 1813 RIDGE RD.	5	2	2WU	NO	NO	4.381	20	526	294	8.76					1,422	4,779			287	20			1	1,752	175
9CR.20291.150	Davidson	10	SR 2056 EAST SUNRISE AVE.	FROM LIBERTY DRIVE TO COUNTY LINE ROAD (RANDOLPH COUNTY)	2,3,5	2	2WU	NO	NO	1.015	24	122	18	2.03			4,370		645	1,664			100	20		2	2	406	41
9CR.20291.150	Davidson	11	SR 2144 COOKSEY ST./ SR 2048 PINEYWOOD RD.	FROM SR 1792 JACOBS ST./DR. MLK, JR. DR. TO NC 109	2,3,5	2	2WU	NO	NO	0.945	22	72	15	1.20			4,671		488	1,133			68	20		2	1	240	24
9CR.20291.150	Davidson	12	SR 2255 HEDRICK MILL RD.	FROM SR 2205 OLD US 64 TO NC 47	5	2	2WU	NO	NO	3.471	20	417	240	6.94					1,063	3,787			227	20				1,388	139
9CR.20291.150	Davidson	13	SR 1787 KANOY RD.	FROM SR 1798 OLD GREENSBORO RD. TO PAVEMENT JT. NEAR BUS 85	5	2	2WU	NO	NO	2.892	22	347	273	5.78	443				1,288	3,469			208	20				1,157	116
9CR.20291.150	Davidson	14	SR 1792 JACOB ST.	FROM SR 1787 KANOY RD. TO PAVEMENT JT AT BRIDGE #158 OVER BUS 85	5	2	2WU	NO	NO	1.426	22	171	192	2.85	310				244	1,860			112	20			2	570	57
9CR.20291.150	Davidson	15	SR 3345 E. 10TH AVENUE	FROM PAVEMENT JT ON SOUTH SIDE OF BRIDGE # 106 NEAR TALBERT BLVD. TO S. MAIN ST. (SR 3346)	2	2	2WU	NO	NO	0.148	36						632	2,083	400	219			13	20		2	2		
TOTAL FOR PROJ NO. 9CR.20291.150										27.8		3,277	2,143	54.61	2,041	632	15,844		14,755	31,088		4,521	2,169	240		7	32	10,922	1,092
GRAND TOTAL										38.949		4,485	3,094	74.74	2,455	632	24,345	10,757	18,793	36,667	17,055	4,521	3,510	300	8	25	45	14,949	1,495

NOTES: Less than 5' - 10' undisturbed buffer from ROW, ditchline, water feature, or drainage inlet, add BMP.

BMP Options: Wattle or Silt Fence

EROSION CONTROL DETAIL

PROJECT REFERENCE NO.	SHEET NO.
9CR.10291.150,9CR.20291.150,9CR.10801.151	EC-1

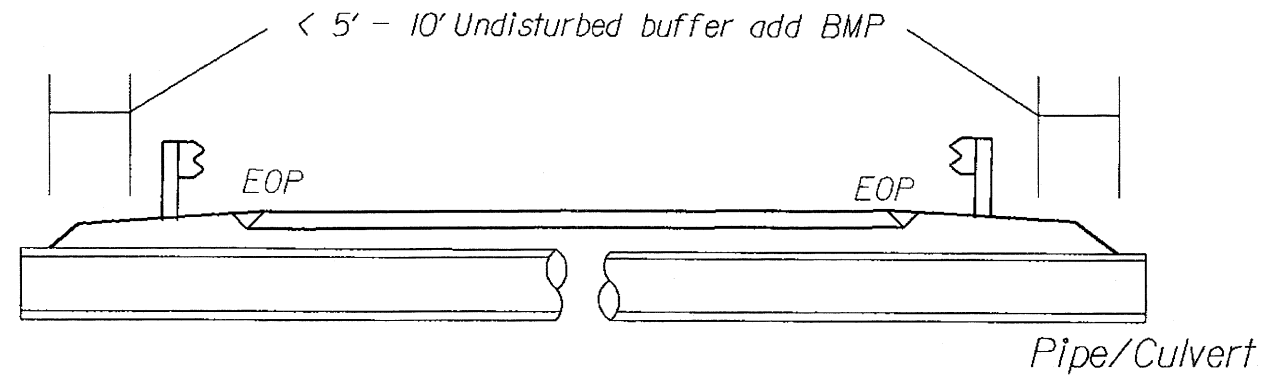

< 5' - 10' Undisturbed buffer from Jurisdictional feature add BMP

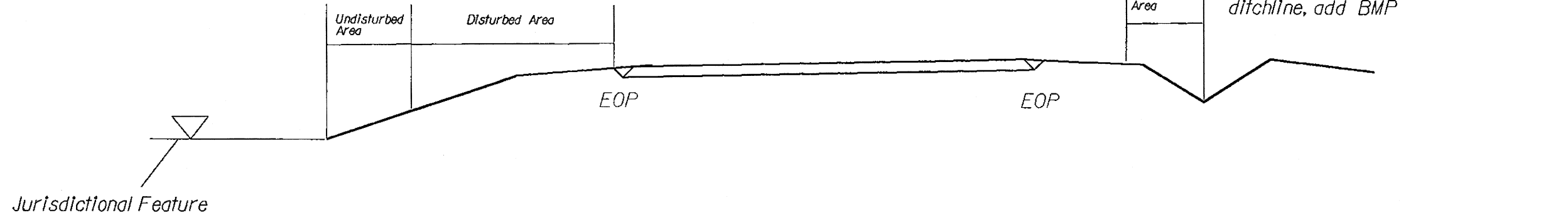

Use BMP's if shoulders and/or frontslopes and/or ditchline and/or backslopes are disturbed

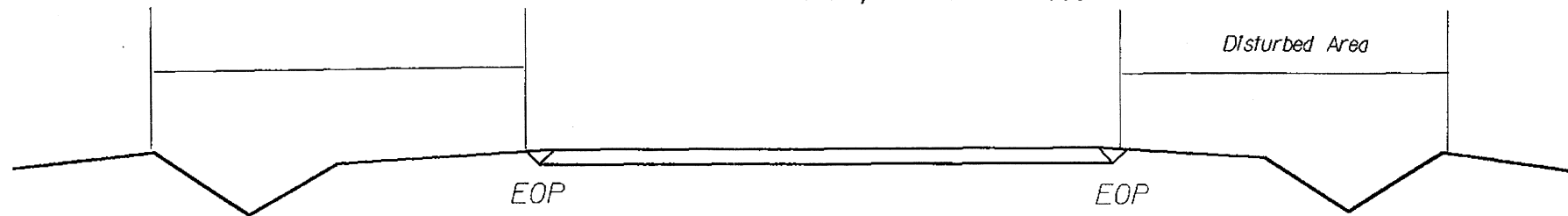

< 5' - 10' Undisturbed buffer from inlet, add wattle

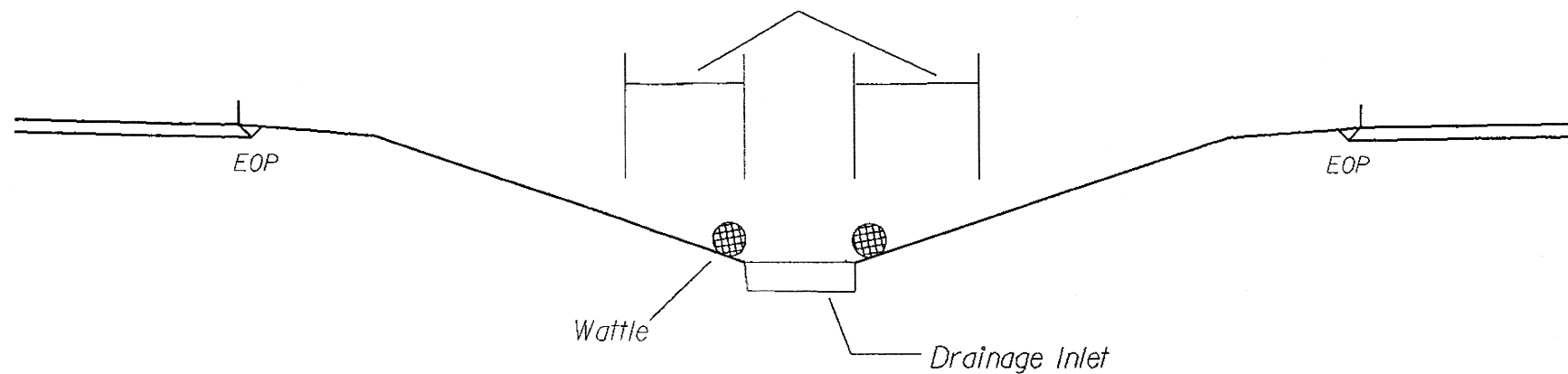

NOT TO SCALE

PROJECT REFERENCE NO. 9CR-10291.150.ETC	SHEET NO. EC-2
ROADWAY DESIGN ENGINEER	HYDRAULICS ENGINEER

WATTLE DETAIL

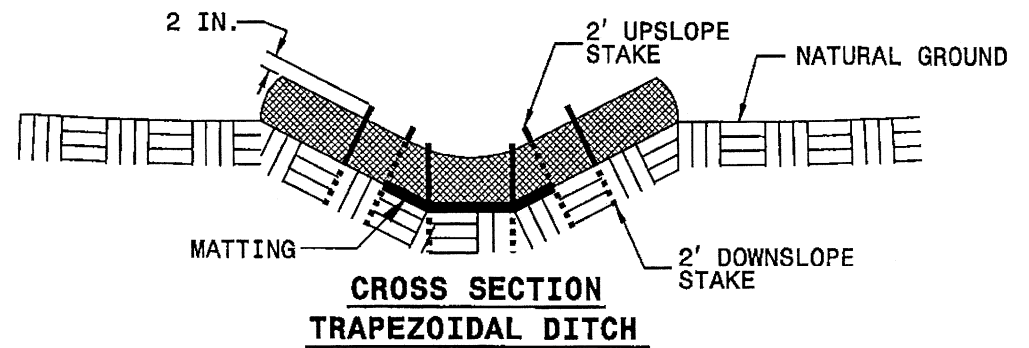
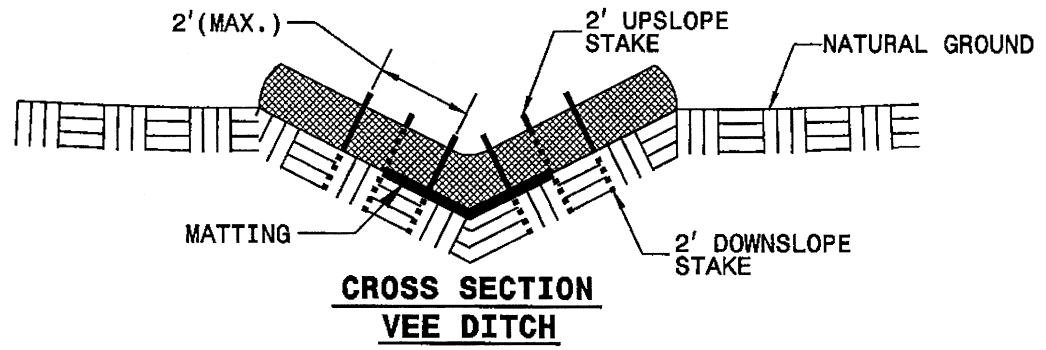
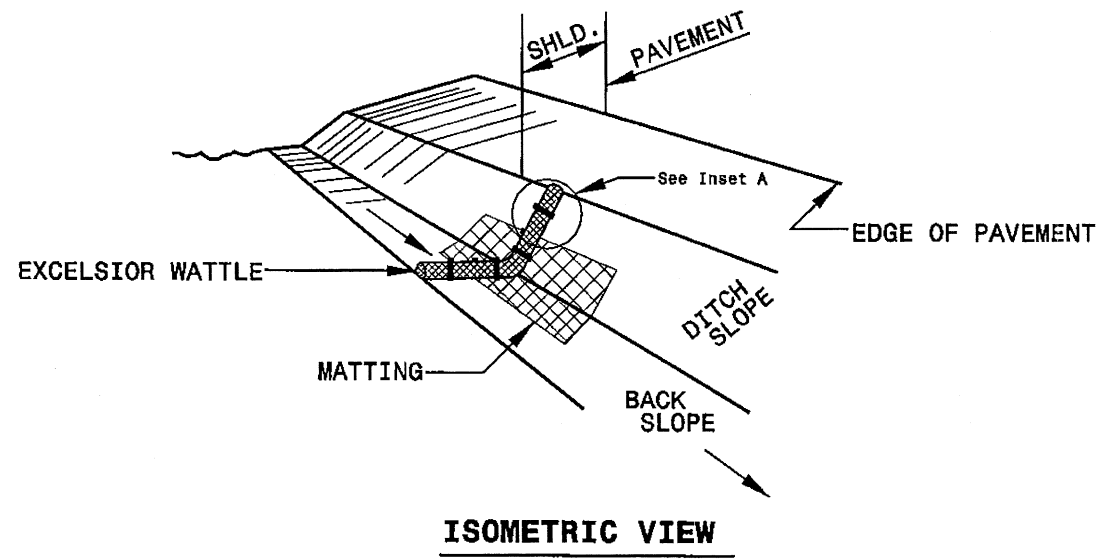

- NOTES:
- USE MINIMUM 12 IN. DIAMETER EXCELSIOR WATTLE.
 - USE 2 FT. WOODEN STAKES WITH A 2 IN. BY 2 IN. NOMINAL CROSS SECTION.
 - ONLY INSTALL WATTLE(S) TO A HEIGHT IN DITCH SO FLOW WILL NOT WASH AROUND WATTLE AND SCOUR DITCH SLOPES AND AS DIRECTED.
 - INSTALL A MINIMUM OF 2 UPSLOPE STAKES AND 4 DOWNSLOPE STAKES AT AN ANGLE TO WEDGE WATTLE TO BOTTOM OF DITCH.
 - PROVIDE STAPLES MADE OF 0.125 IN. DIAMETER STEEL WIRE FORMED INTO A U SHAPE NOT LESS THAN 12" IN LENGTH.
 - INSTALL STAPLES APPROXIMATELY EVERY 1 LINEAR FOOT ON BOTH SIDES OF WATTLE AND AT EACH END TO SECURE IT TO THE SOIL.
 - INSTALL MATTING IN ACCORDANCE WITH SECTION 1631 OF THE STANDARD SPECIFICATIONS.

