

TIP NO.	SHEET NO.
X-0002CC	PMP-1
APPROVED: <i>[Signature]</i>	
DATE: 12-16-13	
SEAL	

**STATE OF NORTH CAROLINA  
DEPARTMENT OF TRANSPORTATION**

**PAVEMENT MARKING PLAN  
CUMBERLAND COUNTY**

**LOCATION: FAYETTEVILLE OUTER LOOP FROM EAST OF NC 210 (MURCHISON RD.) TO US 401**

**CONTRACT: C203361 T.I.P.: X-0002CC**

**ROADWAY STANDARD DRAWING**

THE FOLLOWING ROADWAY STANDARDS AS APPEAR IN "ROADWAY STANDARD DRAWINGS" - PROJECT SERVICES UNIT - N.C. DEPARTMENT OF TRANSPORTATION - RALEIGH, N.C., DATED JANUARY 2012 ARE APPLICABLE TO THIS PROJECT AND BY REFERENCE HEREBY ARE CONSIDERED A PART OF THESE PLANS:

STD. NO.	TITLE
1205.01	PAVEMENT MARKINGS - LINE TYPES AND OFFSETS
1205.02	PAVEMENT MARKINGS - TWO-LANE AND MULTILANE ROADWAYS
1205.03	PAVEMENT MARKINGS - EXIT AND ENTRANCE RAMP
1205.04	PAVEMENT MARKINGS - INTERSECTIONS
1205.05	PAVEMENT MARKINGS - TURN LANES
1205.06	PAVEMENT MARKINGS - LANE DROPS (SHEETS 2 & 3)
1205.08	PAVEMENT MARKINGS - SYMBOLS AND WORD MESSAGES
1205.09	PAVEMENT MARKINGS - PAINTED ISLANDS
1205.12	PAVEMENT MARKINGS - BRIDGES
1205.13	PAVEMENT MARKINGS - LANE REDUCTIONS
1250.01	RAISED PAVEMENT MARKERS - INSTALLATION SPACING
1251.01	RAISED PAVEMENT MARKERS - PERMANENT AND TEMPORARY
1253.01	RAISED PAVEMENT MARKERS - SNOWPLOWABLE
1261.01	GUARDRAIL AND BARRIER DELINEATORS - INSTALLATION SPACING
1261.02	GUARDRAIL AND BARRIER DELINEATORS - TYPES AND MOUNTING
1262.01	GUARDRAIL END DELINEATION
1264.01	OBJECT MARKERS - TYPES
1264.02	OBJECT MARKERS - INSTALLATION
1267.01	FLEXIBLE DELINEATORS - INSTALLATION
1267.02	FLEXIBLE DELINEATORS - SPACING TABLES
1267.03	FLEXIBLE DELINEATORS - INTERCHANGE PLACEMENT

**GENERAL NOTES**

THE FOLLOWING GENERAL NOTES APPLY AT ALL TIMES FOR THE DURATION OF THE CONSTRUCTION PROJECT, EXCEPT WHEN OTHERWISE NOTED IN THE PLAN, OR DIRECTED BY THE ENGINEER.

A) INSTALL PAVEMENT MARKINGS AND PAVEMENT MARKERS ON THE FINAL SURFACE AS FOLLOWS:

ROAD NAME	MARKING	MARKER
-L- LINE & -Y- LINES	THERMOPLASTIC	SNOWPLOWABLE
BRIDGES	POLYUREA	RAISED PERMANENT

B) TIE PROPOSED PAVEMENT MARKING LINES TO EXISTING PAVEMENT MARKING LINES.

C) REMOVE/REPLACE ANY CONFLICTING/DAMAGED PAVEMENT MARKINGS AND MARKERS.

D) PASSING ZONES WILL BE DETERMINED IN THE FIELD AND MUST BE APPROVED BY THE ENGINEER.

E) STOP BAR LOCATION AT NON-SIGNALIZED INTERSECTIONS MAY BE ADJUSTED AS DIRECTED BY THE ENGINEER.

F) REMOVE ALL RESIDUE AND SURFACE LAITANCE BY ACCEPTABLE METHODS ON CONCRETE BRIDGE DECKS PRIOR TO PLACING POLYUREA PAVEMENT MARKING MATERIAL.

G) UNLESS OTHERWISE SPECIFIED, HEATED-IN-PLACE THERMOPLASTIC MAY BE USED IN LIEU OF EXTRUDED THERMOPLASTIC FOR STOP BARS, SYMBOLS, CHARACTERS AND DIAGONALS. IF HEATED-IN-PLACE IS USED, IT SHALL BE PAID FOR USING THE EXTRUDED THERMOPLASTIC PAY ITEM.

**INDEX**

SHEET NO.	DESCRIPTION
PMP-1	PAVEMENT MARKING PLAN TITLE SHEET
PMP-1A	REVISE PAVEMENT MARKING ROADWAY STANDARD DRAWING 1205.06 SHEET 1
PMP-2	PAVEMENT MARKING SCHEDULE
PMP-3 thru 24	PAVEMENT MARKING DETAIL

PLAN PREPARED BY: N.C.D.O.T. SIGNING AND DELINEATION UNIT

A.I.A.L.Q.U.D.W.A.H., P.E. SIGNING & DELINEATION REGIONAL ENGINEER

M.EATON SIGNING & DELINEATION PROJECT DESIGN ENGINEER/TECHNICIAN

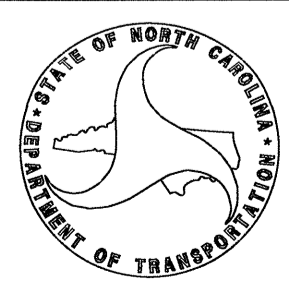

TIP NO. X-0002CC	SHEET NO. PMP-1A
APPROVED: <i>[Signature]</i>	
DATE: 10-28-13	
SEAL	

STATE OF NORTH CAROLINA  
 DEPT. OF TRANSPORTATION  
 DIVISION OF HIGHWAYS  
 RALEIGH, N.C.

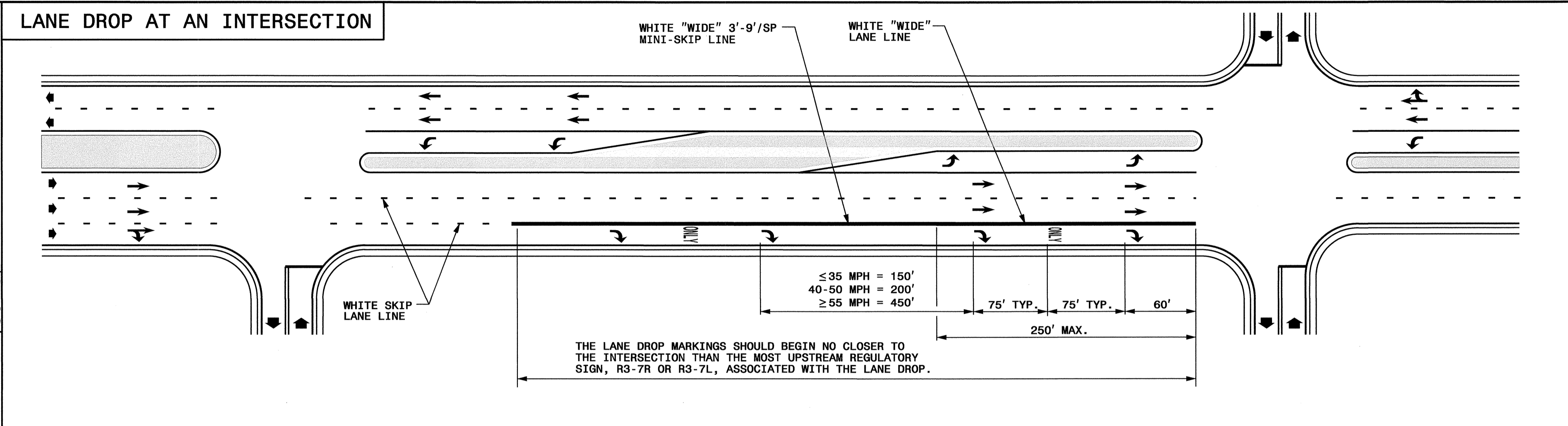

STATE OF NORTH CAROLINA  
 DEPT. OF TRANSPORTATION  
 DIVISION OF HIGHWAYS  
 RALEIGH, N.C.

ENGLISH DETAIL DRAWING FOR  
**PAVEMENT MARKINGS**  
 LANE DROPS

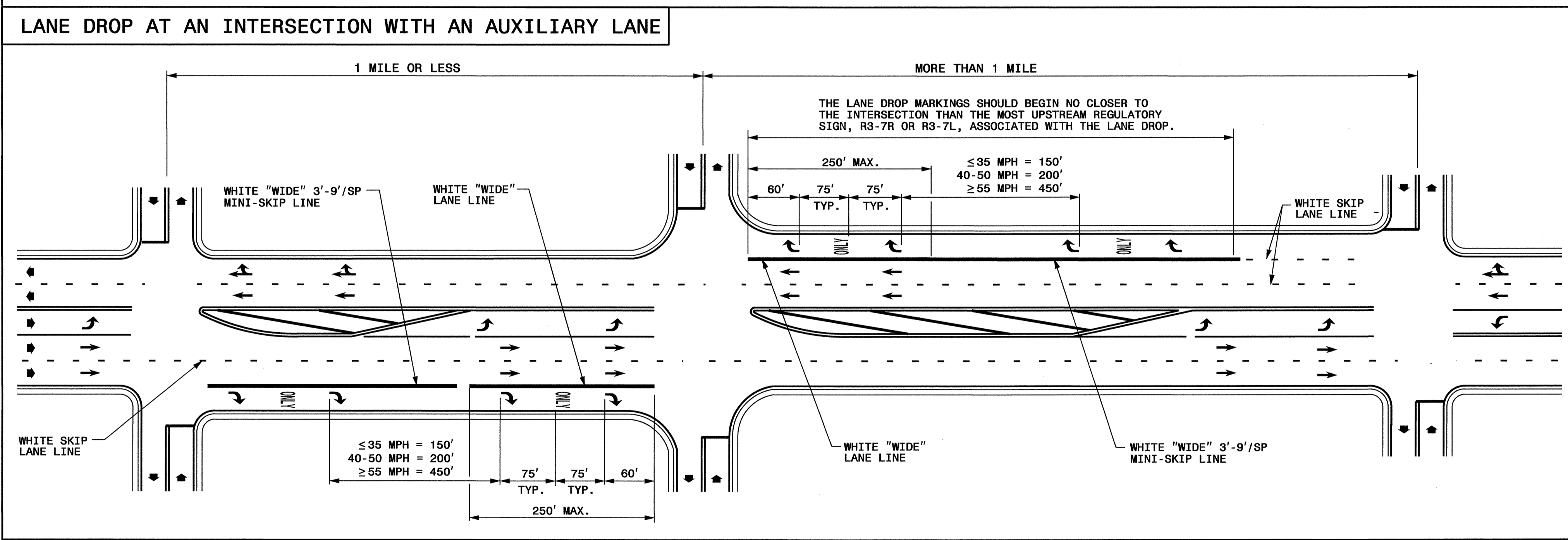

ENGLISH DETAIL DRAWING FOR  
**PAVEMENT MARKINGS**  
 LANE DROPS

- GENERAL NOTES:**
- USE THE GUIDANCE SHOWN ON THE ABOVE DETAILS IN CONJUNCTION WITH INTERSECTION GUIDANCE SHOWN ON ROADWAY STANDARD DRAWING 1205.04.
  - LANE LINES INDICATED AS "WIDE" SHALL BE AT LEAST TWICE THE WIDTH OF THE NORMAL LINE.



LEGEND	
W = WHITE "WIDE" 3'-9"/SP MINI-SKIP LINE	ONLY PAVEMENT MARKING SYMBOLS & CHARACTERS
➔ DIRECTION OF TRAFFIC FLOW	

SHEET 1 OF 3  
**1205.06**

SHEET 1 OF 3  
**1205.06**

**REVISED PAVEMENT MARKING  
ROADWAY STANDARD DRAWING**

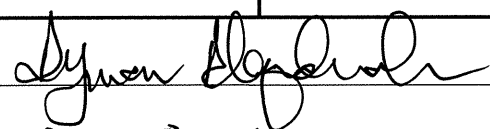
15-OCT-2013 11:37 AM  
 P:\TIPPs\01e\13\X00028B\T-r\offic\Signing\CADD\Signing Layout Plans\2ec\X0002CC\_Pmp-1\file.dgn  
 mecton ATT:TE274922

TIP NO.	SHEET NO.
X-0002CC	PMP-2
APPROVED: 	
DATE: 10-28-13	
SEAL	
	

### FINAL PAVEMENT MARKING SCHEDULE

#### PAVEMENT MARKINGS

<p>THERMOPLASTIC(100mm, 90 MILS)</p> <p>TA WHITE EDGELINE</p> <p>THERMOPLASTIC(100mm", 120 MILS)</p> <p>T8 0.6M WHITE MINISKIP</p> <p>TC 3.0M WHITE SKIP</p> <p>TD 0.9M WHITE MINISKIP</p> <p>TE WHITE SOLID LANE LINE</p> <p>THERMOPLASTIC(150mm, 90 MILS)</p> <p>T6 WHITE EDGELINE</p> <p>T7 YELLOW EDGELINE</p> <p>THERMOPLASTIC(150mm, 120 MILS)</p> <p>TJ 3.0M WHITE SKIP</p> <p>TK 0.9M WHITE MINISKIP</p> <p>TL WHITE SOLID LANE LINE</p> <p>THERMOPLASTIC(200mm, 90 MILS)</p> <p>TN WHITE GORELINE</p> <p>THERMOPLASTIC(300mm, 90 MILS)</p> <p>TS WHITE GORELINE</p> <p>THERMOPLASTIC(300mm, 120 MILS)</p> <p>TT WHITE SOLID LANE LINE</p> <p>THERMOPLASTIC(600mm, 120 MILS)</p> <p>T2 WHITE STOPBAR</p> <p>THERMOPLASTIC PAVEMENT MARKING CHARACTER (120 MILS)</p> <p>UI ALPHANUMERIC CHAR.</p> <p>THERMOPLASTIC PAVEMENT MARKING SYMBOLS (90 MILS)</p> <p>UA LEFT TURN ARROW</p> <p>UB RIGHT TURN ARROW</p> <p>UP MERGE ARROW</p>	<p>POLYUREA(150mm) HIGHLY REFLECTIVE ELEMENTS</p> <p>V6 WHITE EDGELINE</p> <p>V7 YELLOW EDGELINE</p> <p>VJ 10 FT. WHITE SKIP</p> <p>VK 900mm - 2.7m/SP WHITE MINISKIP</p>
--	---

### FINAL PAVEMENT MARKERS SCHEDULE

#### MARKERS

#### SNOWPLOWABLE RAISED PAVEMENT MARKERS

ME	YELLOW & YELLOW
MF	CRYSTAL & RED

#### RAISED PAVEMENT MARKERS

MB	CRYSTAL & RED
----	---------------

**PAVEMENT MARKING AND  
MARKER SCHEDULE**







TIP NO. X-0002CC	SHEET NO. PMP-4
APPROVED: <i>[Signature]</i>	
DATE: 11-1-13	
SEAL	

**SYMBOL AND PAVEMENT MARKING LEGEND**

(UB) RIGHT TURN ARROW      ONLY (UI) ALPHANUMERIC CHARACTER

**THERMOPLASTIC**

(T7) YELLOW EDGE LINE (150mm)      (TE) WHITE SOLID LANE LINE (100mm)  
 (TA) WHITE EDGE LINE (100mm)

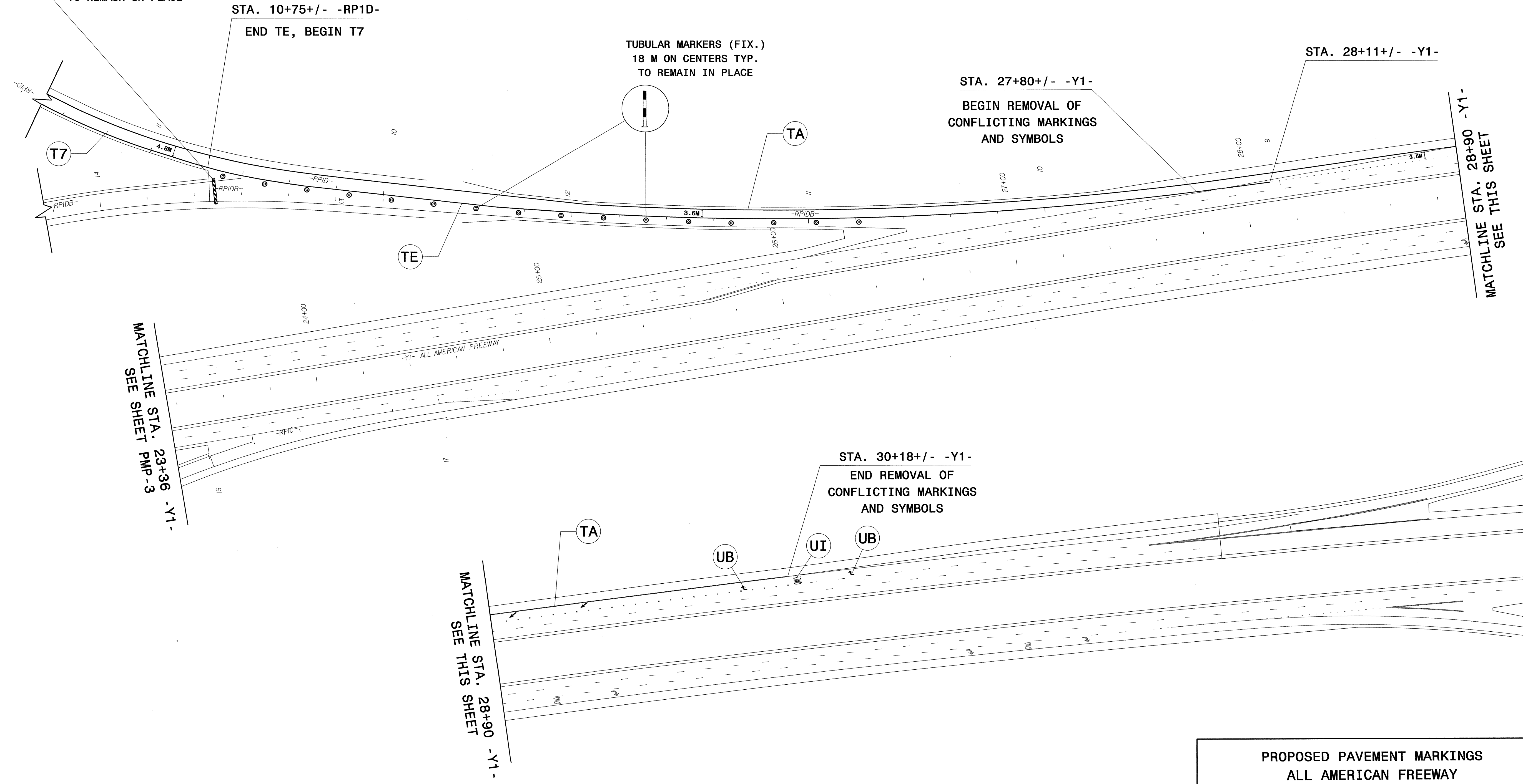
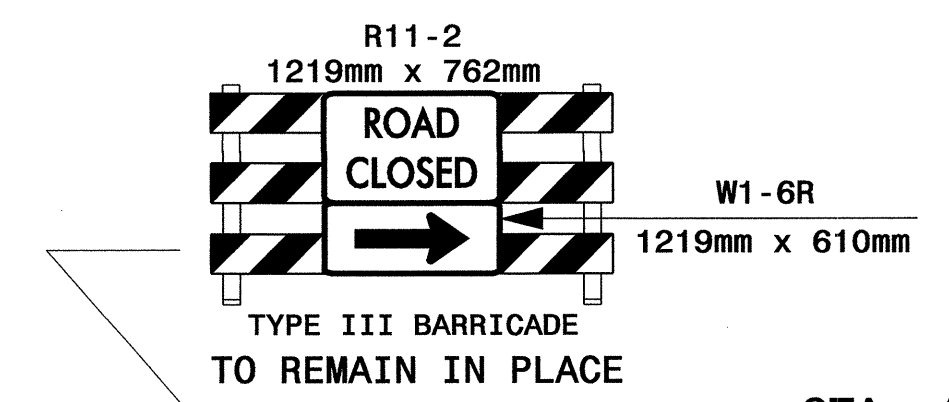

**PROPOSED PAVEMENT MARKINGS  
ALL AMERICAN FREEWAY  
STA. 23+36 -Y1- TO STA. 28+90 -Y1-**

30-OCT-2013 14:23 P:\PMP-0002CC\Traffic\Signing\CADD\Signing Layout\Plans\2cc\2cc.pmp.psh02.dgn







TIP NO. X-0002CC	SHEET NO. PMP-6
APPROVED: <i>[Signature]</i>	
DATE: 11-1-13	
SEAL	

SYMBOL AND PAVEMENT MARKING LEGEND			
	UB	RIGHT TURN ARROW	ONLY
	UI	ALPHANUMERIC CHARACTER	
	UP	MERGE ARROW	
THERMOPLASTIC			
	T6	WHITE EDGE LINE (150mm)	
	T7	YELLOW EDGE LINE (150mm)	
	TJ	WHITE SKIP LINE (150mm)	
	TK	0.9m - 2.7m WHITE MINISKIP (150mm)	
	TS	WHITE GORELINE (300mm)	
	TT	WHITE SOLID LANE LINE (300mm)	
POLYUREA			
	V6	WHITE EDGE LINE (150mm)	
	V7	YELLOW EDGE LINE (150mm)	
	VJ	WHITE SKIP LINE (150mm)	
	VK	0.9m - 2.7m WHITE MINISKIP (150mm)	

TUBULAR MARKERS (FIX.)  
18 M ON CENTERS TYP.  
TO REMAIN IN PLACE

MATCHLINE STA. 30+50 -L-  
SEE SHEET PMP-3

MATCHLINE STA. 36+40 -L-  
SEE SHEET PMP-7

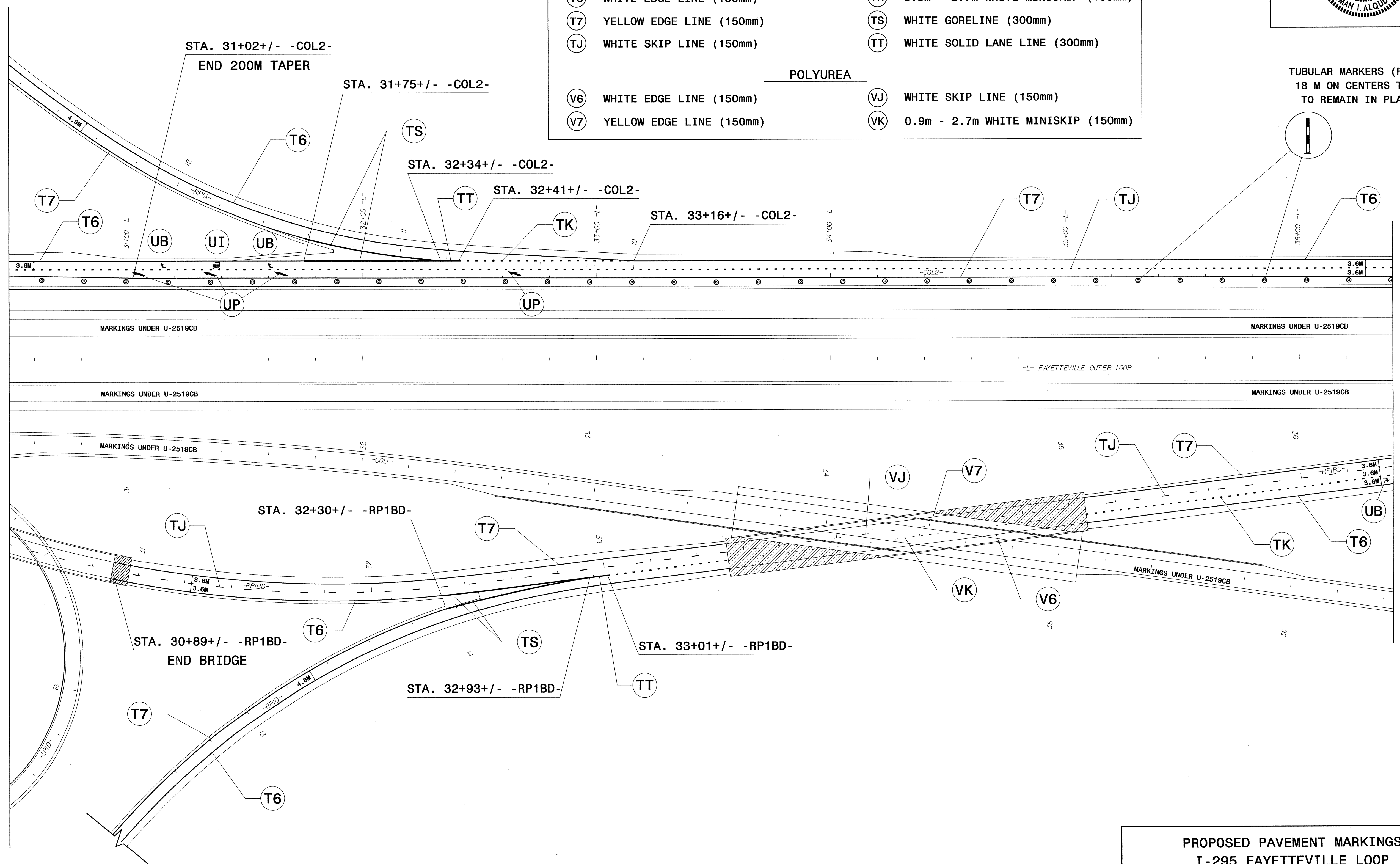

PROPOSED PAVEMENT MARKINGS  
I-295 FAYETTEVILLE LOOP  
STA. 30+50 -L- TO STA. 36+40 -L-

30-OCT-2013 14:38 X:\0002CC\Traffic\Signing\CADD\Signing Layout Plans\2cc\pmp-fah04.dgn  
mabon



TIP NO. X-0002CC SHEET NO. PMP-7  
 APPROVED: *[Signature]*  
 DATE: 11-1-13

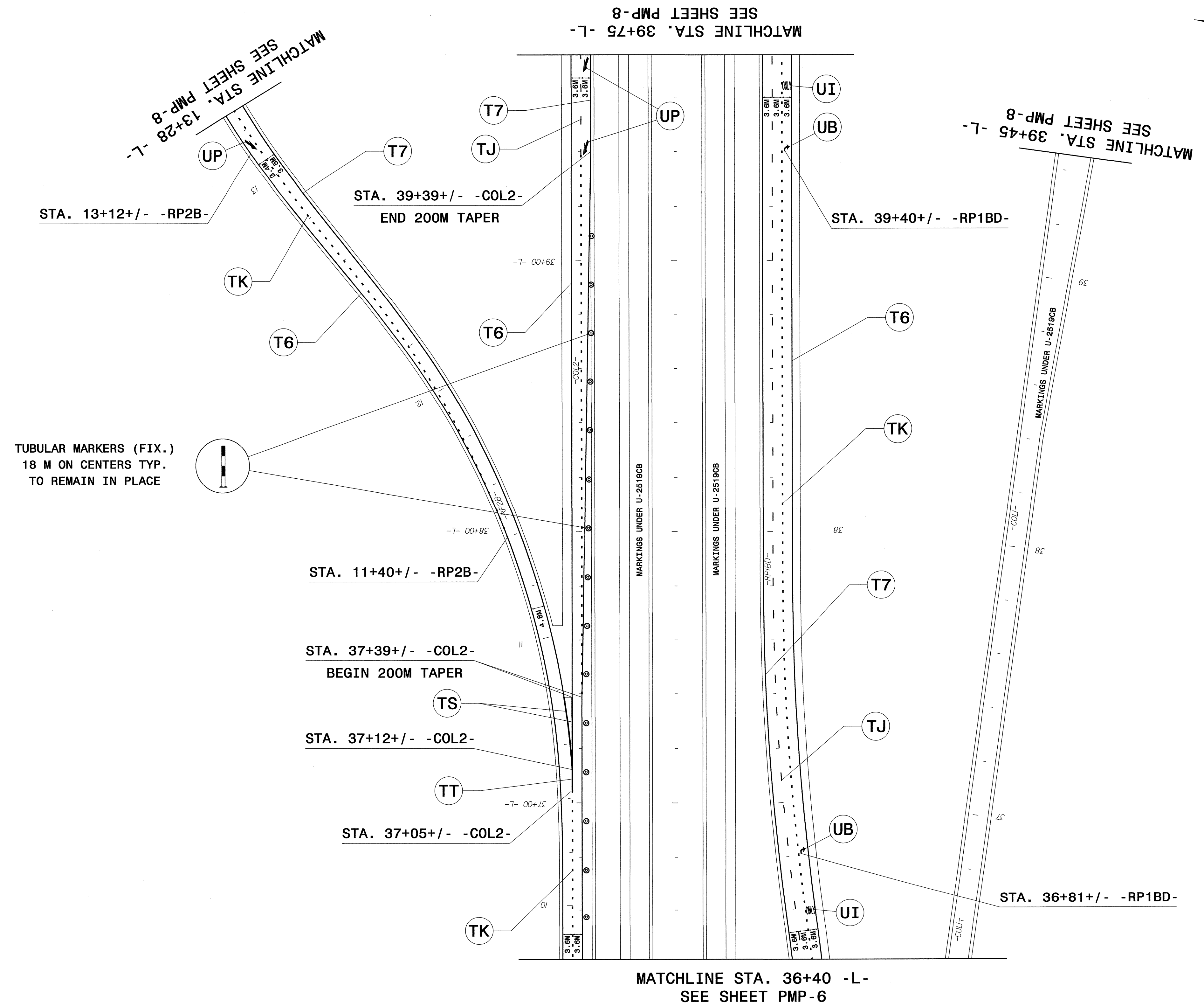
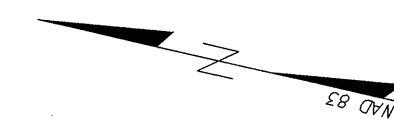
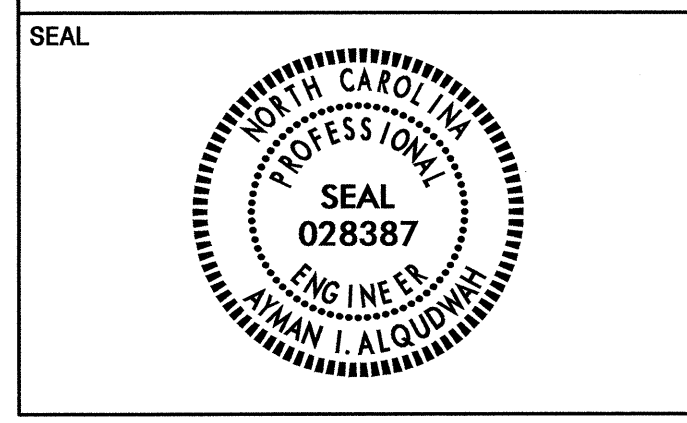

TUBULAR MARKERS (FIX.)  
 18 M ON CENTERS TYP.  
 TO REMAIN IN PLACE

SYMBOL AND PAVEMENT MARKING LEGEND	
	UB RIGHT TURN ARROW
	ONLY UI ALPHANUMERIC CHARACTER
	UP MERGE ARROW
THERMOPLASTIC	
T2	WHITE STOPBAR (610mm)
T6	WHITE EDGE LINE (150mm)
T7	YELLOW EDGE LINE (150mm)
TJ	WHITE SKIP LINE (150mm)
TK	0.9m - 2.7m WHITE MINISKIP (150mm)
TS	WHITE GORELINE (300mm)
TT	WHITE SOLID LANE LINE (300mm)

PROPOSED PAVEMENT MARKINGS  
 I-295 FAYETTEVILLE LOOP  
 STA. 36+40 -L- TO STA. 39+75 -L-

30-OCT-2013 14:41 \\s000255\Traffic\Signing\CHDD\Signing Layout Plans\2cc\2cc.pmp.psh05.dgn  
 1





TIP NO. X-0002CC SHEET NO. PMP-8  
 APPROVED: *[Signature]*  
 DATE: 11-1-13

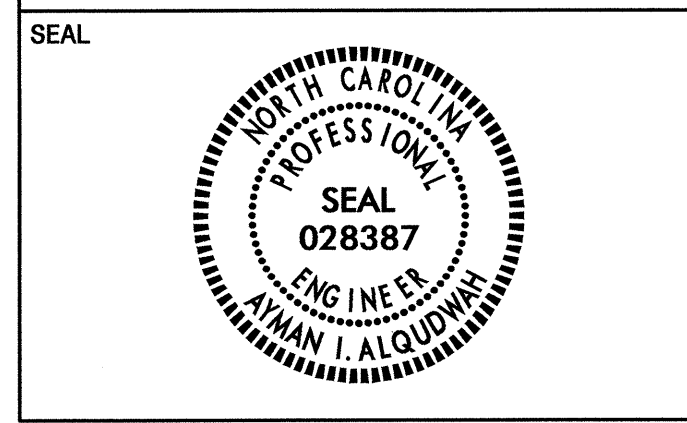

SYMBOL AND PAVEMENT MARKING LEGEND					
	UA	LEFT TURN ARROW		UB	RIGHT TURN ARROW
	UP	MERGE ARROW			
THERMOPLASTIC					
T2	WHITE STOPBAR (610mm)	TE	WHITE SOLID LANE LINE (100mm)		
T6	WHITE EDGE LINE (150mm)	TJ	WHITE SKIP LINE (150mm)		
T7	YELLOW EDGE LINE (150mm)	TK	0.9m - 2.7m WHITE MINISKIP (150mm)		
T8	0.6m - 1.8m WHITE MINISKIP (100mm)	TL	WHITE SOLID LANE LINE (150mm)		
TA	WHITE EDGE LINE (100mm)	TN	WHITE GORELINE (200mm)		
TC	WHITE SKIP LINE (100mm)	TS	WHITE GORELINE (300mm)		
TD	0.9m - 2.7m WHITE MINISKIP (100mm)	TT	WHITE SOLID LANE LINE (300mm)		
POLYUREA					
V6	WHITE EDGE LINE (150mm)	VJ	WHITE SKIP LINE (150mm)		
V7	YELLOW EDGE LINE (150mm)	VK	0.9m - 2.7m WHITE MINISKIP (150mm)		

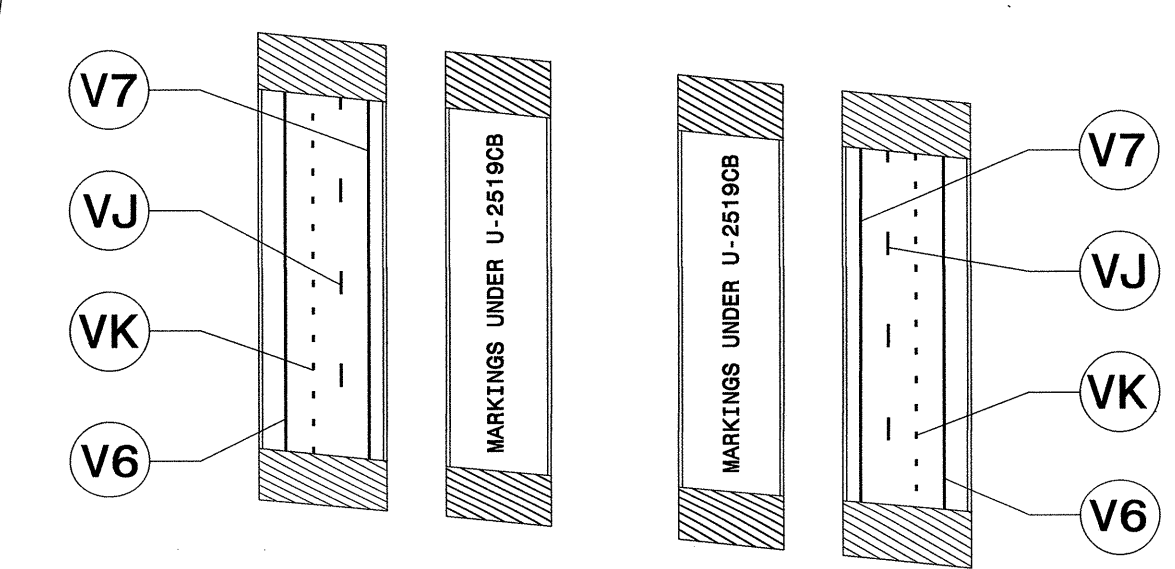
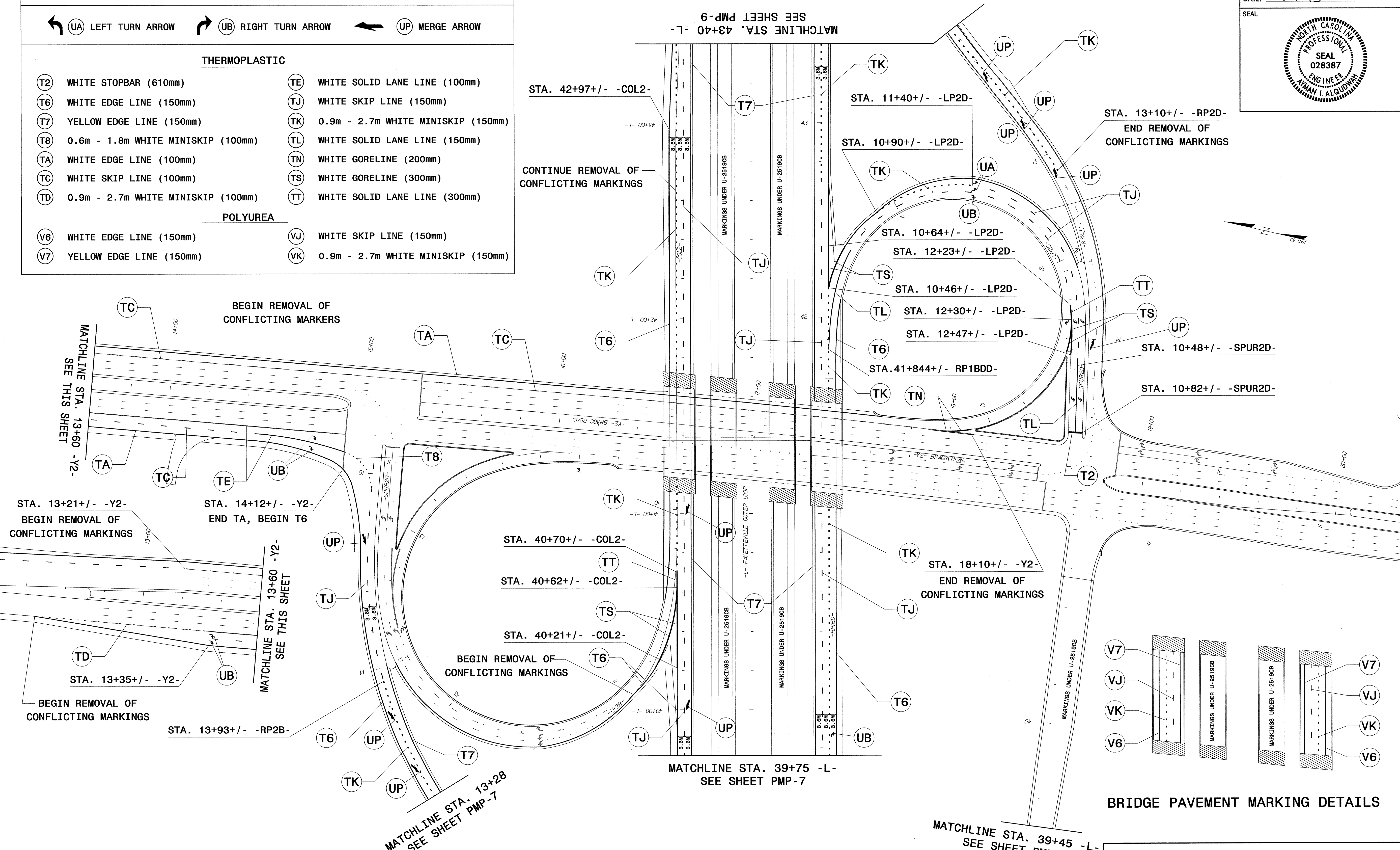

BRIDGE PAVEMENT MARKING DETAILS

PROPOSED PAVEMENT MARKINGS  
 I-295 FAYETTEVILLE LOOP  
 STA. 39+75 -L- TO STA. 43+40 -L-

30-061-2013 14:44  
 I:\Projects\2013\1444\I-295\Traffic\Signing\CADD\Signing Layout Plans\2cc\2cc\pmp\_pah06.dgn  
 11/1/13 10:00 AM  
 11/1/13 10:00 AM



TIP NO. X-0002CC SHEET NO. PMP-9  
 APPROVED: *[Signature]*  
 DATE: 11-1-13

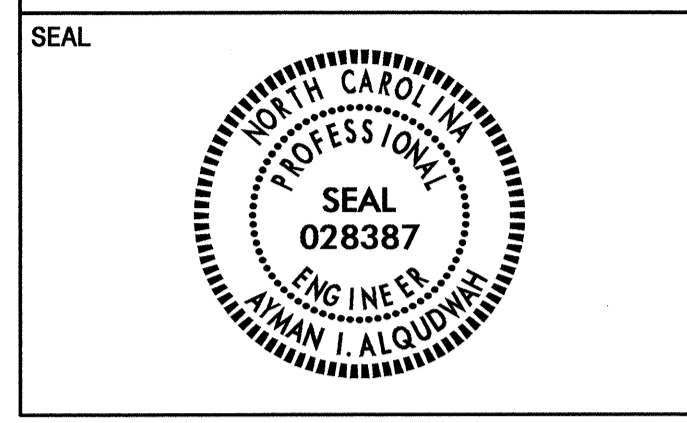

SYMBOL AND PAVEMENT MARKING LEGEND					
	UA	LEFT TURN ARROW	ONLY UI ALPHANUMERIC CHARACTER		
THERMOPLASTIC					
	T6	WHITE EDGE LINE (150mm)		TK	0.9m - 2.7m WHITE MINISKIP (150mm)
	T7	YELLOW EDGE LINE (150mm)		TS	WHITE GORELINE (300mm)
	TJ	WHITE SKIP LINE (150mm)		TT	WHITE SOLID LANE LINE (300mm)

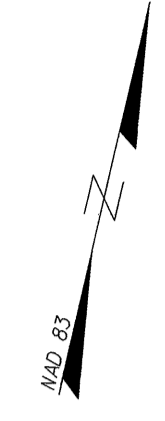

TUBULAR MARKERS (FIX.)  
 18 M ON CENTERS TYP.  
 TO REMAIN IN PLACE

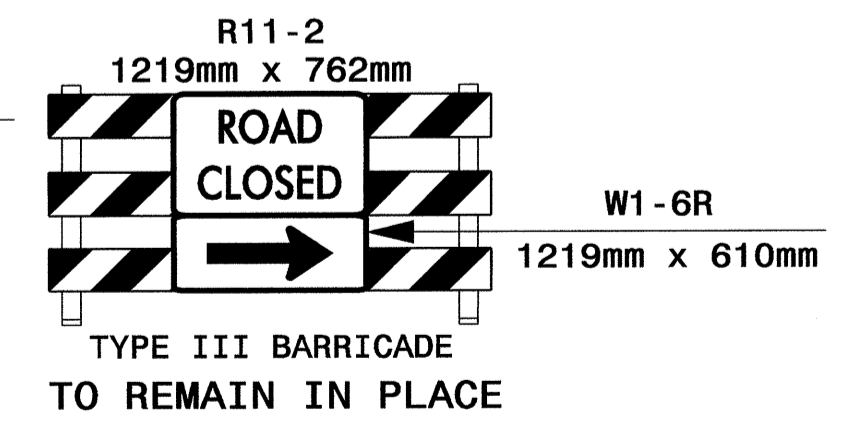
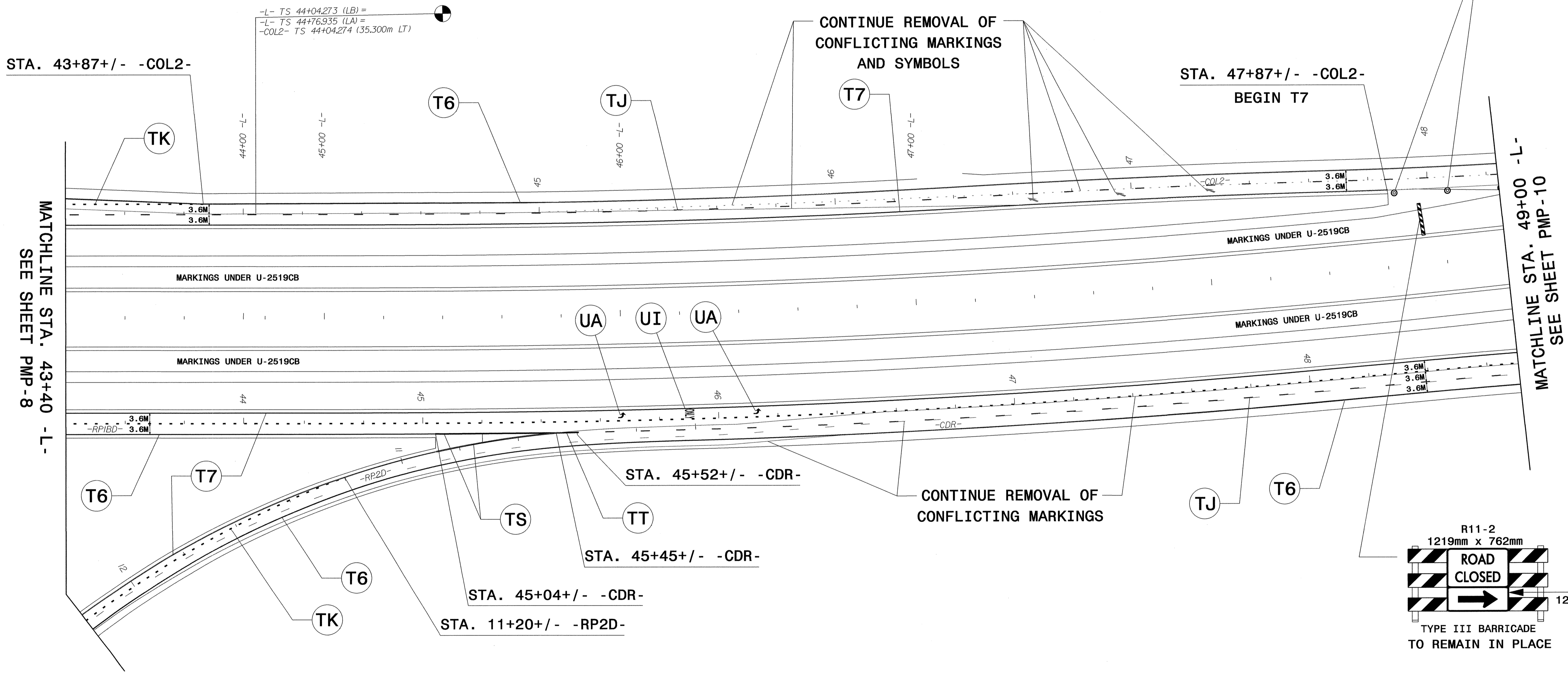

**PROPOSED PAVEMENT MARKINGS**  
 I-295 FAYETTEVILLE LOOP  
 STA. 43+40 -L- TO STA. 49+00 -L-

30-OCT-2013 14:48 \\p00288\Traffic\Signing\CADD\Signing Layout Plans\2cc\2cc.pmp.pah07.dgn  
 P:\00288\Traffic\Signing\CADD\Signing Layout Plans\2cc\2cc.pmp.pah07.dgn



TIP NO. X-0002CC SHEET NO. PMP-10  
 APPROVED: *[Signature]*  
 DATE: 11-1-13

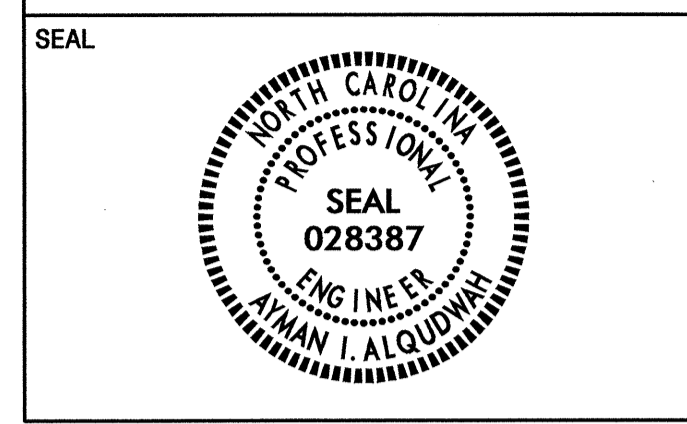

SYMBOL AND PAVEMENT MARKING LEGEND			
(UA)	LEFT TURN ARROW	ONLY (UI)	ALPHANUMERIC CHARACTER
(UP)	MERGE ARROW		
THERMOPLASTIC			
(T6)	WHITE EDGE LINE (150mm)	(TK)	0.9m - 2.7m WHITE MINISKIP (150mm)
(T7)	YELLOW EDGE LINE (150mm)	(TS)	WHITE GORELINE (300mm)
(TJ)	WHITE SKIP LINE (150mm)		

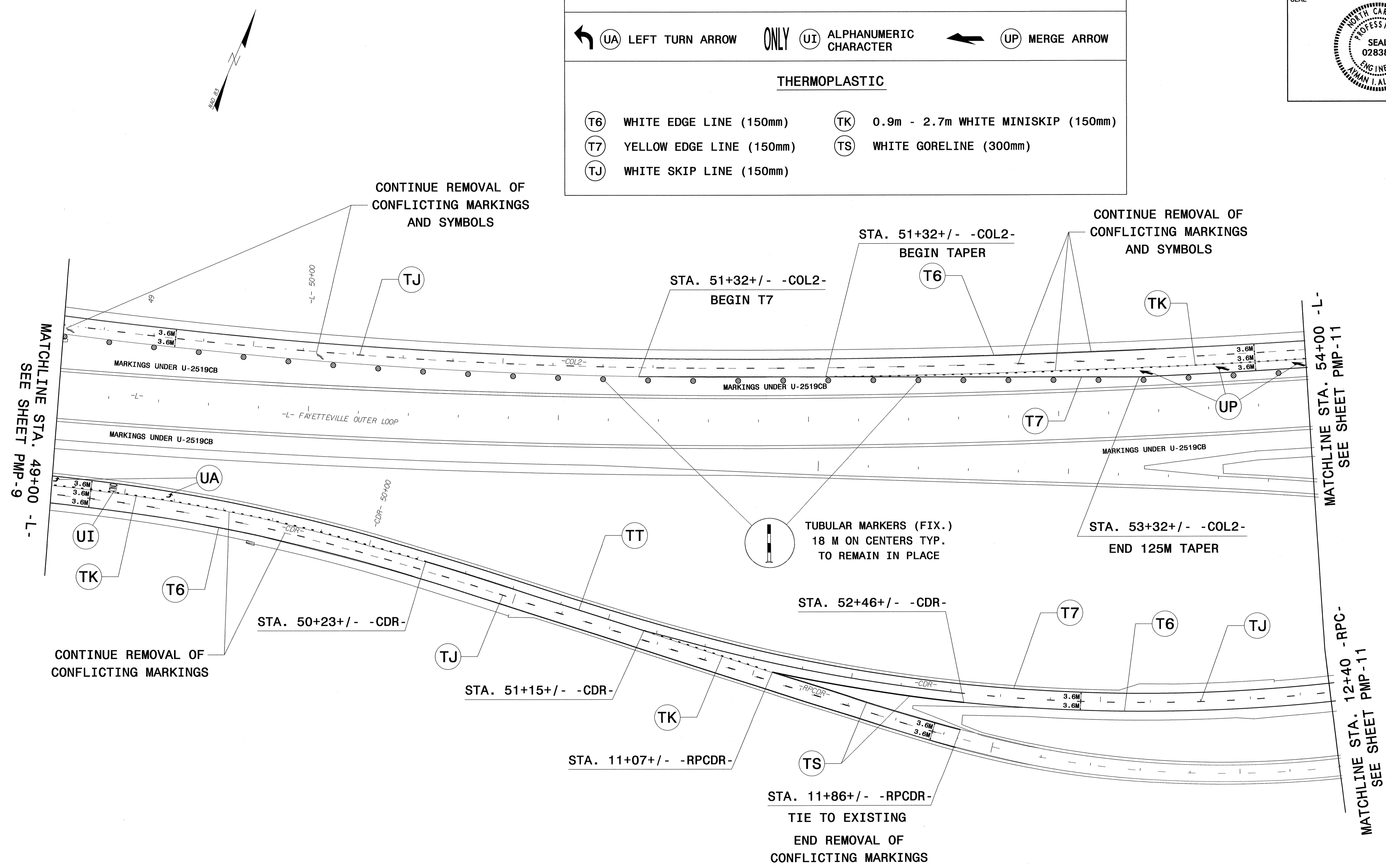

MATCHLINE STA. 49+00 -L-  
SEE SHEET PMP-9

MATCHLINE STA. 54+00 -L-  
SEE SHEET PMP-11

MATCHLINE STA. 12+40 -RPC-  
SEE SHEET PMP-11

PROPOSED PAVEMENT MARKINGS  
 I-295 FAYETTEVILLE LOOP  
 STA. 49+00 -L- TO STA. 54+00 -L-

30-OCT-2013 14:50  
 P:\TIP\pmp-10\130928B Traffic\Signing\CADD\Signing Layout Plans\2cc\2cc.pmp-psh08.dgn  
 03/08/13 11:22:13





TIP NO. X-0002CC SHEET NO. PMP-11  
 APPROVED: *[Signature]*  
 DATE: 11-1-13

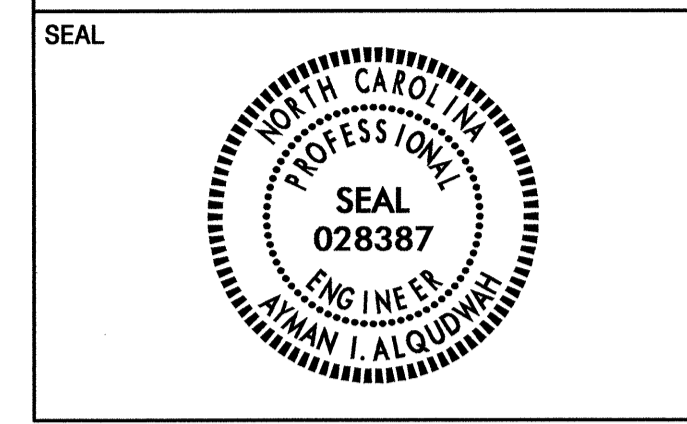

SYMBOL AND PAVEMENT MARKING LEGEND			
(UP) MERGE ARROW			
THERMOPLASTIC			
(T6)	WHITE EDGE LINE (150mm)	(TJ)	WHITE SKIP LINE (150mm)
(T7)	YELLOW EDGE LINE (150mm)	(TK)	0.9m - 2.7m WHITE MINISKIP (150mm)
POLYUREA			
(V6)	WHITE EDGE LINE (150mm)	(VJ)	WHITE SKIP LINE (150mm)
(V7)	YELLOW EDGE LINE (150mm)	(VK)	0.9m - 2.7m WHITE MINISKIP (150mm)

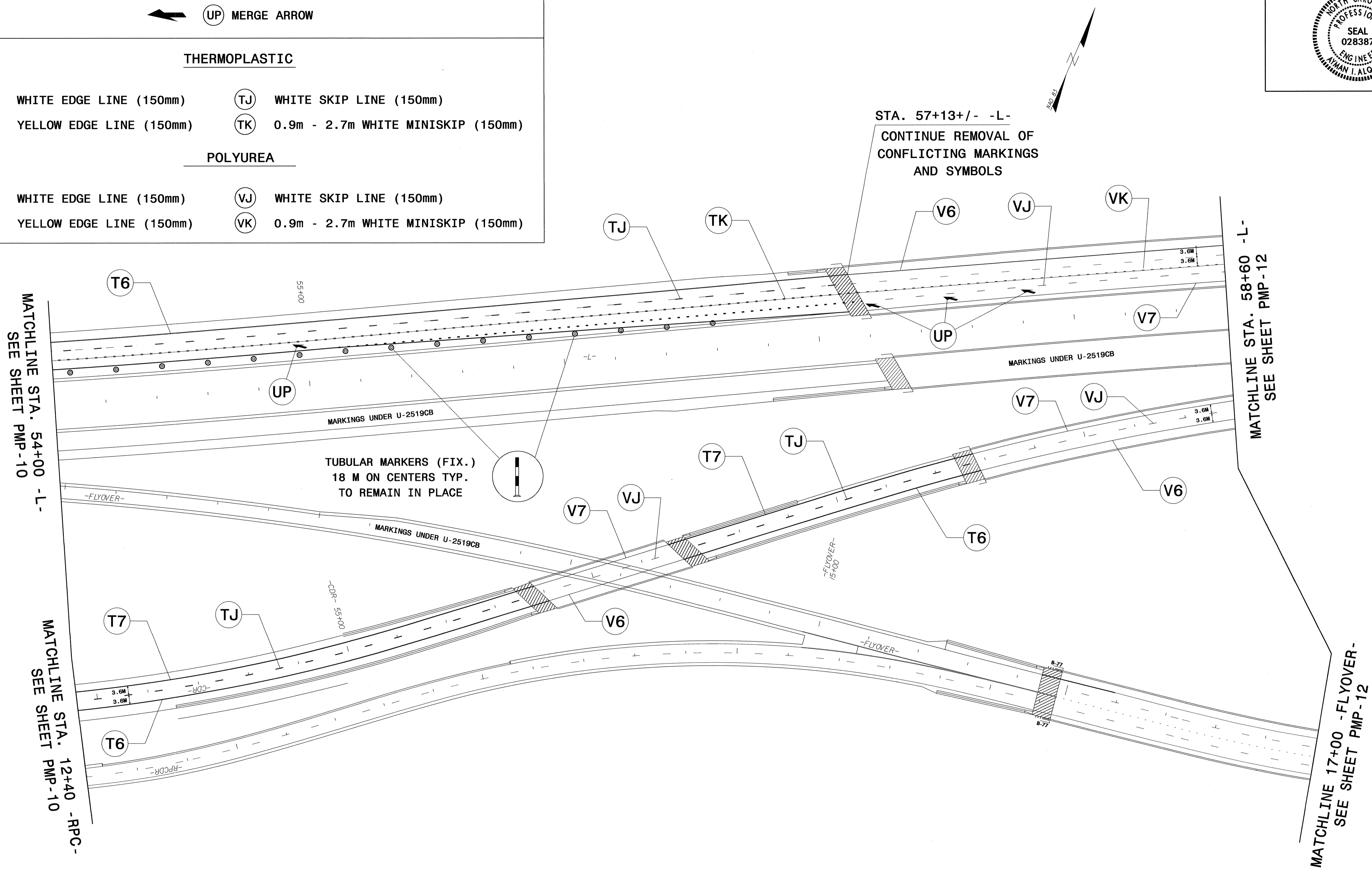

STA. 57+13+/- -L-  
 CONTINUE REMOVAL OF  
 CONFLICTING MARKINGS  
 AND SYMBOLS

MATCHLINE STA. 54+00 -L-  
 SEE SHEET PMP-10

MATCHLINE STA. 58+60 -L-  
 SEE SHEET PMP-12

MATCHLINE STA. 12+40 -RPC-  
 SEE SHEET PMP-10

MATCHLINE 17+00 -FLYOVER-  
 SEE SHEET PMP-12

PROPOSED PAVEMENT MARKINGS  
 I-295 FAYETTEVILLE LOOP  
 STA. 54+00 -L- TO STA. 58+60 -L-

30-OCT-2013 15:29  
 P:\TIP\Projects\028387\X-0002CC\Signing\_Layout\Plans\2cc\pmp-11.dgn  
 meacon -A1 11/2/13



TIP NO. X-0002CC	SHEET NO. PMP-12
APPROVED: <i>[Signature]</i>	
DATE: 10-28-13	
SEAL	

SYMBOL AND PAVEMENT MARKING LEGEND	
THERMOPLASTIC	
(T6)	WHITE EDGE LINE (150mm)
(T7)	YELLOW EDGE LINE (150mm)
(TJ)	WHITE SKIP LINE (150mm)
(TK)	0.9m - 2.7m WHITE MINISKIP (150mm)
(TS)	WHITE GORELINE (300mm)
POLYUREA	
(V6)	WHITE EDGE LINE (150mm)
(V7)	YELLOW EDGE LINE (150mm)
(VJ)	WHITE SKIP LINE (150mm)
(VK)	0.9m - 2.7m WHITE MINISKIP (150mm)

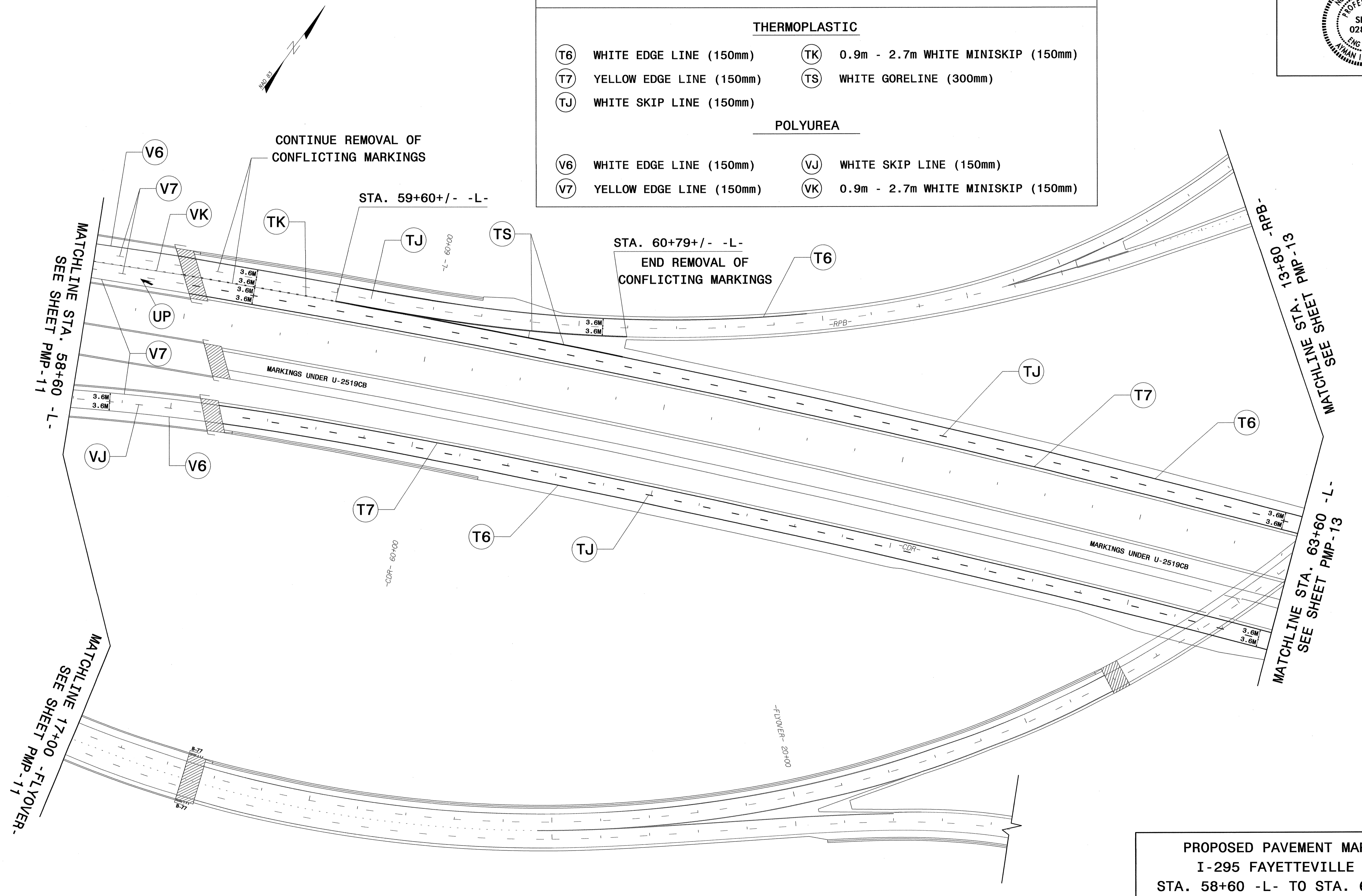

**PROPOSED PAVEMENT MARKINGS**  
**I-295 FAYETTEVILLE LOOP**  
**STA. 58+60 -L- TO STA. 63+60 -L-**

I:\01\2013\0854\15\TIP\0002CC\X-0002CC\Signing\CADD\Signing\_Layout\_Plane\X2cc\X2cc\_pmp.pah10.dgn  
 10/28/13 08:54  
 I:\01\2013\0854\15\TIP\0002CC\X-0002CC\Signing\_Layout\_Plane\X2cc\X2cc\_pmp.pah10.dgn



TIP NO. X-0002CC SHEET NO. PMP-13  
 APPROVED: *[Signature]*  
 DATE: 10-28-13

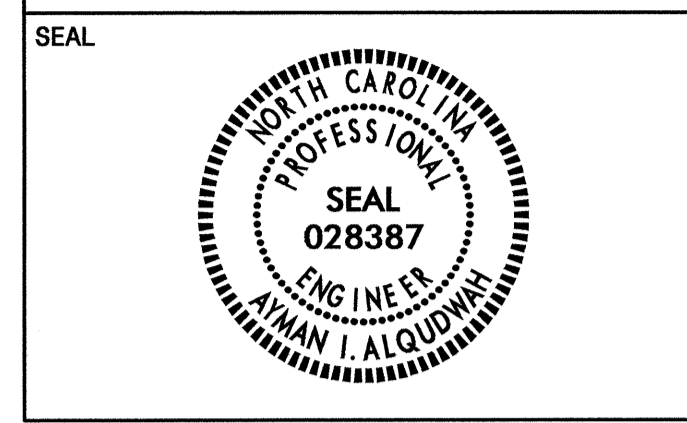

SYMBOL AND PAVEMENT MARKING LEGEND			
(UA)	LEFT TURN ARROW	(UP)	MERGE ARROW
(UB)	RIGHT TURN ARROW	(UI)	ALPHANUMERIC CHARACTER
THERMOPLASTIC			
(T2)	WHITE STOPBAR (600mm)	(TJ)	WHITE SKIP LINE (150mm)
(T6)	WHITE EDGE LINE (150mm)	(TK)	0.9m - 2.7m WHITE MINISKIP (150mm)
(T7)	YELLOW EDGE LINE (150mm)	(TL)	WHITE SOLID LANE LINE (150mm)
(TD)	0.9m - 2.7m WHITE MINISKIP (100mm)	(TS)	WHITE GORELINE (300mm)
(TE)	WHITE SOLID LANE LINE (100mm)	(TT)	WHITE SOLID LANE LINE (300mm)
POLYUREA			
(V6)	WHITE EDGE LINE (150mm)	(VJ)	WHITE SKIP LINE (150mm)
(V7)	YELLOW EDGE LINE (150mm)	(VK)	0.9m - 2.7m WHITE MINISKIP (150mm)

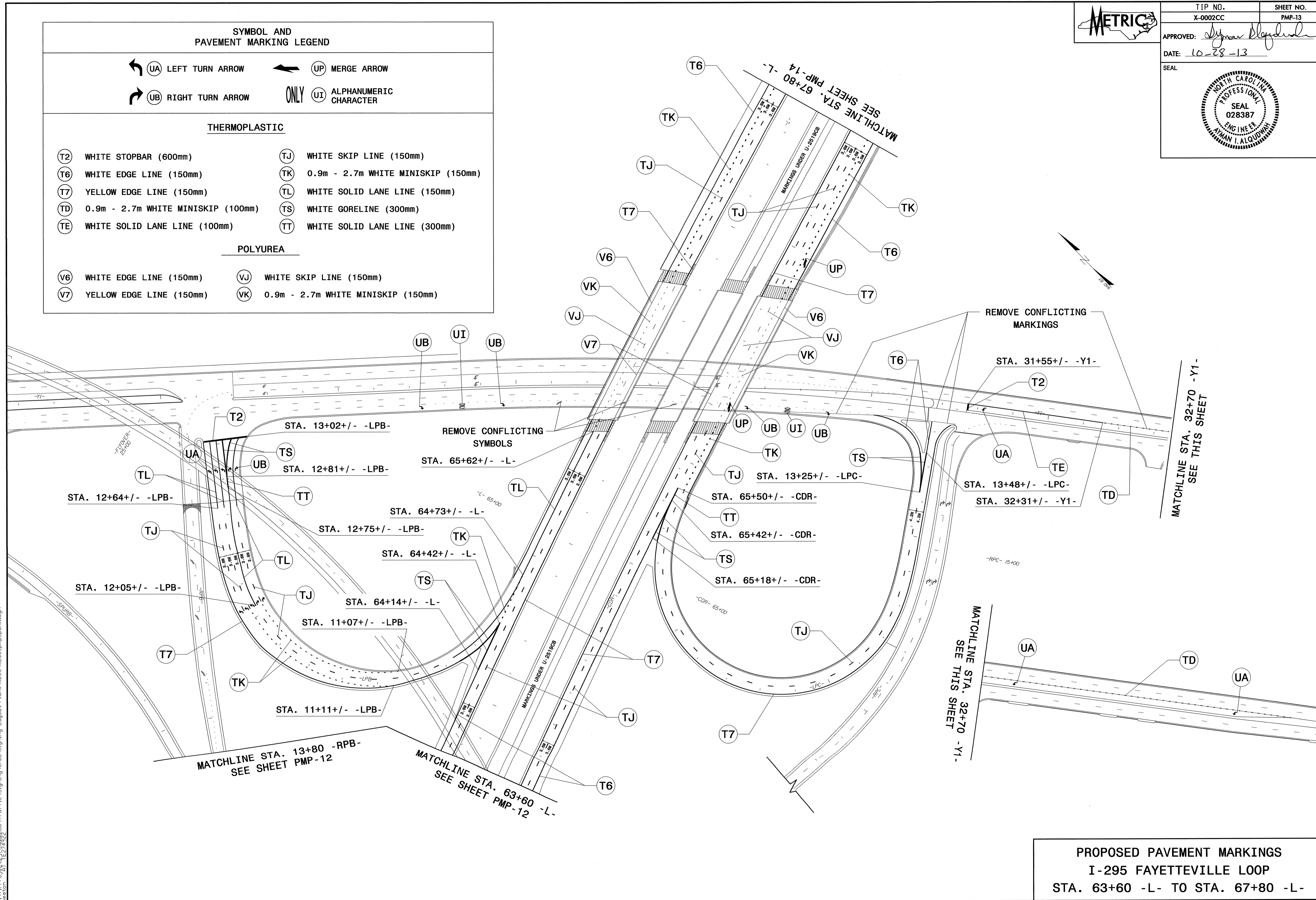

**PROPOSED PAVEMENT MARKINGS**  
 I-295 FAYETTEVILLE LOOP  
 STA. 63+60 -L- TO STA. 67+80 -L-

15-OCT-2013 16:03  
 P:\TIPProjects\130028B\Traffic\Signing\CADD\Signing Layout Plans\2cc\2cc.pmp-ph11.dgn  
 User: [unclear]





TIP NO. X-0002CC	SHEET NO. PMP-14
APPROVED: <i>[Signature]</i>	
DATE: 11-1-13	
SEAL	

SYMBOL AND PAVEMENT MARKING LEGEND	
	MERGE ARROW
THERMOPLASTIC	
	WHITE EDGE LINE (150mm)
	YELLOW EDGE LINE (150mm)
	WHITE SKIP LINE (150mm)
	0.9m - 2.7m WHITE MINISKIP (150mm)
	WHITE GORELINE (300mm)

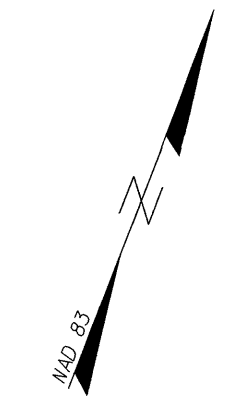

TUBULAR MARKERS (FIX.)  
18 M ON CENTERS TYP.  
TO REMAIN IN PLACE

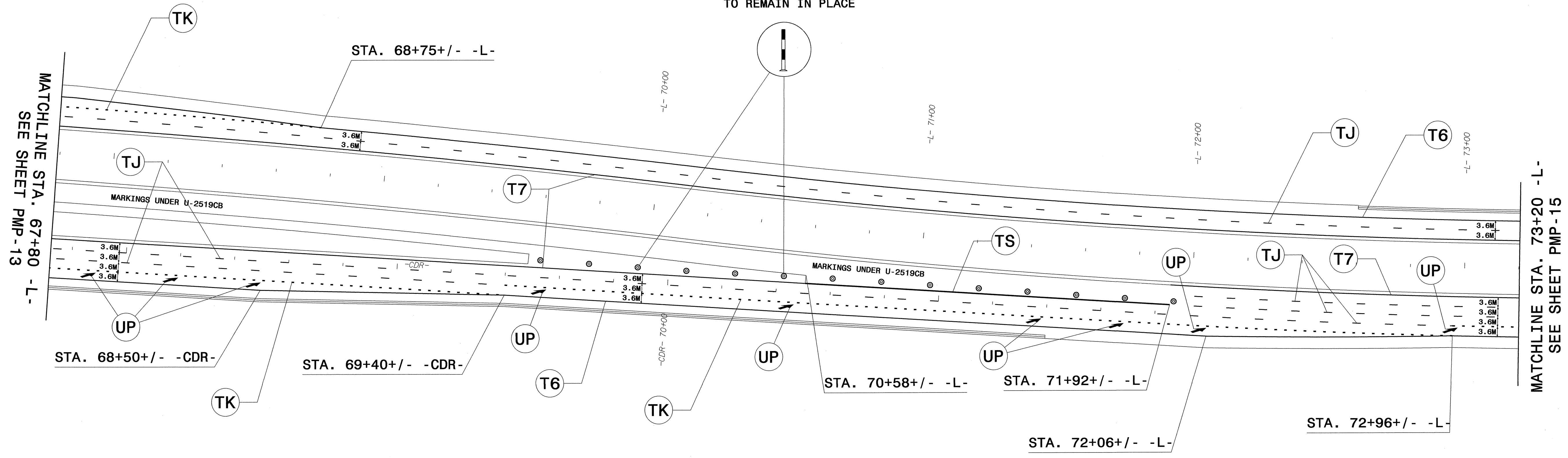

**PROPOSED PAVEMENT MARKINGS**  
I-295 FAYETTEVILLE LOOP  
STA. 67+80 -L- TO STA. 73+20 -L-

30-OCT-2013 15:31  
 P:\ASUP\Projects\130928B\Traffic\Signing\Layout\Plans\2cc\2cc.pmp.psh2.dgn  
 P:\ASUP\Projects\130928B\Traffic\Signing\Layout\Plans\2cc\2cc.pmp.psh2.dgn



TIP NO. X-0002CC	SHEET NO. PMP-15
APPROVED: <i>[Signature]</i>	
DATE: 10-28-13	

SEAL

SYMBOL AND PAVEMENT MARKING LEGEND			
← (UP) MERGE ARROW			
THERMOPLASTIC			
(T6) WHITE EDGE LINE (150mm)	(TJ) WHITE SKIP LINE (150mm)		
(T7) YELLOW EDGE LINE (150mm)	(TK) 0.9m - 2.7m WHITE MINISKIP (150mm)		
POLYUREA			
(V6) WHITE EDGE LINE (150mm)	(VJ) WHITE SKIP LINE (150mm)		
(V7) YELLOW EDGE LINE (150mm)			

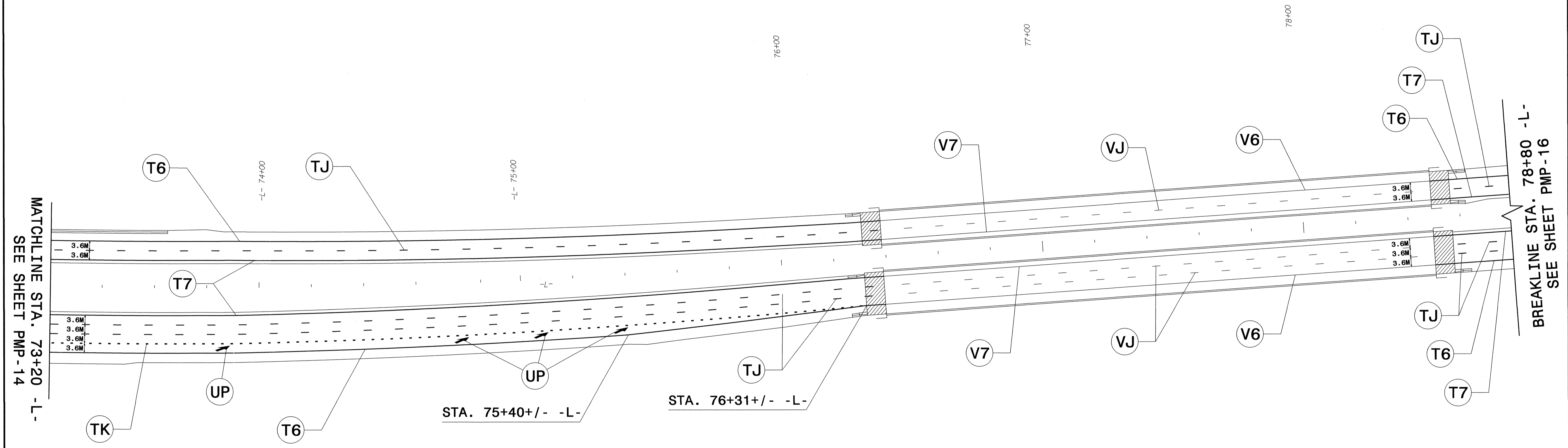
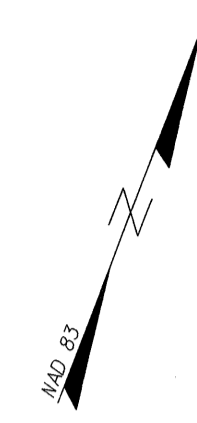

I:\Projects\2013\09\I-295\Drawings\Traffic\Signing\Layout\Plans\2cc\pmp-15.dgn  
 10/28/13 10:51 AM  
 N. ALQUODH

**PROPOSED PAVEMENT MARKINGS**  
**I-295 FAYETTEVILLE LOOP**  
**STA. 73+20 -L- TO STA. 78+80 -L-**



TIP NO. X-0002CC	SHEET NO. PMP-16
APPROVED: <i>[Signature]</i>	
DATE: 10-28-13	
SEAL	

SYMBOL AND PAVEMENT MARKING LEGEND			
(UP) MERGE ARROW			
THERMOPLASTIC			
(T6)	WHITE EDGE LINE (150mm)	(TJ)	WHITE SKIP LINE (150mm)
(T7)	YELLOW EDGE LINE (150mm)	(TK)	0.9m - 2.7m WHITE MINISKIP (150mm)

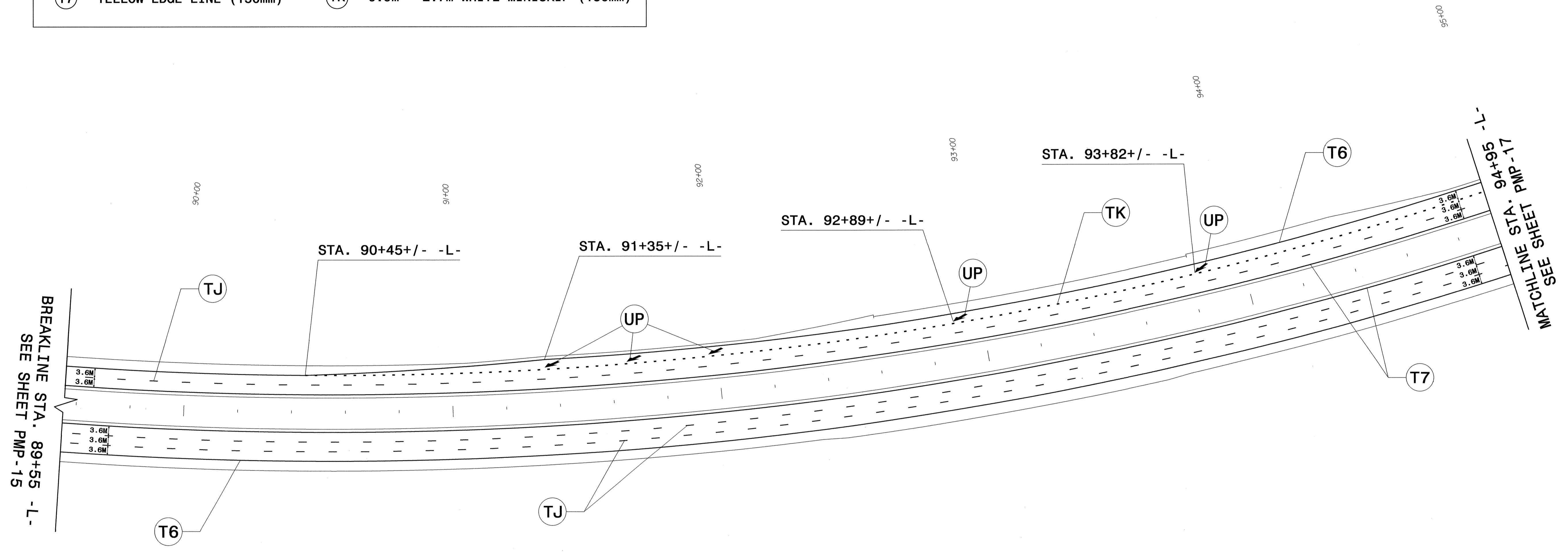
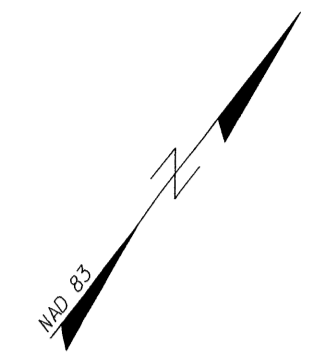

BREAKLINE STA. 89+55 -L-  
SEE SHEET PMP-15

MATCHLINE SHEET PMP-17  
STA. 94+95 -L-

**PROPOSED PAVEMENT MARKINGS**  
**I-295 FAYETTEVILLE LOOP**  
**STA. 89+55 -L- TO STA. 94+95 -L-**

P:\CCT\2013\_09\2\X-0002CC\Traffic\Signing\CADD\Signing Layout Plans\2cc\2cc.v2cc\2cc.pmp\_pah14.dgn  
 10/28/13 10:51 AM  
 N. I. Alquodhi





TIP NO. X-0002CC SHEET NO. PMP-17  
 APPROVED: *[Signature]*  
 DATE: 10-28-13

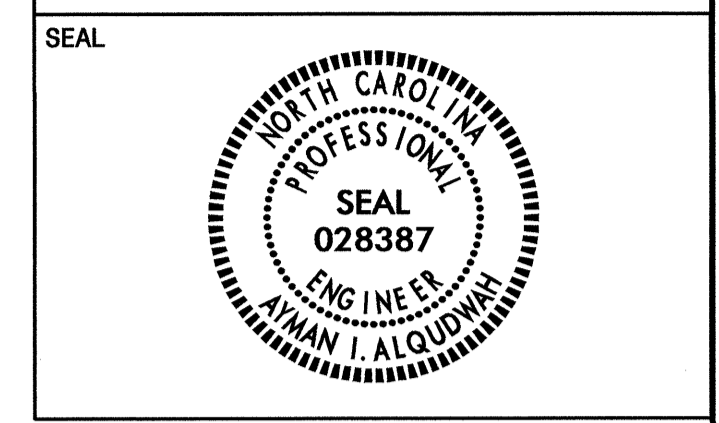

SYMBOL AND PAVEMENT MARKING LEGEND					
	UB	RIGHT TURN ARROW		UP	MERGE ARROW
ONLY		UI	ALPHANUMERIC CHARACTER		
THERMOPLASTIC					
T6	WHITE EDGE LINE (150mm)		TK	0.9m - 2.7m WHITE MINISKIP (150mm)	
T7	YELLOW EDGE LINE (150mm)		TS	WHITE GORELINE (300mm)	
TJ	WHITE SKIP LINE (150mm)		TT	WHITE SOLID LANE LINE (300mm)	

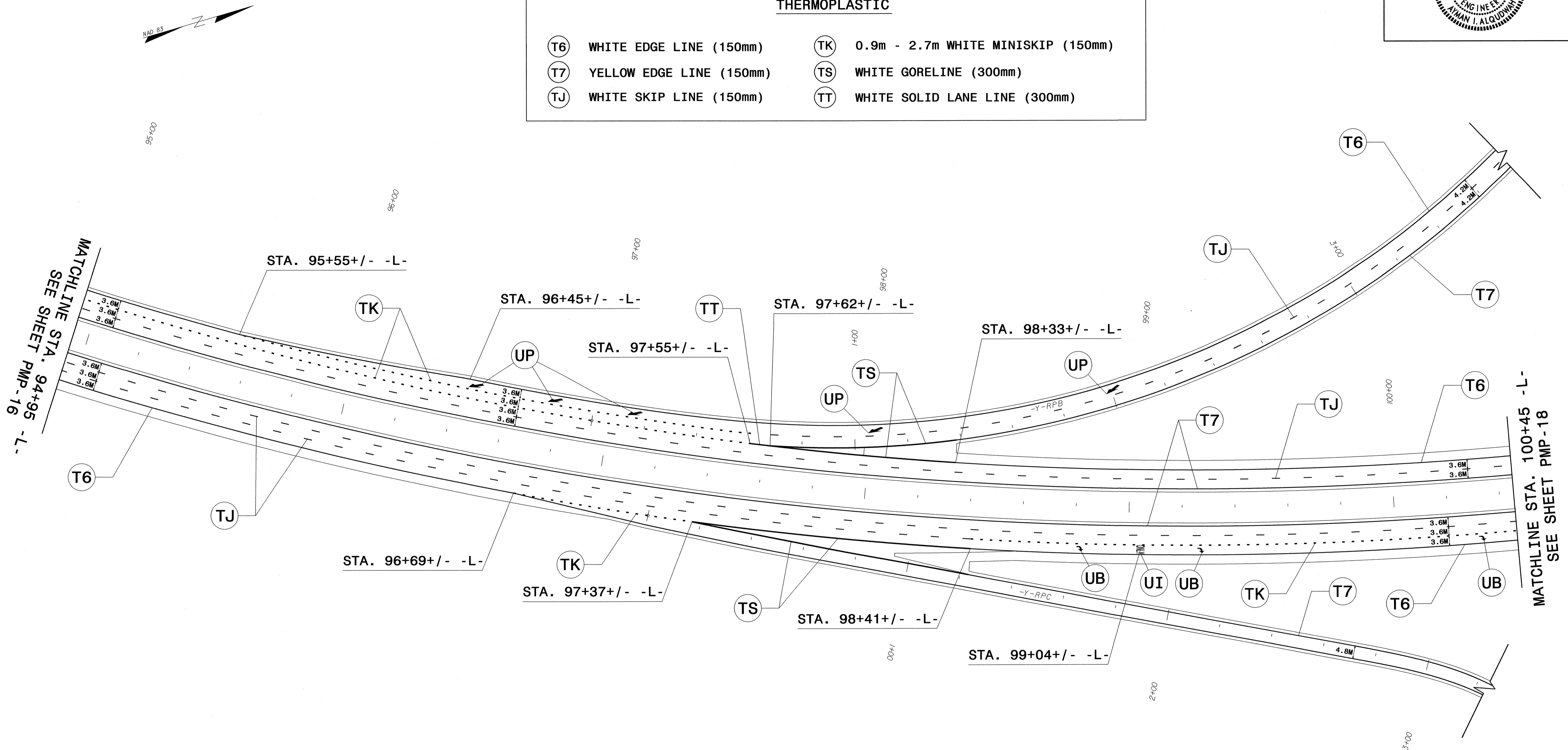

**PROPOSED PAVEMENT MARKINGS**  
 I-295 FAYETTEVILLE LOOP  
 STA. 94+95 -L- TO STA. 100+45 -L-

I:\CT\2013\09\28\20130928\Traffic\Signing\CADD\Signing\_Layout\_Plans\2ce\pmp.pah15.dgn  
 10/28/13 10:51:11 AM  
 mason



TIP NO. X-0002CC SHEET NO. PMP-18  
 APPROVED: *[Signature]*  
 DATE: 10-28-13

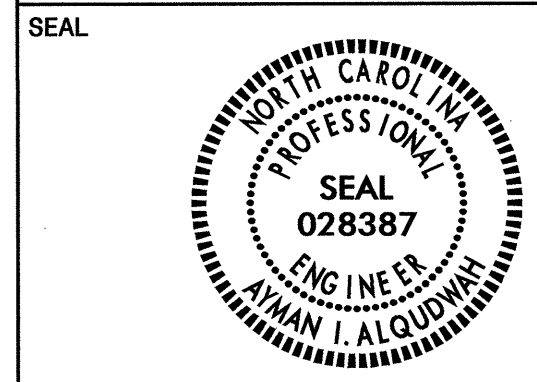

**SYMBOL AND PAVEMENT MARKING LEGEND**

- (UB) RIGHT TURN ARROW
- (UI) ALPHANUMERIC CHARACTER
- (UP) MERGE ARROW

**THERMOPLASTIC**

- (T2) WHITE STOPBAR (610mm)
- (T6) WHITE EDGE LINE (150mm)
- (T7) YELLOW EDGE LINE (150mm)
- (T8) 0.6m - 1.8m WHITE MINISKIP (100mm)
- (TJ) WHITE SKIP LINE (150mm)
- (TK) 0.9m - 2.7m WHITE MINISKIP (150mm)
- (TL) WHITE SOLID LANE LINE (150mm)
- (TS) WHITE GORELINE (300mm)
- (TT) WHITE SOLID LANE LINE (300mm)

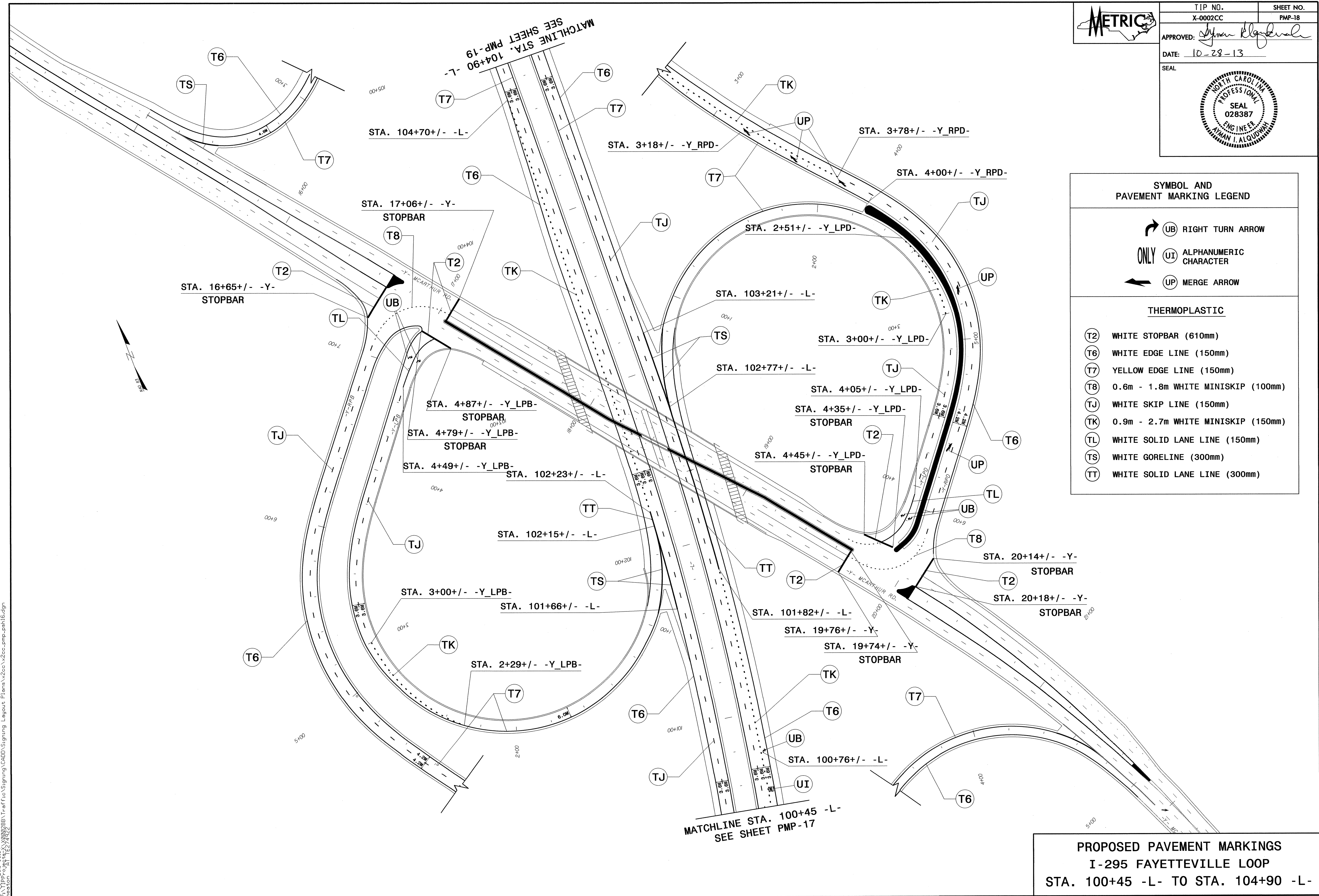

**PROPOSED PAVEMENT MARKINGS**  
**I-295 FAYETTEVILLE LOOP**  
**STA. 100+45 -L- TO STA. 104+90 -L-**

I:\Projects\2013\0915\X2002CC\Traffic\Signing\CADD\Signing\_Layout\_Plans\2cc.pmp\_pah16.dgn  
 10/28/13 10:54 AM  
 meator











TIP NO. X-0002CC	SHEET NO. PMP-22
APPROVED: <i>[Signature]</i>	
DATE: 10-28-13	
SEAL	

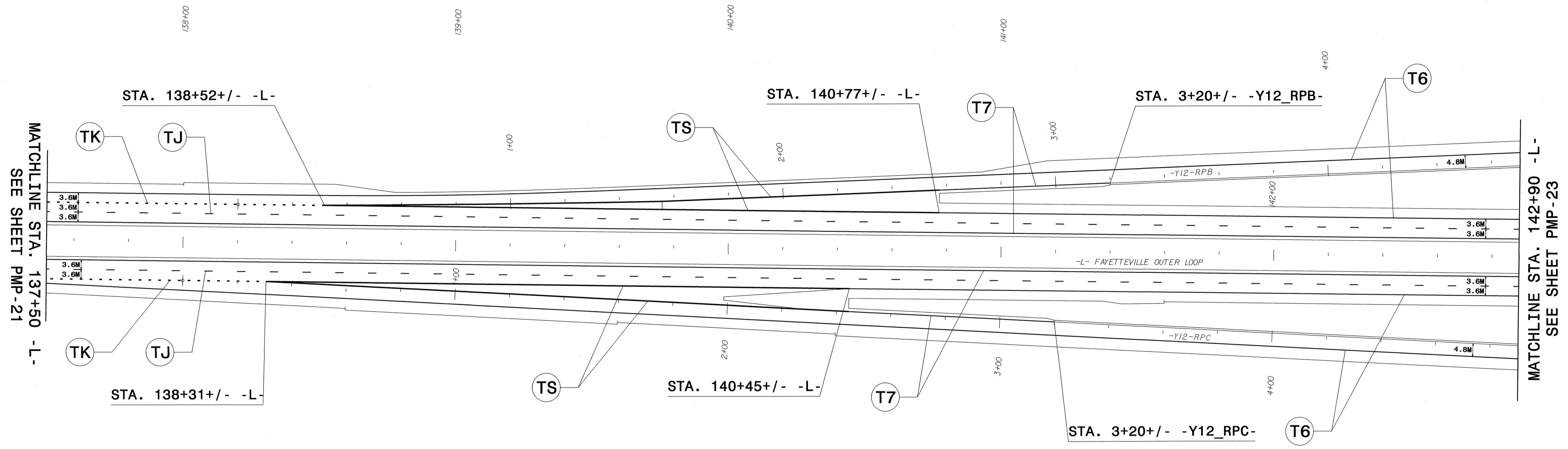
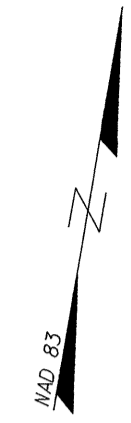

PAVEMENT MARKING LEGEND	
THERMOPLASTIC	
(T6) WHITE EDGE LINE (150mm)	(TK) 0.9m - 2.7m WHITE MINISKIP (150mm)
(T7) YELLOW EDGE LINE (150mm)	(TS) WHITE GORELINE (300mm)
(TJ) WHITE SKIP LINE (150mm)	

**PROPOSED PAVEMENT MARKINGS**  
**I-295 FAYETTEVILLE LOOP**  
**STA. 137+50 -L- TO STA. 142+90 -L-**

15-OCT-2013 10:23  
 P:\TIP\028387\028387\Traffic\Signing\C400\Signing\_Layout\Plans\2cc\2cc.v2cc.pmp-psh20.dgn  
 Reason: 51 12/2/13







TIP NO. X-002CC SHEET NO. PMP-24  
 APPROVED: *[Signature]*  
 DATE: 10-28-13

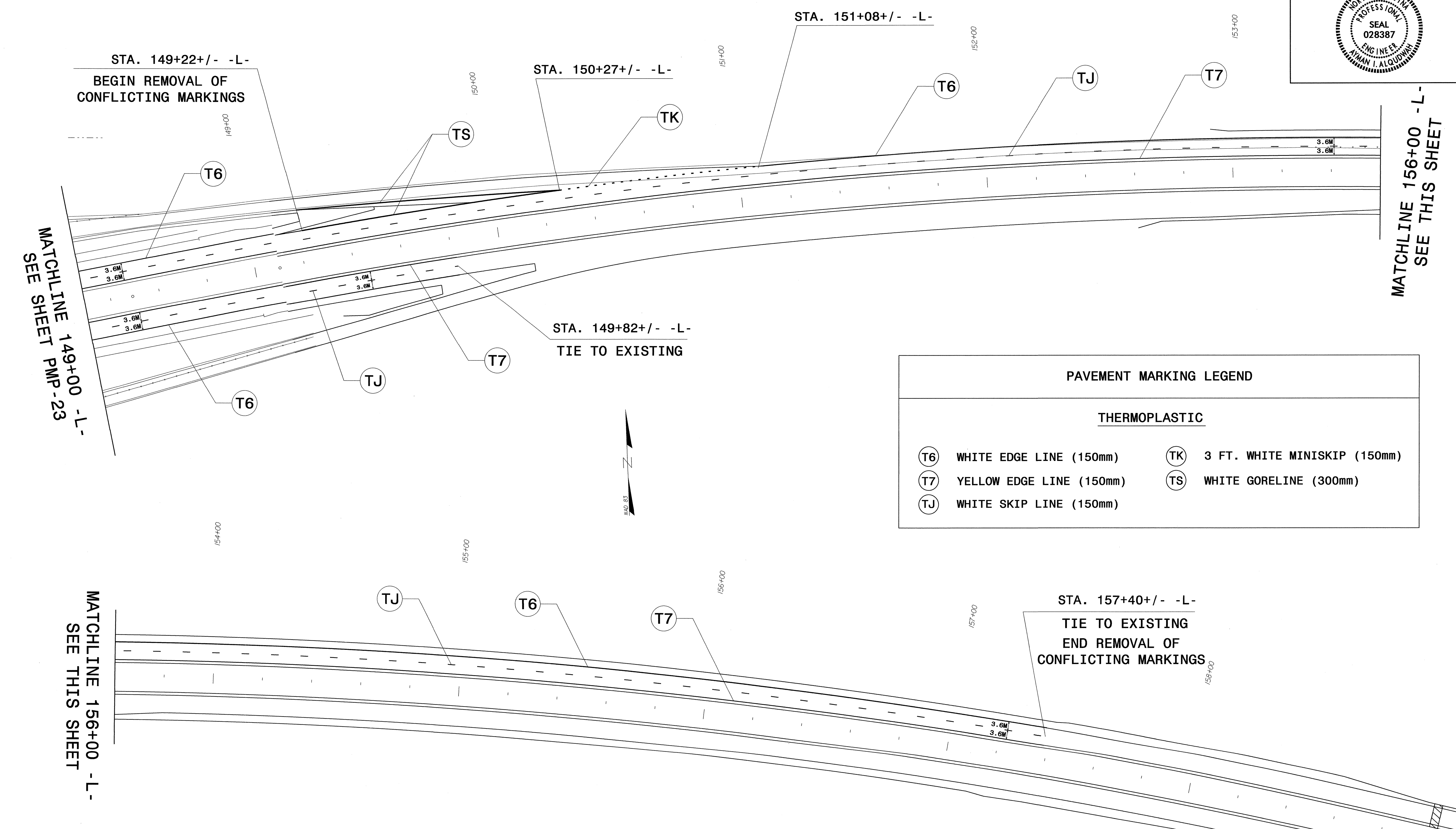
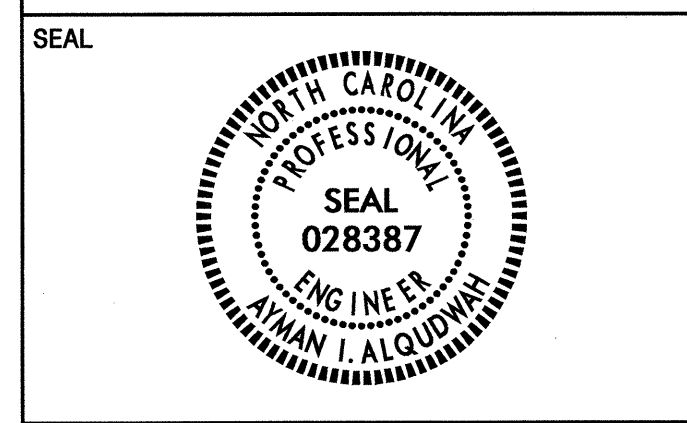

MATCHLINE 149+00 -L-  
SEE SHEET PMP-23

MATCHLINE 156+00 -L-  
SEE THIS SHEET

PAVEMENT MARKING LEGEND			
THERMOPLASTIC			
(T6)	WHITE EDGE LINE (150mm)	(TK)	3 FT. WHITE MINISKIP (150mm)
(T7)	YELLOW EDGE LINE (150mm)	(TS)	WHITE GORELINE (300mm)
(TJ)	WHITE SKIP LINE (150mm)		



MATCHLINE 156+00 -L-  
SEE THIS SHEET

STA. 157+40+/- -L-  
TIE TO EXISTING  
END REMOVAL OF  
CONFLICTING MARKINGS

PROPOSED PAVEMENT MARKINGS  
 I-295 FAYETTEVILLE LOOP  
 STA. 149+00 -L- TO STA. 156+00 -L-

I:\Projects\2013\107\X002CC\Signing\Layout\Plans\2cc.pmp.psh22.dgn  
 10/28/13 10:48:28 AM  
 Awan I. Alqumail