

STATE	STATE PROJECT REFERENCE NO.	SHEET NO.	TOTAL SHEETS
N.C.	R-2707AB	1	
STATE PROJ. NO.	F.A. PROJ. NO.	DESCRIPTION	
34497.1.2	NHF-0074(14)	PE	
34497.2.3	NHF-0074(76)	R/W, UTIL	
34497.3.FS4	NHF-0074(142)	CONST.	

STATE OF NORTH CAROLINA
DIVISION OF HIGHWAYS

CLEVELAND COUNTY

LOCATION: US 74 (SHELBY BYPASS) FROM EAST OF SR 1318
(KIMBRELL ROAD) TO EAST OF SR 1315
(PLATO LEE ROAD)

TYPE OF WORK: GRADING, PAVING, DRAINAGE, AND STRUCTURES

See Sheet 1-A For Index of Sheets

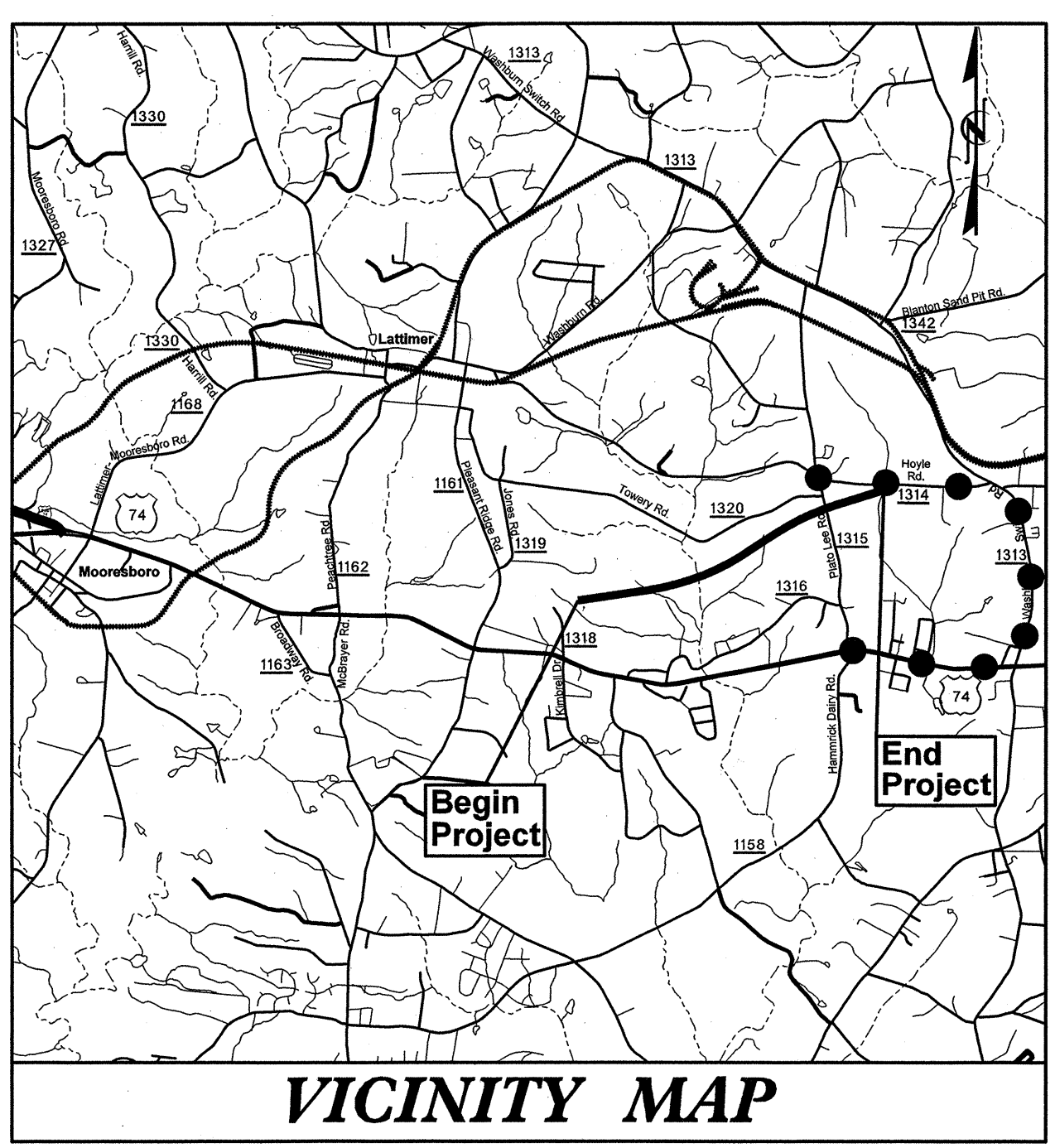

VICINITY MAP

●●●● OFF-SITE DETOUR

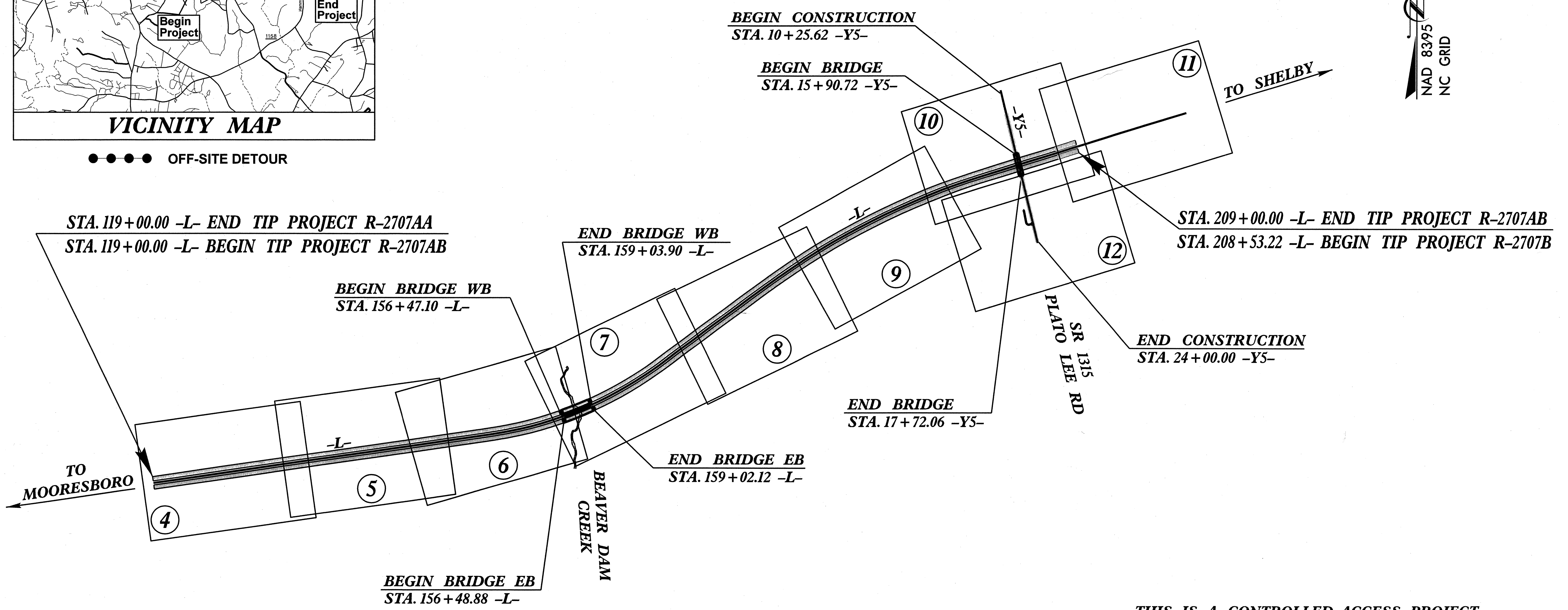

THIS IS A CONTROLLED-ACCESS PROJECT
WITH ACCESS BEING LIMITED TO INTERCHANGES

TIP R-2707AB

CONTRACT: C203027

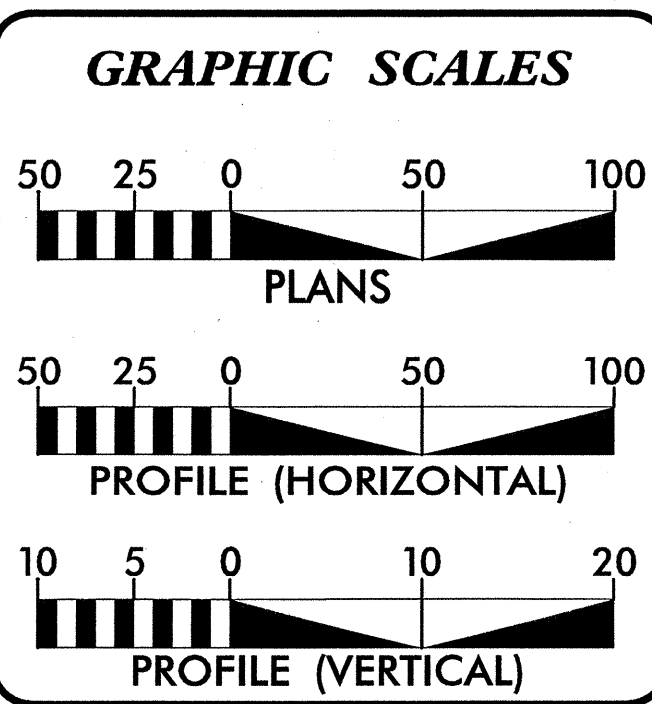

DESIGN DATA

ADT 2012 =	6,300
ADT 2035 =	16,400
DHV =	11 %
D =	55 %
T =	24 % *
V =	70 MPH
* TTST 18% DUAL 6%	
FUNC CLASS =	FREWAY
STATEWIDE TIER DESIGN	

PROJECT LENGTH

LENGTH OF ROADWAY TIP PROJECT R-2707AB =	1.656 miles
LENGTH OF STRUCTURE TIP PROJECT R-2707AB =	0.049 miles
TOTAL LENGTH TIP PROJECT R-2707AB =	1.705 miles

NOTE: WESTBOUND LANE USED TO DETERMINE LENGTH OF ROADWAY AND STRUCTURES

Prepared In The Office of:

ARCADIS
G & M of North Carolina, Inc.
www.ARCADIS-US.COM
80 Corporate Center Drive, Suite 300
Raleigh, NC 27607-5073
Tel: 919/854-1262 Fax: 919/854-5448 NC License No. C-869

GREENHORNE & O'MARA
CONSULTING ENGINEERS
5565 CENTERVIEW DRIVE, SUITE 107
RALEIGH, NC 27606
919 851-1919 FAX 919 851-8393
LICENSE # P-6148

for the North Carolina Department of Transportation

2012 STANDARD SPECIFICATIONS	ARCADIS CONTACT
RIGHT OF WAY DATE: JUNE 30, 2010	STEVE SMALLWOOD, P.E. PROJECT ENGINEER
LETTING DATE: MAY 20, 2014	NCDOT CONTACT: BRENDA MOORE, P.E.

HYDRAULICS ENGINEER

STEVEN W. BOWEN
ENGINEER
SEAL 12786
2/24/14
P.E.

ROADWAY DESIGN ENGINEER

STEVE SMALLWOOD
ENGINEER
SEAL 12786
2/24/14
P.E.

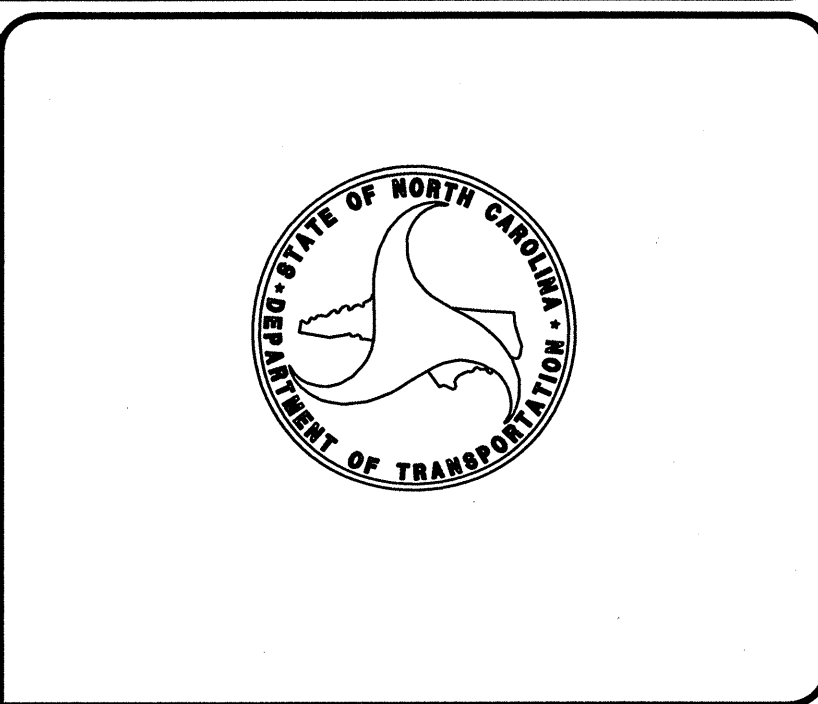

ARCADIS GSM
03/08/2014
Time: 4:15PM
Filename: \$FILE\$

04/16/11

2012 ROADWAY ENGLISH STANDARD DRAWINGS

EFF. 01-17-12

The following Roadway Standards as appear in "Roadway Standard Drawings" Highway Design Branch - N. C. Department of Transportation - Raleigh, N. C., Dated January, 2012 are applicable to this project and by reference hereby are considered a part of these plans:

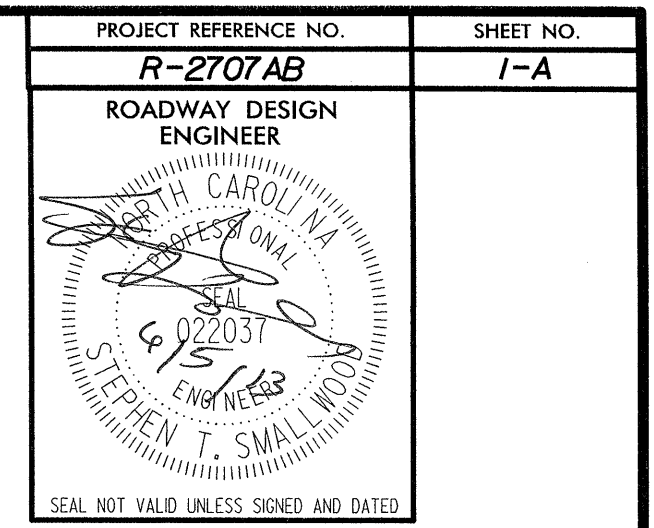

INDEX OF SHEETS	
SHEET NUMBER	SHEET
1	TITLE SHEET
1-A	INDEX OF SHEETS, GENERAL NOTES, AND LIST OF STANDARD DRAWINGS
1-B	CONVENTIONAL SYMBOLS
1-C THRU 1-F	SURVEY CONTROL SHEETS
1-G	CENTERLINE COORDINATE LIST
2	PAVEMENT SCHEDULE, WEDGING DETAIL, AND TYPICAL SECTIONS
2-A	DETAIL OF TEMPORARY STEEL COVER FOR DRAINAGE STRUCTURES
2-B	DETAIL OF JUNCTION BOX UNDER 25' FILL
3-A THRU 3-C	SUMMARY OF DRAINAGE QUANTITIES
3-D	SUMMARY OF GUARDRAIL
3-E	SUMMARY OF PAVEMENT REMOVAL, WOVEN WIRE, AND SHOULDER BERM GUTTER
3-F	EARTHWORK SUMMARY
3-G	WAITING PERIOD SUMMARY
3-H	PARCEL INDEX SHEET
4 THRU 12	PLAN SHEETS
13 THRU 17	PROFILE SHEETS
TMP-1 THRU TMP-3	TRAFFIC MANAGEMENT PLANS
SP-1	SPECIAL SIGN DESIGN
PMP-1	PAVEMENT MARKING PLANS
EC-1 THRU EC-21	EROSION CONTROL PLANS
UC-1 THRU UC-10	UTILITY CONSTRUCTION PLANS
UO-1 THRU UO-5	UTILITIES BY OTHERS PLANS
X-INDEX	CROSS SECTION INDEX
X-1A	CROSS SECTION SUMMARY SHEETS
X-1 THRU X-52	CROSS SECTIONS
S-1 THRU S-104	STRUCTURE PLANS

STD.NO.	TITLE
DIVISION 2 - EARTHWORK	
200.03	Method of Clearing - Method III
225.01	Guide for Grading Subgrade - Interstate and Freeway
225.02	Guide for Grading Subgrade - Secondary and Local
225.04	Method of Obtaining Superelevation - Two Lane Pavement
225.05	Method of Obtaining Superelevation - Divided Highways
240.01	Guide for Berm Ditch Construction
DIVISION 3 - PIPE CULVERTS	
300.01	Method of Pipe Installation
DIVISION 4 - MAJOR STRUCTURES	
422.10	Reinforced Bridge Approach Fills
DIVISION 5 - SUBGRADE, BASES AND SHOULDERS	
560.01	Method of Shoulder Construction - High Side of Superelevated Curve - Method I
DIVISION 8 - INCIDENTALS	
815.03	Pipe Underdrain and Blind Drain
838.01	Concrete Endwall for Single and Double Pipe Culverts - 15" thru 48" Pipe 90 Skew
838.11	Brick Endwall for Single and Double Pipe Culverts - 15" thru 48" Pipe 90 Skew
838.80	Precast Endwalls - 12" thru 72" Pipe 90 Skew
840.00	Concrete Base Pad for Drainage Structures
840.17	Concrete Grated Drop Inlet Type 'A' - 12" thru 72" Pipe
840.18	Concrete Grated Drop Inlet Type 'B' - 12" thru 36" Pipe
840.20	Frames and Wide Slot Flat Grates
840.22	Frames and Wide Slot Sag Grates
840.25	Anchorage for Frames - Brick or Concrete
840.26	Brick Grated Drop Inlet Type 'A' - 12" thru 72" Pipe
840.27	Brick Grated Drop Inlet Type 'B' - 12" thru 36" Pipe
840.31	Concrete Junction Box - 12" thru 66" Pipe
840.32	Brick Junction Box - 12" thru 66" Pipe
840.33	Angled Vane Grates and Frames
840.45	Precast Drainage Structure
840.54	Manhole Frame and Cover
840.66	Drainage Structure Steps
840.72	Pipe Collar
846.04	Drop Inlet Installation in Shoulder Berm Gutter
850.10	Guide for Berm Drainage Outlet - 15" and 18" Pipe
850.11	Guide for Berm Drainage Outlet - 24" and 30" Pipe
862.01	Guardrail Placement
862.02	Guardrail Installation
862.03	Structure Anchor Units
862.04	Anchoring End of Guardrail - B-77 and B-83 Anchor Units
866.02	Woven Wire Fence - with Wood Post
876.01	Rip Rap in Channels
876.02	Guide for Rip Rap at Pipe Outlets
876.04	Drainage Ditches with Class 'B' Rip Rap

GENERAL NOTES: 2012 SPECIFICATIONS

EFFECTIVE: 01-17-12
REVISED: 11-01-11

GRADING AND SURFACING OR RESURFACING AND WIDENING:

THE GRADE LINES SHOWN DENOTE THE FINISHED ELEVATION OF THE PROPOSED SURFACING AT GRADE POINTS SHOWN ON THE TYPICAL SECTIONS. WHERE NO GRADE LINES ARE SHOWN, THE PROFILES SHOWN DENOTE THE TOP ELEVATION OF THE EXISTING PAVEMENT ALONG THE CENTER LINE OF SURVEY ON WHICH THE PROPOSED RESURFACING WILL BE PLACED. GRADE LINES MAY BE ADJUSTED BY THE ENGINEER IN ORDER TO SECURE A PROPER TIE-IN.

CLEARING:

CLEARING ON THIS PROJECT SHALL BE PERFORMED TO THE LIMITS ESTABLISHED BY METHOD III.

SUPERELEVATION:

ALL CURVES ON THIS PROJECT SHALL BE SUPERELEVATED IN ACCORDANCE WITH STD. NO. 225.04 AND 225.05. USING THE RATE OF SUPERELEVATION AND RUNOFF SHOWN ON THE PLANS. SUPERELEVATION IS TO BE REVOLVED ABOUT THE GRADE POINTS SHOWN ON THE TYPICAL SECTIONS.

SHOULDER CONSTRUCTION:

ASPHALT, EARTH, AND CONCRETE SHOULDER CONSTRUCTION ON THE HIGH SIDE OF SUPERELEVATED CURVES SHALL BE IN ACCORDANCE WITH STD. NO. 560.01 & 560.02.

SIDE ROADS:

THE CONTRACTOR WILL BE REQUIRED TO DO ALL NECESSARY WORK TO PROVIDE SUITABLE CONNECTIONS WITH ALL ROADS, STREETS, AND DRIVES ENTERING THIS PROJECT. THIS WORK WILL BE PAID FOR AT THE CONTRACT UNIT PRICE FOR THE PARTICULAR ITEMS INVOLVED.

BERM DITCHES:

BERM DITCHES SHALL BE CONSTRUCTED IN ACCORDANCE WITH STD. NO. 240.01 AT LOCATIONS SHOWN ON THE PLANS OR AS DIRECTED BY THE ENGINEER.

UNDERDRAINS:

UNDERDRAINS SHALL BE CONSTRUCTED IN ACCORDANCE WITH STD. NO. 815.03 AT LOCATIONS DIRECTED BY THE ENGINEER.

GUARDRAIL:

THE GUARDRAIL LOCATIONS SHOWN ON THE PLANS MAY BE ADJUSTED DURING CONSTRUCTION AS DIRECTED BY THE ENGINEER. THE CONTRACTOR SHOULD CONSULT WITH THE ENGINEER PRIOR TO ORDERING GUARDRAIL MATERIAL.

TEMPORARY SHORING:

SHORING REQUIRED FOR THE MAINTENANCE OF TRAFFIC WILL BE PAID FOR AS "EXTRA WORK" IN ACCORDANCE WITH SECTION 104-7.

END BENTS:

THE ENGINEER SHALL CHECK THE STRUCTURE END BENT PLANS, DETAILS, AND CROSS-SECTION PRIOR TO SETTING OF THE SLOPE STAKES FOR THE EMBANKMENT OR EXCAVATION APPROACHING A BRIDGE.

UTILITIES:

UTILITY OWNERS ON THIS PROJECT ARE AT&T, CITY OF SHELBY(GAS), CLEVELAND COUNTY SANITARY DISTRICT(WATER) UTILITIES, CITY OF LATTIMORE PUBLIC, DUKE POWER, TIME WARNER CABLE TV.

ANY RELOCATION OF EXISTING UTILITIES WILL BE ACCOMPLISHED BY OTHERS, EXCEPT AS SHOWN ON THE PLANS.

RIGHT-OF-WAY MARKERS:

ALL RIGHT-OF-WAY MARKERS ON THIS PROJECT SHALL BE PLACED BY OTHERS.















Note: Not to Scale

*S.U.E. = Subsurface Utility Engineering











STATE OF NORTH CAROLINA
DIVISION OF HIGHWAYS

CONVENTIONAL PLAN SHEET SYMBOLS











BOUNDARIES AND PROPERTY:

State Line	-----
County Line	-----
Township Line	-----
City Line	-----
Reservation Line	-----
Property Line	-----
Existing Iron Pin	----- 
Property Corner	----- 
Property Monument	----- 
Parcel/Sequence Number	----- 
Existing Fence Line	----- 
Proposed Woven Wire Fence	----- 
Proposed Chain Link Fence	----- 
Proposed Barbed Wire Fence	----- 
Existing Wetland Boundary	----- 
Proposed Wetland Boundary	----- 
Existing Endangered Animal Boundary	----- 
Existing Endangered Plant Boundary	----- 
Known Soil Contamination: Area or Site	----- 
Potential Soil Contamination: Area or Site	----- 





BUILDINGS AND OTHER CULTURE:

Gas Pump Vent or U/G Tank Cap	----- 
Sign	----- 
Well	----- 
Small Mine	----- 
Foundation	----- 
Area Outline	----- 
Cemetery	----- 
Building	----- 
School	----- 
Church	----- 
Dam	----- 

















HYDROLOGY:

Stream or Body of Water	-----
Hydro, Pool or Reservoir	----- 
Jurisdictional Stream	----- 
Buffer Zone 1	----- 
Buffer Zone 2	----- 
Flow Arrow	----- 
Disappearing Stream	----- 
Spring	----- 
Wetland	----- 
Proposed Lateral, Tail, Head Ditch	----- 
False Sump	----- 









RAILROADS:

Standard Gauge	----- 
RR Signal Milepost	----- 
Switch	----- 
RR Abandoned	----- 
RR Dismantled	----- 





RIGHT OF WAY:



Baseline Control Point	----- 
Existing Right of Way Marker	----- 
Existing Right of Way Line	----- 
Proposed Right of Way Line	----- 
Proposed Right of Way Line with Iron Pin and Cap Marker	----- 
Proposed Right of Way Line with Concrete or Granite R/W Marker	----- 
Existing Control of Access	----- 
Proposed Control of Access Line with Concrete C/A Marker	----- 
Existing Easement Line	----- 
Proposed Temporary Construction Easement	----- 
Proposed Temporary Drainage Easement	----- 
Proposed Permanent Drainage Easement	----- 
Proposed Permanent Drainage / Utility Easement	----- 
Proposed Permanent Utility Easement	----- 
Proposed Temporary Utility Easement	----- 
Proposed Aerial Utility Easement	----- 
Proposed Permanent Easement with Iron Pin and Cap Marker	----- 

ROADS AND RELATED FEATURES:









Existing Edge of Pavement	-----
Existing Curb	-----
Proposed Slope Stakes Cut	----- 
Proposed Slope Stakes Fill	----- 
Proposed Curb Ramp	----- 
Existing Metal Guardrail	----- 
Proposed Guardrail	----- 
Existing Cable Guiderail	----- 
Proposed Cable Guiderail	----- 
Equality Symbol	----- 
Pavement Removal	----- 

VEGETATION:











Single Tree	----- 
Single Shrub	----- 
Hedge	----- 
Woods Line	----- 

Orchard	----- 
Vineyard	----- 













EXISTING STRUCTURES:

MAJOR:	
Bridge, Tunnel or Box Culvert	----- 
Bridge Wing Wall, Head Wall and End Wall	----- 
MINOR:	
Head and End Wall	----- 
Pipe Culvert	----- 
Footbridge	----- 
Drainage Box: Catch Basin, DI or JB	----- 
Paved Ditch Gutter	----- 
Storm Sewer Manhole	----- 
Storm Sewer	----- 







UTILITIES:

POWER:	
Existing Power Pole	----- 
Proposed Power Pole	----- 
Existing Joint Use Pole	----- 
Proposed Joint Use Pole	----- 
Power Manhole	----- 
Power Line Tower	----- 
Power Transformer	----- 
U/G Power Cable Hand Hole	----- 
H-Frame Pole	----- 
Recorded U/G Power Line	----- 
Designated U/G Power Line (S.U.E.*)	----- 









TELEPHONE:

Existing Telephone Pole	----- 
Proposed Telephone Pole	----- 
Telephone Manhole	----- 
Telephone Booth	----- 
Telephone Pedestal	----- 
Telephone Cell Tower	----- 
U/G Telephone Cable Hand Hole	----- 
Recorded U/G Telephone Cable	----- 
Designated U/G Telephone Cable (S.U.E.*)	----- 
Recorded U/G Telephone Conduit	----- 
Designated U/G Telephone Conduit (S.U.E.*)	----- 
Recorded U/G Fiber Optics Cable	----- 
Designated U/G Fiber Optics Cable (S.U.E.*)	----- 





WATER:

Water Manhole	----- 
Water Meter	----- 
Water Valve	----- 
Water Hydrant	----- 
Recorded U/G Water Line	----- 
Designated U/G Water Line (S.U.E.*)	----- 
Above Ground Water Line	----- 







TV:

TV Satellite Dish	----- 
TV Pedestal	----- 
TV Tower	----- 
U/G TV Cable Hand Hole	----- 
Recorded U/G TV Cable	----- 
Designated U/G TV Cable (S.U.E.*)	----- 
Recorded U/G Fiber Optic Cable	----- 
Designated U/G Fiber Optic Cable (S.U.E.*)	----- 













GAS:

Gas Valve	----- 
Gas Meter	----- 
Recorded U/G Gas Line	----- 
Designated U/G Gas Line (S.U.E.*)	----- 
Above Ground Gas Line	----- 

SANITARY SEWER:

Sanitary Sewer Manhole	----- 
Sanitary Sewer Cleanout	----- 
U/G Sanitary Sewer Line	----- 
Above Ground Sanitary Sewer	----- 
Recorded SS Forced Main Line	----- 
Designated SS Forced Main Line (S.U.E.*)	----- 

MISCELLANEOUS:

Utility Pole	----- 
Utility Pole with Base	----- 
Utility Located Object	----- 
Utility Traffic Signal Box	----- 
Utility Unknown U/G Line	----- 
U/G Tank; Water, Gas, Oil	----- 
Underground Storage Tank, Approx. Loc.	----- 
A/G Tank; Water, Gas, Oil	----- 
Geoenvironmental Boring	----- 
U/G Test Hole (S.U.E.*)	----- 
Abandoned According to Utility Records	----- 
End of Information	----- 

SURVEY CONTROL SHEET

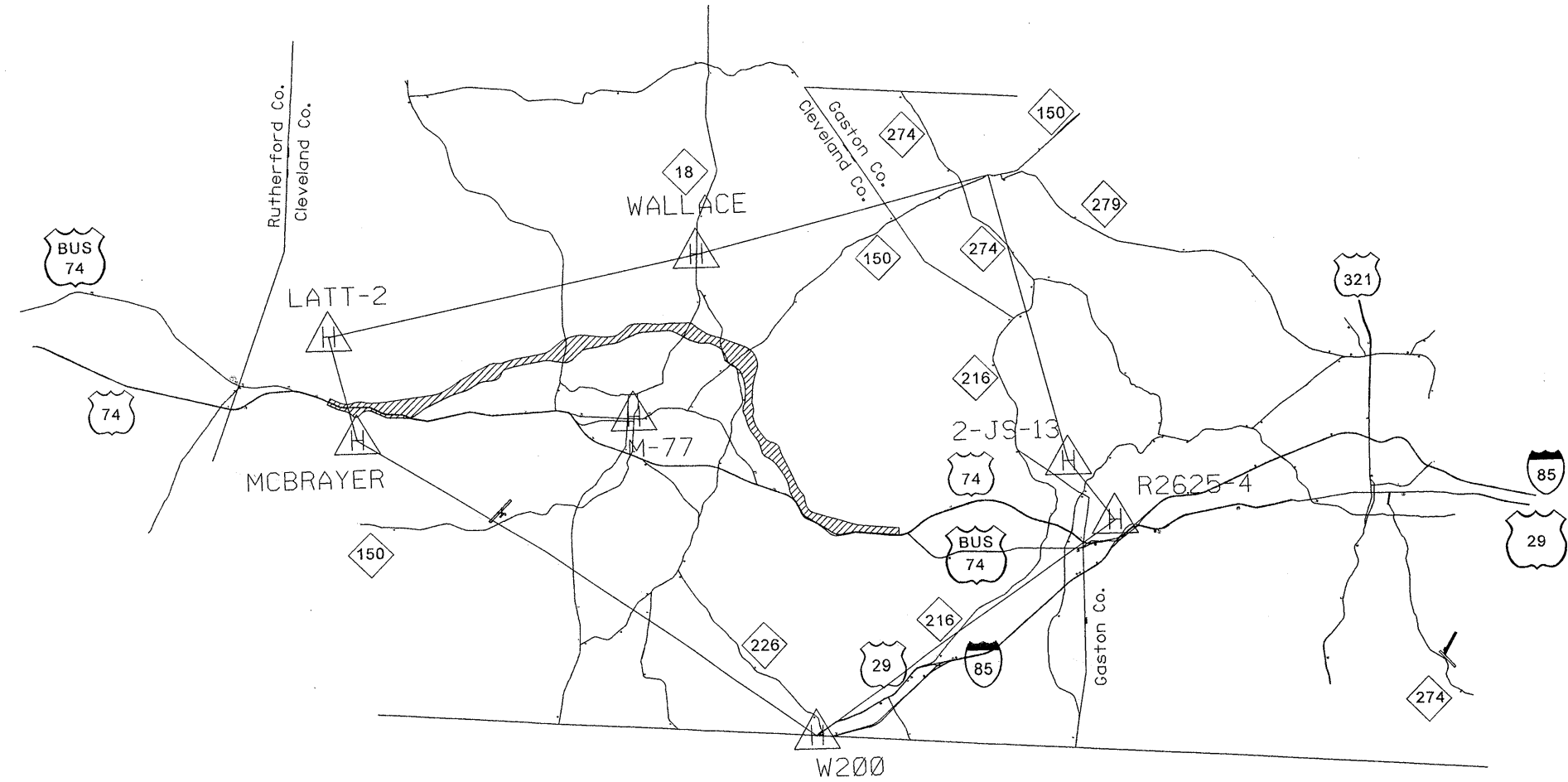

GPS NETWORK
NOT TO SCALE

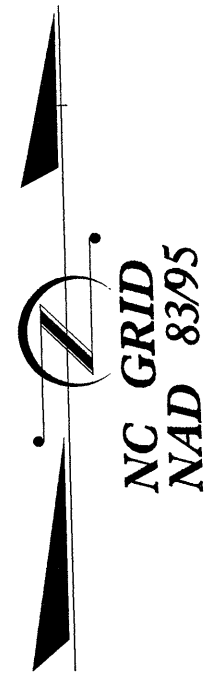

NOTES

1. THE SITE CALIBRATION SHOWN IS BASED UPON A NETWORK TIED TO THE HARN (HIGH ACCURACY REFERENCE NETWORK) NAD 83/95 ADJUSTMENT. THIS CALIBRATION WILL ALLOW THE END USER TO WORK WITHIN THE SAME COORDINATE SYSTEM WHEN USING RTK (REAL TIME KINEMATIC) GPS AND A LOCAL BASE STATION. IF ANOTHER SYSTEM SUCH AS VRS (VIRTUAL REFERENCE STATION) IS USED, ADDITIONAL FIELD TIES MAYBE NEEDED TO REDUCE POSSIBLE ERRORS, OR BIASES.
2. THE CONTROL DATA FOR THIS PROJECT CAN BE FOUND ELECTRONICALLY BY SELECTING PROJECT CONTROL DATA AT [HTTP://WWW.NCDOT.ORG/DOH/PRECONSTRUCT/HIGHWAY/LOCATION/PROJECT/](http://www.ncdot.org/DOH/PRECONSTRUCT/HIGHWAY/LOCATION/PROJECT/) THE FILES TO BE FOUND ARE AS FOLLOWS:
R2707A_LS_GPSCALIB_100701.PDF
R2707A_LS_WGS84_100701.TXT
R2707A_LS_LOCAL_100701.TXT
R2707A_LS_CONTROL_100701.TXT
THE WGS84 AND LOCAL FILES ARE COMMA DELIMITED AND CAN BE USED TO REPRODUCE THE SITE CALIBRATION FOR THE END USER'S GPS EQUIPMENT. IF FURTHER INFORMATION IS NEEDED, PLEASE CONTACT THE LOCATION AND SURVEYS UNIT.

-L- STA 119+00.00 END STATE PROJECT 34497.1.2 R2707AA
-L- STA 119+00.00 BEG. STATE PROJECT 34497.1.2 R2707AB
LOCALIZED PROJECT COORDINATES
N = 573,936.1353
E = 1,211,057.3639

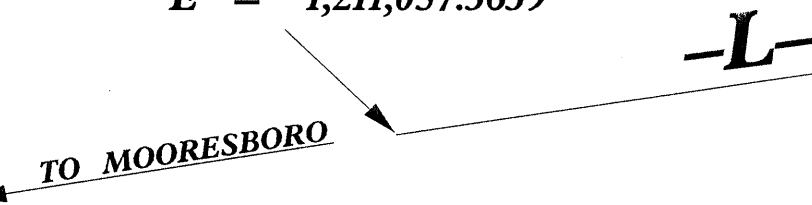

-L- STA 215+46.78 END STATE PROJECT 34497.1.2 R2707AB
LOCALIZED PROJECT COORDINATES
N = 577,151.0210 E = 1,219,982.0491
-L- STA 215+00.00 BEG. STATE PROJECT 34497.1.2 R2707B
LOCALIZED PROJECT COORDINATES
N = 577,151.0210 E = 1,219,982.0488

SR 135 PLATO LEE RD.

SR 135 PLATO LEE RD.

TO SHELBY

NCDOT GPS STATION R2707-6
LOCALIZED PROJECT COORDINATES
N = 578041.4940
E = 1223321.3870

NCDOT GPS STATION R2707-7
LOCALIZED PROJECT COORDINATES
N = 579006.8290
E = 1233137.4580

NCDOT GPS STATION R2707-5
LOCALIZED PROJECT COORDINATES
N = 577485.5880
E = 1224323.7950

NCDOT GPS STATION R2707-4
LOCALIZED PROJECT COORDINATES
N = 576194.7690
E = 1219011.5400

NCDOT GPS STATION R2707-3
LOCALIZED PROJECT COORDINATES
N = 575077.6710
E = 1219235.6660

DATUM DESCRIPTION

THE LOCALIZED COORDINATE SYSTEM DEVELOPED FOR THIS PROJECT IS BASED ON THE STATE PLANE COORDINATES ESTABLISHED BY NCGS FOR MONUMENT "M 77"
WITH NAD 83/95 STATE PLANE GRID COORDINATES OF
NORTHING: 573127.5221(fft) EASTING: 124297.658(fft)
ELEVATION: 852.279'(fft)
THE AVERAGE COMBINED GRID FACTOR USED ON THIS PROJECT (GROUND TO GRID) IS: 0.99984410
THE N.C. LAMBERT GRID BEARING AND LOCALIZED HORIZONTAL GROUND DISTANCE FROM "M 77" TO -L- L STATION 5+03.30 IS
N 75 36 14 W 3868.1352'
ALL LINEAR DIMENSIONS ARE LOCALIZED HORIZONTAL DISTANCES
VERTICAL DATUM USED IS NAVD 88

⊙ INDICATES GEODETIC CONTROL MONUMENTS USED OR SET FOR HORIZONTAL PROJECT CONTROL BY THE NCDOT LOCATION AND SURVEYS UNIT.
PROJECT CONTROL ESTABLISHED UTILIZING GLOBAL POSITIONING SYSTEM NETWORK ESTABLISHED FROM EXISTING HARN MONUMENTATION.
SEE GPS CALIBRATION SHEET FOR HORIZONTAL AND VERTICAL COORDINATE VALUES

NOTE: DRAWING NOT TO SCALE

5/23/13

STATE OF NORTH CAROLINA
DIVISION OF HIGHWAYS

CENTERLINE COORDINATE LIST

Point #	Chain	Station	Northing (Y)	Easting (X)
1	L	119+00.00	573936.1353	1211057.3639
2	L	119+50.00	573943.3151	1211106.8458
3	L	120+00.00	573950.4948	1211156.3276
4	L	120+50.00	573957.6746	1211205.8094
5	L	121+00.00	573964.8544	1211255.2912
6	L	121+50.00	573972.0341	1211304.7731
7	L	122+00.00	573979.2139	1211354.2549
8	L	122+50.00	573986.3936	1211403.7367
9	L	123+00.00	573993.5734	1211453.2185
10	L	123+50.00	574000.7532	1211502.7004
11	L	124+00.00	574007.9329	1211552.1822
12	L	124+50.00	574015.1127	1211601.6640
13	L	125+00.00	574022.2924	1211651.1458
14	L	125+50.00	574029.4722	1211700.6277
15	L	126+00.00	574036.6520	1211750.1095
16	L	126+50.00	574043.8317	1211799.5913
17	L	127+00.00	574051.0115	1211849.0731
18	L	127+50.00	574058.1912	1211898.5550
19	L	128+00.00	574065.3710	1211948.0368
20	L	128+50.00	574072.5508	1211997.5186
21	L	129+00.00	574079.7305	1212047.0004
22	L	129+50.00	574086.9103	1212096.4823
23	L	130+00.00	574094.0900	1212145.9641
24	L	130+50.00	574101.2698	1212195.4459
25	L	131+00.00	574108.4496	1212244.9277
26	L	131+50.00	574115.6293	1212294.4096
27	L	132+00.00	574122.8091	1212343.8914
28	L	132+50.00	574129.9888	1212393.3732
29	L	133+00.00	574137.1686	1212442.8550
30	L	133+50.00	574144.3484	1212492.3369
31	L	134+00.00	574151.5281	1212541.8187
32	L	134+50.00	574158.7079	1212591.3005
33	L	135+00.00	574165.8876	1212640.7823
34	L	135+50.00	574173.0674	1212690.2642
35	L	136+00.00	574180.2472	1212739.7460
36	L	136+50.00	574187.4269	1212789.2278
37	L	137+00.00	574194.6067	1212838.7096
38	L	137+50.00	574201.7864	1212888.1915
39	L	138+00.00	574208.9662	1212937.6733
40	L	138+50.00	574216.1460	1212987.1551
41	L	139+00.00	574223.3257	1213036.6369
42	L	139+50.00	574230.5055	1213086.1188
43	L	140+00.00	574237.6853	1213135.6006
44	L	140+50.00	574244.8650	1213185.0824
45	L	141+00.00	574252.0448	1213234.5642
46	L	141+50.00	574259.2245	1213284.0461
47	L	142+00.00	574266.4043	1213333.5279
48	L	142+50.00	574273.5841	1213383.0097
49	L	143+00.00	574280.7638	1213432.4915
50	L	143+50.00	574287.9436	1213481.9734
51	L	144+00.00	574295.1233	1213531.4552
52	L	144+50.00	574302.3031	1213580.9370
53	L	145+00.00	574309.4829	1213630.4188
54	L	145+50.00	574316.6626	1213679.9007
55	L	146+00.00	574323.8424	1213729.3825
56	L	146+50.00	574331.0221	1213778.8643
57	L	147+00.00	574338.2019	1213828.3461
58	L	147+50.00	574345.3817	1213877.8280
59	L	148+00.00	574352.5614	1213927.3098
60	L	148+50.00	574359.7412	1213976.7915
61	L	149+00.00	574366.9210	1214026.2733
62	L	149+50.00	574374.1007	1214075.7551
63	L	150+00.00	574381.2805	1214125.2369
64	L	150+50.00	574388.4603	1214174.7187
65	L	151+00.00	574395.6401	1214223.2005
66	L	151+50.00	574402.8199	1214272.6823
67	L	152+00.00	574410.0000	1214321.1641
68	L	152+50.00	574417.1797	1214370.6459
69	L	153+00.00	574424.3595	1214419.1277
70	L	153+50.00	574431.5393	1214468.6095
71	L	154+00.00	574438.7191	1214517.0913
72	L	154+50.00	574445.8989	1214566.5731
73	L	155+00.00	574453.0787	1214615.0549
74	L	155+50.00	574460.2585	1214664.5367
75	L	156+00.00	574467.4383	1214713.0185
76	L	156+50.00	574474.6181	1214762.5003
77	L	157+00.00	574481.7979	1214811.9821
78	L	157+50.00	574488.9777	1214869.4639
79	L	158+00.00	574496.1575	1214918.9457
80	L	158+50.00	574503.3373	1214967.4275
81	L	159+00.00	574510.5171	1215016.9093
82	L	159+50.00	574517.6969	1215065.3911

Point #	Chain	Station	Northing (Y)	Easting (X)
83	L	160+00.00	574676.9149	1215076.7172
84	L	160+50.00	574699.0755	1215121.5375
85	L	161+00.00	574721.9126	1215166.0169
86	L	161+50.00	574745.4210	1215210.1452
87	L	162+00.00	574769.5953	1215253.9123
88	L	162+50.00	574794.4299	1215297.3080
89	L	163+00.00	574819.9192	1215340.3226
90	L	163+50.00	574846.0572	1215382.9460
91	L	164+00.00	574872.8380	1215425.1685
92	L	164+50.00	574900.2555	1215466.9804
93	L	165+00.00	574928.2994	1215508.3748
94	L	165+50.00	574956.9033	1215549.3843
95	L	166+00.00	574985.9604	1215590.0742
96	L	166+50.00	575015.3649	1215630.5139
97	L	167+00.00	575045.0131	1215670.7752
98	L	167+50.00	575074.8027	1215710.9321
99	L	168+00.00	575104.6358	1215751.0568
100	L	168+50.00	575134.4699	1215791.1806
101	L	169+00.00	575164.3041	1215831.3045
102	L	169+50.00	575194.1382	1215871.4284
103	L	170+00.00	575223.9723	1215911.5523
104	L	170+50.00	575253.8064	1215951.6761
105	L	171+00.00	575283.6406	1215991.8000
106	L	171+50.00	575313.4747	1216031.9239
107	L	172+00.00	575343.3088	1216072.0477
108	L	172+50.00	575373.1429	1216112.1716
109	L	173+00.00	575402.9770	1216152.2955
110	L	173+50.00	575432.8112	1216192.4194
111	L	174+00.00	575462.6453	1216232.5432
112	L	174+50.00	575492.4794	1216272.6671
113	L	175+00.00	575522.3135	1216312.7910
114	L	175+50.00	575552.1476	1216352.9149
115	L	176+00.00	575581.9818	1216393.0387
116	L	176+50.00	575611.8159	1216433.1626
117	L	177+00.00	575641.6499	1216473.2865
118	L	177+50.00	575671.4841	1216513.4104
119	L	178+00.00	575701.3182	1216553.5343
120	L	178+50.00	575731.1523	1216593.6582
121	L	179+00.00	575760.9864	1216633.7821
122	L	179+50.00	575790.8205	1216673.9060
123	L	180+00.00	575820.6546	1216714.0299
124	L	180+50.00	575850.4887	1216754.1538
125	L	181+00.00	575880.3228	1216794.2777
126	L	181+50.00	575910.1569	1216834.4016
127	L	182+00.00	575940.0000	1216874.5255
128	L	182+50.00	575969.8441	1216914.6494
129	L	183+00.00	575999.6882	1216954.7733
130	L	183+50.00	576029.5323	1217000.8972
131	L	184+00.00	576059.3764	1217041.0211
132	L	184+50.00	576089.2205	1217081.1450
133	L	185+00.00	576119.0646	1217121.2689
134	L	185+50.00	576148.9087	1217161.3928
135	L	186+00.00	576178.7528	1217201.5167
136	L	186+50.00	576208.5969	1217241.6406
137	L	187+00.00	576238.4410	1217281.7645
138	L	187+50.00	576268.2851	1217321.8884
139	L	188+00.00	576298.1292	1217362.0123
140	L	188+50.00	576327.9733	1217402.1362
141	L	189+00.00	576357.8174	1217442.2601
142	L	189+50.00	576387.6615	1217482.3840
143	L	190+00.00	576417.5056	1217522.5079
144	L	190+50.00	576447.3497	1217562.6318
145	L	191+00.00	576477.1938	1217602.7557
146	L	191+50.00	576507.0379	1217642.8796
147	L	192+00.00	576536.8820	1217682.0035
148	L	192+50.00	576566.7261	1217722.1274
149	L	193+00.00	576596.5702	1217762.2513
150	L	193+50.00	576626.4143	1217802.3752
151	L	194+00.00	576656.2584	1217842.4991
152	L	194+50.00	576686.1025	1217882.6230
153	L	195+00.00	576715.9466	1217922.7469
154	L	195+50.00	576745.7907	1217962.8708
155	L	196+00.00	576775.6348	1218002.9947
156	L	196+50.00	576805.4789	1218043.1186
157	L	197+00.00	576835.3230	1218083.2425
158	L	197+50.00	576865.1671	1218123.3664
159	L	198+00.00	576895.0112	1218163.4903
160	L	198+50.00	576924.8553	1218203.6142
161	L	199+00.00	576954.7000	1218243.7381
162	L	199+50.00	576984.5441	1218283.8620
163	L	200+00.00	577014.3882	1218323.9859
164	L	200+50.00	577044.2323	1218364.1098

Point #	Chain	Station	Northing (Y)	Easting (X)
165	L	201+00.00	577074.0824	1218404.2297
166	L	201+50.00	577103.9265	1218444.3536
167	L	202+00.00	577133.7706	1218484.4775
168	L	202+50.00	577163.6147	1218524.6014
169	L	203+00.00	577193.4588	1218564.7253
170	L	203+50.00	577223.3029	1218604.8492
171	L	204+00.00	577253.1470	1218644.9731
172	L	204+50.00	577282.9911	1218685.0970
173	L	205+00.00	577312.8352	1218725.2209
174	L	205+50.00	577342.6793	1218765.3448
175	L	206+00.00	577372.5234	1218805.4687
176	L	206+50.00	577402.3675	1218845.5926
177	L	207+00.00	577432.2116	1218885.7165
178	L	207+50.00	577462.0557	1218925.8404
179	L	208+00.00	577491.9000	1218965.9643
180	L	208+50.00	577521.7441	1219006.0882
181	L	209+00.00	577551.5882	1219046.2121
EQUALITY 209+00 -L- LB=208+53.22 -L- LA				
182	L	209+00.00	576975.6754	1219408.2442
183	L	209+50.00	576990.2876	1219456.0614
184	L	210+00.00	577004.8998	1219503.8786
185	L	210+50.00	577	

CODE	PAVEMENT SCHEDULE
C1	PROP. APPROX. 3.0" ASPHALT CONC. SURFACE COURSE, TYPE S9.5B, AT AN AVERAGE RATE OF 168 LBS. PER SQ. YD IN EACH OF TWO LAYERS.
C2	PROP. VAR. DEPTH ASPHALT CONC. SURFACE COURSE, TYPE S9.5B, AT AN AVERAGE RATE OF 112 LBS. PER SQ. YD. PER 1" DEPTH TO BE PLACED IN LAYERS NOT TO EXCEED 2" IN DEPTH.
D1	PROP. APPROX. 2.5" ASPHALT CONC. INTERMEDIATE COURSE, TYPE I19.0B, AT AN AVERAGE RATE OF 285 LBS. PER SQ. YD.
D2	PROP. VAR. DEPTH ASPHALT CONC. INTERMEDIATE COURSE, TYPE I19.0B, AT AN AVERAGE RATE OF 114 LBS. PER SQ. YD. PER 1" DEPTH TO BE PLACED IN LAYERS NOT LESS THAN 2.5" OR GREATER THAN 4" IN DEPTH.
E1	PROP. APPROX. 4.0" ASPHALT CONC. BASE COURSE, TYPE B25.0B, AT AN AVERAGE RATE OF 456 LBS. PER SQ. YD.
E2	PROP. VAR. DEPTH ASPHALT CONC. BASE COURSE, TYPE B25.0B, AT AN AVERAGE RATE OF 114 LBS. PER SQ. YD. PER 1" DEPTH TO BE PLACED IN LAYERS NOT GREATER THAN 5.5" OR LESS THAN 3" IN DEPTH.
J1	PROP. 8.0" AGGREGATE BASE COURSE
J2	VARIABLE AGGREGATE BASE COURSE
R1	SHOULDER BERM GUTTER
T	EARTH MATERIAL
U	EXISTING PAVEMENT
W	VARIABLE DEPTH ASPHALT PAVEMENT (SEE WEDGING DETAIL)

Note: Pavement Edge Slopes are 1:1 Unless Shown Otherwise

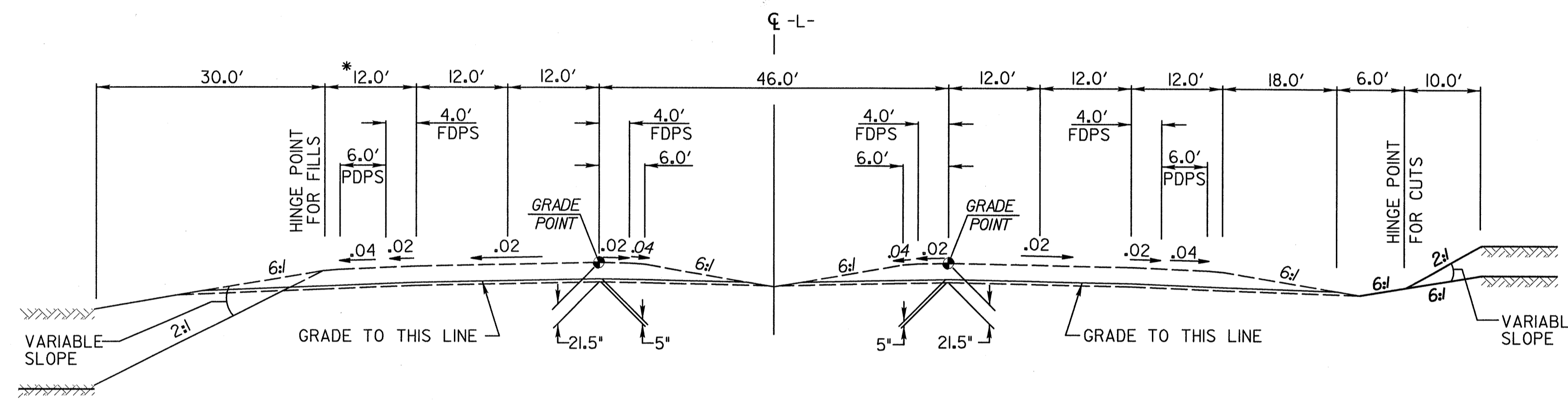

* 15.0' WHERE WIDENED FOR GUARDRAIL

TYPICAL SECTION NO. #1
 USE TYPICAL SECTION #1:
 FROM -L- STA. 119+00.00 TO STA. 156+47.10 (-WB- LANE BRIDGE)
 FROM -L- STA. 159+03.90 (-WB- LANE BRIDGE) TO STA. 209+00.00

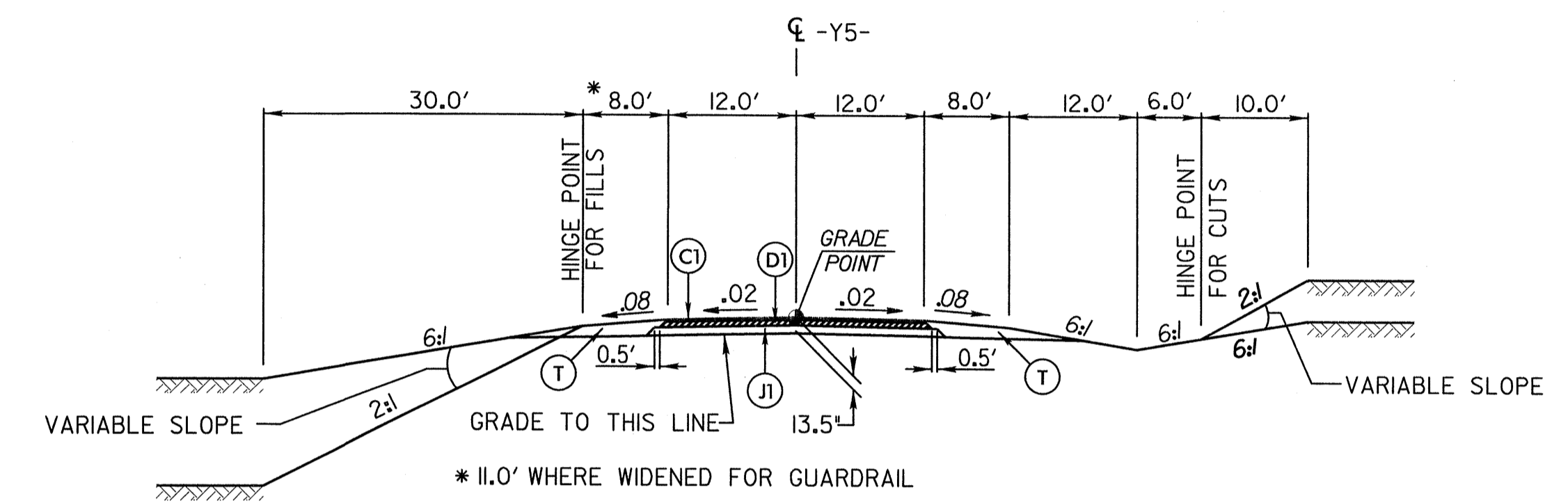

TYPICAL SECTION NO. #3
 USE TYPICAL SECTION #3:
 FROM STA. -Y5- 12+50.00 TO STA. 15+90.72 (BRIDGE)
 FROM STA. -Y5- 17+72.06 (BRIDGE) TO STA. 23+00.00

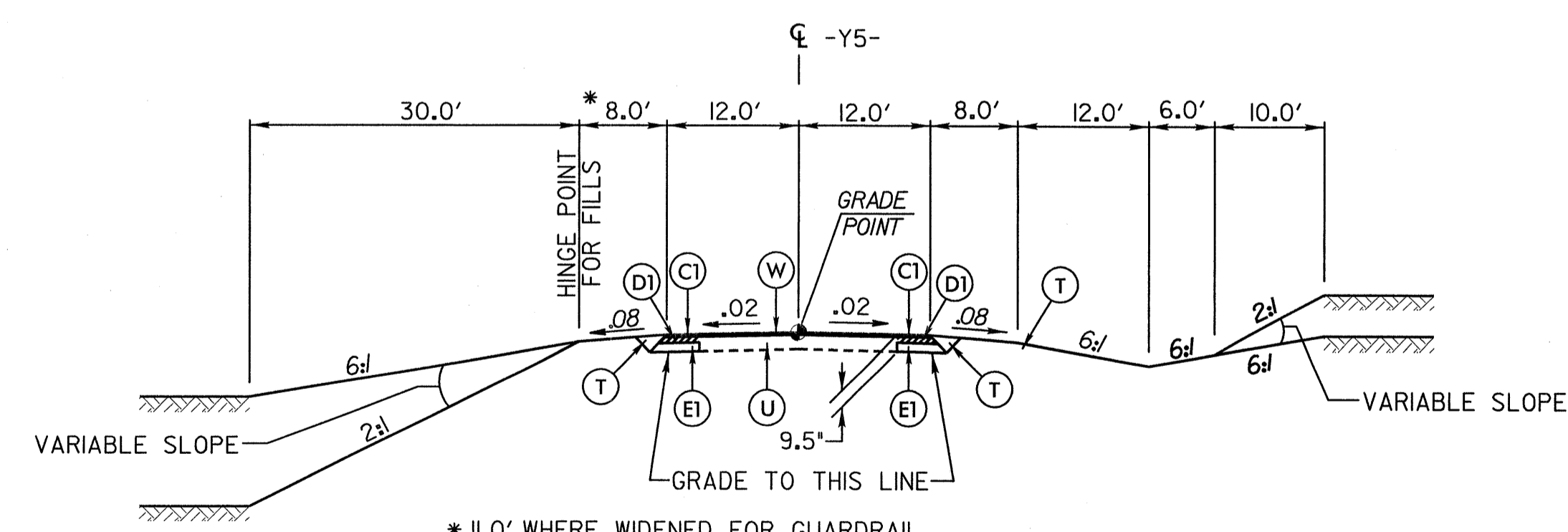

* 11.0' WHERE WIDENED FOR GUARDRAIL

TYPICAL SECTION NO. #2
 USE TYPICAL SECTION #2:
 FROM STA. -Y5- 10+25.62 TO STA. 12+50.00
 FROM STA. -Y5- 23+00.00 TO STA. 24+00.00

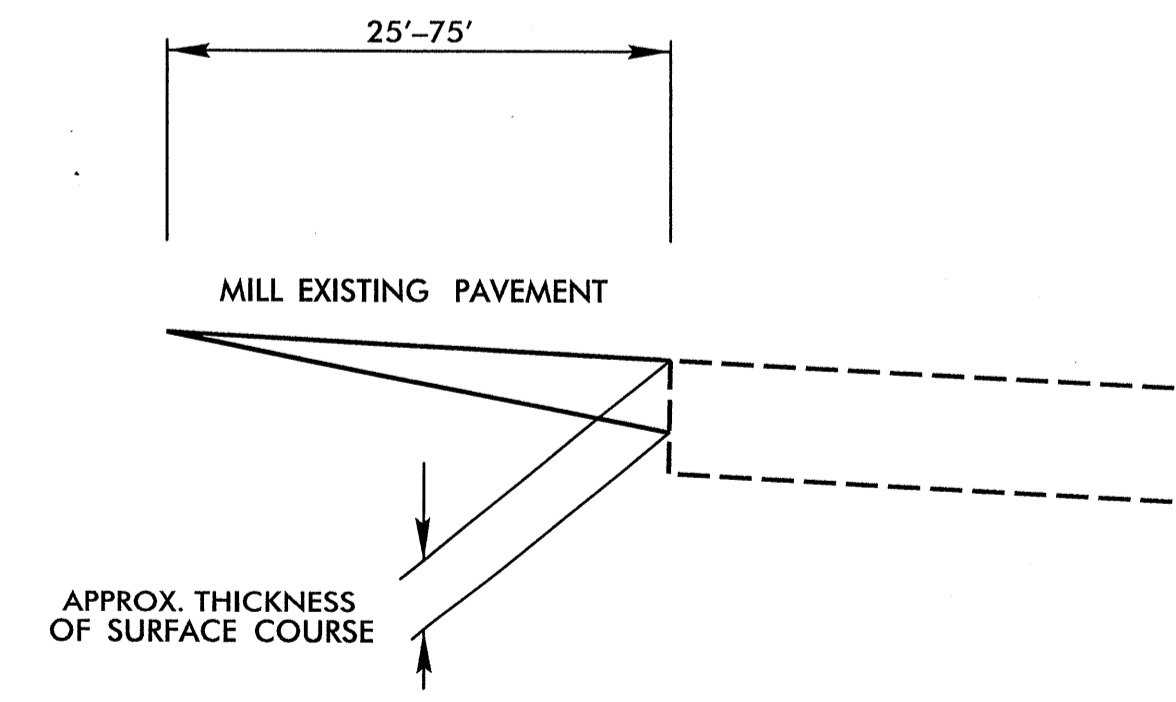

NOTE:
 MILL THE EXISTING PAVEMENT IN ACCORDANCE WITH THE FOLLOWING SKETCH AS DIRECTED BY THE ENGINEER. LOCATIONS SHALL INCLUDE TIES TO EXISTING PAVEMENT AT THE BEGINNING AND END OF -Y5-. PERFORM THE WORK IN ACCORDANCE WITH SECTION 607 OF THE JANUARY 2012 NORTH CAROLINA DEPARTMENT OF TRANSPORTATION STANDARD SPECIFICATIONS FOR ROADS AND STRUCTURES. RESURFACING WILL BE ACCOMPLISHED AT THE SAME TIME AS THE MILLING OPERATION.

NO PAYMENT WILL BE MADE FOR THIS WORK AS IT WILL BE CONSIDERED INCIDENTAL TO THE VARIOUS PAVEMENT ITEMS.

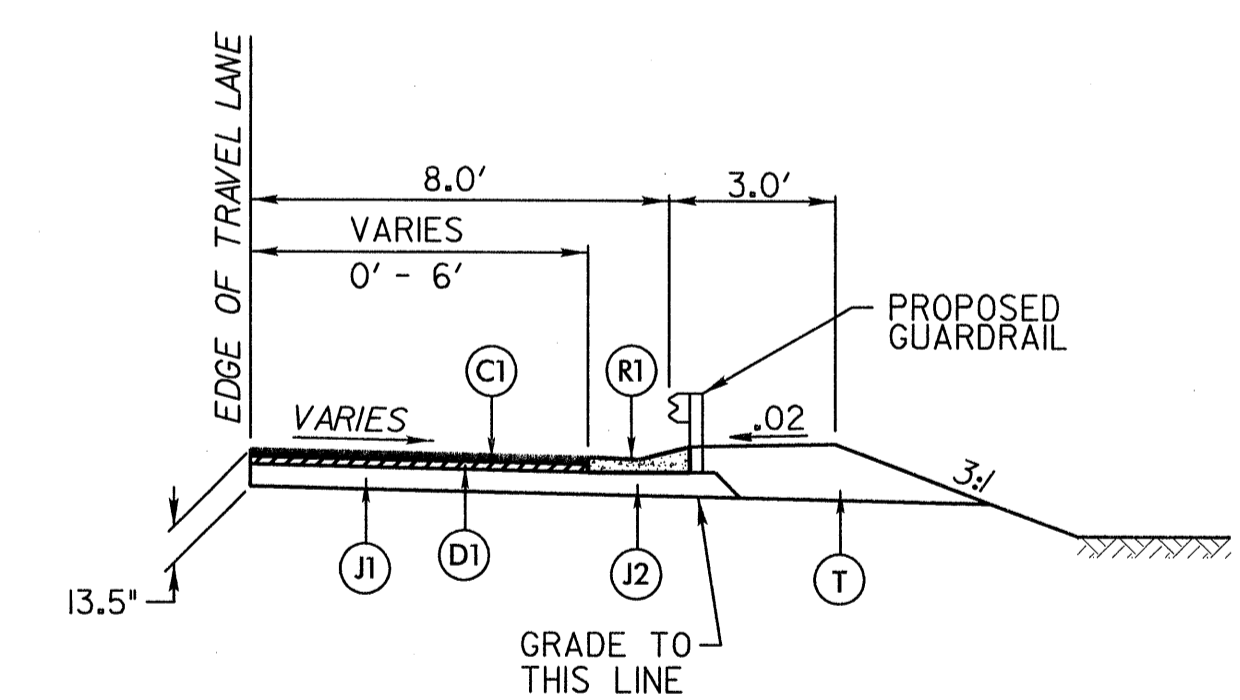

DETAIL OF PAVEMENT WIDENING AT SHOULDER BERM GUTTER
 FROM STA. 14+60 TO STA. 15+76 -Y5- RT.
 FROM STA. 17+86 TO STA. 21+05 -Y5- RT.
 FROM STA. 17+86 TO STA. 18+29 -Y5- LT.

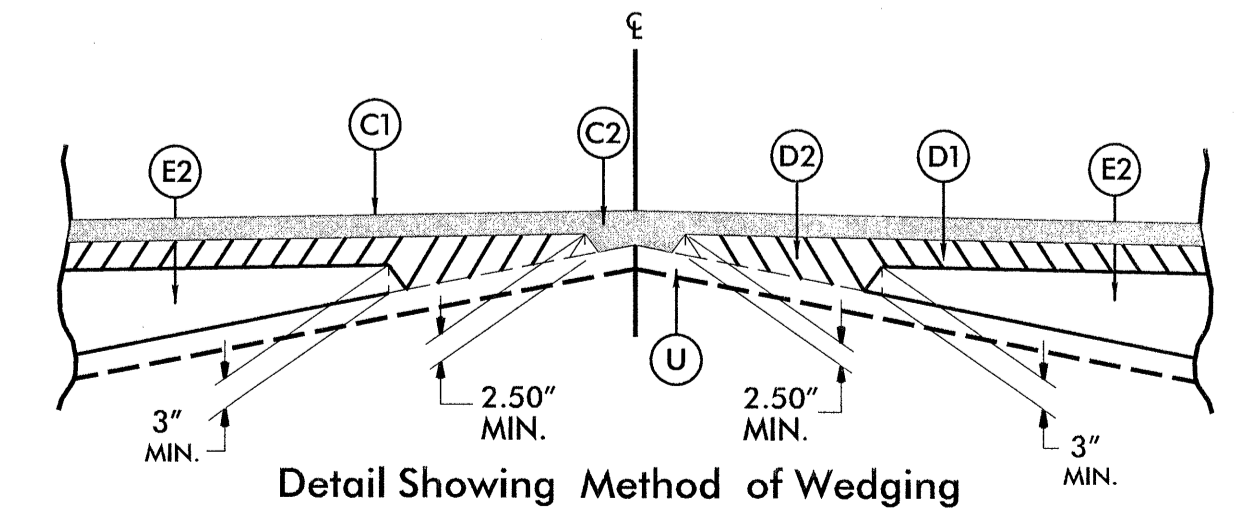

Detail Showing Method of Wedging

6/22/99

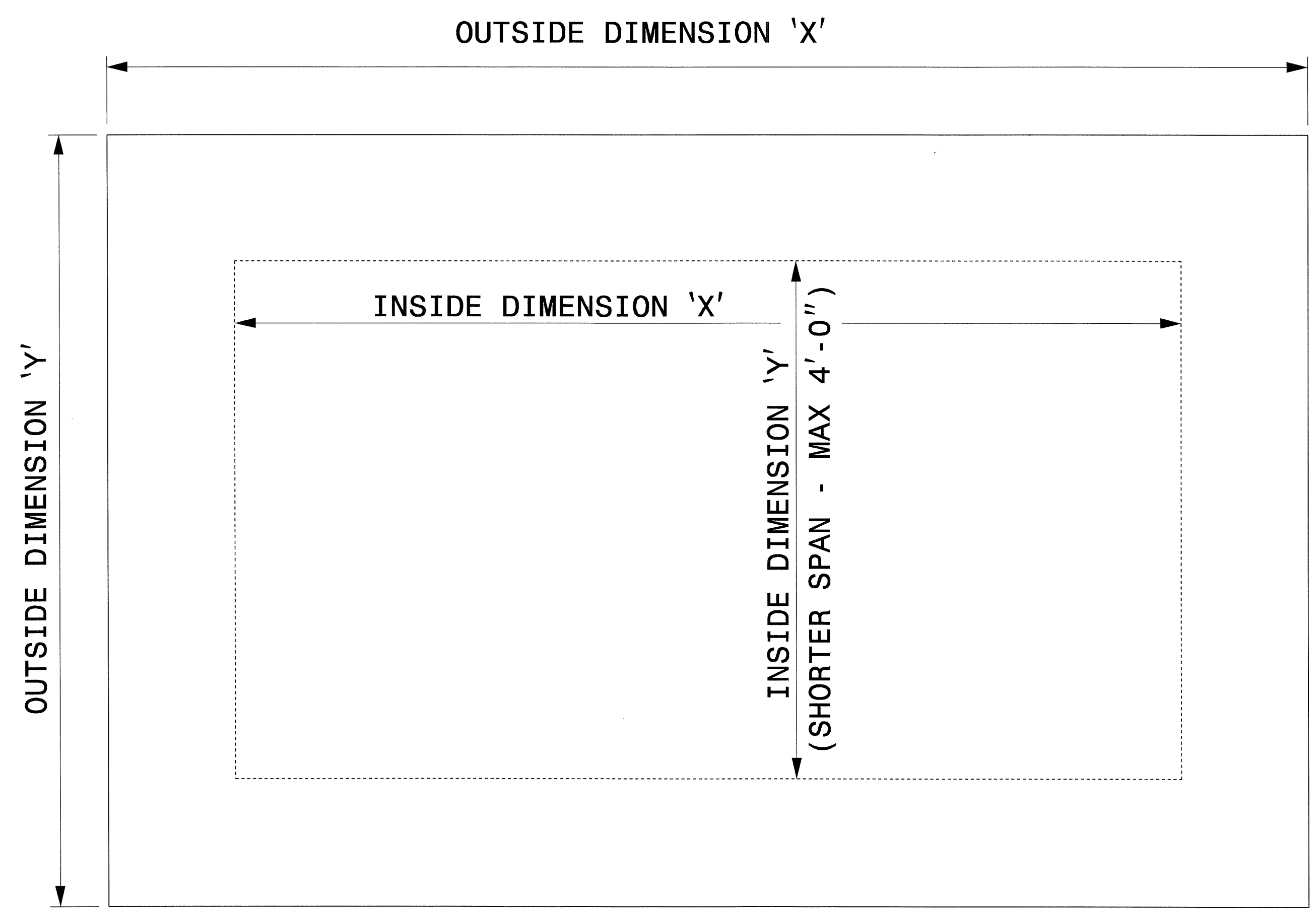

GENERAL NOTES:

- USE GRADE A36 STEEL
- STEEL COVERS ARE FOR TEMPORARY USE DURING PHASE CONSTRUCTION.
- FILL SHALL BE PLACED DIRECTLY OVER THE STEEL PLATES.
- SEE ROADWAY PLANS AND PROVISIONS FOR LOCATIONS
- QUANTITIES TO BE PAID FOR AT THE UNIT PRICE BID PER EACH.

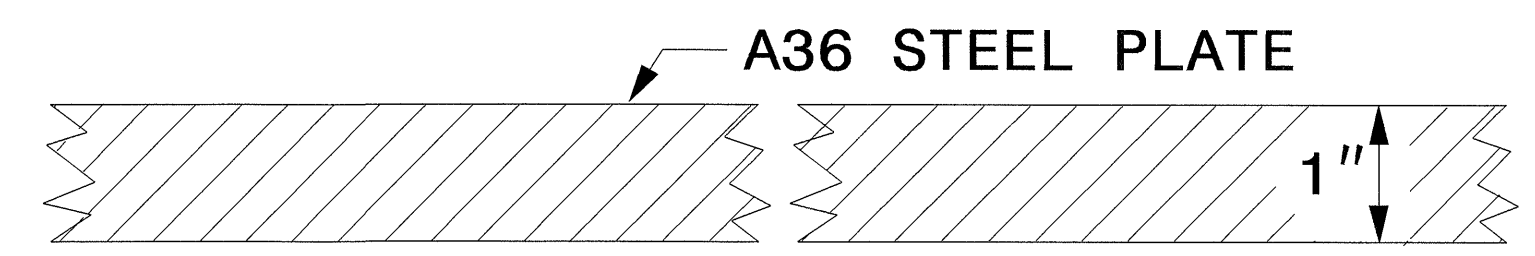

SECTION VIEW OF STEEL TOP PLATE

PLAN VIEWS

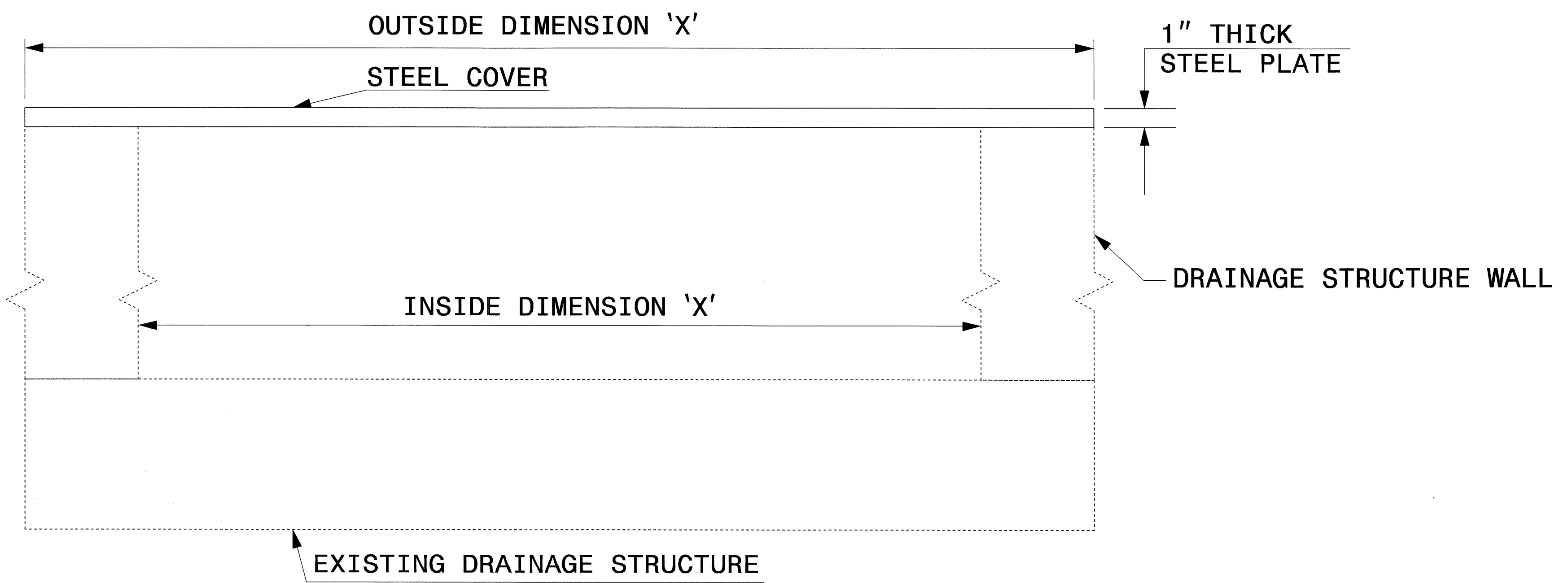

ELEVATION VIEWS

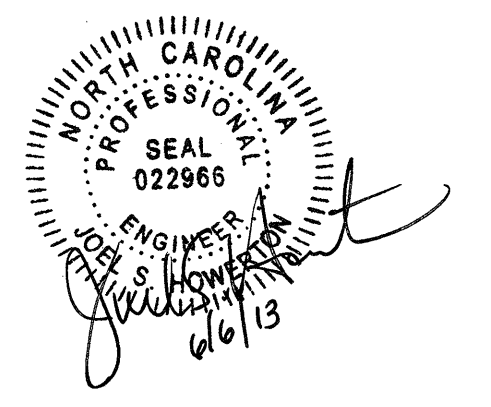

CONTRACT STANDARDS AND DEVELOPMENT UNIT	
Office 919-707-6950 FAX 919-250-4119	
DETAIL OF TEMPORARY 1" STEEL COVER OVER DRAINAGE STRUCTURE	
ORIGINAL BY: E.E. WARD	DATE: 2-2-98
MODIFIED BY: <i>E.E. Ward</i>	DATE: <i>3/15/13</i>
CHECKED BY: <i>E.E. Ward</i>	DATE: <i>3/15/13</i>
FILE SPEC.: e:\c:\usr\details\metric\stand\stlcvr2.dgn	

P:\CADD\2013\2707AB\2707AB.dwg
 3/15/13 10:10:11 AM
 E.E. WARD
 022966

BILL OF MATERIAL

BAR	NO.	SIZE	LENGTH	WEIGHT
A	28	5	5'-10"	170
B	32	5	11'-8"	389
C	96	5	5'-0"	501
E	56	5	4'-7"	234
TOTAL STEEL (lbs.)				1294
BILL OF MATERIAL - CLASS "B" CONCRETE				
CLASS "B" CONCRETE				10.3 CU.YDS.

NOTE: REBARS CROSSING PIPE OPENINGS OR PASSING WITHIN 2" OF A PIPE SHALL BE CUT, BENT, OR OTHERWISE RESHAPED SO AS TO CLEAR THE OPENING.

GENERAL NOTES:
 ALL EXPOSED CORNERS TO BE CHAMFERED 1".
 CLASS "B" CONCRETE TO BE USED THROUGHOUT.
 IF REINFORCED CONCRETE PIPE IS SET IN BASE SLAB OF BOX, ADD TO BASE SLAB AS SHOWN ON STANDARD DRAWING 840.00.
 REINFORCING STEEL SHALL BE CUT, BENT, OR RELOCATED TO POSITION PIPE AS DIRECTED BY THE ENGINEER.
 JUNCTION BOX SHALL BE POSITIONED AS FIELD CONDITIONS DICTATE AND AS DIRECTED BY THE ENGINEER.

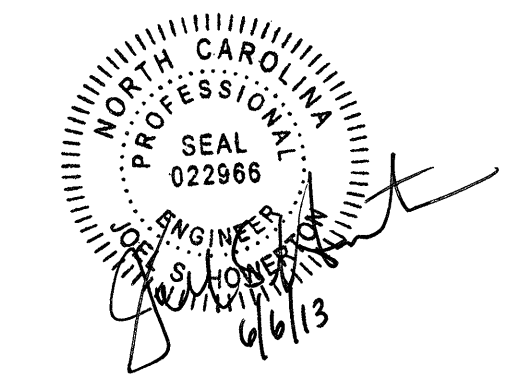
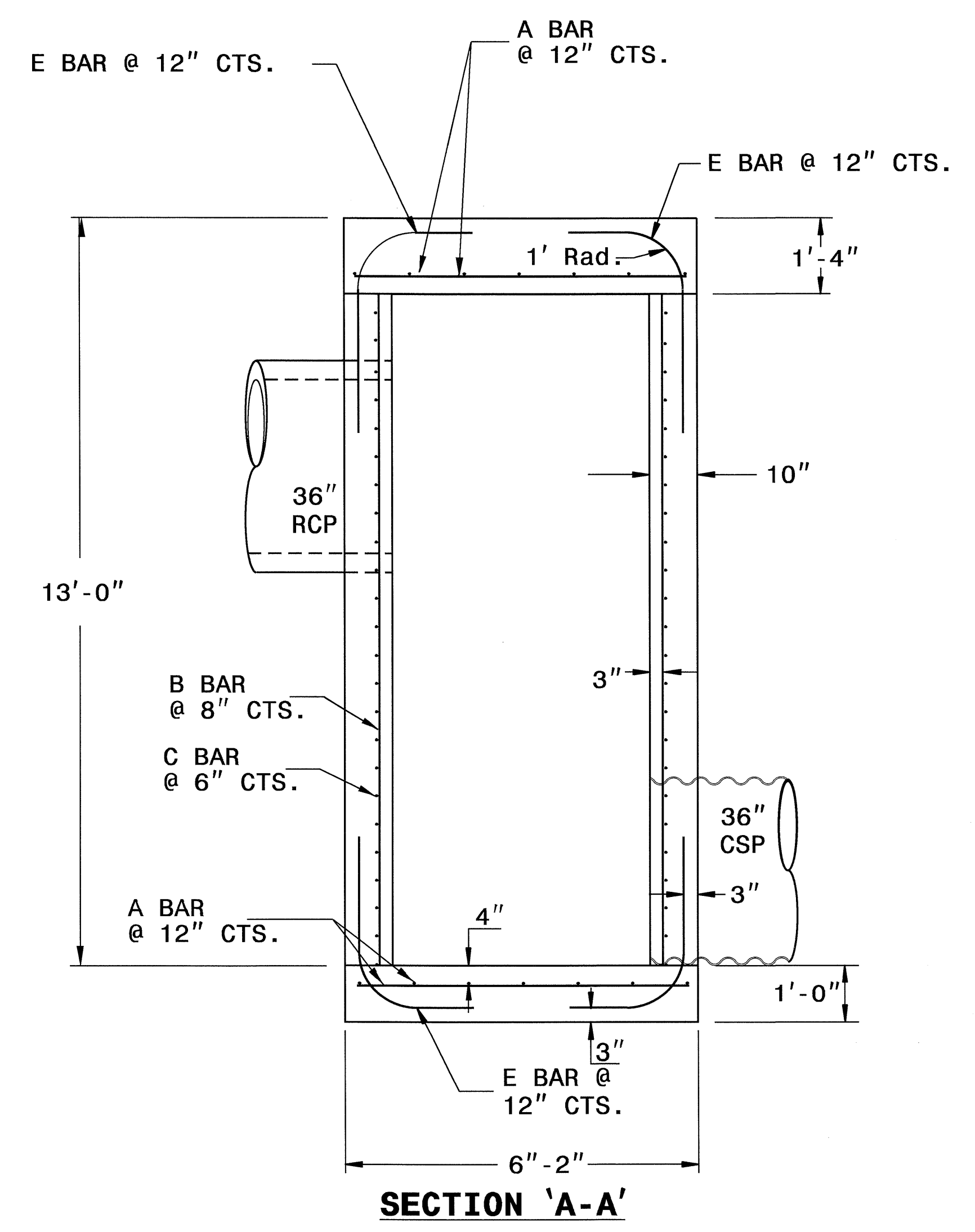
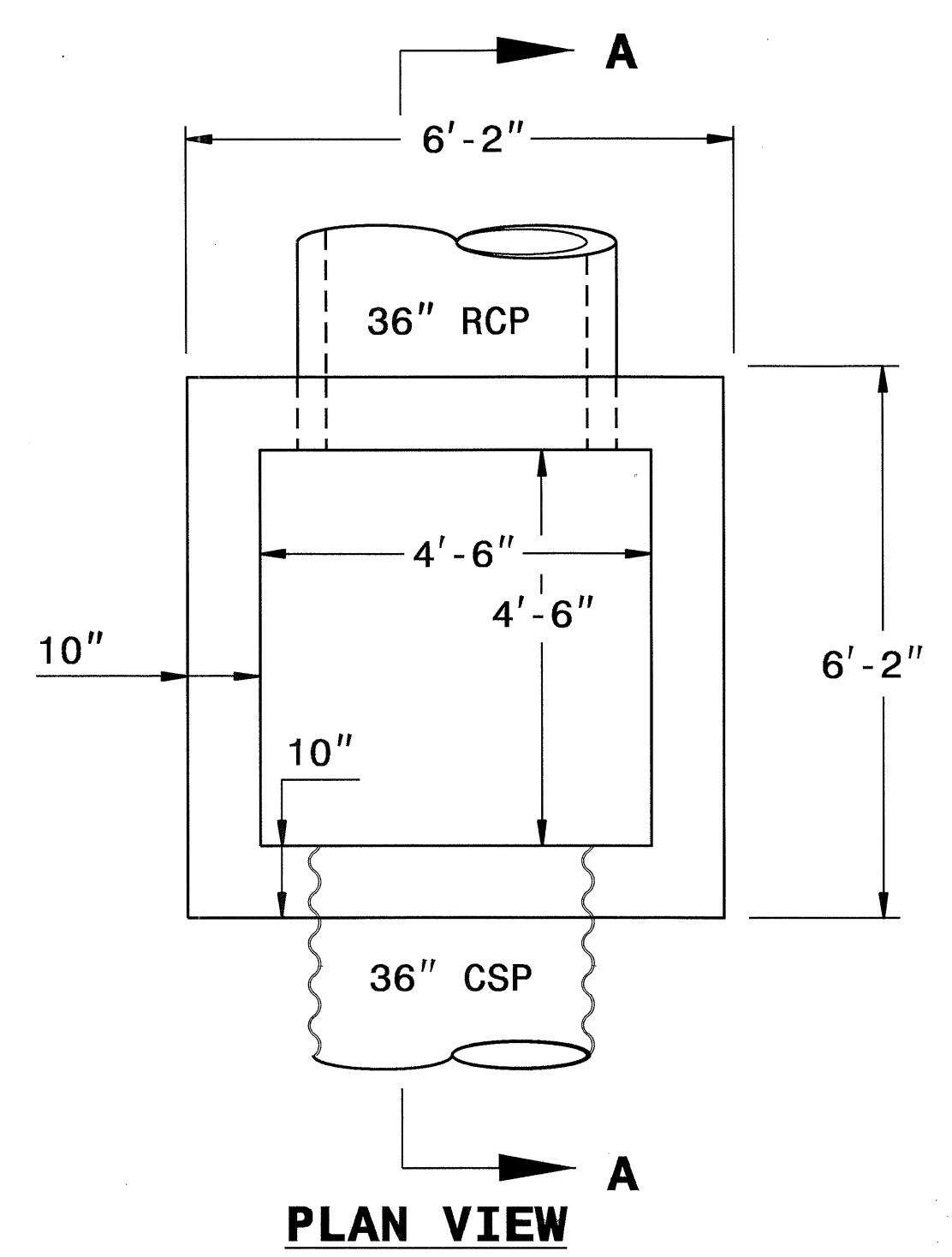

CONTRACTS STANDARDS AND DEVELOPMENT UNIT
 Office 919-707-6950 FAX 919-250-4119

DETAIL OF JUNCTION BOX UNDER 25' FILL

ORIGINAL BY: L.E.R. & T.L. Stephenson DATE: Aug. 1993
 MODIFIED BY: K. Kempf DATE: MAY 2013
 CHECKED BY: [Signature] DATE: 5/13/13
 FILE SPEC: details/kkempf/english/jb25'fill.dgn

13-MAY-2013 09:28
 S:\Contracts\Special_Details\kkempf\english\jb25'fill.dgn
 \$\$\$USERNAME\$\$\$

COMPUTED BY: DAP DATE: 5/15/2012

CHECKED BY: STS DATE: 6/1/2012

PROJECT NO.

SHEET NO.

R-2707AB

3-E

STATE OF NORTH CAROLINA DIVISION OF HIGHWAYS

SUMMARY OF WOVEN WIRE FENCE

Station to Station	LOC LT OR RT	A FABRIC L.F.	B END BRACE	C CORNER BRACE	D LINE BRACE	E 4" POSTS	F 5" POSTS
-L- 119+00 TO -L- 156+48.88	LT.	3,825	2	3	13	245	52
-L- 159+02.12 TO -Y5- 15+90.72	LT.	4,670	3	2	16	301	60
-Y5- 15+90.72 TO -L- 209+00.00	LT.	595	2	3	3	31	22
-L- 119+00 TO -L- 156+47.10	RT.	3,945	2	5	13	250	58
-L- 159+03.90 TO -Y5- 17+72.06	RT.	4,595	3	2	15	297	57
-Y5- 17+72.06 TO -L- 209+00.00	RT.	606	2	1	2	36	13
	TOTAL:	18,236	14	16	62	1159	262
	SAY:	18,250				1165	270

SUMMARY OF BREAKING

OF ASPHALT PAVEMENT

LINE	STATION	STATION	LOC	SY
-Y5-	12+50.00	15+90.72	LT. & RT.	808
-Y5-	17+72.06	23+00.00	LT. & RT.	1,062
		TOTAL		1,870
		SAY		1,900

SUMMARY OF SHOULDER BERM GUTTER

LINE	STATION	STATION	LOC	LENGTH
-L-	14+60	15+76	RT.	116
-L-	17+86	21+05	RT.	319
-L-	17+86	18+29	LT.	43
		TOTAL		478.00
		SAY		490

COMPUTED BY: KVN DATE: 6/4/13
 CHECKED BY: SCC DATE: 6/5/13

(8-20-13)

PROJECT NO.
R-2707AB

SHEET NO.
3-G

**STATE OF NORTH CAROLINA
 DIVISION OF HIGHWAYS**

SUMMARY OF SUBSURFACE DRAINAGE

LINE	Station	Station	Location LT/RT/CL	Drain Type* UD/BD/SD	LF
-L-	168+50	169+50	LT/RT	UD	200
CONTINGENCY				UD	1000
TOTAL LF:					1200

*UD = Underdrain
 *BD = Blind Drain
 *SD = Subsurface Drain

**SUMMARY OF
 BRIDGE WAITING PERIODS**

Bridge Description	End Bent/ Bent No.	MONTHS
Station 156+47.10 -L-	EB 1	3 mo
Station 159+03.90 -L-	EB 2	3 mo
Station 156+48.88 -L-	EB 1	3 mo
Station 159+02.12 -L-	EB 2	3 mo

**SUMMARY OF
 SETTLEMENT GAUGES**

Gauge No.	LINE	Approx. Station	Approx. Offset
TOTAL GAUGES (EACH):			

SUMMARY OF ROCK PLATING

LINE	Beginning Slope	Approx. Station	Ending Slope	Approx. Station	Location LT/RT	Rock Plating Detail No. 1/2/3/4	Riprap Class* 1/2/B	SY
TOTAL SY:								

*Use Class 1, 2 or B riprap if riprap class is not shown for rock plating location.

**SUMMARY OF
 EMBANKMENT WAITING PERIODS**

LINE	Station	Station	MONTHS
------	---------	---------	--------

**SUMMARY OF SURCHARGES
 AND SURCHARGE WAITING PERIODS**

LINE	Station	Station	Surcharge Height	MONTHS
------	---------	---------	---------------------	--------

SUMMARY OF REINFORCED SOIL SLOPES (RSS)

LINE	Beginning Slope	Approx. Station	Ending Slope	Approx. Station	Location LT/RT	SY
TOTAL SY:						

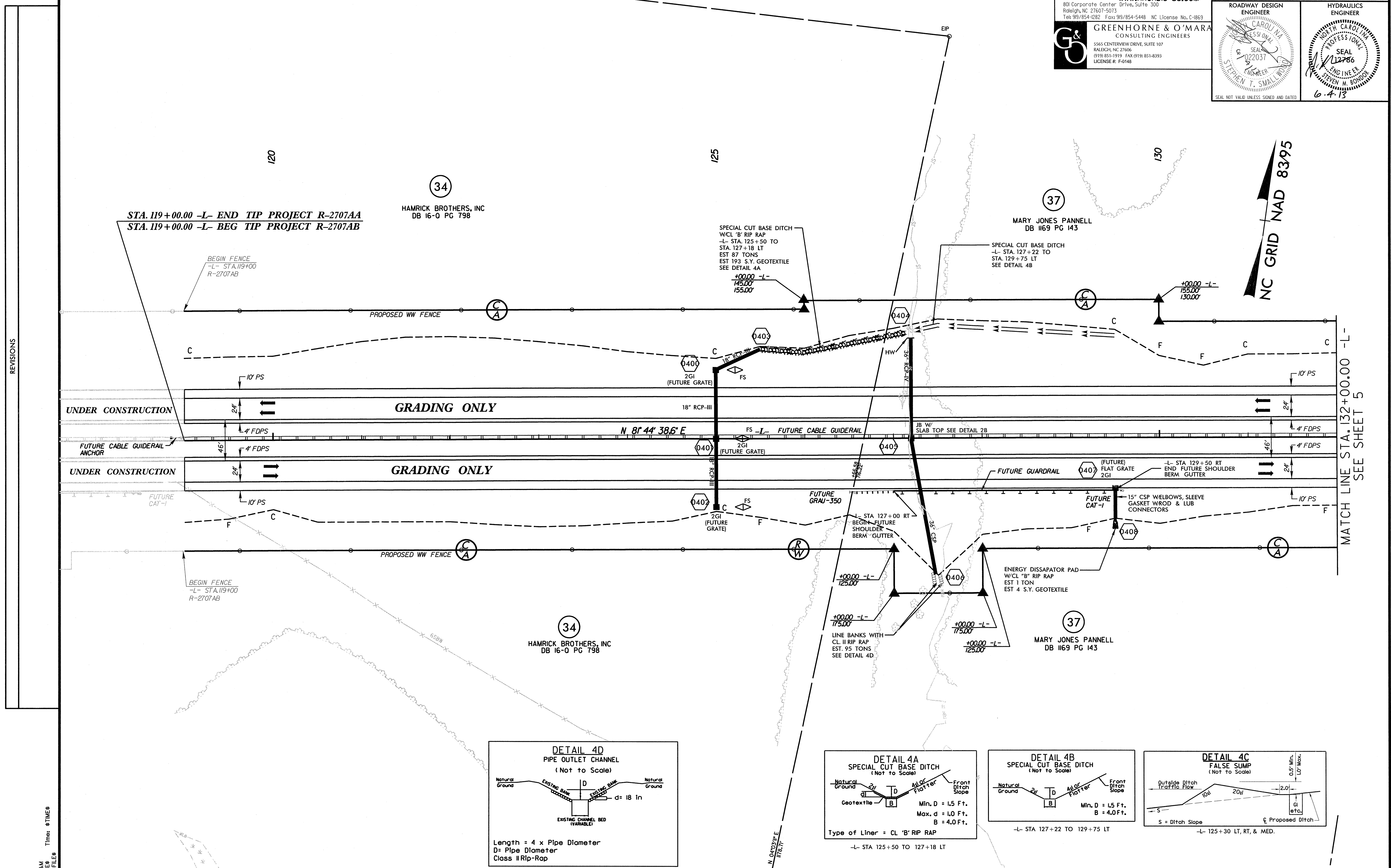

REVISIONS

MATCH LINE STA. 132+00.00 -L- SEE SHEET 5

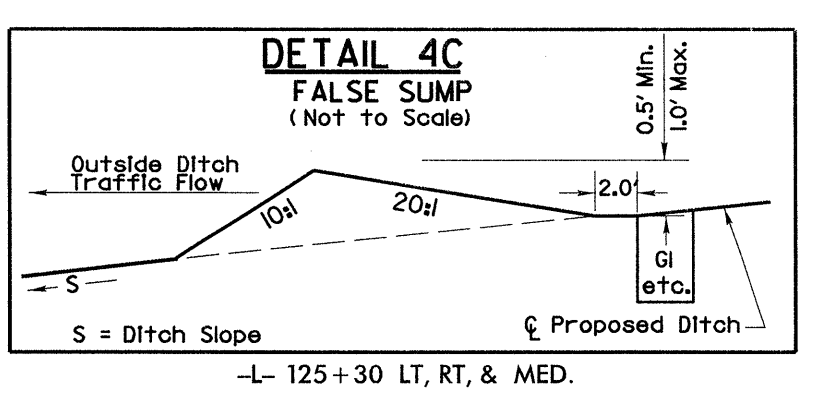
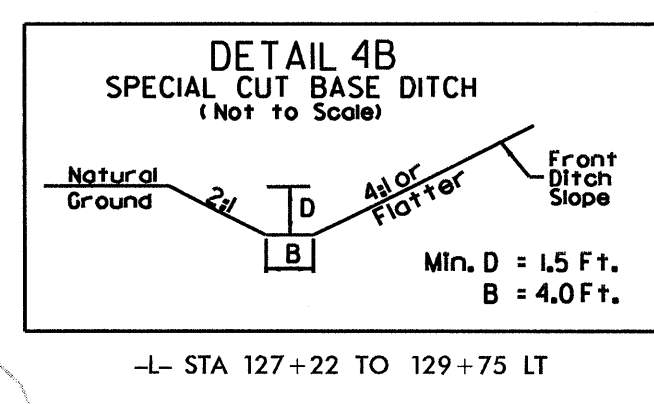
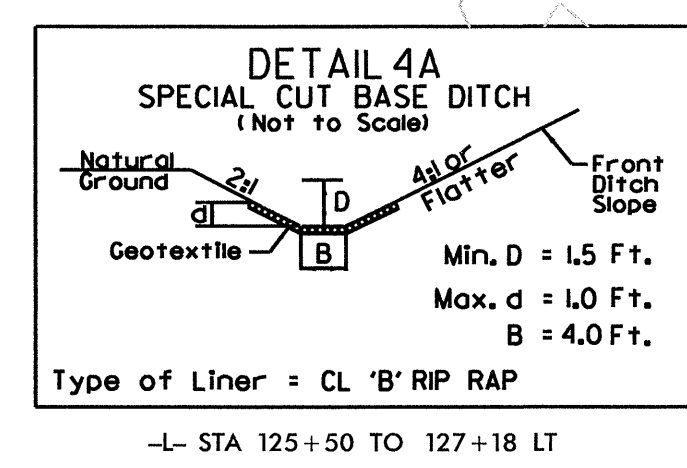
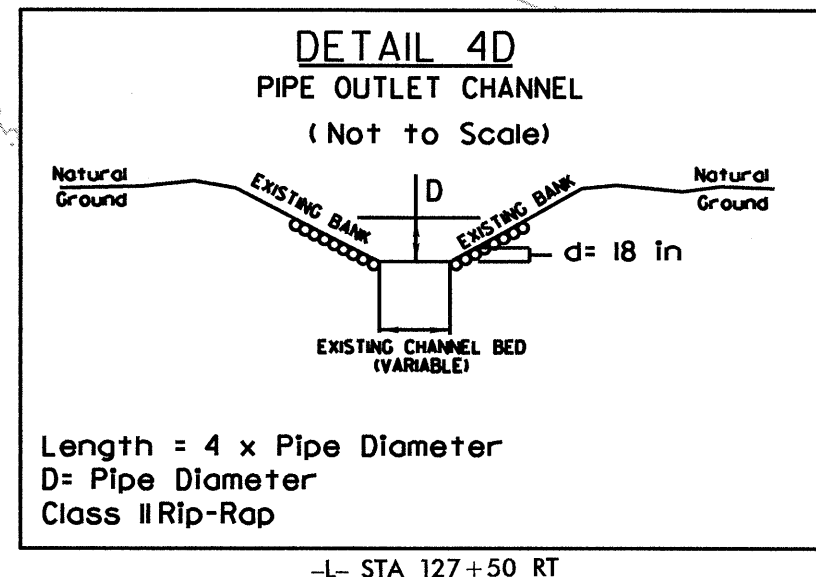

ARCADIS G&M Date: 6/4/13 Time: 10:00 AM Filename: R-2707AB-4.dwg

SEE SHEETS 13 FOR -L- PROFILE

-L-
 PI Sta 157+27.72
 $\Delta = 24^{\circ} 02' 37.9" (LT)$
 $D = 0^{\circ} 45' 14.0"$
 $L = 3,189.30'$
 $T = 1,618.47'$
 $R = 7,600.00'$
 $DS = 70 \text{ MPH}$
 $e = .03$

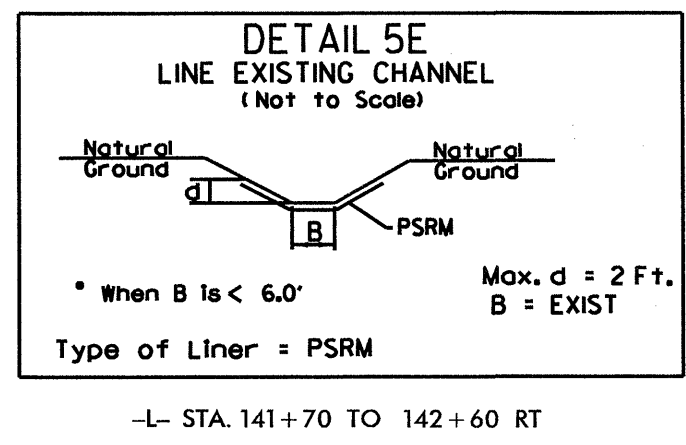
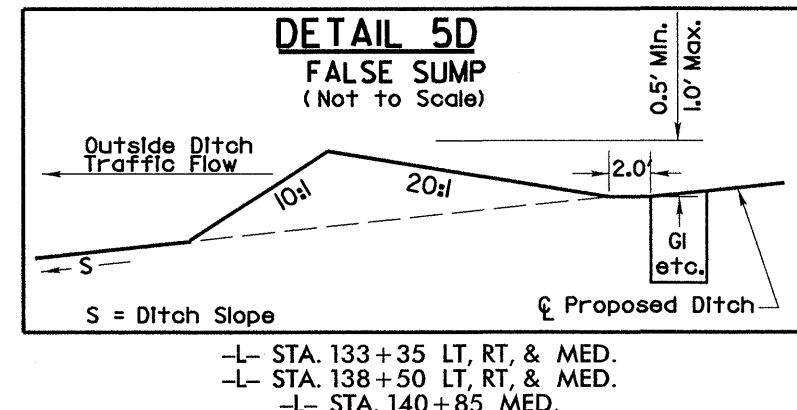
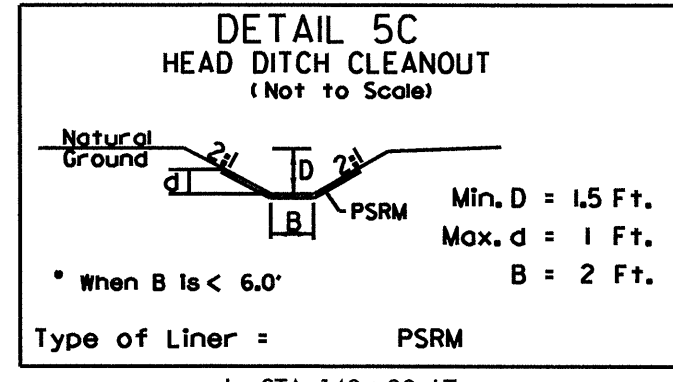
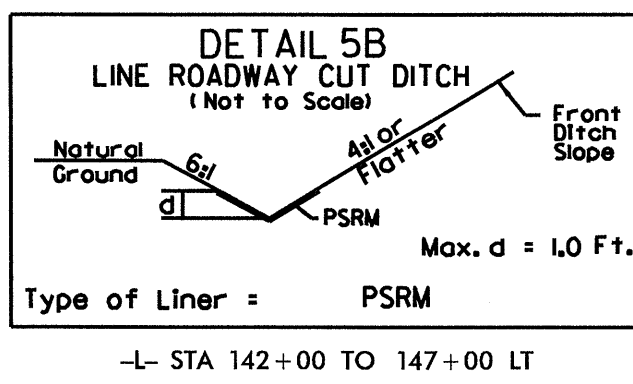
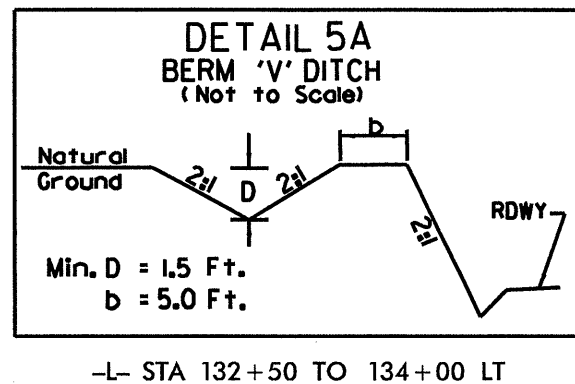

37
 MARY JONES PANNELL
 DB 1169 PG 143

38
 BOBBY LEE BLANTON, SR.
 DB 16-B PG 209

39
 MICHAEL J. RHEA
 DB 1136 PG 1448

NC GRID NAD 83/95

MATCH LINE STA. 132+00.00 -L-
 SEE SHEET 4

MATCH LINE STA. 144+00.00 -L-
 SEE SHEET 6

REVISIONS

ARCADIS G&M
 DATE: 04/11/13
 TIME: 6:15 AM
 FILE: R2707AB_05.dwg

SEE SHEET 13 FOR -L- PROFILE

-L-
 PIs Sta 150+35.23
 $\theta_s = 2^\circ 36' 15.7''$
 Ls = 300.00'
 LT = 200.02'
 ST = 100.02'
 DS = 70 MPH
 e = .06

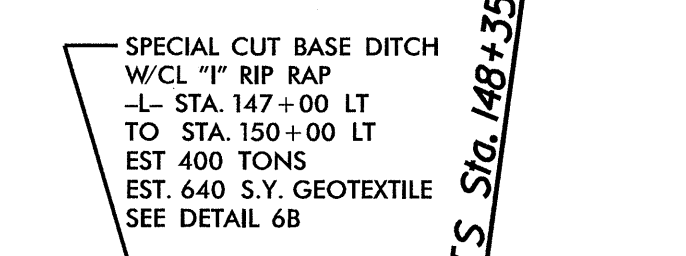
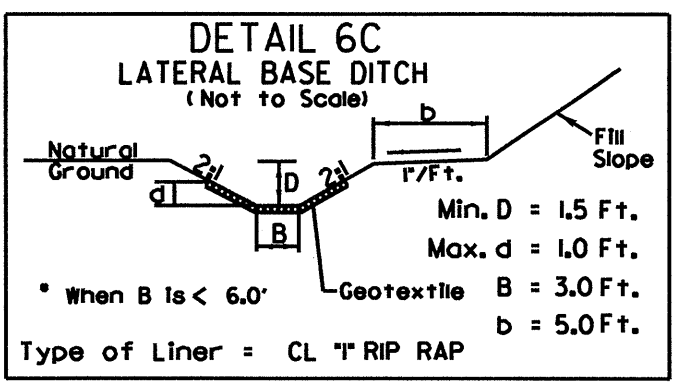
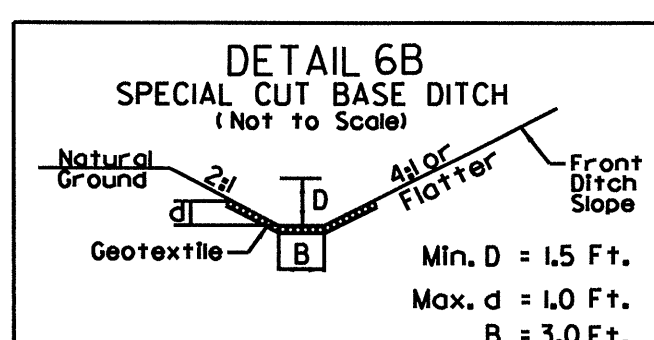
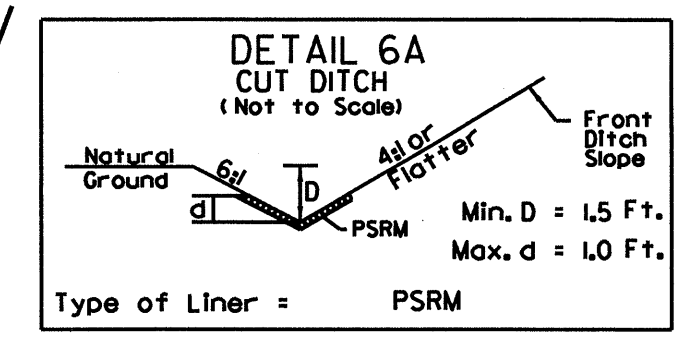

MATCH LINE STA. 144+00.00 -L-
 SEE SHEET 5

MATCH LINE STA. 156+10.00 -L-
 SEE SHEET 7

NC GRID NAD 83/95

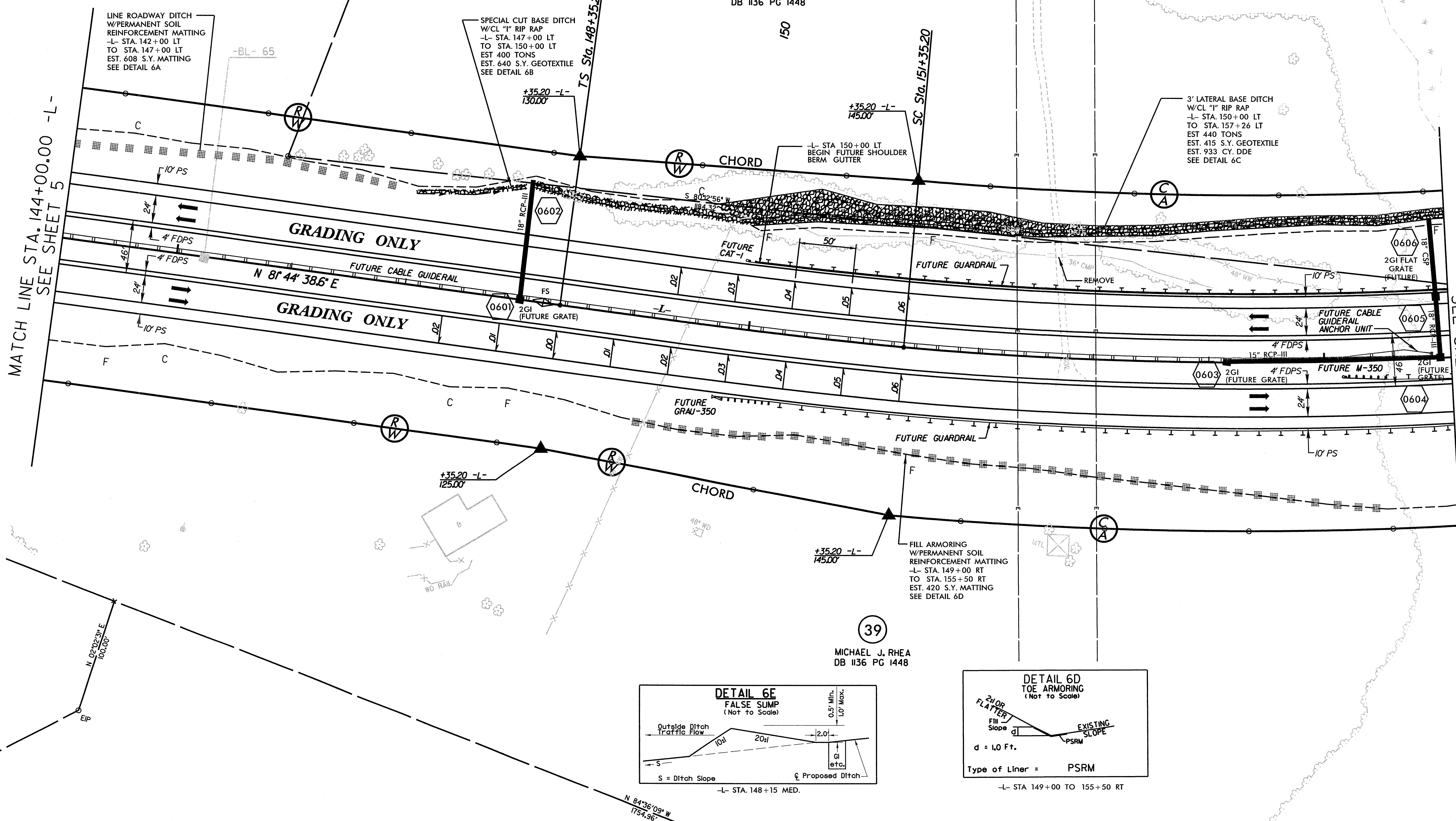

REVISIONS

ARCADIS G&M
 PROJECT NO. 2707AB
 DRAWING NO. 2707AB-12-6
 DATE: 6/4/13
 TIME: 4:00 PM

SEE SHEET 14 FOR -L- PROFILE

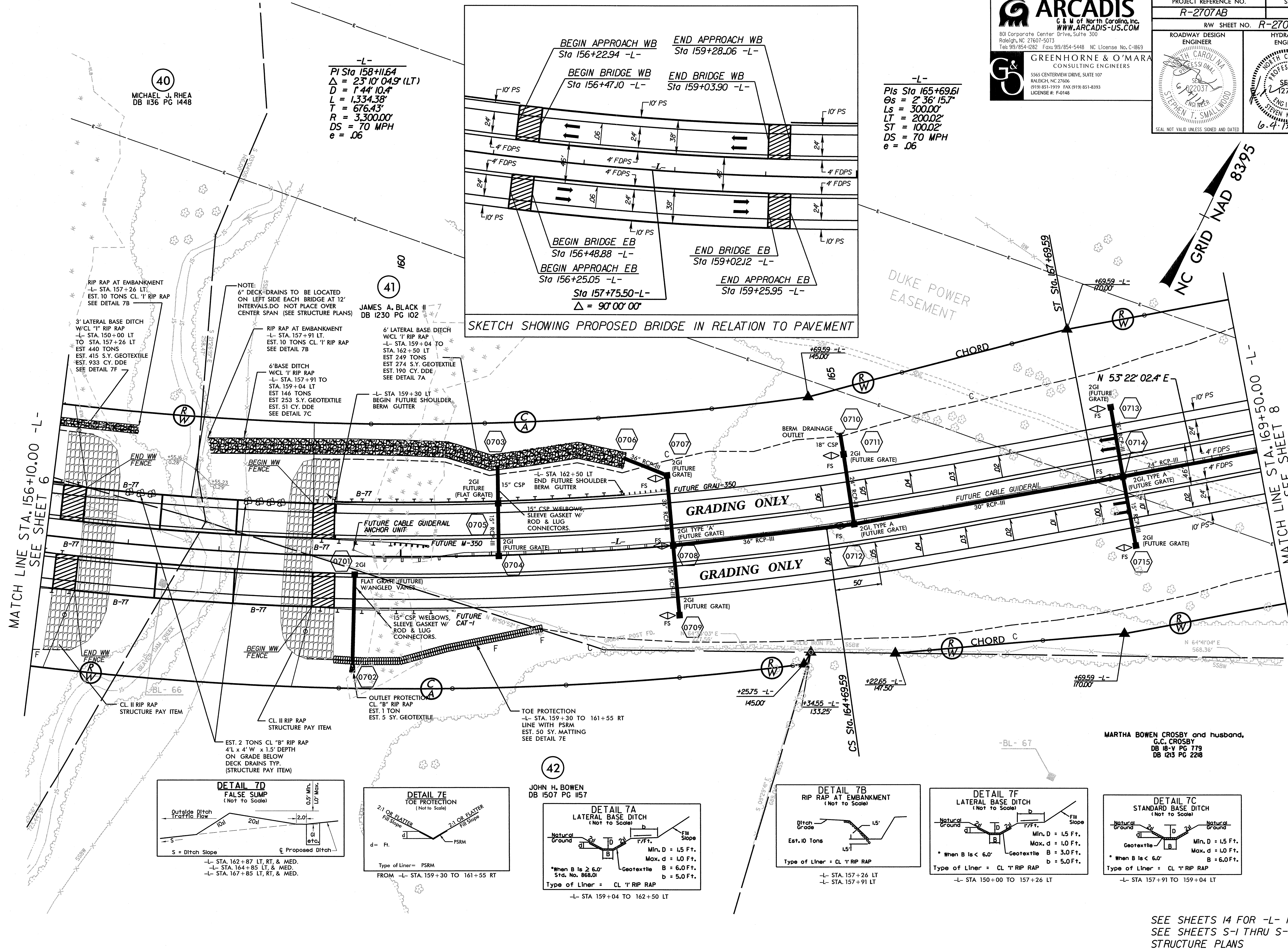

40
 MICHAEL J. RHEA
 DB 1136 PG 1448

-L-
 PI Sta 158+11.64
 $\Delta = 23^{\circ} 10' 04.9''$ (LT)
 D = 1,334.38'
 T = 676.43'
 R = 3,300.00'
 DS = 70 MPH
 e = .06

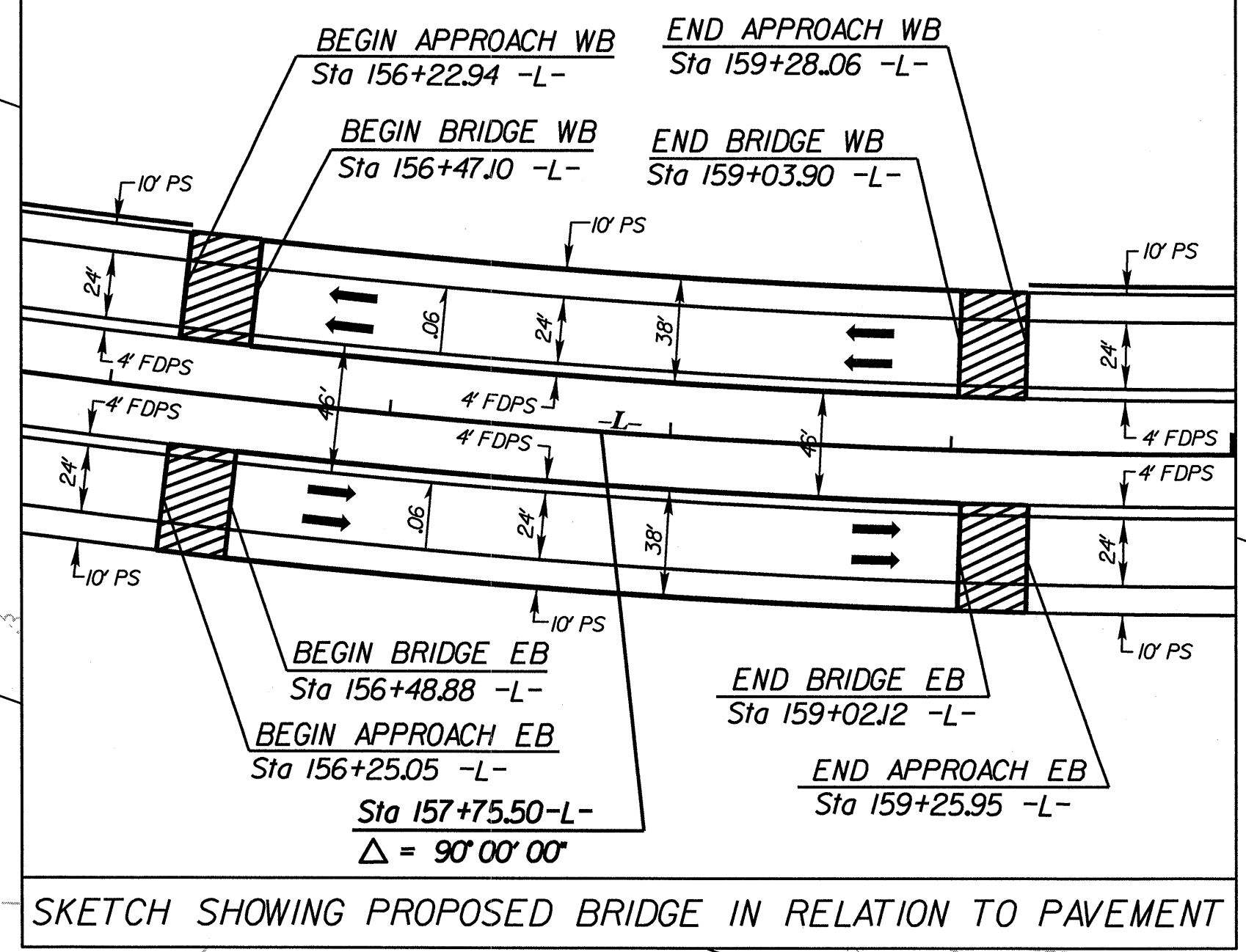

-L-
 PIs Sta 165+69.61
 $\theta_s = 2^{\circ} 36' 15.7''$
 Ls = 300.00'
 LT = 200.02'
 ST = 100.02'
 DS = 70 MPH
 e = .06

NOTE:
 6" DECK DRAINS TO BE LOCATED ON LEFT SIDE EACH BRIDGE AT 12' INTERVALS. DO NOT PLACE OVER CENTER SPAN (SEE STRUCTURE PLANS)

RIP RAP AT EMBANKMENT -L- STA. 157+26 LT. EST. 10 TONS CL. '1' RIP RAP SEE DETAIL 7B

3' LATERAL BASE DITCH W/CL '1' RIP RAP -L- STA. 150+00 LT TO STA. 157+26 LT EST. 440 TONS EST. 415 S.Y. GEOTEXTILE EST. 933 CY. DDE SEE DETAIL 7F

NOTE: 6" DECK DRAINS TO BE LOCATED ON LEFT SIDE EACH BRIDGE AT 12' INTERVALS. DO NOT PLACE OVER CENTER SPAN (SEE STRUCTURE PLANS)

RIP RAP AT EMBANKMENT -L- STA. 157+91 LT. EST. 10 TONS CL. '1' RIP RAP SEE DETAIL 7B

6" BASE DITCH W/CL '1' RIP RAP -L- STA. 157+91 TO STA. 159+04 LT EST. 146 TONS EST. 274 S.Y. GEOTEXTILE EST. 51 CY. DDE SEE DETAIL 7C

6" LATERAL BASE DITCH W/CL '1' RIP RAP -L- STA. 159+04 TO STA. 162+50 LT EST. 249 TONS EST. 190 CY. DDE SEE DETAIL 7A

-L- STA. 159+30 LT BEGIN FUTURE SHOULDER, BERM GUTTER

CL. II RIP RAP STRUCTURE PAY ITEM

EST. 2 TONS CL. "B" RIP RAP 4'L x 4' W x 1.5' DEPTH ON GRADE BELOW DECK DRAINS TYP. (STRUCTURE PAY ITEM)

TOE PROTECTION -L- STA. 159+30 TO 161+55 RT LINE WITH PSRM EST. 50 SY. MATTING SEE DETAIL 7E

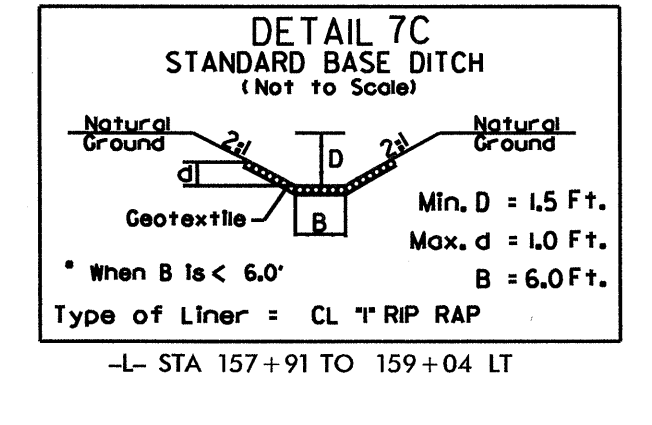
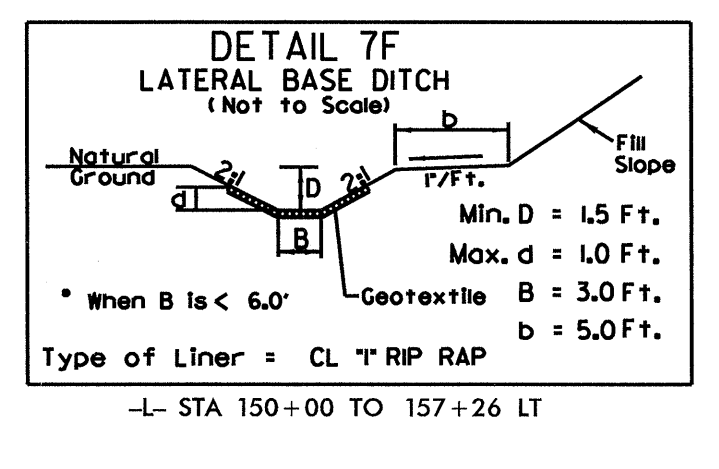
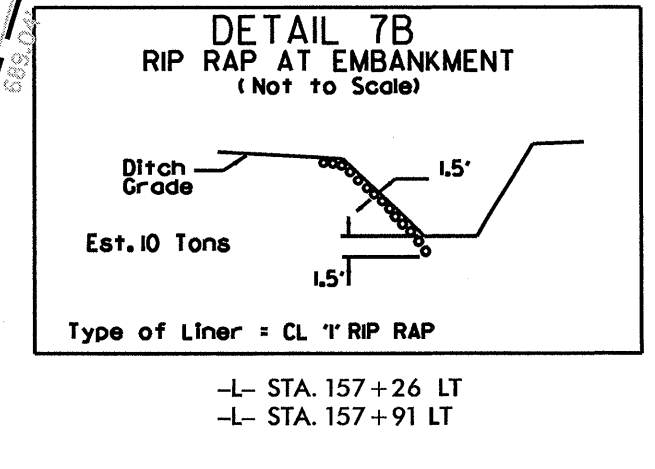
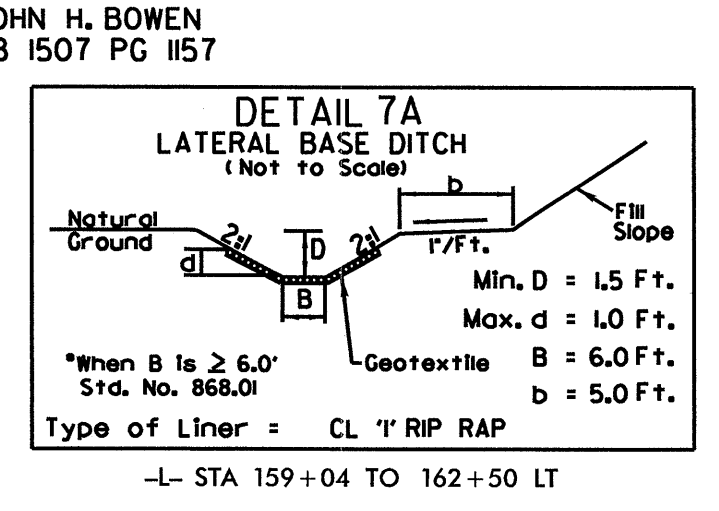
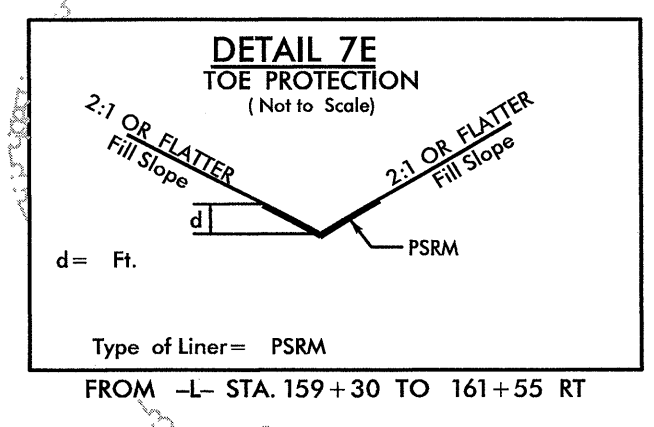
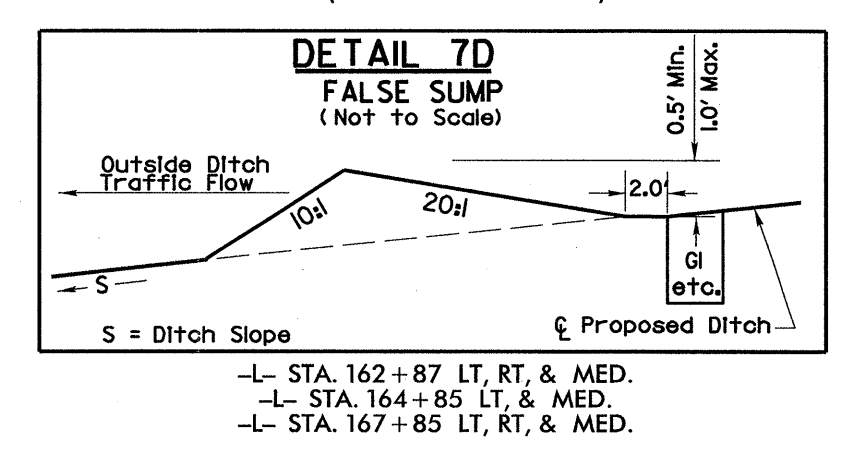

MARTHA BOWEN CROSBY and husband,
 G.C. CROSBY
 DB 18-Y PG 779
 DB 1213 PG 228

42
 JOHN H. BOWEN
 DB 1507 PG 1157

REVISIONS

ARCADIS C&M
 DATE: 04/13
 TIME: 01:00
 FILE: R-2707AB-7.dwg

SEE SHEETS 14 FOR -L- PROFILE
 SEE SHEETS S-1 THRU S-7 FOR
 STRUCTURE PLANS

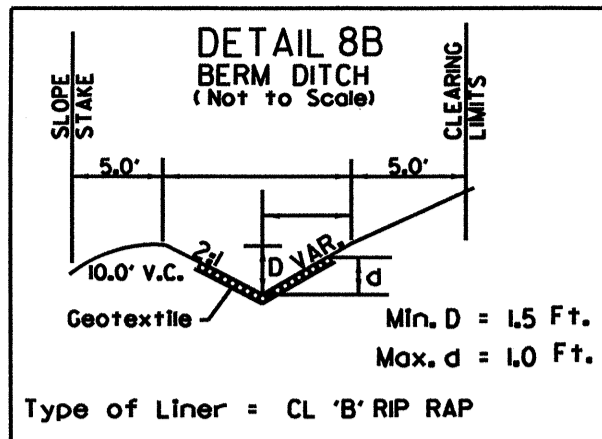
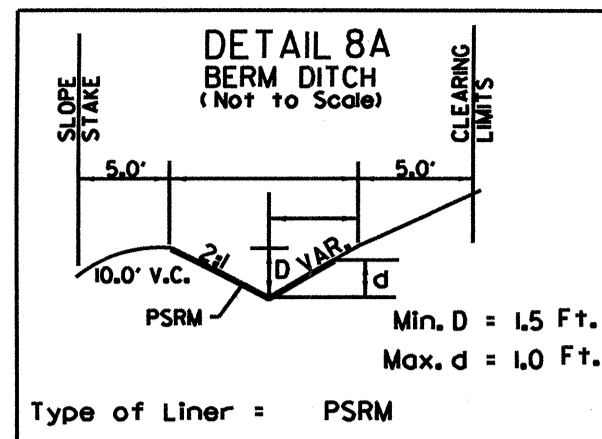

-L-
 PIs Sta 178+68.62
 Os = 1' 19" 20.0"
 Ls = 300.0'
 LT = 200.0'
 ST = 100.0'
 DS = 70 MPH
 e = .04

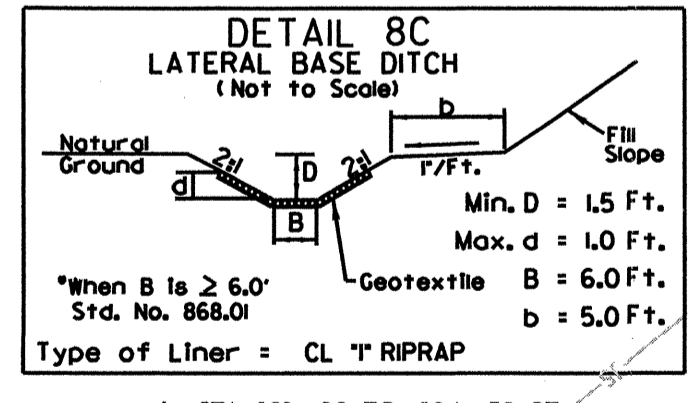
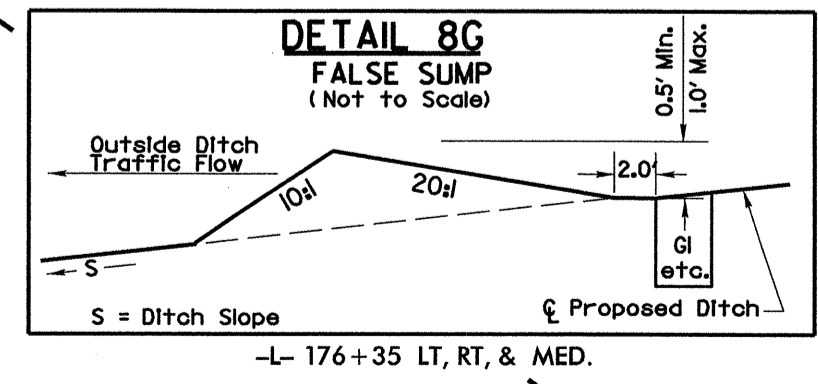
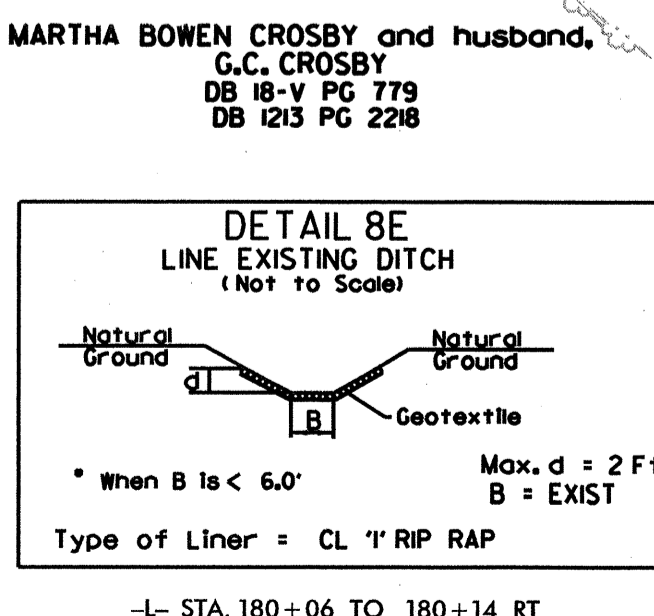
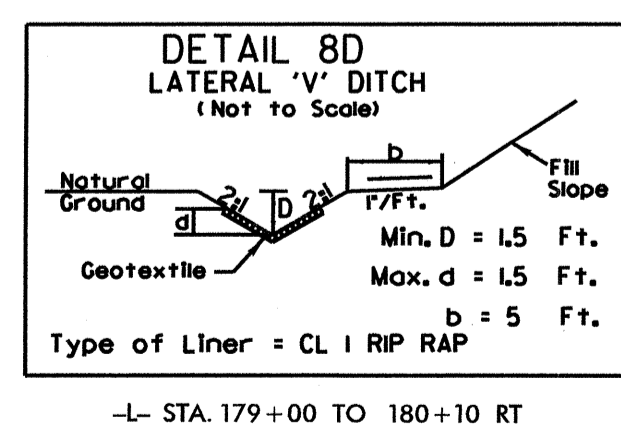
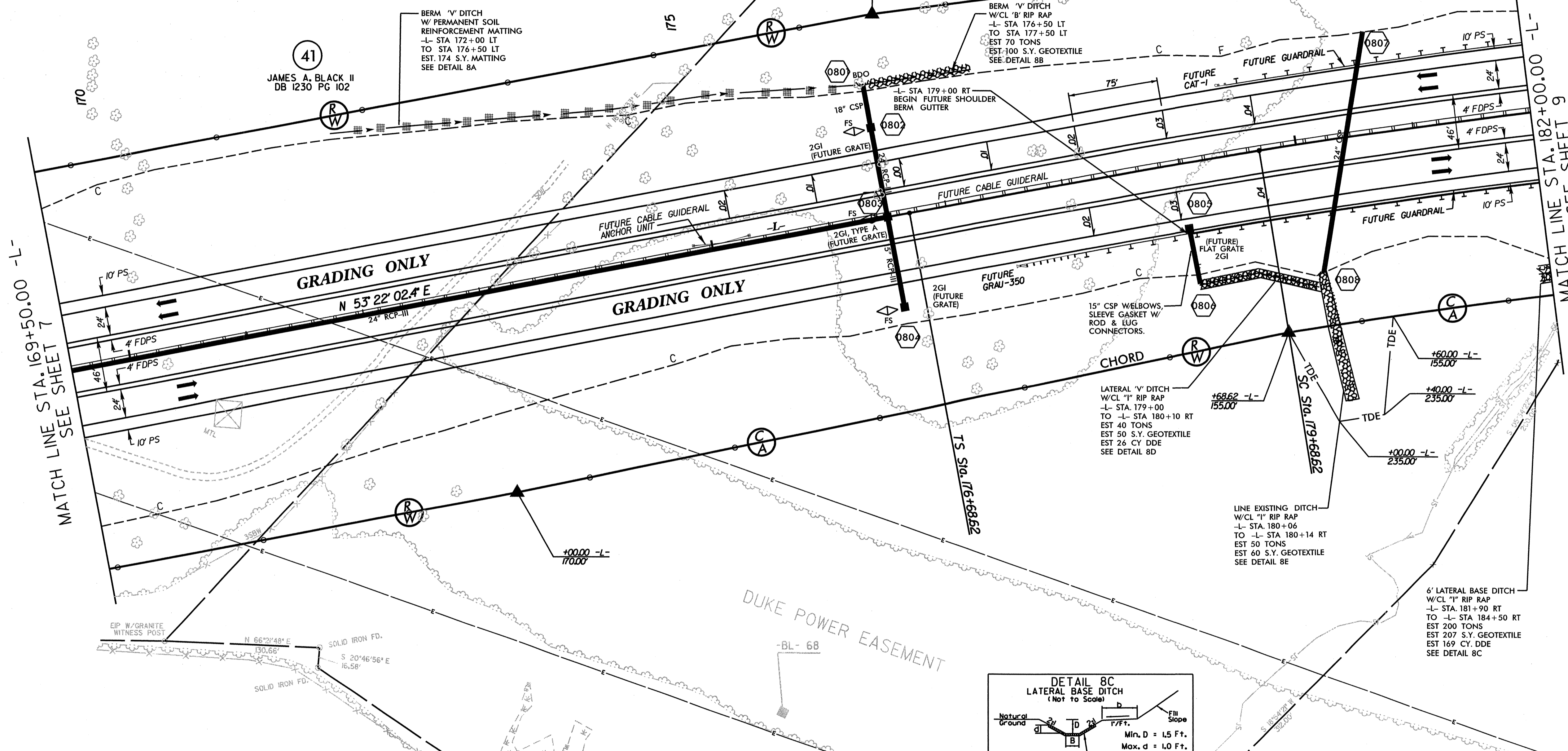

REVISIONS

ARCADIS G&M
 D:\rcas\2707AB\Drawings\DWG\DWG-08.dwg
 Time: 8:15 AM
 File Name: 2707AB-08.dwg

NC GRID NAD 8395

ARCADIS
 G. & M. of North Carolina, Inc.
 WWW.ARCADIS-US.COM
 801 Corporate Center Drive, Suite 300
 Raleigh, NC 27607-5073
 Tel: 919/854-1282 Fax: 919/854-5448 NC License No. C-1869

GREENHORNE & O'MARA
 CONSULTING ENGINEERS
 5565 CENTERVIEW DRIVE, SUITE 107
 RALEIGH, NC 27606
 (919) 851-1919 FAX (919) 851-8393
 LICENSE # F-0148

PROJECT REFERENCE NO. **R-2707AB** SHEET NO. **9**
 RW SHEET NO. **R-2707A 15**

ROADWAY DESIGN ENGINEER
 HYDRAULICS ENGINEER

SEAL 12786
 6.4.13

SEAL NOT VALID UNLESS SIGNED AND DATED

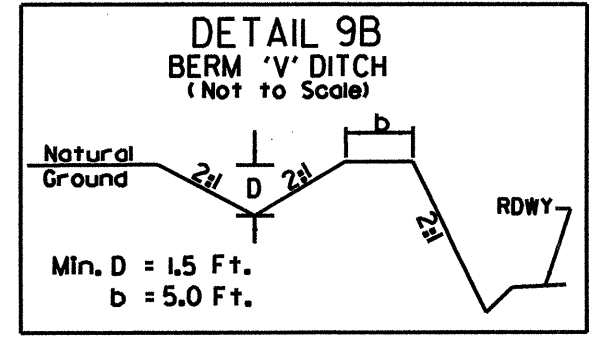

-L- STA 191+50 TO 193+50 LT
 -L- STA 193+50 TO 196+00 LT

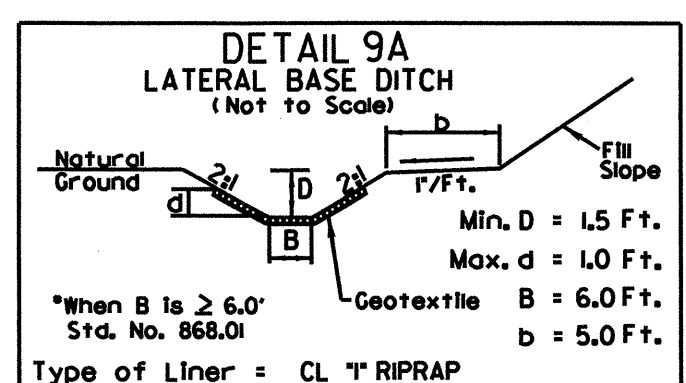

-L- STA 181+90 TO 184+50 RT

-L-
 PI Sta 189+39.81
 $\Delta = 16' 59" 45.3" (RT)$
 $D = 0' 52" 53.3"$
 $L = 1928.13'$
 $T = 971.20'$
 $R = 6,500.00'$
 $DS = 70 MPH$
 $e = .04$

BERM "V" DITCH
 -L- STA. 193+50 TO
 STA. 196+00 LT
 SEE DETAIL 9B

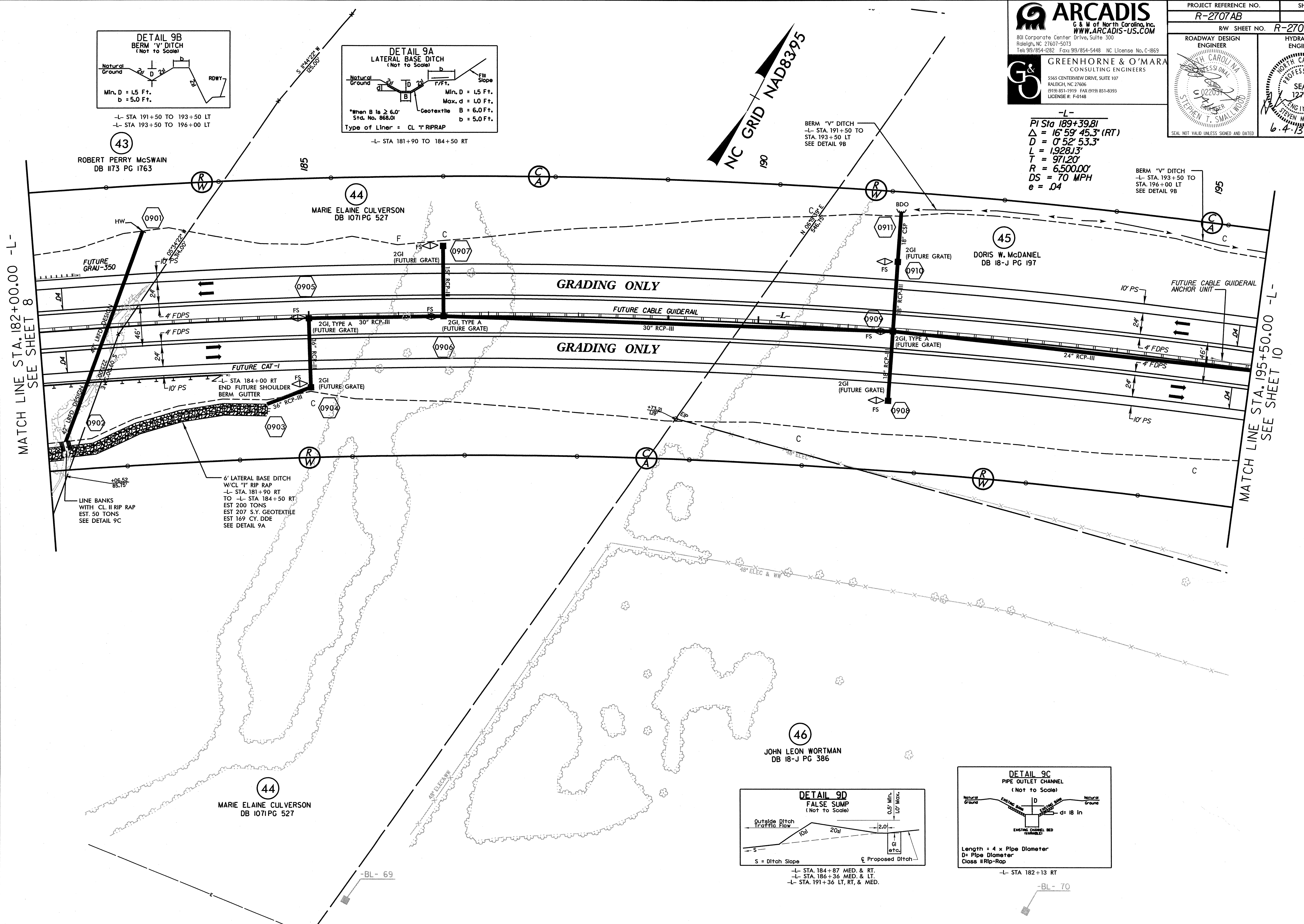

MATCH LINE STA. 182+00.00 -L-
 SEE SHEET 8

MATCH LINE STA. 195+50.00 -L-
 SEE SHEET 10

LINE BANKS WITH CL II RIP RAP EST. 50 TONS SEE DETAIL 9C

6' LATERAL BASE DITCH W/CL II RIP RAP
 -L- STA. 181+90 RT
 TO -L- STA. 184+50 RT
 EST 200 TONS S.Y. GEOTEXTILE
 EST 169 CY. DDE
 SEE DETAIL 9A

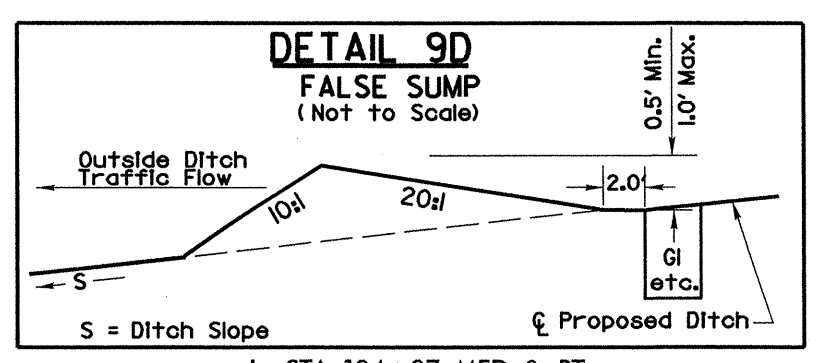

-L- STA. 184+87 MED. & RT.
 -L- STA. 186+36 MED. & LT.
 -L- STA. 191+36 LT, RT, & MED.

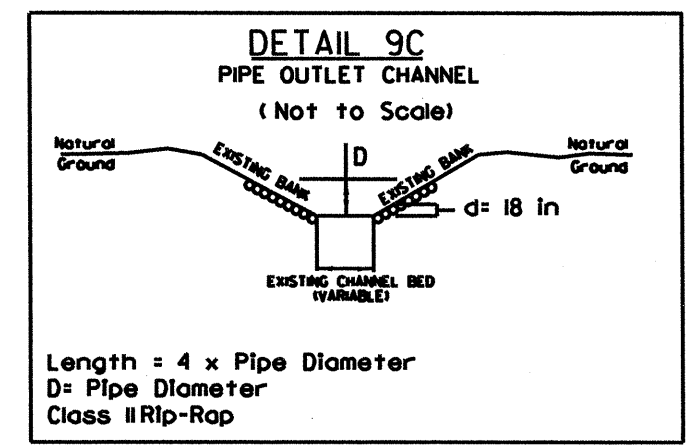

Length = 4 x Pipe Diameter
 D = Pipe Diameter
 Class II Rip-Rap
 -L- STA 182+13 RT

ARCADIS G&M
 Date: 6/13/13
 File Name: R-2707AB-15

SEE SHEETS 15 FOR -L- PROFILE

-L-
 PIs Sta 199+96.75
 Os = 1' 19" 20.0"
 Ls = 300.00'
 LT = 200.00'
 ST = 100.00'
 DS = 70 MPH
 e = .04

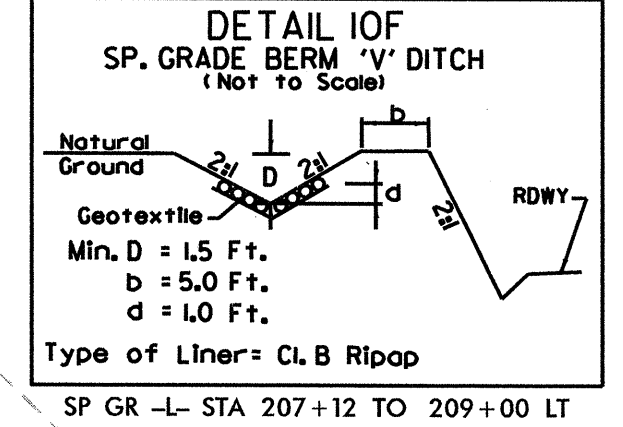
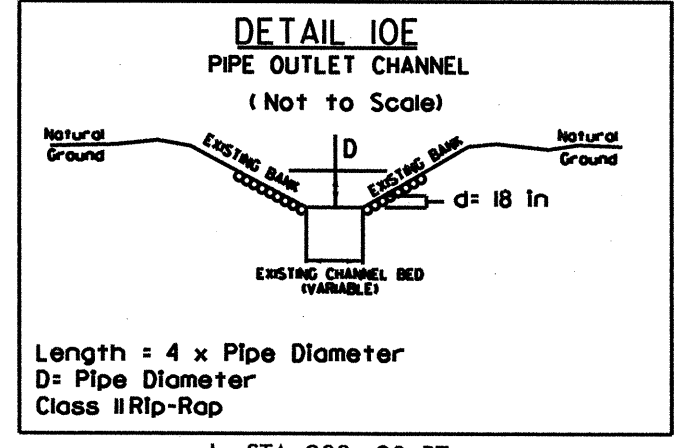
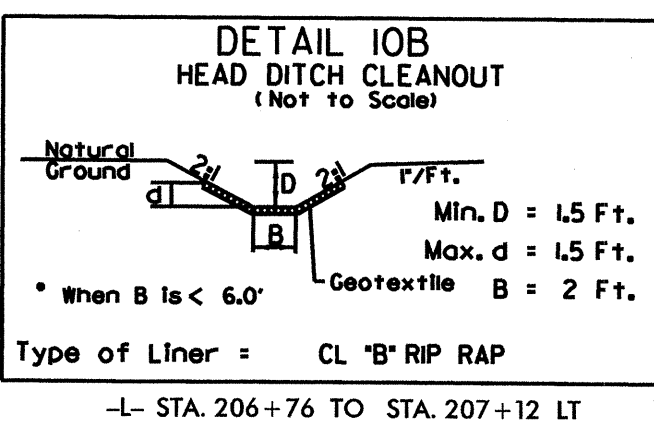
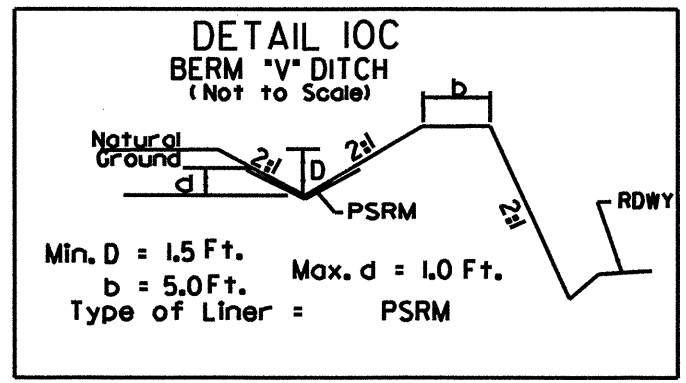
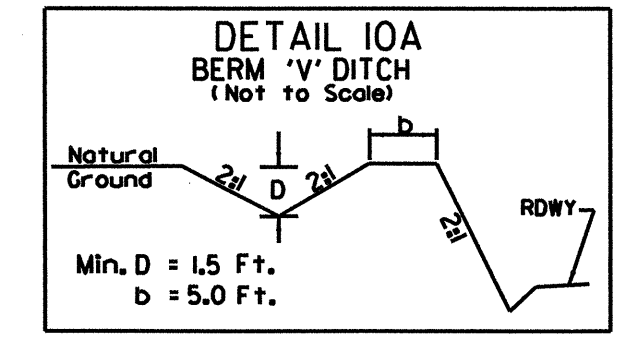
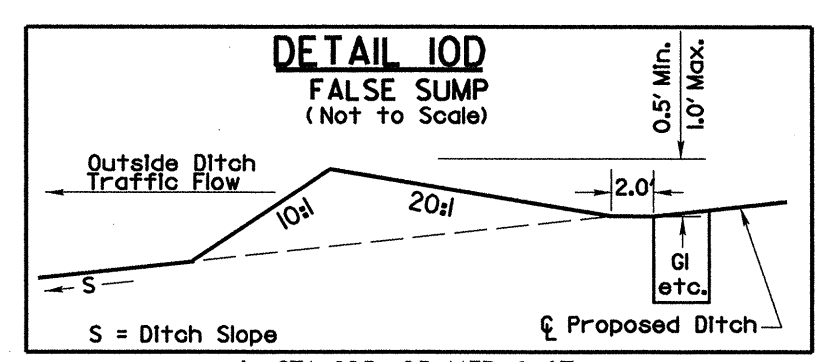
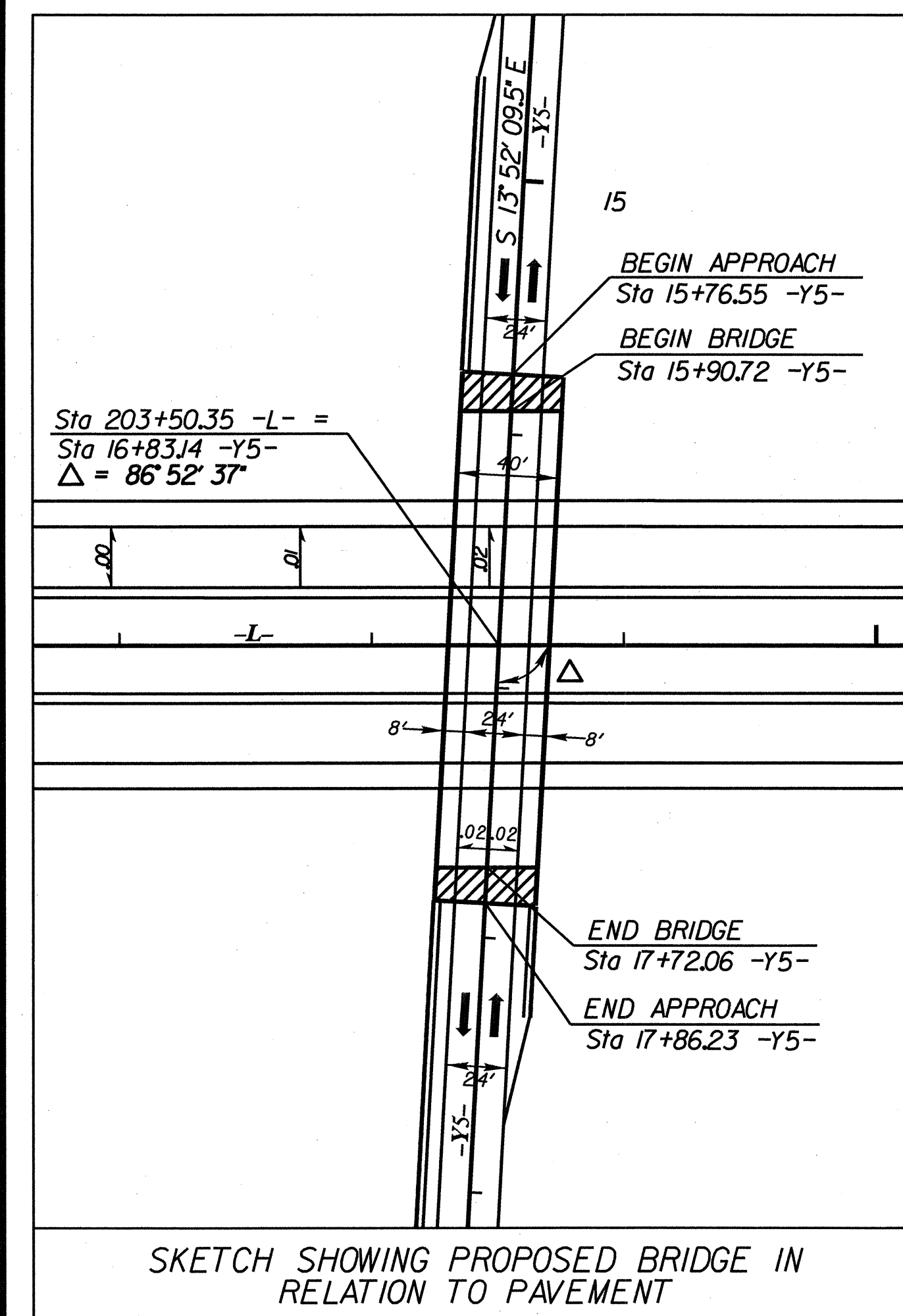

NC GRID NAD 8395

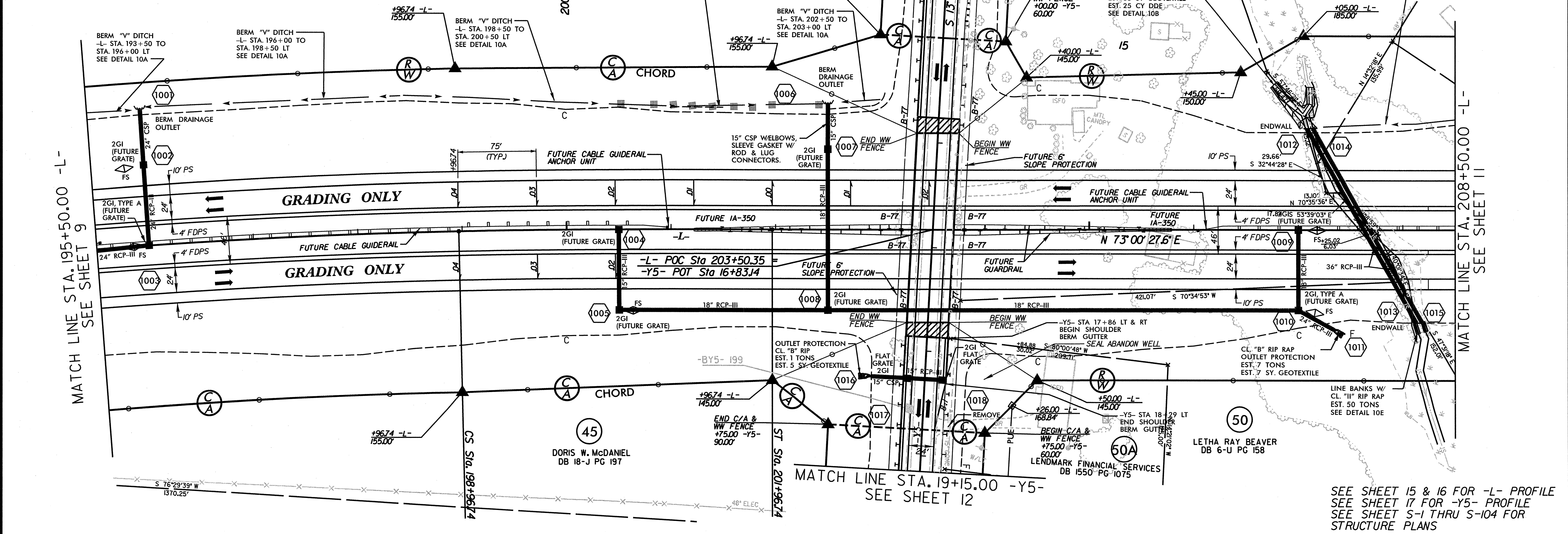

MATCH LINE STA. 195+50.00 -L-
 SEE SHEET 9

MATCH LINE STA. 208+50.00 -L-
 SEE SHEET 11

MATCH LINE STA. 19+50.00 -Y5-
 SEE SHEET 12

SEE SHEET 15 & 16 FOR -L- PROFILE
 SEE SHEET 17 FOR -Y5- PROFILE
 SEE SHEET S-1 THRU S-104 FOR
 STRUCTURE PLANS

REVISIONS

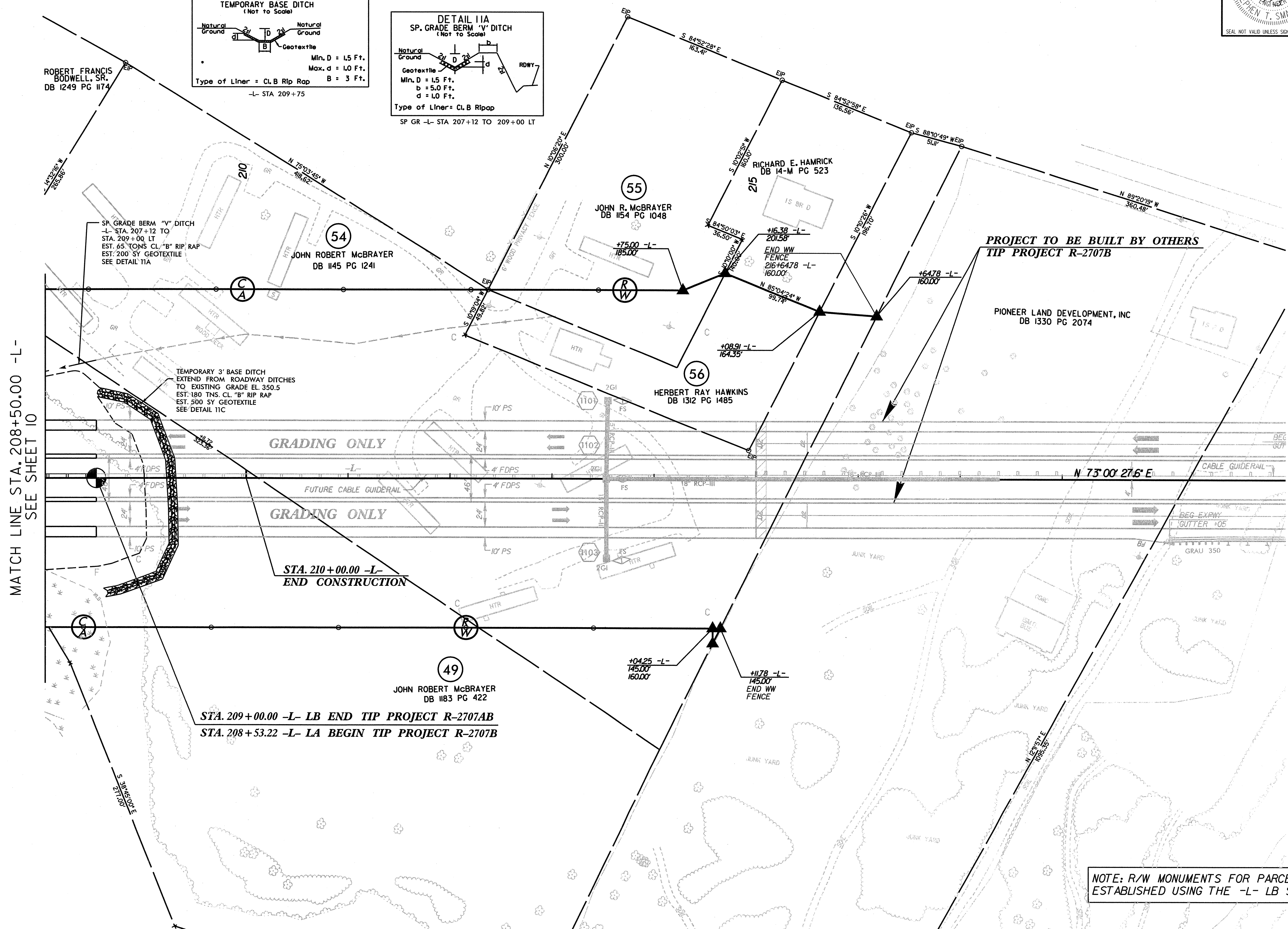
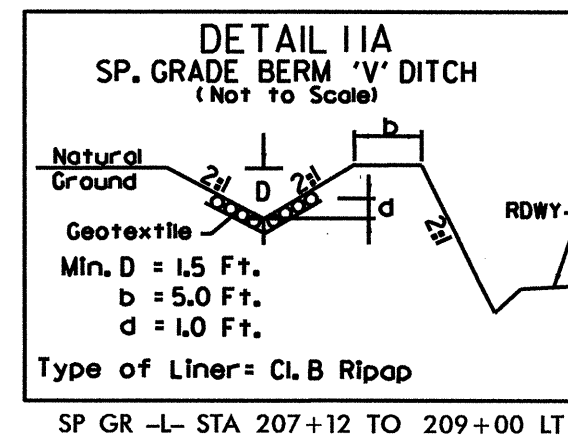
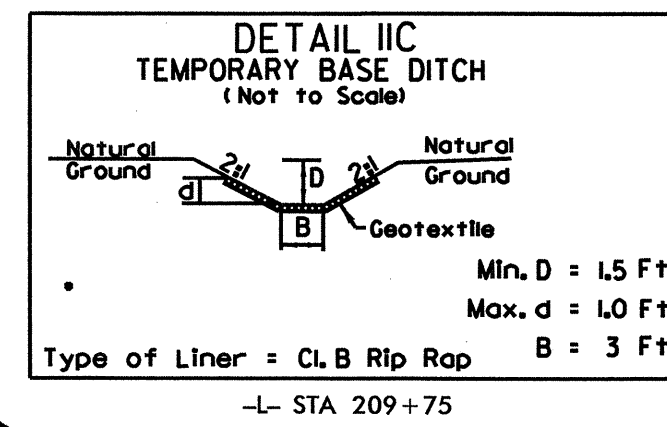
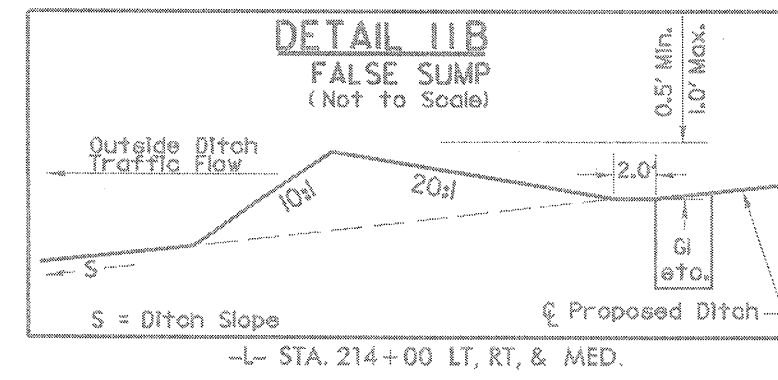

NC GRID NAD 8395

NOTE: R/W MONUMENTS FOR PARCELS 49, 55, & 56 WERE ESTABLISHED USING THE -L- LB STATIONING.

SEE SHEET 16 FOR -L- PROFILE

REVISIONS

ARCADIS G&M
 Date: 6/4/13
 Time: 4:15 PM
 File Name: R-2707AB

MATCH LINE STA. 19+5.00 -Y5-
 SEE SHEET 10

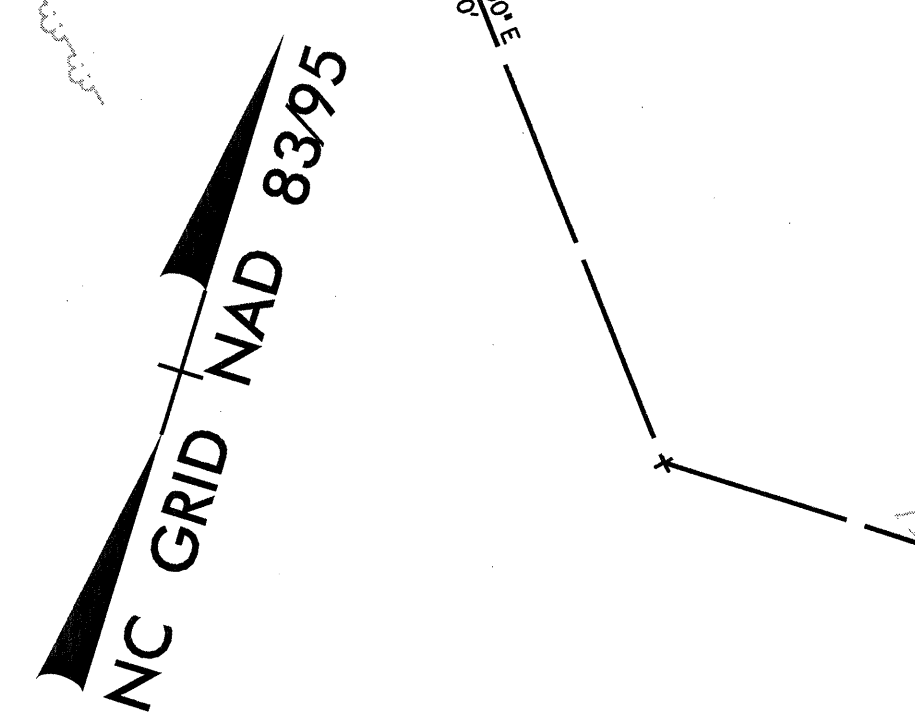
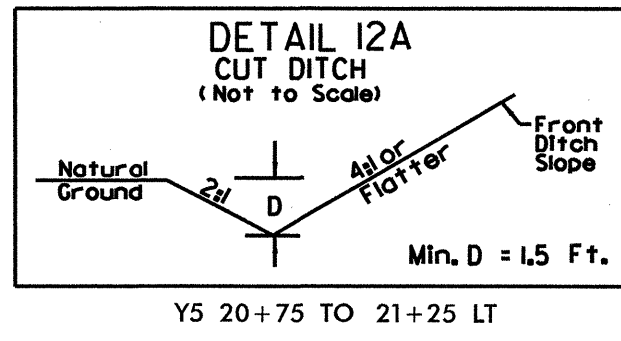
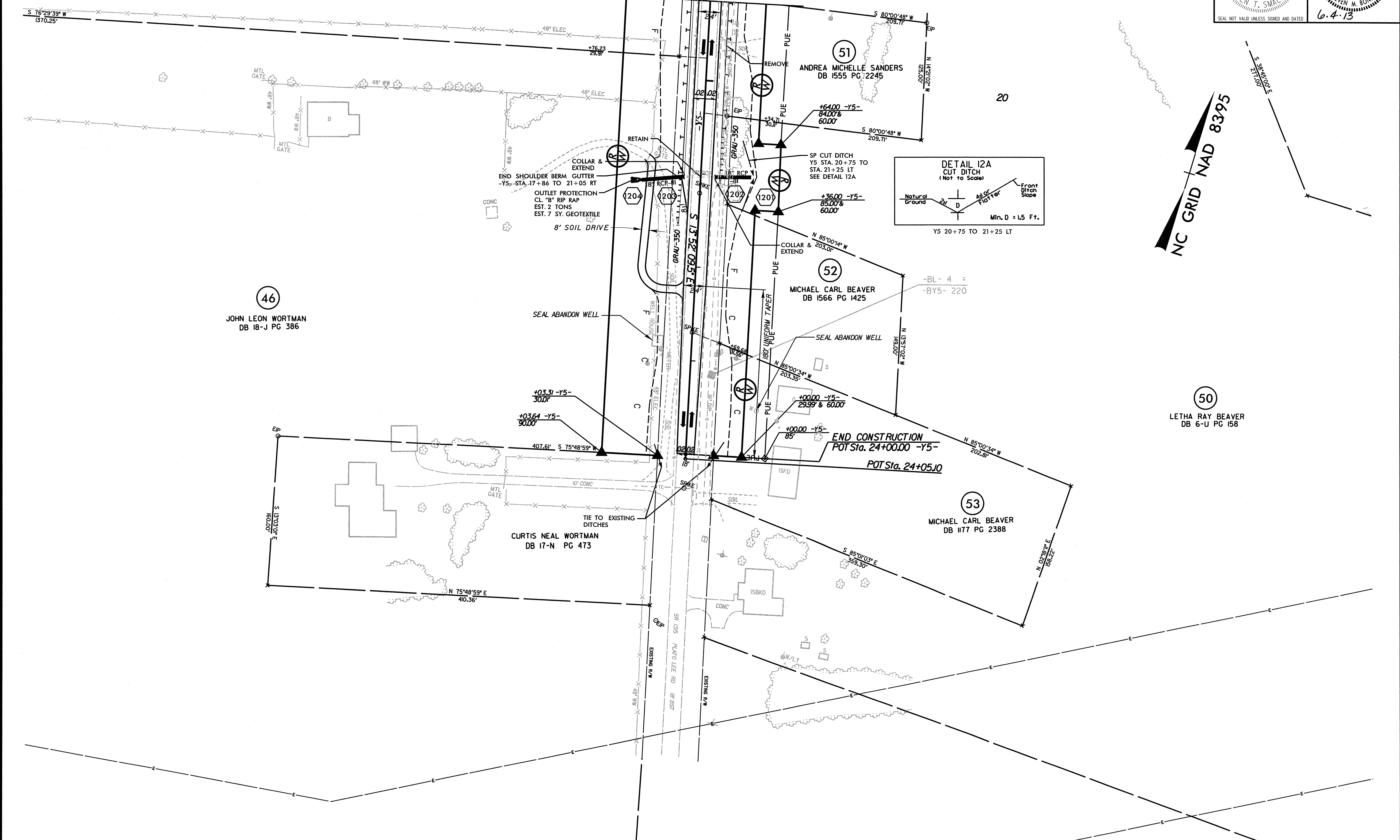

REVISIONS

ARCADIS GSM
 DATE: 6/4/13
 TIME: 10:00 AM
 FILENAME: R-2707AB

SEE SHEET 17 FOR -Y5- PROFILE

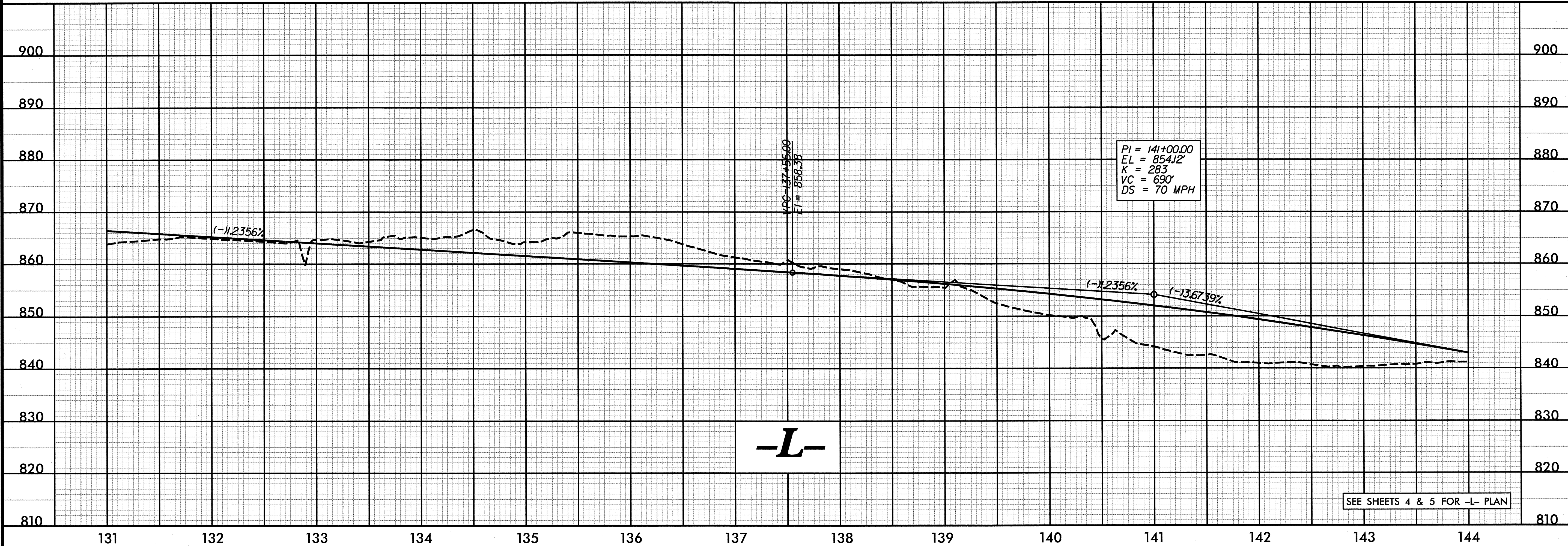
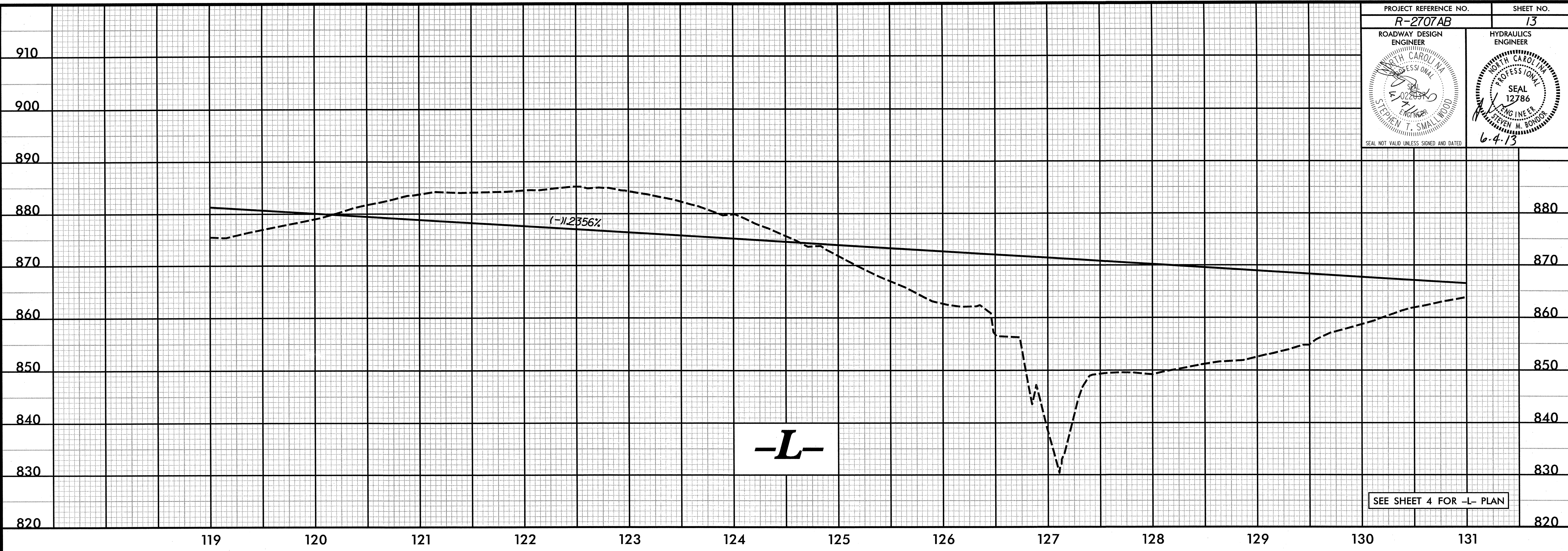

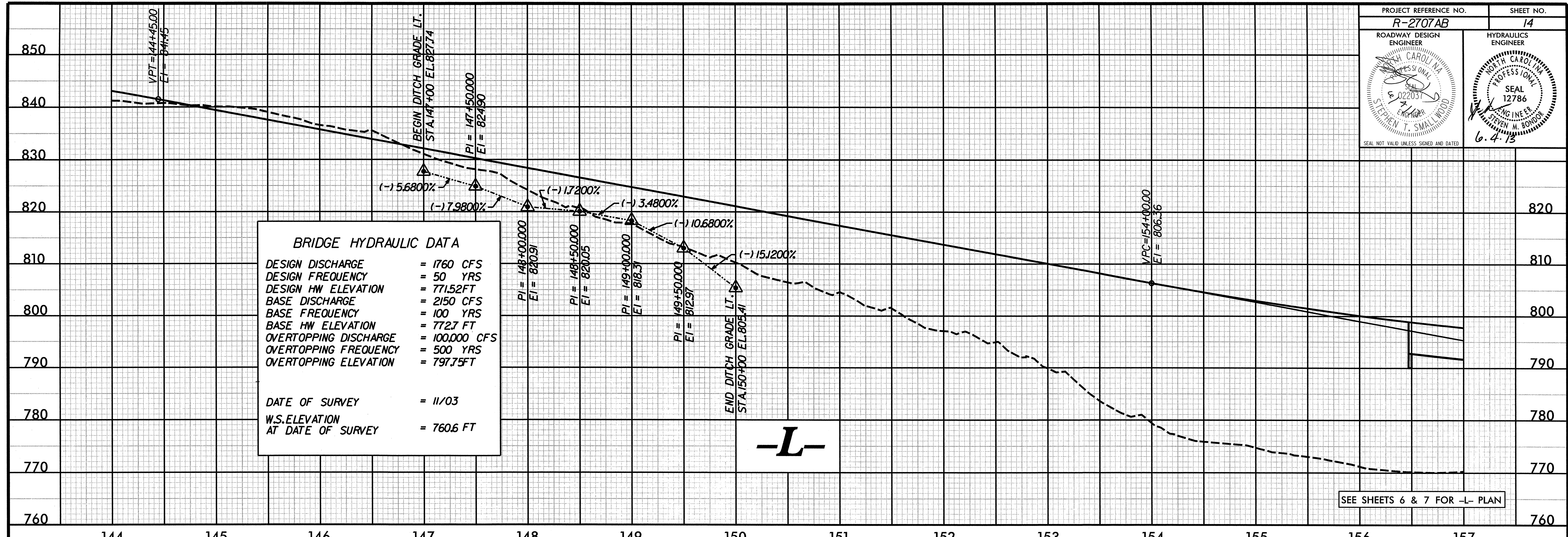

SEE SHEETS 6 & 7 FOR -L- PLAN

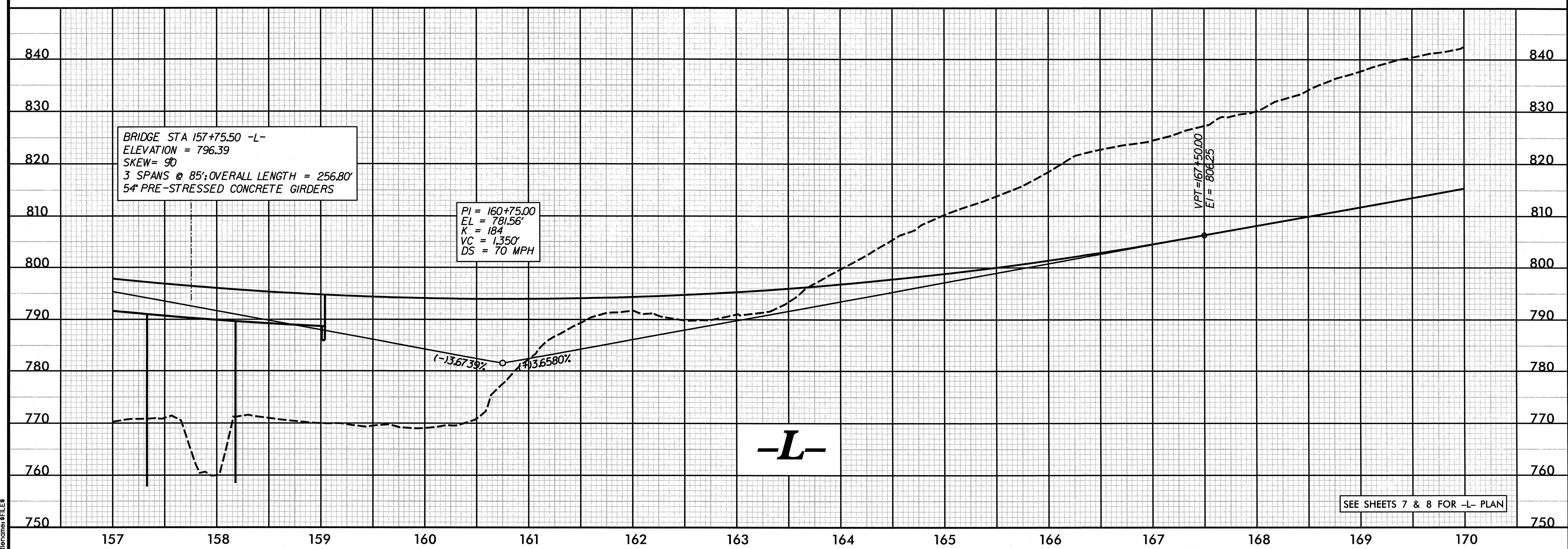

SEE SHEETS 7 & 8 FOR -L- PLAN

PIPE HYDRAULIC DATA	
DRAINAGE STRUCTURE NO.2	
DRAINAGE AREA	= 36 AC
DESIGN FREQUENCY	= 50 YRS
DESIGN DISCHARGE	= 55 CFS
DESIGN HW ELEVATION	= 822.0 FT
100 YEAR DISCHARGE	= 67 CFS
100 YEAR HW ELEVATION	= 822.5 FT
OVERTOPPING FREQUENCY	= 500 YRS
OVERTOPPING DISCHARGE	= 220 CFS
OVERTOPPING ELEVATION	= 837.0 FT

PI = 178+00.00
 EL = 844.66'
 K = 299
 VC = 710'
 DS = 70 MPH

PIPE HYDRAULIC DATA	
DRAINAGE STRUCTURE NO.1	
DRAINAGE AREA	= 6.5 AC
DESIGN FREQUENCY	= 50 YRS
DESIGN DISCHARGE	= 17 CFS
DESIGN HW ELEVATION	= 823.7 FT
100 YEAR DISCHARGE	= 18 CFS
100 YEAR HW ELEVATION	= 823.8 FT
OVERTOPPING FREQUENCY	= 500 YRS
OVERTOPPING DISCHARGE	= 63 CFS
OVERTOPPING ELEVATION	= 837 FT

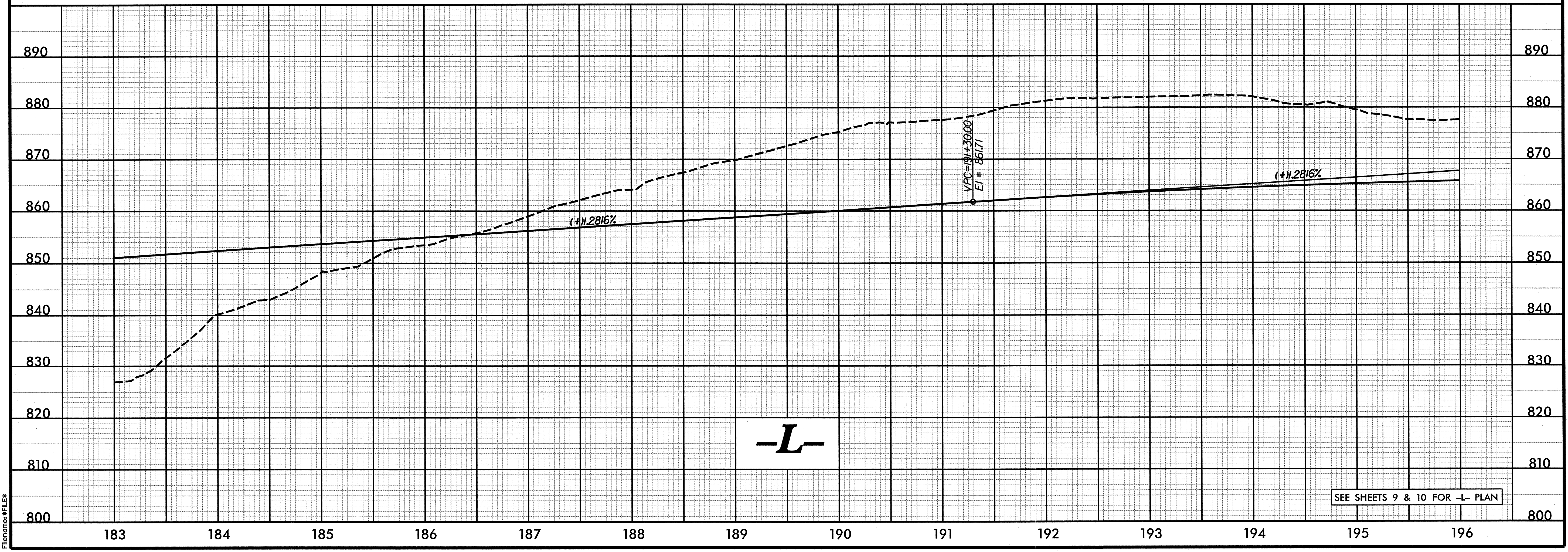
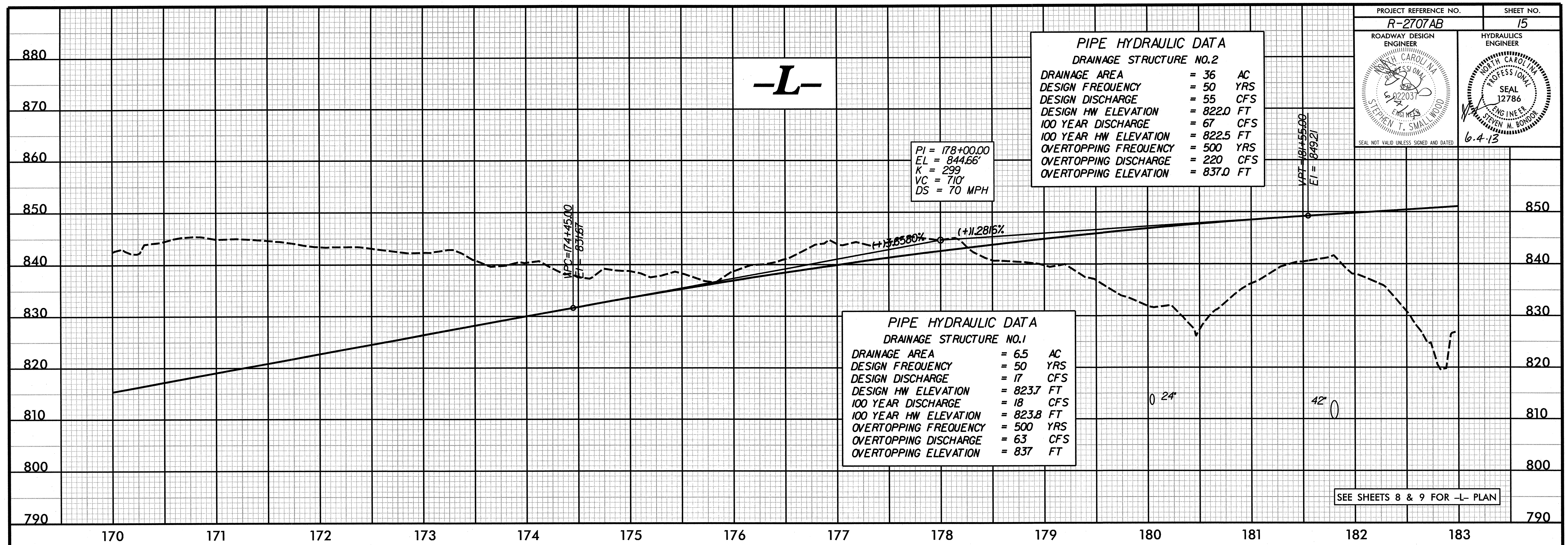

PIPE HYDRAULIC DATA DRAINAGE STRUCTURE NO.3	
DRAINAGE AREA	= 48 AC
DESIGN FREQUENCY	= 50 YRS
DESIGN DISCHARGE	= 65 CFS
DESIGN HW ELEVATION	= 855.2 FT
100 YEAR DISCHARGE	= 79 CFS
100 YEAR HW ELEVATION	= 855.5 FT
OVERTOPPING FREQUENCY	= 50 YRS
OVERTOPPING DISCHARGE	= 65 CFS
OVERTOPPING ELEVATION	= 855.3 FT

PI = 202+20.00
 EL = 875.68'
 K = 56.3
 VC = 2,180'
 DS = 70+ MPH

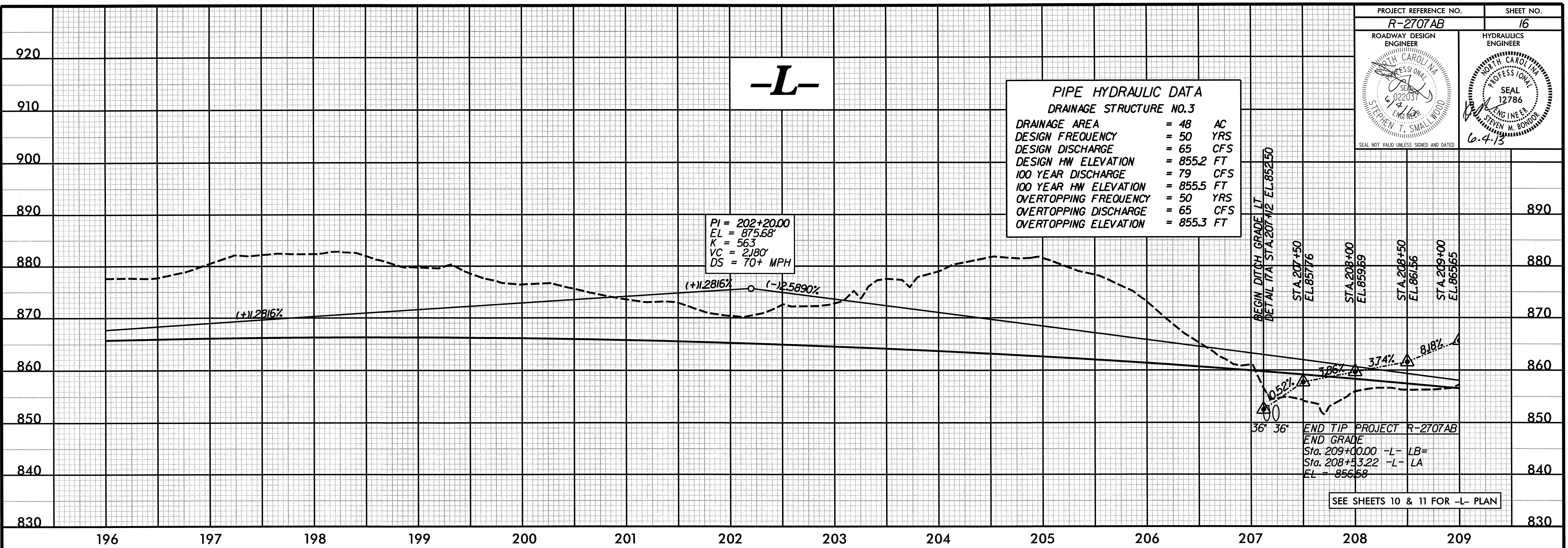

PIPE HYDRAULIC DATA
 DRAINAGE STRUCTURE NO.

DRAINAGE AREA	= 7	AC
DESIGN FREQUENCY	= 25	YRS
DESIGN DISCHARGE	= 18	CFS
DESIGN HW ELEVATION	= 887.7	FT
100 YEAR DISCHARGE	= 20	CFS
100 YEAR HW ELEVATION	= 888.0	FT
OVERTOPPING FREQUENCY	= 500	YRS
OVERTOPPING DISCHARGE	= 28	CFS
OVERTOPPING ELEVATION	= 889.0	FT

