

09/08/09

TIP PROJECT: I-5501

CONTRACT: C203530

STRUCTURES

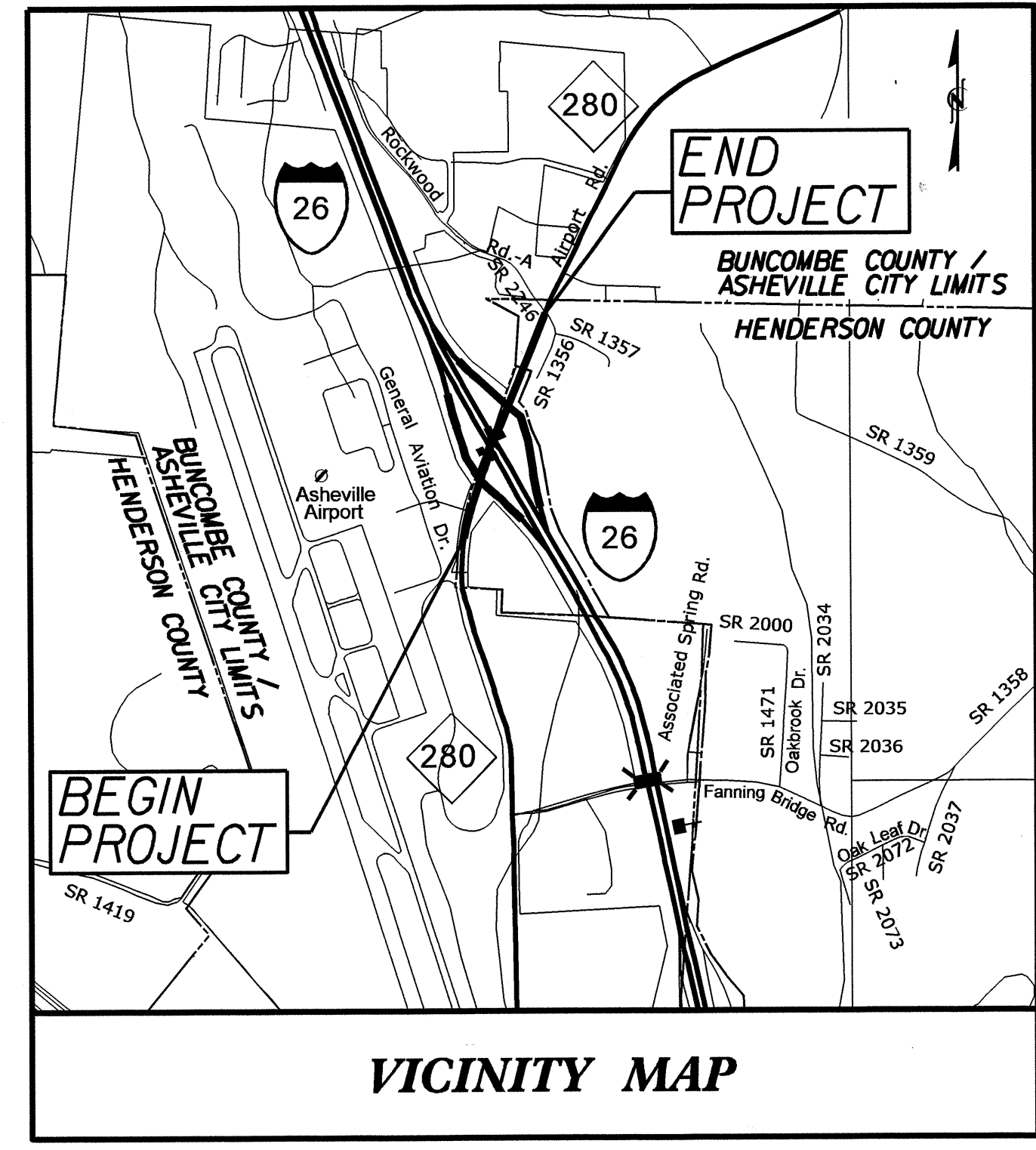

VICINITY MAP

STATE OF NORTH CAROLINA
DIVISION OF HIGHWAYS

BUNCOMBE & HENDERSON COUNTIES

LOCATION: I-26 / NC 280 INTERCHANGE IN ASHEVILLE
TYPE OF WORK: GRADING, PAVING, DRAINAGE, SIGNALS AND STRUCTURES

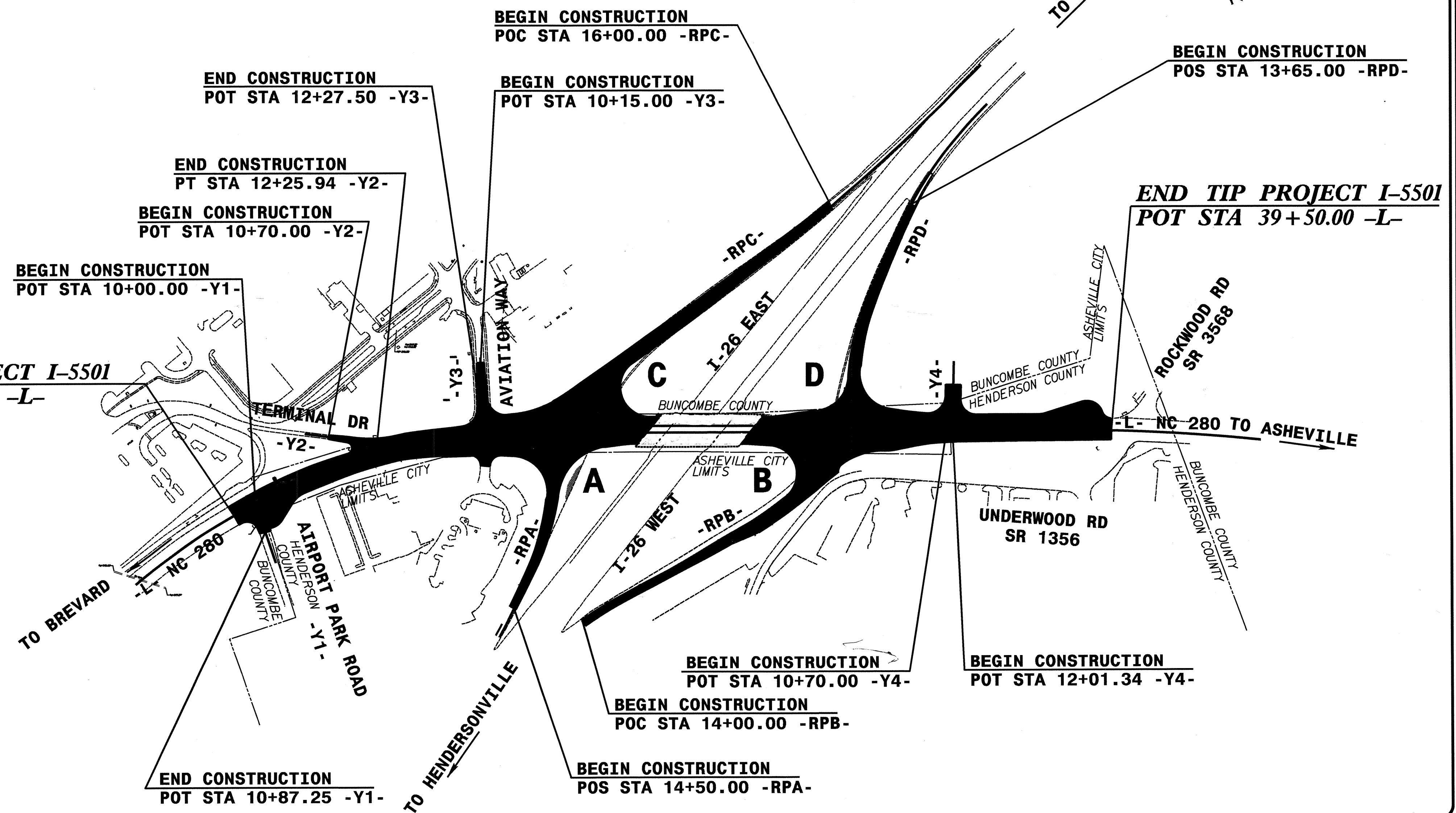

STATE	STATE PROJECT REFERENCE NO.	SHEET NO.	TOTAL SHEETS
N.C.	I-5501		
STATE PROJ. NO.	F.A. PROJ. NO.	DESCRIPTION	
46292.1.1	IMF-026-1(190)40	P.E.	
46292.2.1	IMF-026-1(190)40	ROW/UTIL	
46292.3. FS1	IMF-026-1(190)40	CONSTRUCTION	

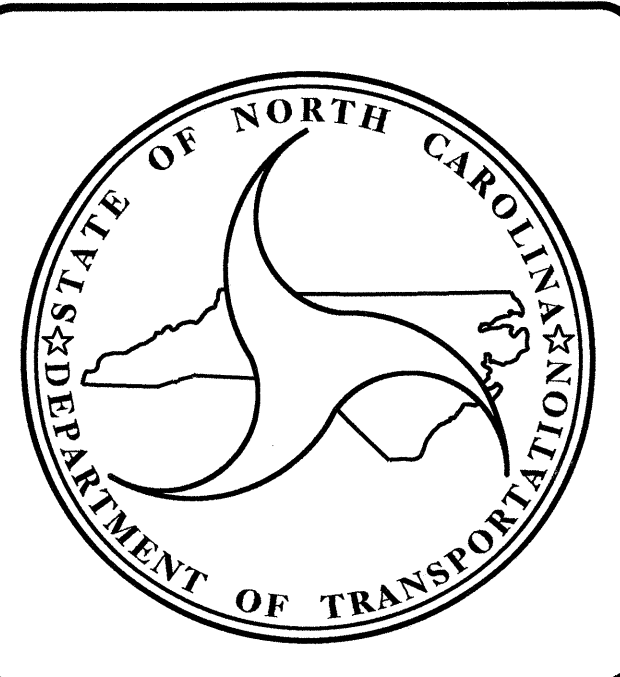
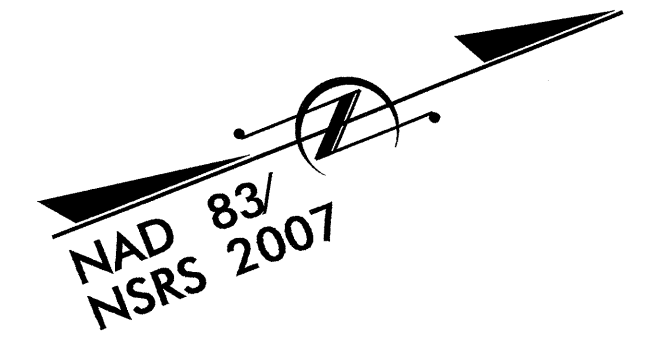

DESIGN DATA

ADT 2013 =	33,260
ADT 2033 =	36,845
DHV =	10 %
D =	55 %
T =	5 % *
V =	30 MPH
* TTST = 2% DUAL 3%	
FUNC CLASS = URBAN ARTERIAL	
STATEWIDE TIER	

PROJECT LENGTH

LENGTH ROADWAY TIP PROJECT I-5501 =	0.435 MILE
LENGTH STRUCTURE TIP PROJECT I-5501 =	0.057 MILE
TOTAL LENGTH TIP PROJECT I-5501 =	0.492 MILE

Prepared in the office of:
DIVISION OF HIGHWAYS

2012 STANDARD SPECIFICATIONS	
LETTING DATE: MARCH 18, 2014	Q. H. NGUYEN, P.E. PROJECT ENGINEER MARC G. CHEEK, P.E. PROJECT DESIGN ENGINEER

STRUCTURES MANAGEMENT UNIT
1000 BIRCH RIDGE DRIVE
RALEIGH, NC 27610

DIVISION OF HIGHWAYS
STATE OF NORTH CAROLINA

STATE DESIGN ENGINEER P.E.

DEPARTMENT OF TRANSPORTATION
FEDERAL HIGHWAY ADMINISTRATION

APPROVED P.E.
DIVISION ADMINISTRATOR

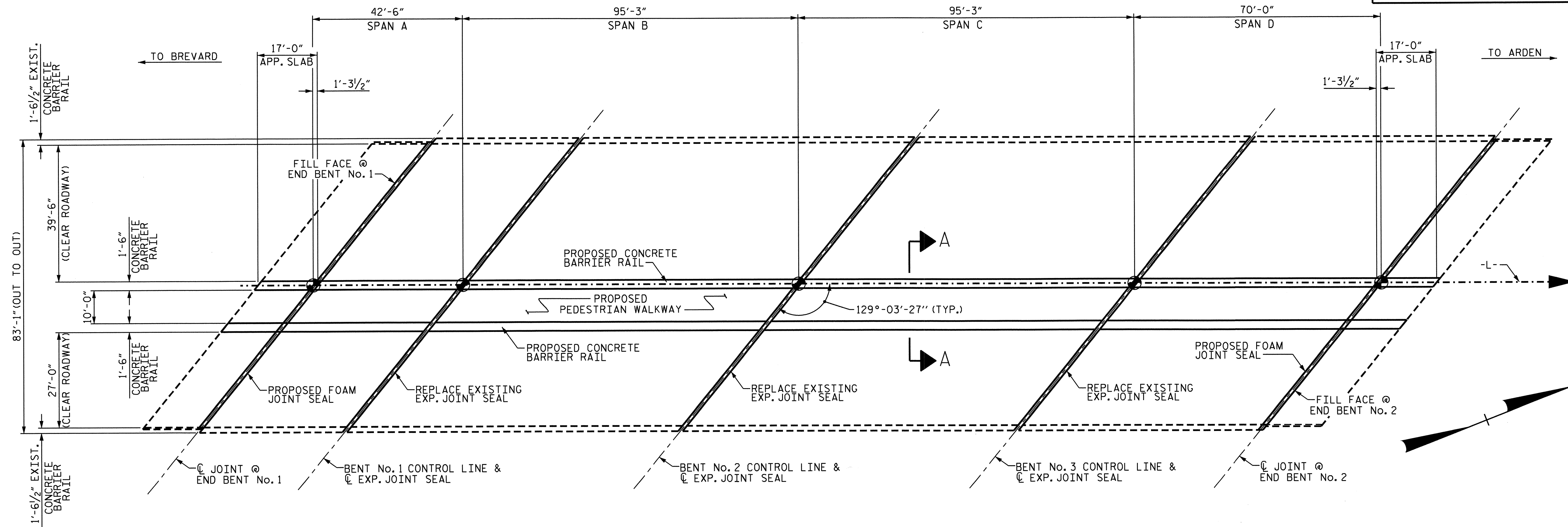

PLAN
FOR SECTION A-A AND LIMITS OF
HYDRODEMOLITION OF BRIDGE DECK, SEE SHEET 3 OF 7

TOTAL BILL OF MATERIAL				
CONCRETE BARRIER RAIL	FOAM JOINT SEALS	EXPANSION JOINT SEALS	SCARIFYING BRIDGE DECK	HYDRODEMOLITION OF BRIDGE DECK
LIN. FT.	LUMP SUM	LUMP SUM	SO. YDS.	SO. YDS.
668.63	LUMP SUM	LUMP SUM	186	186

NOTES

- FOR HYDRODEMOLITION OF BRIDGE DECK, SEE SPECIAL PROVISIONS.
- THE CONTRACTOR MUST COLLECT, TREAT AND DISPOSE OF RUN-OFF WATER FROM THE HYDRODEMOLITION PROCESS, SEE MANAGING HYDRODEMOLITION WATER SPECIAL PROVISION.
- FOR UNDER DECK CONTAINMENT, SEE HYDRODEMOLITION OF BRIDGE DECK SPECIAL PROVISION.
- FOR FALSEWORK AND FORMWORK, SEE SPECIAL PROVISIONS.
- FOR SUBMITTAL OF WORKING DRAWINGS, SEE SPECIAL PROVISIONS.
- FOR CRANE SAFETY, SEE SPECIAL PROVISIONS.
- FOR GROUT FOR STRUCTURES, SEE SPECIAL PROVISIONS.
- FOR MAINTENANCE AND PROTECTION OF TRAFFIC BENEATH PROPOSED STRUCTURE, SEE SPECIAL PROVISIONS.
- THE CONTRACTOR SHALL PROVIDE INDEPENDENT ASSURANCE SAMPLES OF REINFORCING STEEL AS FOLLOWS: FOR PROJECTS REQUIRING UP TO 400 TONS OF REINFORCING STEEL, ONE 30 INCH SAMPLE OF EACH SIZE BAR USED, AND FOR PROJECTS REQUIRING OVER 400 TONS OF REINFORCING STEEL, TWO 30 INCH SAMPLES OF EACH SIZE BAR USED. THE BARS FROM WHICH THE SAMPLES ARE TAKEN MUST THEN BE SPLICED WITH REPLACEMENT BARS OF THE SIZE AND LENGTH OF THE SAMPLE, PLUS A MINIMUM LAP SPLICE OF THIRTY BAR DIAMETERS. PAYMENT FOR THE SAMPLES OF REINFORCING STEEL SHALL BE CONSIDERED INCIDENTAL TO VARIOUS PAY ITEMS.

SCOPE OF WORK

- REMOVE EXISTING CONCRETE IN BRIDGE DECK AND APPROACH SLABS TO THE LIMITS SHOWN ON SHEET S-3 BY USING HYDRODEMOLITION PROCESS AND CONSTRUCT THE PROPOSED CONCRETE BARRIER RAILS, SEE SPECIAL PROVISIONS FOR "HYDRODEMOLITION OF BRIDGE DECK" AND "MANAGING HYDRODEMOLITION WATER".
- REPLACE THE EXISTING GLANDS OF EXISTING EXPANSION JOINT SEALS AND CLEAN AND PAINT EXISTING HOLD-DOWN PLATES AT BENTS NO. 1, 2 & 3. SEE SPECIAL PROVISIONS FOR "EXPANSION JOINT ELASTOMERIC SEAL REPLACEMENT".
- REMOVE EXISTING COMPRESSION JOINT SEALS, REMOVE EXISTING CONCRETE IN BRIDGE DECK AND APPROACH SLABS TO LIMITS SHOWN ON SHEET S-7 AND PLACE ELASTOMERIC CONCRETE HEADERS, AND INSTALL FOAM JOINT SEALS AT END BENT NO. 1 AND 2. SEE SPECIAL PROVISIONS FOR "FOAM JOINT SEAL REPLACEMENT", "BRIDGE JOINT DEMOLITION", AND "ELASTOMERIC CONCRETE".

PROJECT NO. I-5501
HENDERSON COUNTY
STATION: 25+83.78 -L-

SHEET 1 OF 7 BRIDGE No. 240

STATE OF NORTH CAROLINA
DEPARTMENT OF TRANSPORTATION
RALEIGH

PLAN VIEW
BRIDGE No. 240 ON
NC 280 OVER I-26

REVISIONS						SHEET NO.
NO.	BY:	DATE:	NO.	BY:	DATE:	S-1
1			3			TOTAL SHEETS 7
2			4			

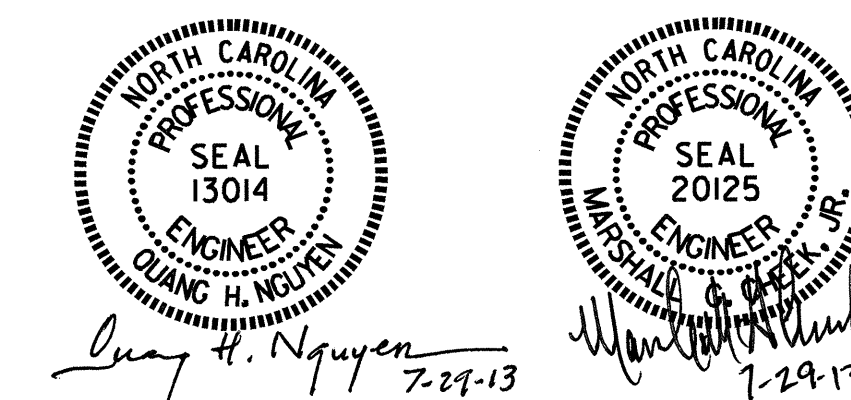

DRAWN BY: W.J. HARRIS DATE: 3/20/13
CHECKED BY: M.G. CHEEK DATE: 5/13

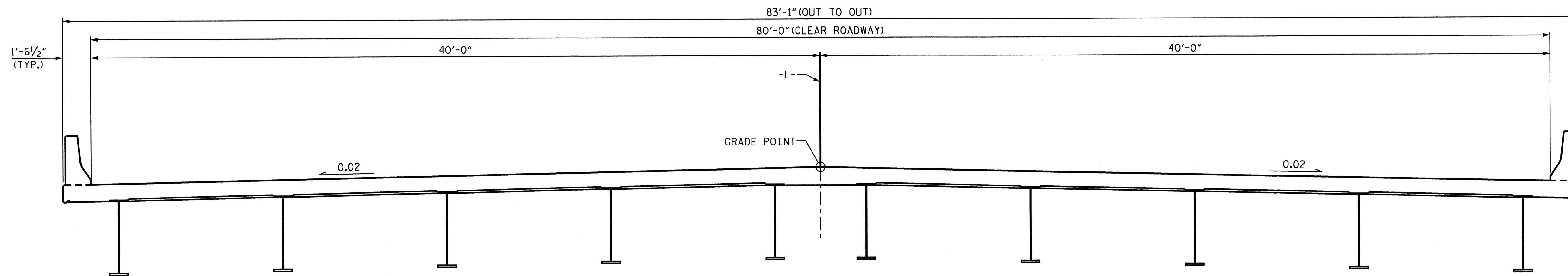

EXISTING TYPICAL SECTION

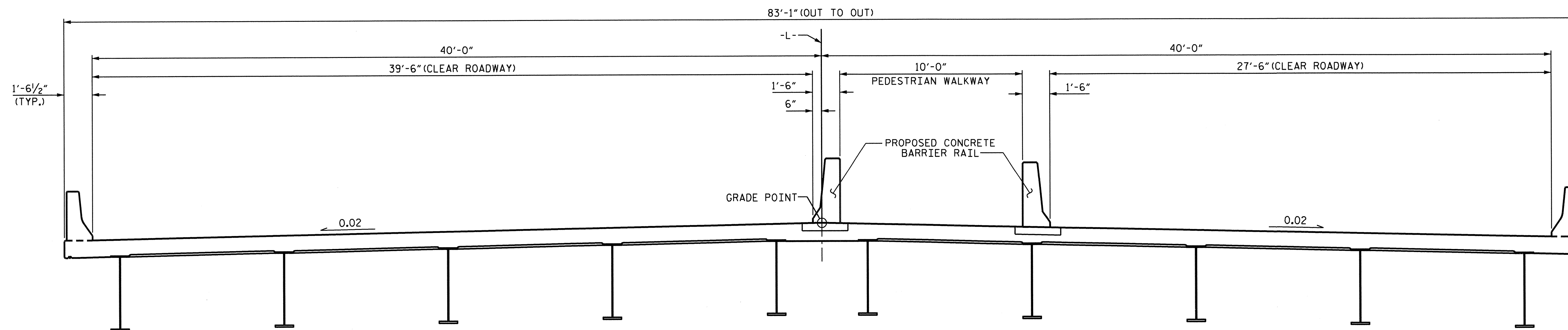

PROPOSED TYPICAL SECTION

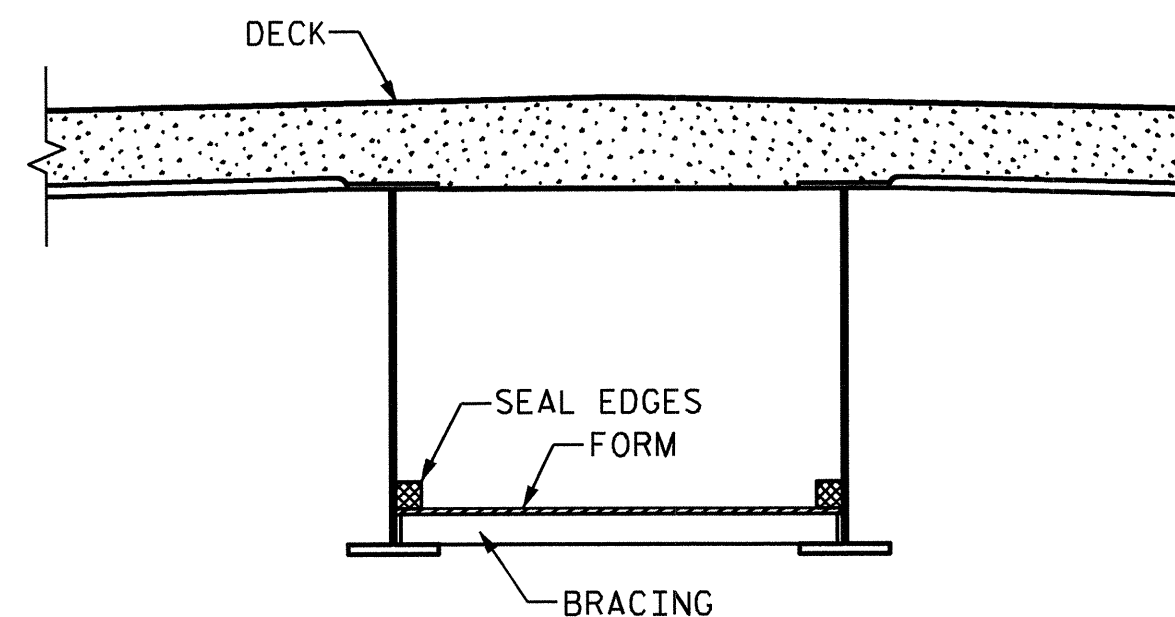

TYP. UNDER DECK CONTAINMENT AND FORMWORK

A METHOD TO CAPTURE WATER AND DEBRIS FROM BLOW THRU DURING HYDRODEMOLITION SHALL BE INSTALLED.
 SUBMIT DETAILS OF PROPOSED FORM WORK FOR APPROVAL PRIOR TO BEGINNING WORK.
 COST FOR INSTALLING AND REMOVING FORM WORK SHALL BE INCIDENTAL TO THE PRICE PER SQ. YARD OF HYDRODEMOLITION OF BRIDGE DECK.

PROJECT NO. I-5501
HENDERSON COUNTY
 STATION: 25+83.78 -L-

SHEET 2 OF 7

STATE OF NORTH CAROLINA
 DEPARTMENT OF TRANSPORTATION
 RALEIGH
 TYPICAL SECTION
 BRIDGE No.240 ON
 NC 280 OVER I-26

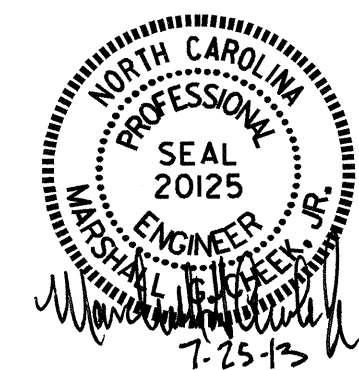

REVISIONS						SHEET NO.
NO.	BY:	DATE:	NO.	BY:	DATE:	S-2
1			3			TOTAL SHEETS
2			4			7

DRAWN BY : W.J. HARRIS DATE : 3/20/13
 CHECKED BY : M.G. CHEEK DATE : 5/13

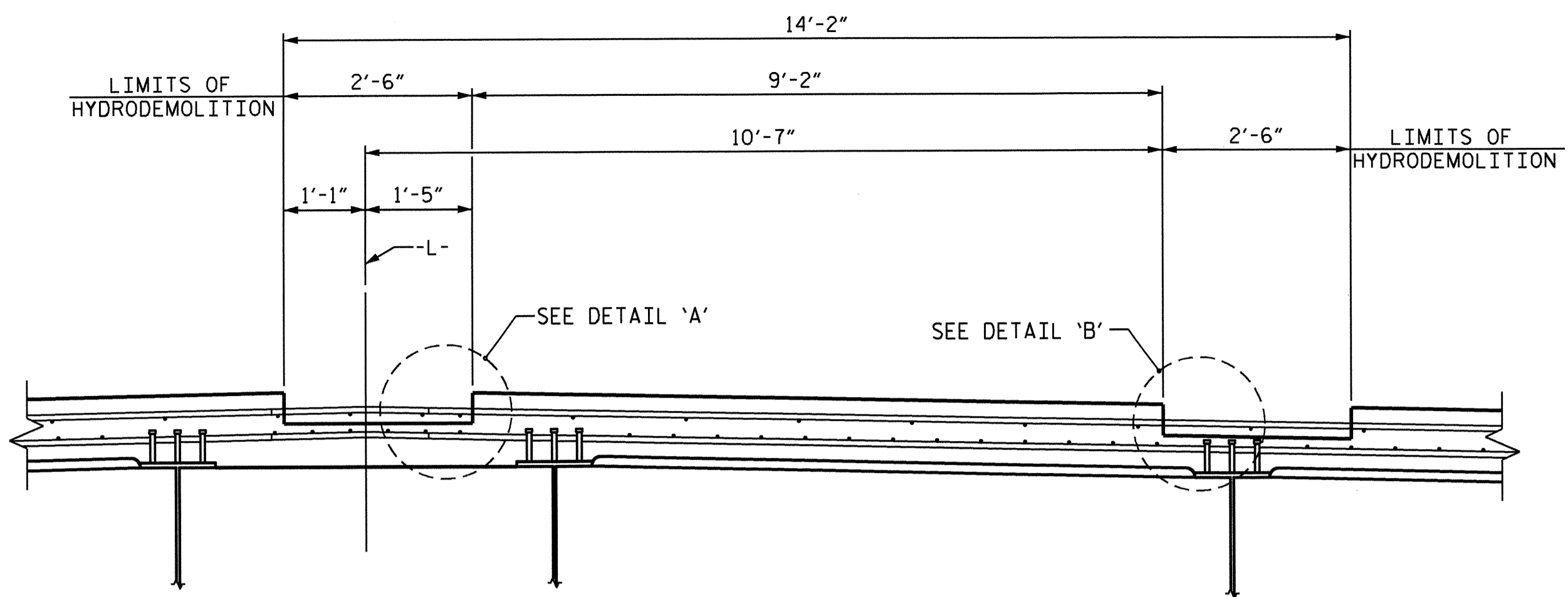

SECTION A-A

(PROPOSED)
(SHOWING BRIDGE DECK, APPROACH SLABS SIMILAR)

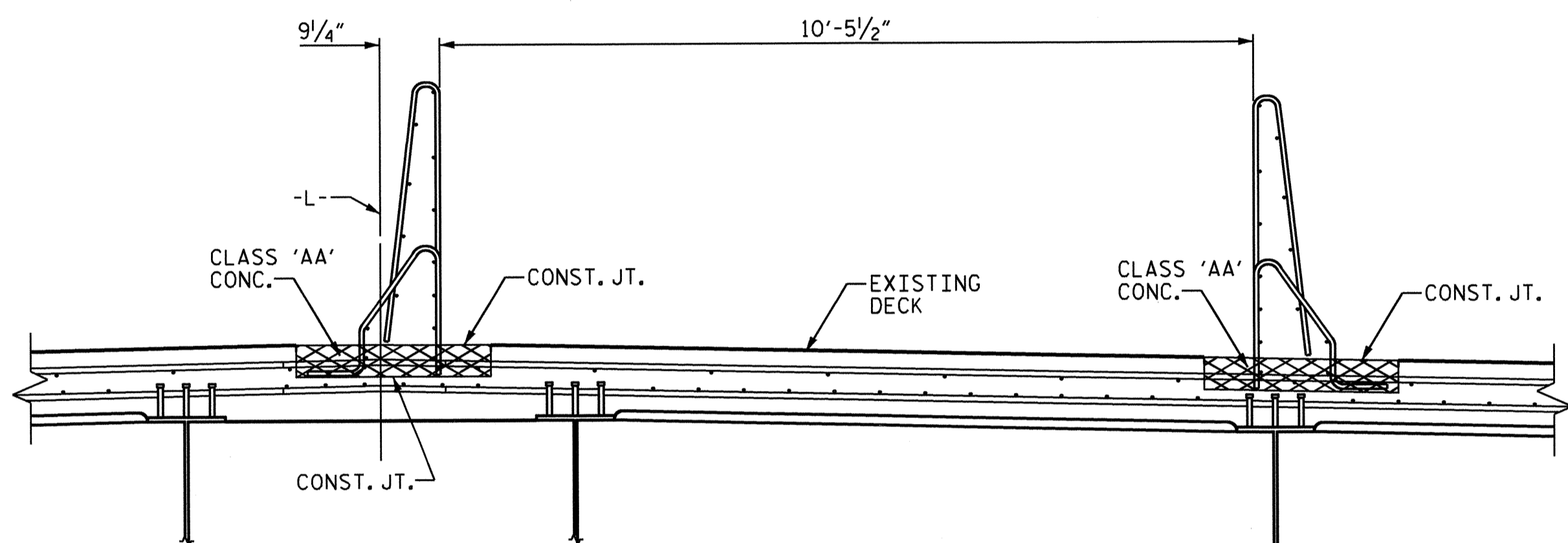

SECTION A-A

(PROPOSED)
(SHOWING BRIDGE DECK, APPROACH SLABS SIMILAR)

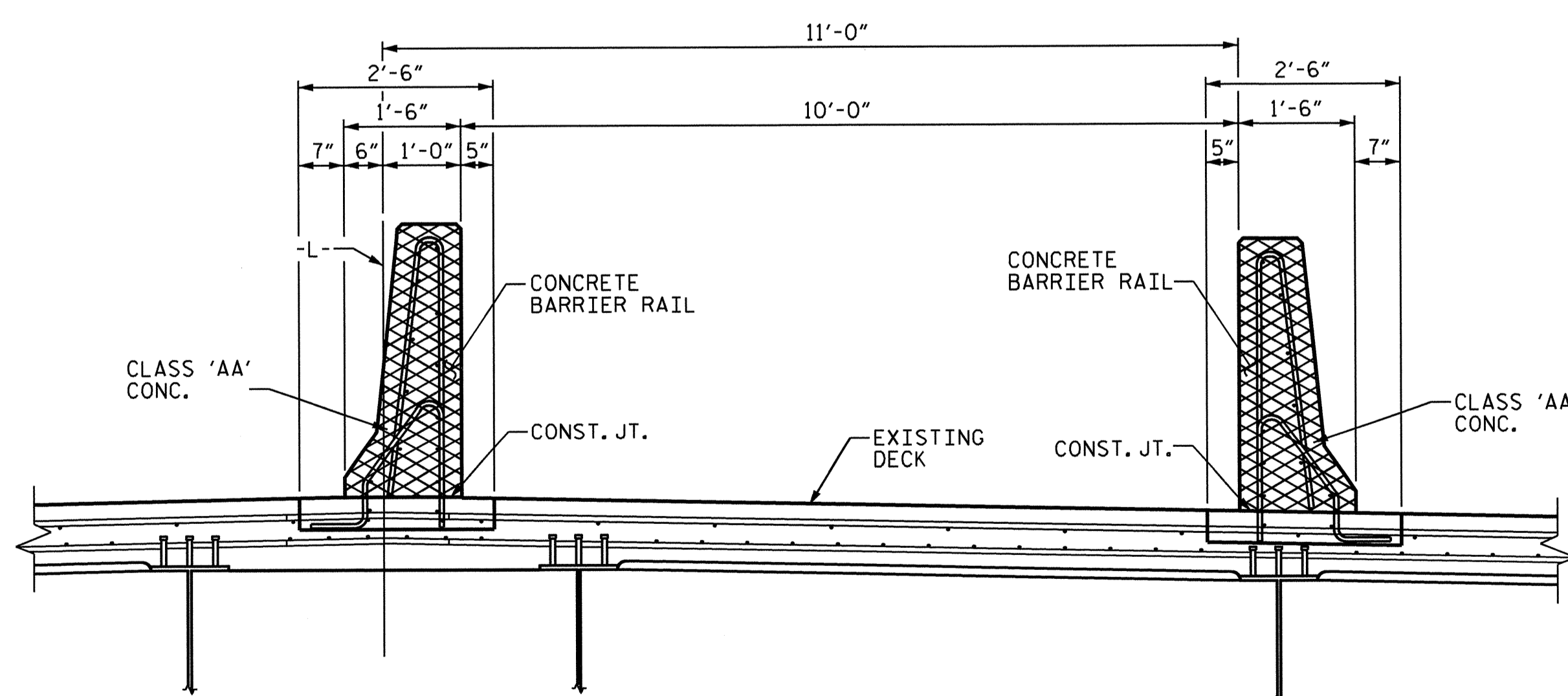

SECTION A-A

(PROPOSED)
(SHOWING BRIDGE DECK, APPROACH SLABS SIMILAR)

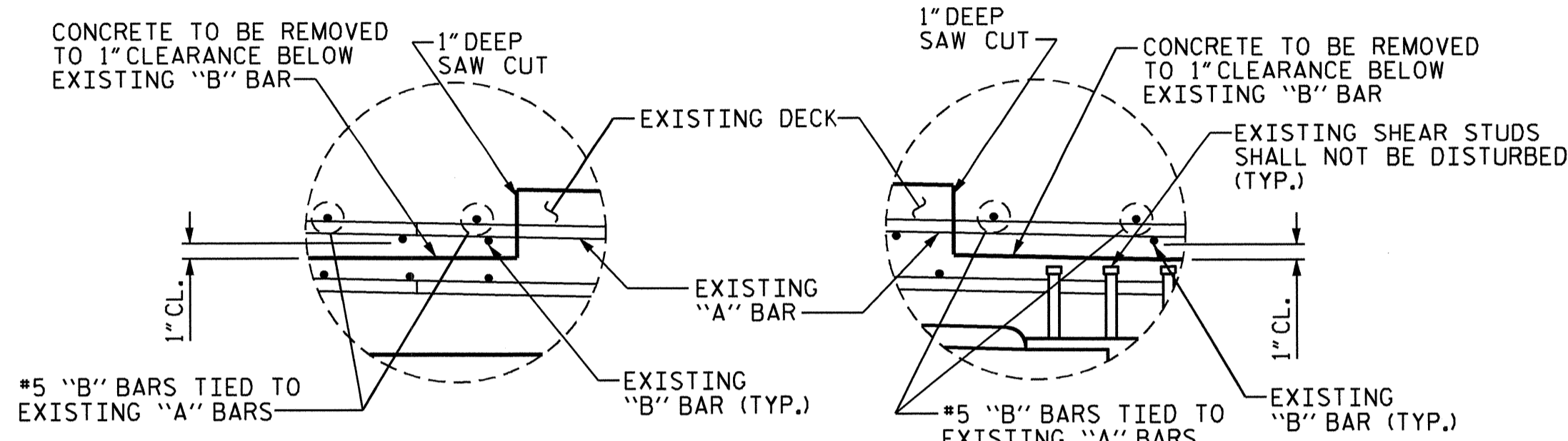

DETAIL A

DETAIL B

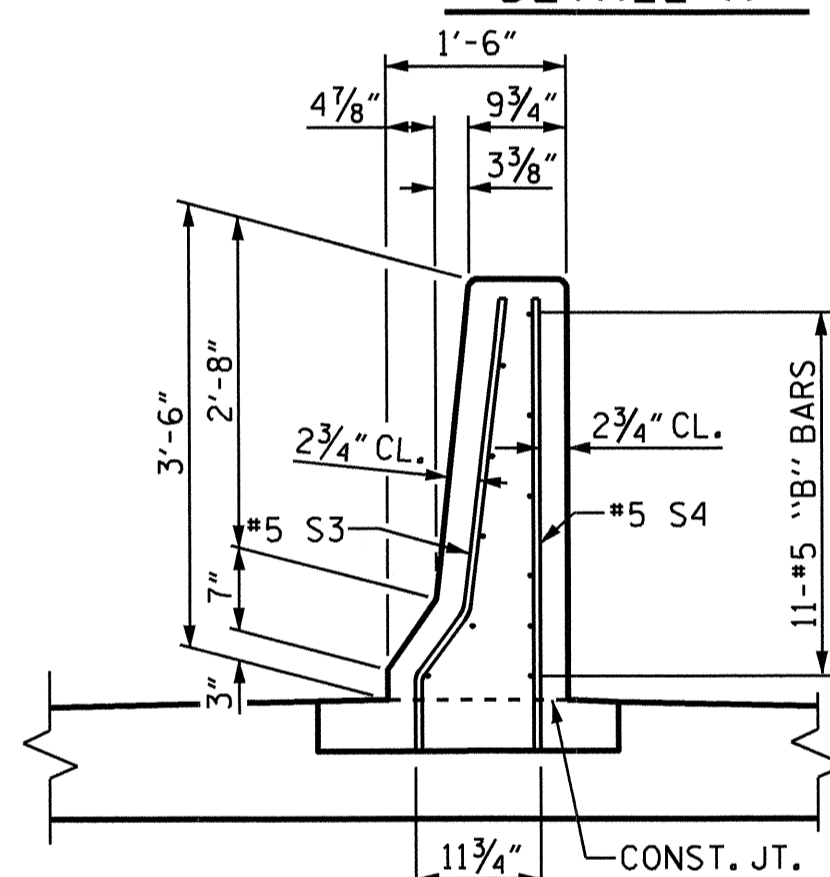

END VIEW

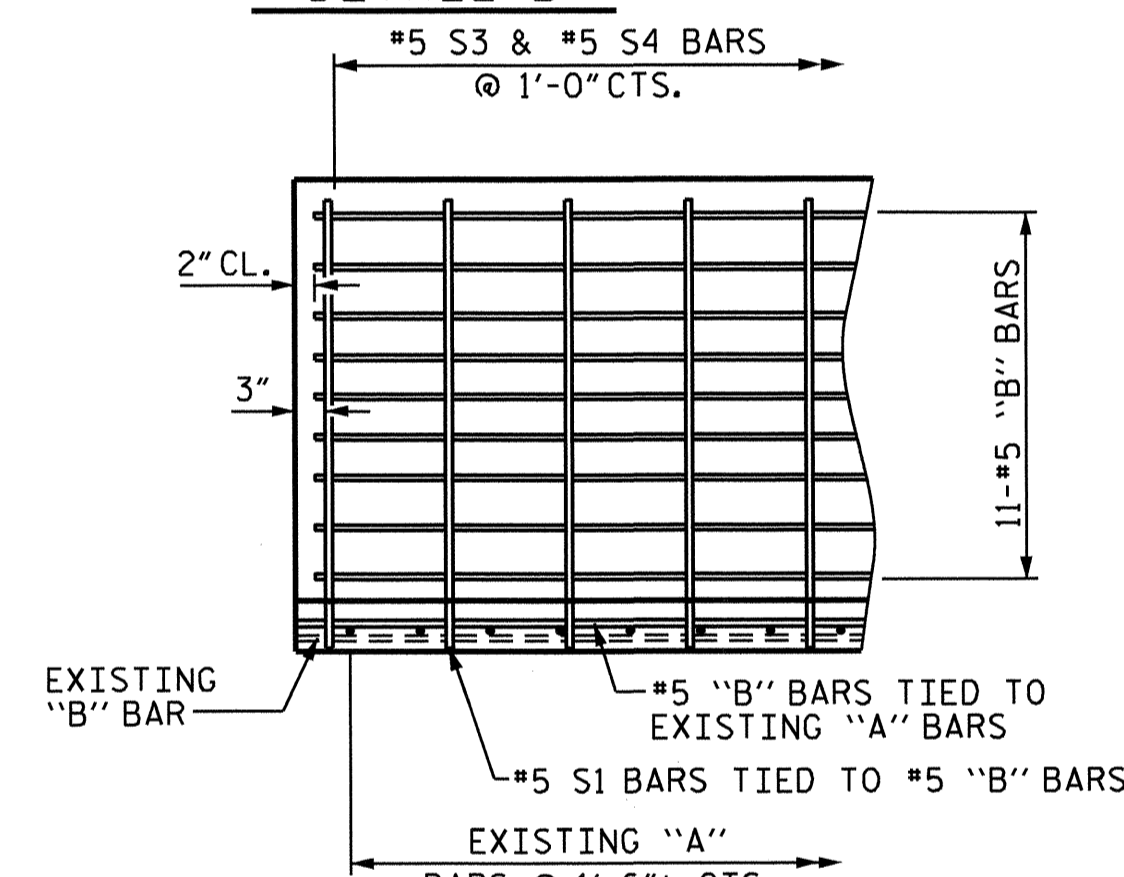

ELEVATION VIEW

END OF RAIL DETAIL @ APPROACH SLAB

FOR ADHESIVE ANCHORING AT SAWED JOINTS,
SEE 'END OF RAIL DETAIL AT APPROACH SLAB',
SHEET 4 OF 7.

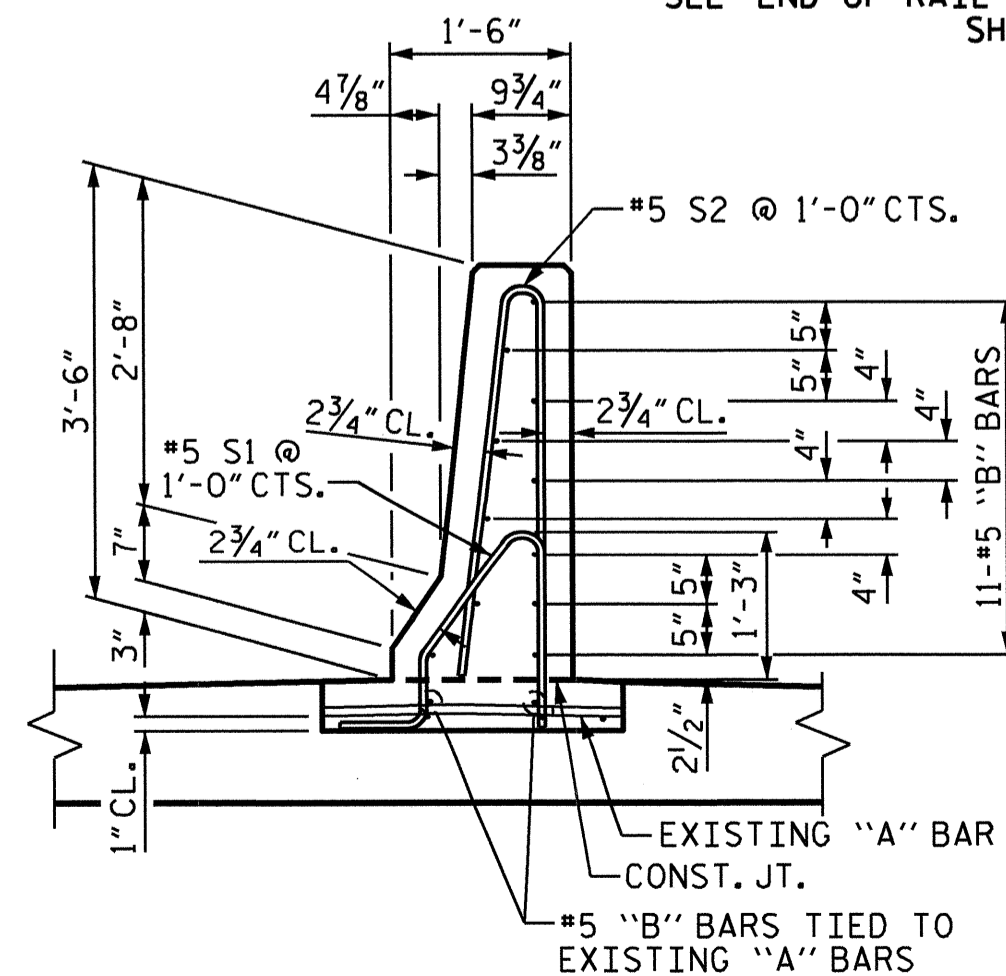

SECTION VIEW

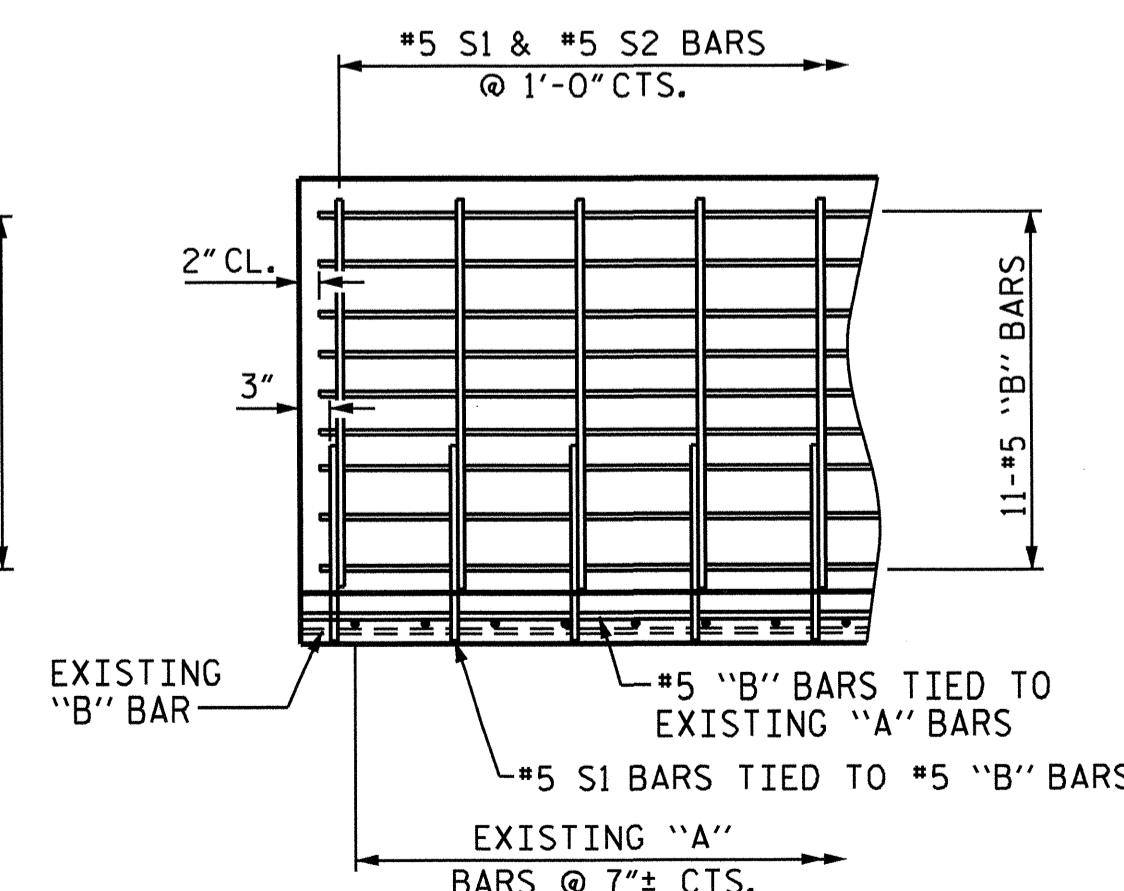

ELEVATION VIEW

BARRIER RAIL DETAIL

NOTES

THE BARRIER RAIL IN EACH SPAN SHALL NOT BE CAST UNTIL ALL PREVIOUSLY CONCRETE IN THAT SPAN HAS REACHED A MINIMUM COMPRESSIVE STRENGTH OF 3,000 PSI.

ALL REINFORCING STEEL IN DECK & BARRIER RAILS SHALL BE EPOXY COATED.

GROOVED CONTRACTION JOINTS, 1/2" IN DEPTH, SHALL BE TOOLED IN ALL EXPOSED FACES OF THE BARRIER RAIL AND IN ACCORDANCE WITH ARTICLE 825-10(B) OF THE STANDARD SPECIFICATIONS. THE CONTRACTION JOINT SHALL BE LOCATED AT EACH THIRD POINT BETWEEN BARRIER RAIL EXPANSION JOINTS. ONLY ONE CONTRACTION JOINT IS REQUIRED AT MIDPOINT OF BARRIER RAIL SEGMENTS LESS THAN 20 FEET IN LENGTH AND NO CONTRACTION JOINTS ARE REQUIRED FOR THOSE SEGMENTS LESS THAN 10 FEET IN LENGTH.

THE #5 S3 AND #5 S4 BARS SHALL BE INSTALLED, USING AN ADHESIVE ANCHORING SYSTEM, AFTER SAWING THE JOINT, THE YIELD LOAD FOR THE #5 S3 AND #5 S4 BARS IS 18.6 KIPS. FIELD TESTING FOR THE ADHESIVE BONDING SYSTEM IS NOT REQUIRED.

COST FOR ALL REINFORCING STEEL & CLASS AA CONCRETE IN DECK AND BARRIER RAIL SHALL BE PAID FOR UNDER THE PRICE BID FOR CONCRETE BARRIER RAIL.

THE BARRIER RAIL SHALL NOT BE CAST UNTIL THE FOAM JOINT SEAL SAWED OPENING HAS BEEN SAWED. SEE 'FOAM JOINT SEAL' SHEET.

BAR TYPES

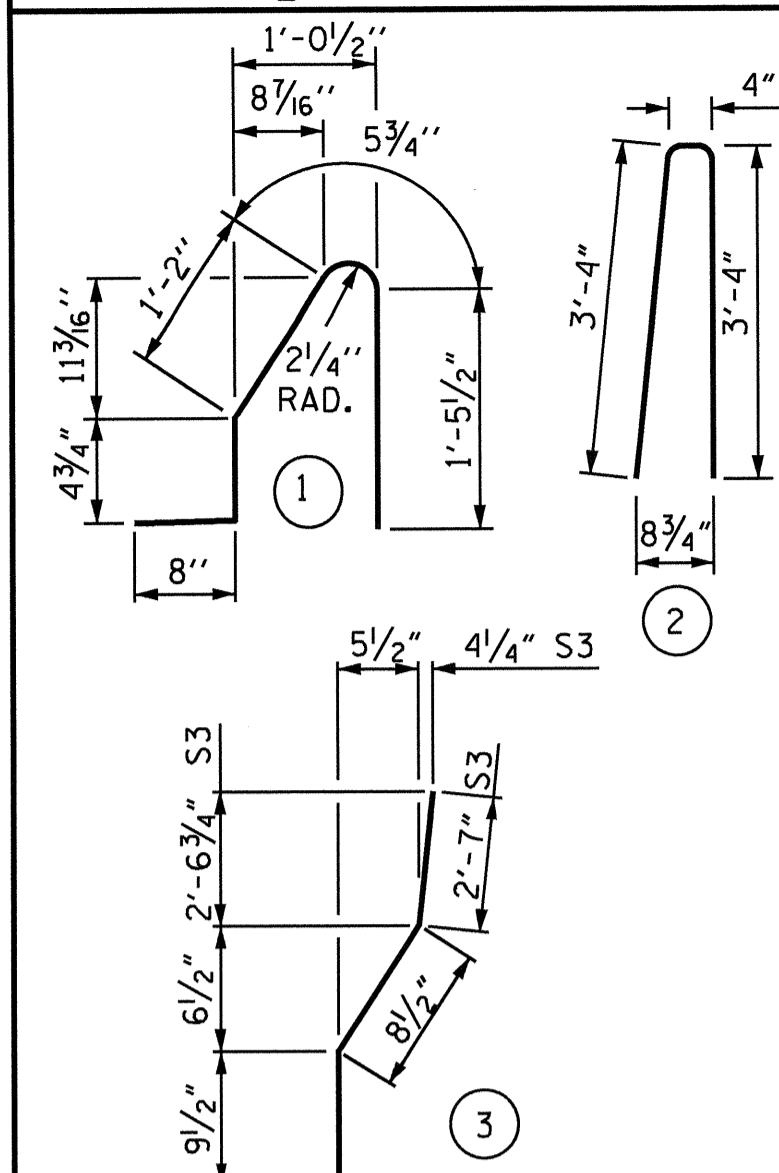

ALL BAR DIMENSIONS ARE OUT TO OUT

BILL OF MATERIAL

BAR	NO.	SIZE	TYPE	LENGTH	WEIGHT
* S1	632	#5	1	4'-2"	2747
* S2	632	#5	2	7'-0"	4614
* S3	24	#5	3	4'-1"	102
* S4	24	#5	STR	3'-9"	96
* B1	176	#5	STR	14'-2"	2601
* B2	110	#5	STR	22'-7"	2591
* B3	88	#5	STR	12'-2"	1117
* B4	88	#5	STR	13'-4"	1224
* B5	44	#5	STR	16'-7"	761
* B6	8	#5	STR	16'-1"	134
* B7	4	#5	STR	40'-8"	170
* B8	16	#5	STR	48'-8"	812
* B9	8	#5	STR	35'-5"	296

* EPOXY COATED REINFORCING STEEL	17,265 LBS.
CLASS AA CONCRETE DECK	26 CU. YDS.
BARRIER RAIL	91 CU. YDS.
TOTAL	117 CU. YDS.
CONCRETE BARRIER RAIL	668.63 LIN. FT.

* THESE BARS ARE EPOXY COATED.

PROJECT NO. I-5501
HENDERSON COUNTY
 STATION: 25+83.78 -L-

SHEET 3 OF 7

STATE OF NORTH CAROLINA
 DEPARTMENT OF TRANSPORTATION
 RALEIGH

TYPICAL SECTION
 BRIDGE No.240 ON
 NC 280 OVER I-26

REVISIONS

NO.	BY:	DATE:	NO.	BY:	DATE:
1			3		
2			4		

SHEET NO.
S-3

TOTAL SHEETS
7

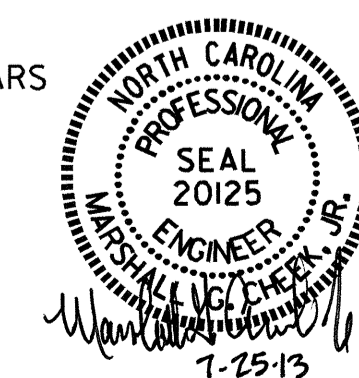

DRAWN BY: W.J. HARRIS DATE: 3/20/13
 CHECKED BY: M.G. CHEEK DATE: 5/13

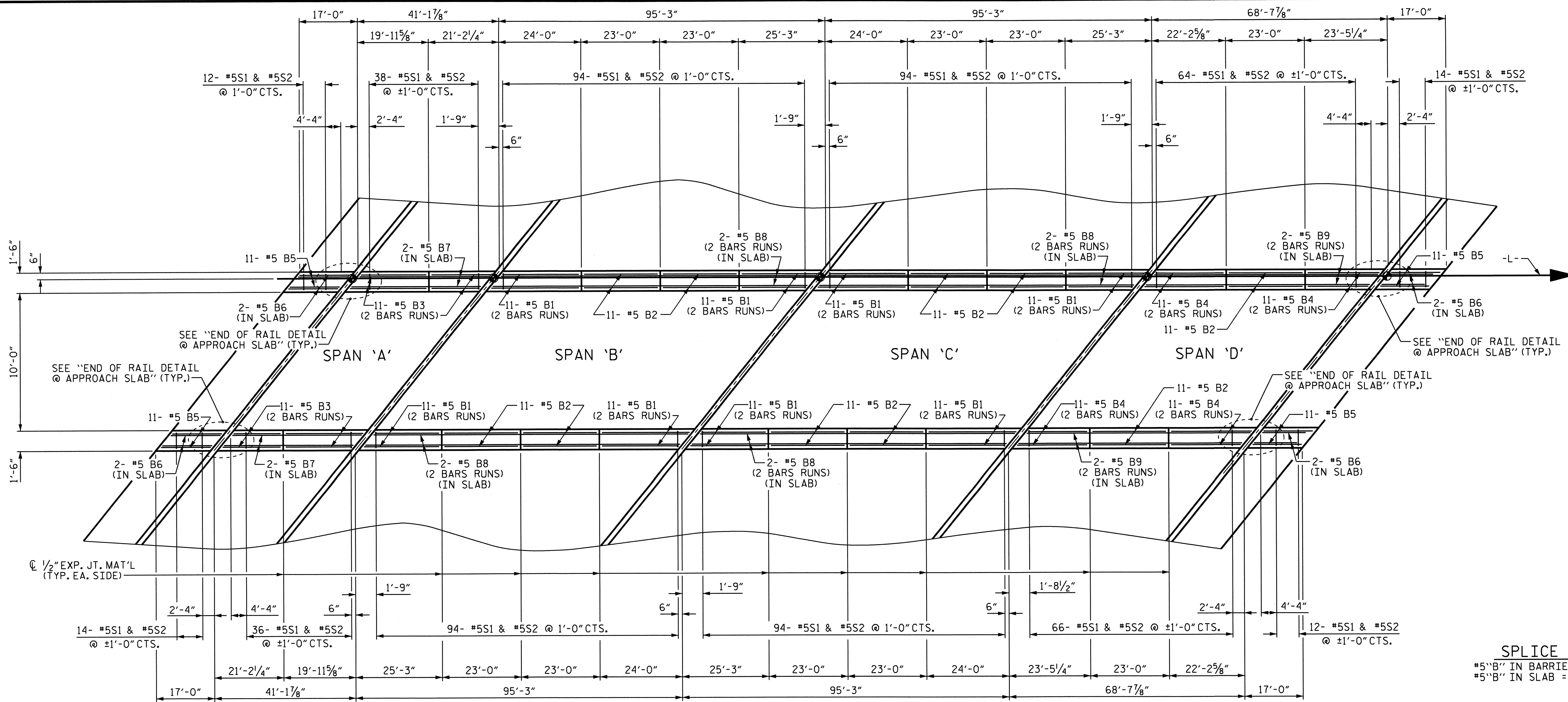

SPLICE CHART
 #5" B" IN BARRIER RAIL = 3'-5"
 #5" B" IN SLAB = 2'-6"

PLAN

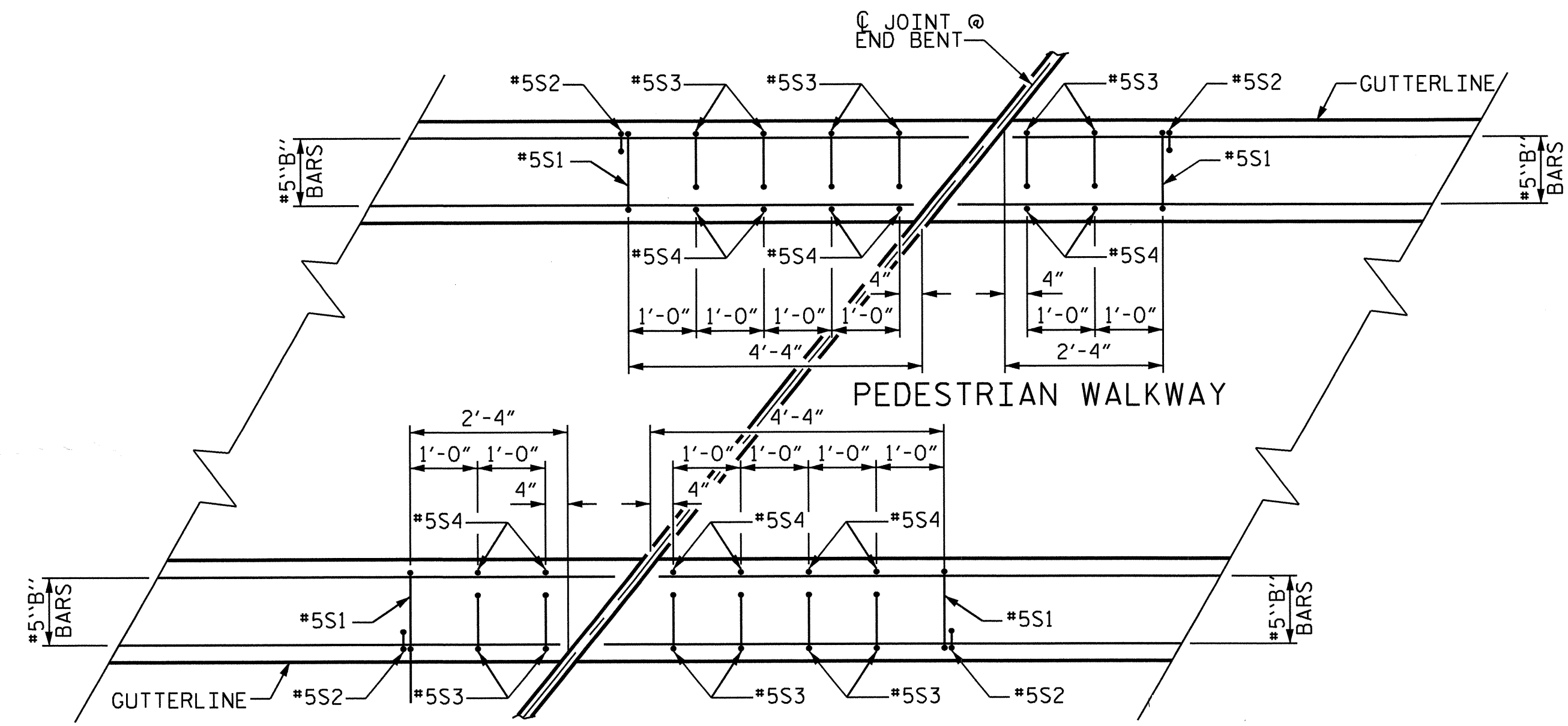

END OF RAIL DETAIL @ APPROACH SLAB

DRAWN BY : W.J. HARRIS DATE : 3/20/13
 CHECKED BY : M.G. CHEEK DATE : 5/13

23-JUL-2013 09:26
 R:\Structures\Final Plans\I-5501.SD.TS.dgn
 wjharris

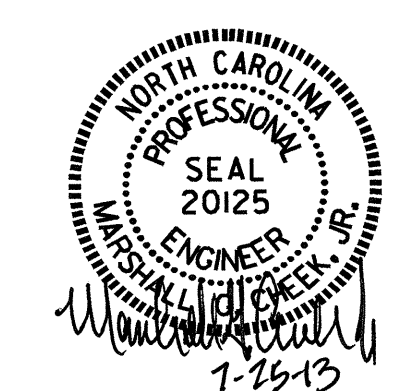

PROJECT NO. I-5501
HENDERSON COUNTY
 STATION: 25+83.78 -L-

SHEET 4 OF 7

STATE OF NORTH CAROLINA DEPARTMENT OF TRANSPORTATION RALEIGH					
CONCRETE BARRIER RAIL					
REVISIONS					
NO.	BY:	DATE:	NO.	BY:	DATE:
1			3		
2			4		
					SHEET NO. S-4
					TOTAL SHEETS 7

NC006

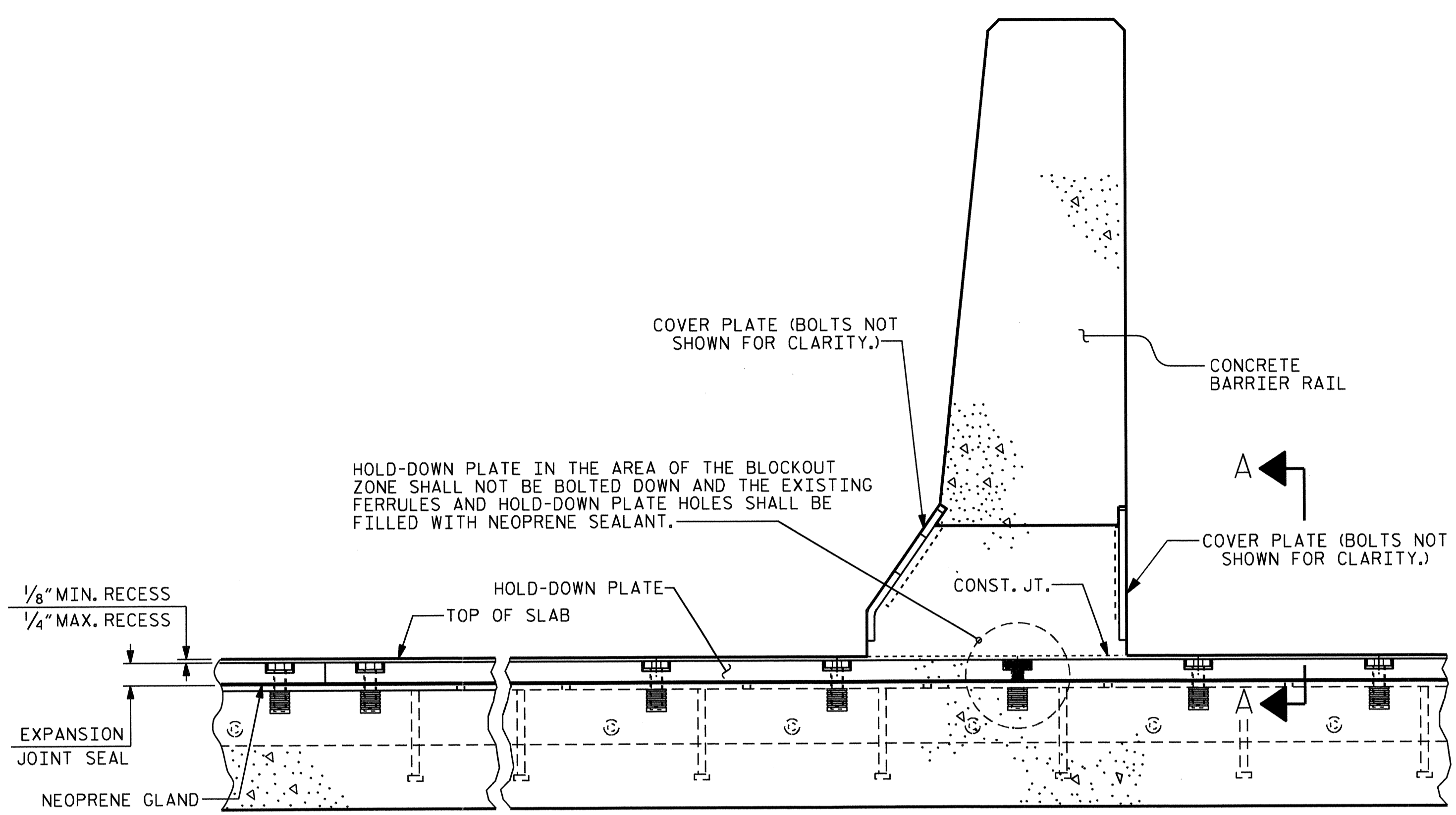

SECTION THRU PEDESTRIAN RAIL NORMAL TO JOINT

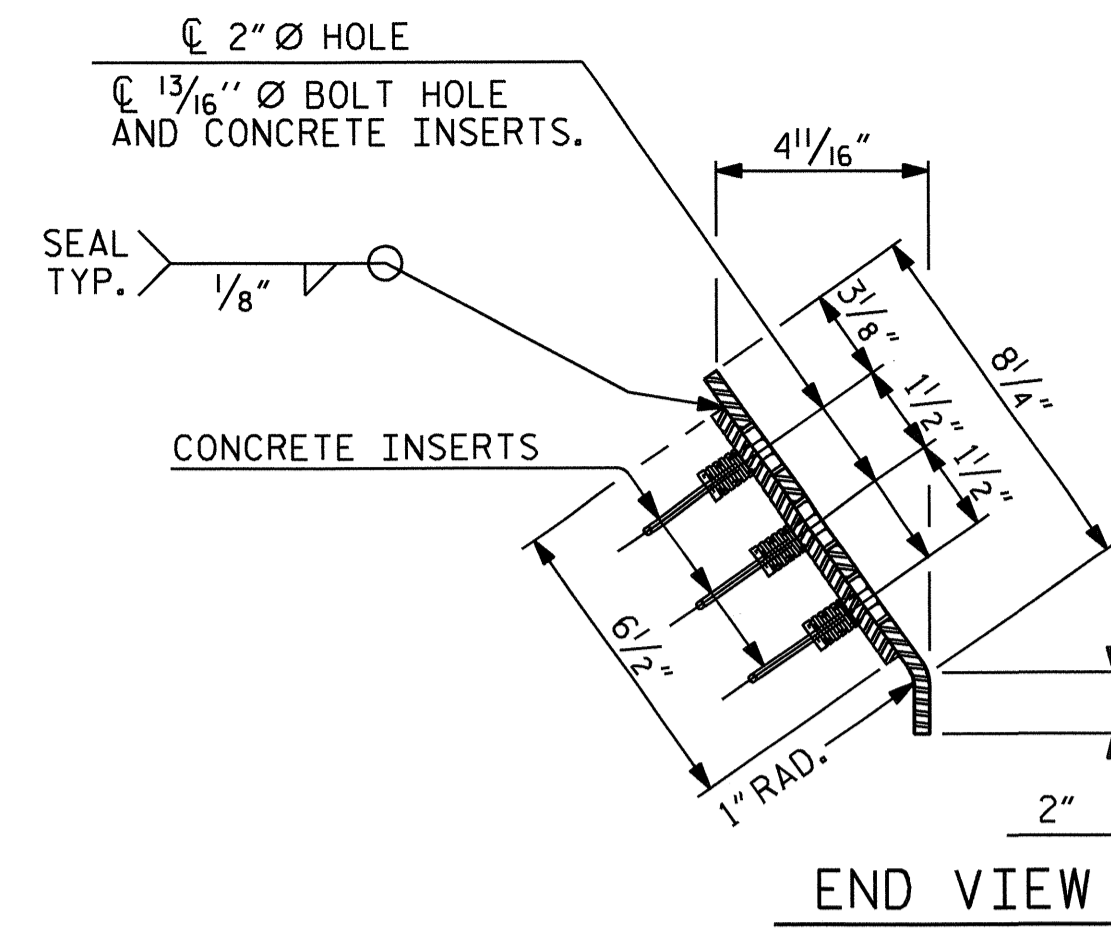

END VIEW

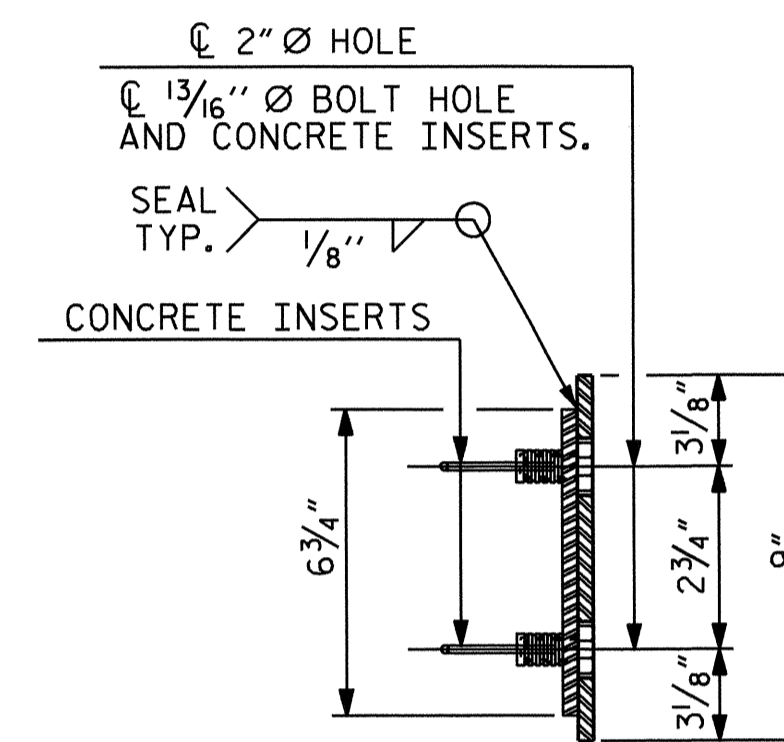

END VIEW

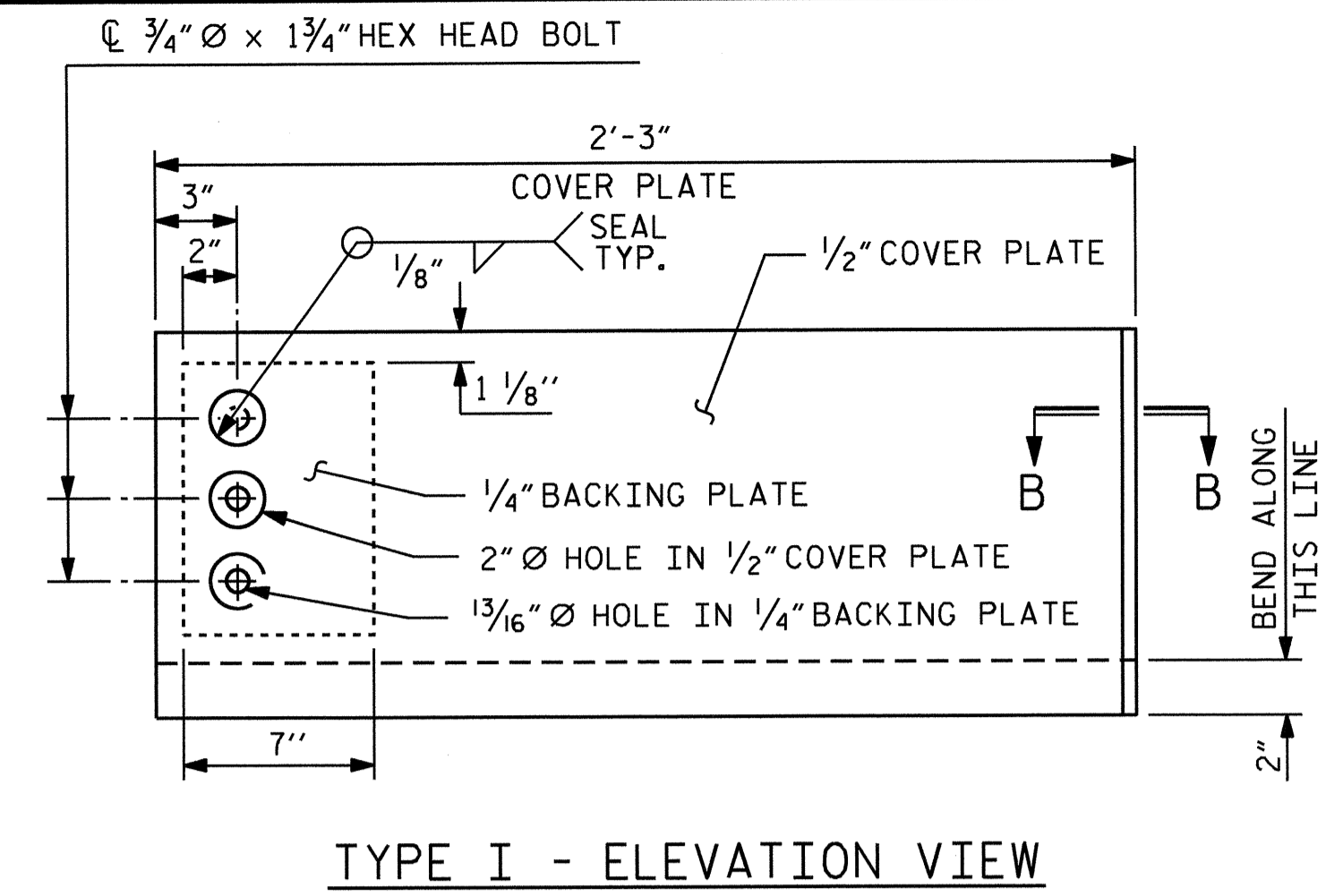

TYPE I - ELEVATION VIEW

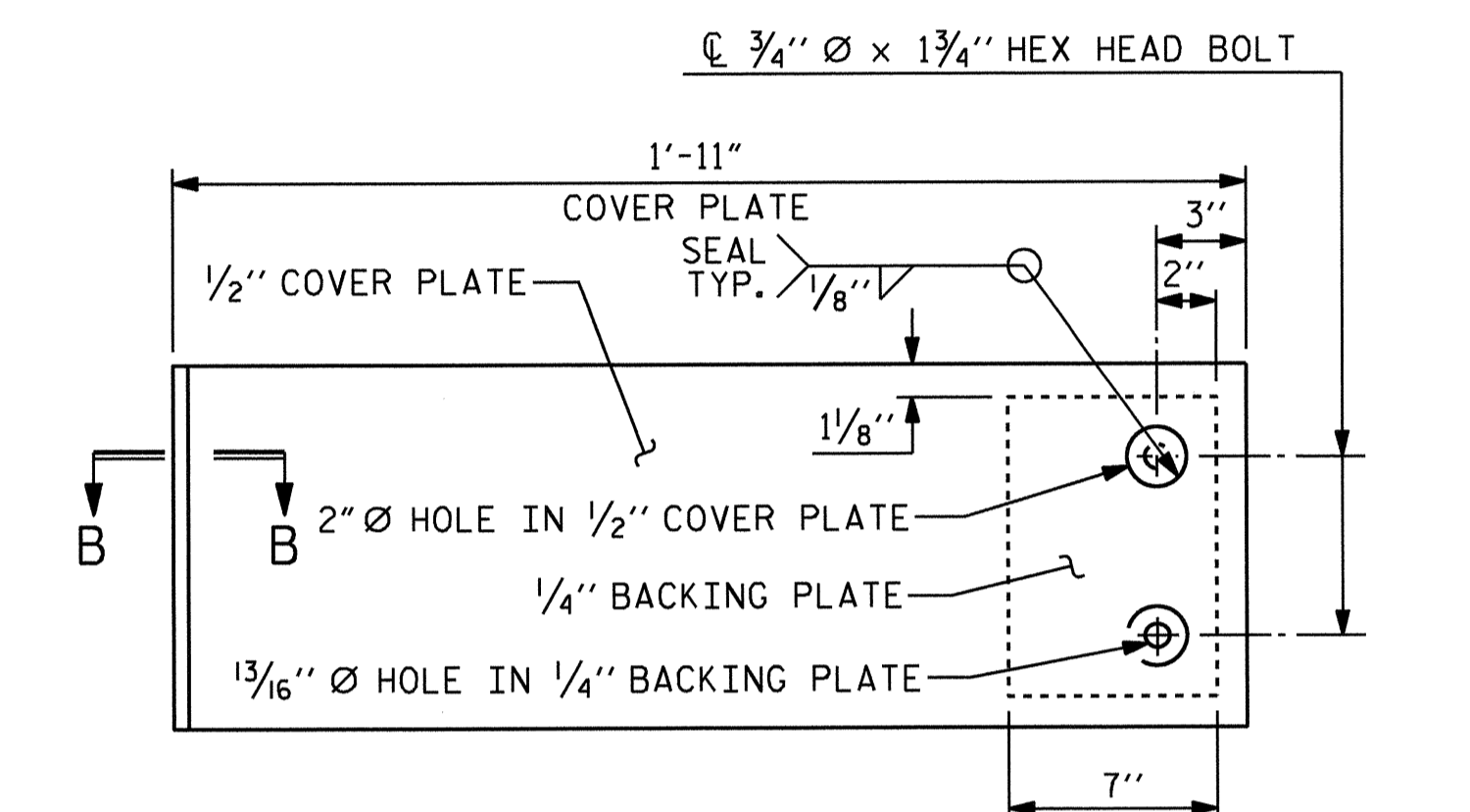

TYPE II - ELEVATION VIEW

COVER PLATE DETAILS

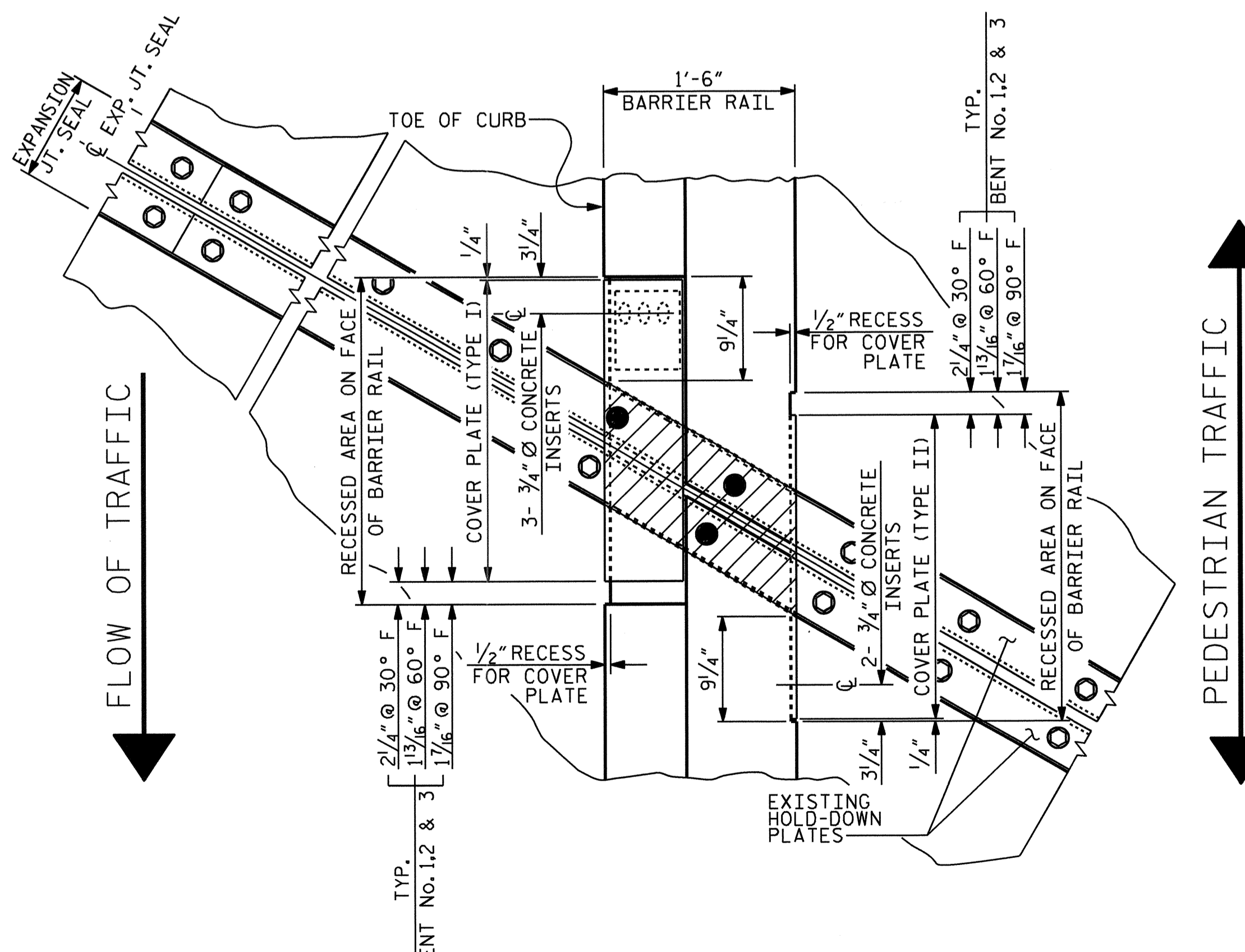

PLAN OF EXPANSION JOINT SEAL

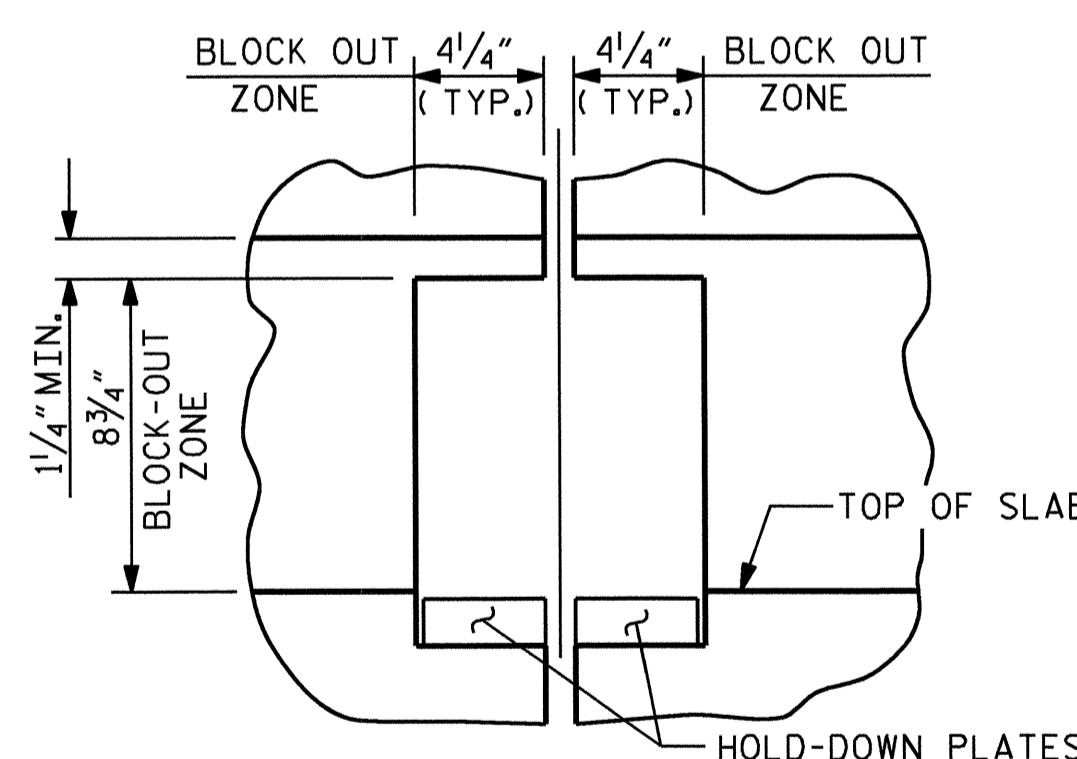

SECTION A - A

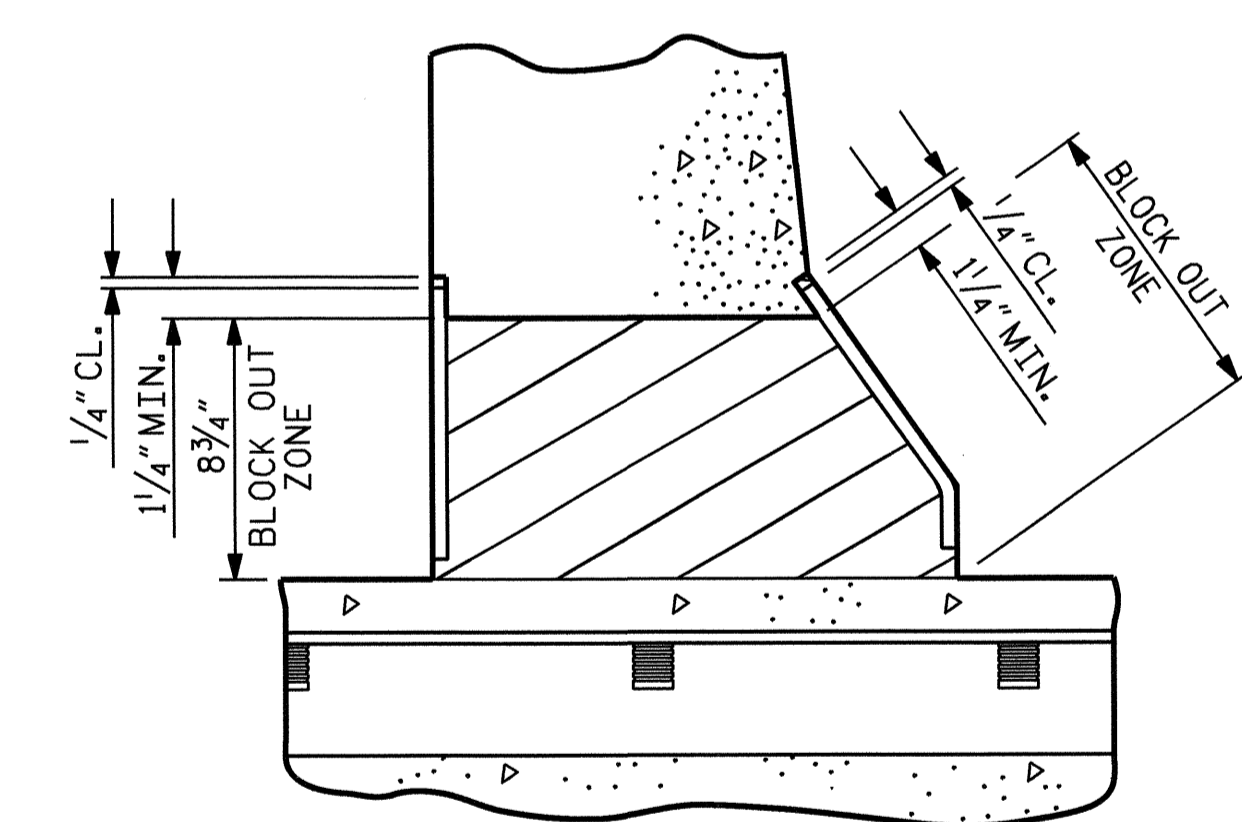

BLOCK OUT DETAIL

SEE "SECTION A - A" FOR OTHER DETAILS.

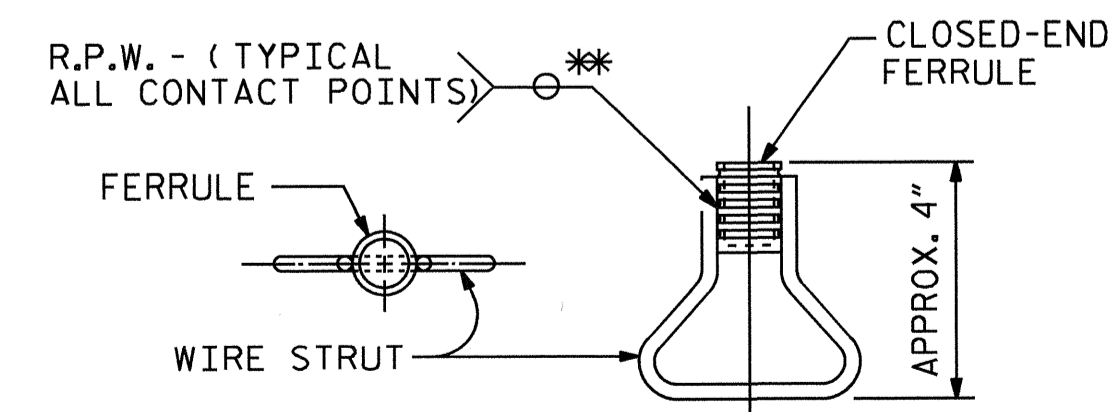

PLAN ELEVATION

CONCRETE INSERT

* EACH WELDED ATTACHMENT OF WIRE TO FERRULE SHALL DEVELOP THE TENSILE STRENGTH OF THE WIRE.

PROJECT NO. I-5501
 HENDERSON COUNTY
 STATION: 25+83.78 -L-

SHEET 5 OF 7

STATE OF NORTH CAROLINA
 DEPARTMENT OF TRANSPORTATION
 RALEIGH

EXPANSION JOINT SEAL DETAILS FOR BARRIER RAIL

REVISIONS						SHEET NO.	
NO.	BY:	DATE:	NO.	BY:	DATE:	S-5	
1			3			TOTAL SHEETS	
2			4			7	



NCBDS

DRAWN BY: W.J. HARRIS DATE: 3/20/13
 CHECKED BY: M.G. CHEEK DATE: 5/13

INSTALLATION PROCEDURE

1. THE EXISTING HOLD-DOWN PLATES SHALL BE REMOVED AND CLEANED AND THE BASE ANGLES SHALL BE CLEANED TO THE EXTENT PRACTICAL. THE HOLD-DOWN PLATES AND BASE ANGLES SHALL BE PAINTED WITH TWO (2) COATS OF ZINC-RICH PAINT IN ACCORDANCE WITH THE SPECIFICATIONS. EACH COAT SHALL HAVE A MINIMUM THICKNESS OF 3 MILS. PAINTED SURFACES THAT ARE ABRADED OR DAMAGED AT ANY TIME AFTER THE APPLICATION OF THE ZINC COATING SHALL BE REPAIRED AS SPECIFIED FOR DAMAGED GALVANIZING.
2. THE EXISTING GLAND SHALL BE REPLACED WITH A NEW NEOPRENE OR EPDM GLAND WHICH SHALL BE CONTINUOUS ACROSS THE LENGTH OF THE JOINT.
3. LAY THE GLAND ON THE BASE ANGLE AND FIELD MARK THE GLAND FOR THE BOLT HOLES. HOLES IN THE GLAND SHALL BE PUNCHED $\frac{1}{8}$ " IN DIAMETER WITH A HAND PUNCH.
4. IN ORDER TO CHECK FOR PROPER ALIGNMENT, PLACE THE GLAND AND HOLD-DOWN PLATES ON THE BASE ANGLE. DO NOT APPLY NEOPRENE SEALANT. BOLT THE HOLD-DOWN PLATES TO THE BASE ANGLE BUT DO NOT TIGHTEN. THE ENGINEER SHALL INSPECT THE JOINT SEAL DEVICE FOR PROPER ALIGNMENT.
5. AFTER INSPECTION, REMOVE THE HOLD-DOWN PLATES AND GLAND. APPLY NEOPRENE SEALANT TO THE BASE ANGLE IN ACCORDANCE WITH THE "INSTALLATION SKETCH". PLACE GLAND AND HOLD-DOWN PLATES ON THE BASE ANGLE. BOLT THE HOLD-DOWN PLATES TO THE BASE ANGLE ASSEMBLY AND TORQUE THE BOLTS TO 88 FT-LBS WITH A TORQUE WRENCH. THE TORQUE WRENCH SHALL BE CALIBRATED IN ACCORDANCE WITH SECTION 440-10 (D) OF THE STANDARD SPECIFICATIONS. CHECK THE TORQUE AFTER THREE (3) HOURS AND, IF NECESSARY, RETIGHTEN TO 88 FT-LBS. A FINAL CHECK SHALL BE MADE AT SEVEN (7) DAYS. TORQUE SHALL NOT BE LESS THAN 80 FT-LBS AFTER SEVEN (7) DAYS.
6. AFTER PROPER TORQUING, CLEAN THE BOLT HOLE RECESSES AND THE RECESS BETWEEN THE JOINT SEAL DEVICE AND CONCRETE, AND COMPLETELY FILL THESE RECESSES WITH NEOPRENE SEALANT.
7. HOLD-DOWN PLATE IN THE AREA OF THE BLOCKOUT ZONE SHALL NOT BE BOLTED DOWN AND THE EXISTING FERRULES AND HOLD-DOWN PLATE HOLES SHALL BE FILLED WITH NEOPRENE SEALANT.

GENERAL NOTES

1. FOR EXPANSION JOINT SEALS, SEE EXPANSION JOINT ELASTOMERIC SEAL REPLACEMENT SPECIAL PROVISION.
2. A PREMOLDED CORRUGATED OR NON-CORRUGATED GLAND SHALL BE USED FOR JOINTS SKEWED BETWEEN 50° THRU 130°.
3. ALL COVER PLATES SHALL CONFORM TO ASSHTO M270 GRADE 36 STEEL OR APPROVED EQUAL AND SHALL BE GALVANIZED IN ACCORDANCE WITH AASHTO M111. ALL HOLD-DOWN BOLTS SHALL CONFORM TO ASTM F593 ALLOY 304 STAINLESS STEEL AND WASHERS SHALL CONFORM TO ASTM F844 EXCEPT THEY SHALL BE MADE FROM ALLOY 304 STAINLESS STEEL. ALL CONCRETE INSERTS SHALL BE CLOSED END AND SHALL CONFORM TO ASSHTO M169, GRADE 12L14, TENSILE CAPACITY SHALL BE 3000 LBS. MIN.
4. CLOSED END FERRULES SHALL BE SHOP WELDED AND ALL HOLES SHALL BE SHOP DRILLED AS SHOWN ON PLANS.
5. THE CONTRACTOR MAY, AT HIS OPTION, USE ADHESIVELY ANCHORED ANCHOR BOLTS IN PLACE OF CONCRETE INSERTS FOR COVER PLATES. THE YIELD LOAD OF THE $\frac{3}{4}$ " Ø BOLT IS 10 KIPS. FIELD TESTING OF THE ADHESIVE BONDING SYSTEM IS NOT REQUIRED.
6. THE COST OF THE COVER PLATES SHALL BE PAID FOR UNDER THE LUMP SUM PRICE BID FOR EXPANSION JOINT SEALS.
7. SHOULD ANY EXISTING BASE ANGLE FERRULES BE UNABLE TO BE REUSED, THE CONTRACTOR SHALL USE ADHESIVELY ANCHORED BOLTS AT THOSE LOCATIONS. THE YIELD LOAD OF THE $\frac{3}{4}$ " Ø BOLT IS 10 KIPS. FIELD TESTING OF THE ADHESIVE BONDING SYSTEM IS NOT REQUIRED.

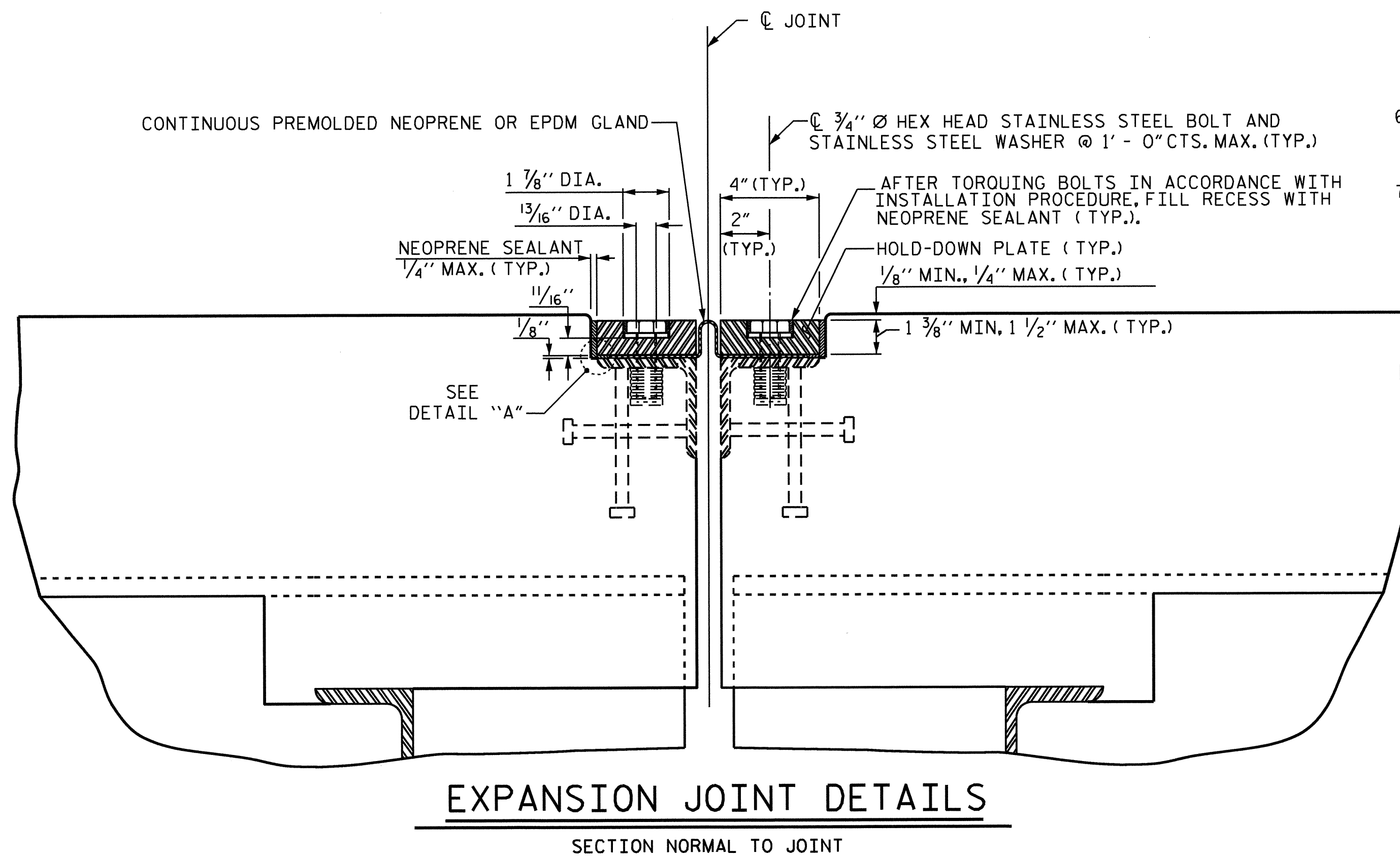

EXPANSION JOINT DETAILS

SECTION NORMAL TO JOINT

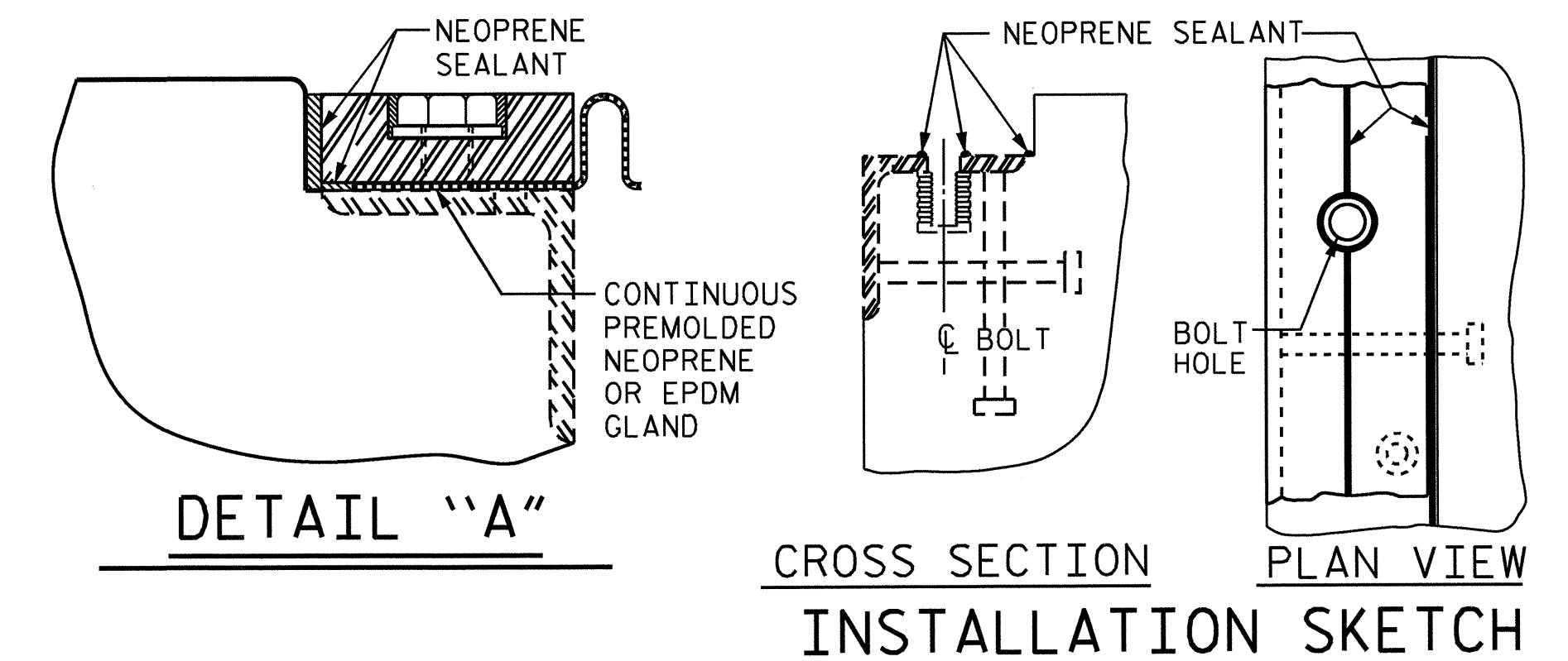

DETAIL "A"

**CROSS SECTION
PLAN VIEW
INSTALLATION SKETCH**

MOVEMENT AND SETTING AT JOINT					
BENT NO.	SKEW ANGLE	TOTAL MOVEMENT (ALONG \bar{C} RDWY)	PERPENDICULAR JOINT OPENING AT 30° F	PERPENDICULAR JOINT OPENING AT 60° F	PERPENDICULAR JOINT OPENING AT 90° F
1	129°-03'-27"	1 5/8"	1 5/16"	1 5/8"	1 5/16"
2	129°-03'-27"	1 5/8"	1 5/16"	1 5/8"	1 5/16"
3	129°-03'-27"	1 5/8"	1 5/16"	1 5/8"	1 5/16"

PROJECT NO. I-5501
HENDERSON COUNTY
 STATION: 25+83.78 -L-

SHEET 6 OF 7

STATE OF NORTH CAROLINA
 DEPARTMENT OF TRANSPORTATION
 RALEIGH

EXPANSION JOINT SEAL DETAILS



DRAWN BY: W.J. HARRIS DATE: 3/20/13
 CHECKED BY: M.G. CHEEK DATE: 5/13

REVISIONS						SHEET NO.
NO.	BY:	DATE:	NO.	BY:	DATE:	S-6
1			3			TOTAL SHEETS
2			4			7

NOTES

FOR FOAM JOINT SEAL REPLACEMENT, SEE SPECIAL PROVISIONS.

SEE SPECIAL PROVISIONS FOR ELASTOMERIC CONCRETE.

THE REMOVAL AND REPLACEMENT OF THE EXISTING COMPRESSION JOINT SEALS, REMOVAL OF THE EXISTING CONCRETE IN THE BRIDGE DECK AND APPROACH SLABS, PLACEMENT OF THE ELASTOMERIC CONCRETE HEADERS AND INSTALLATION OF THE FOAM JOINT SEALS SHALL BE INCLUDED IN THE LUMP SUM PRICE BID FOR FOAM JOINT SEALS. FOR SAWING THE ELASTOMERIC CONCRETE BLOCKOUT IN THE EXISTING DECK, SEE FOAM JOINT SEAL REPLACEMENT SPECIAL PROVISION.

THE NOMINAL UNCOMPRESSED SEAL WIDTH OF THE EVAZOTE JOINT SEAL SHALL BE 2".

FOR REMOVAL OF CONCRETE IN DECK AND APPROACH SLABS, FOR THE ELASTOMERIC CONCRETE PLACEMENT, SEE BRIDGE JOINT DEMOLITION SPECIAL PROVISION.

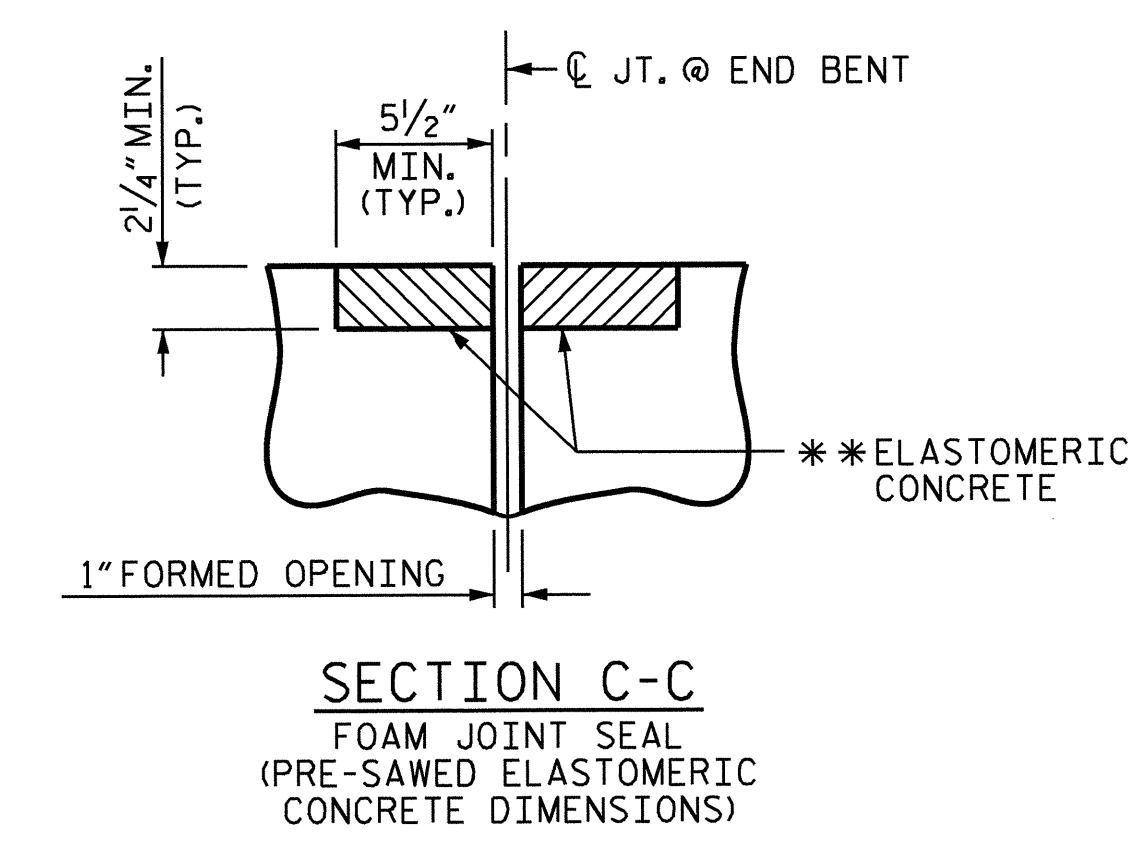
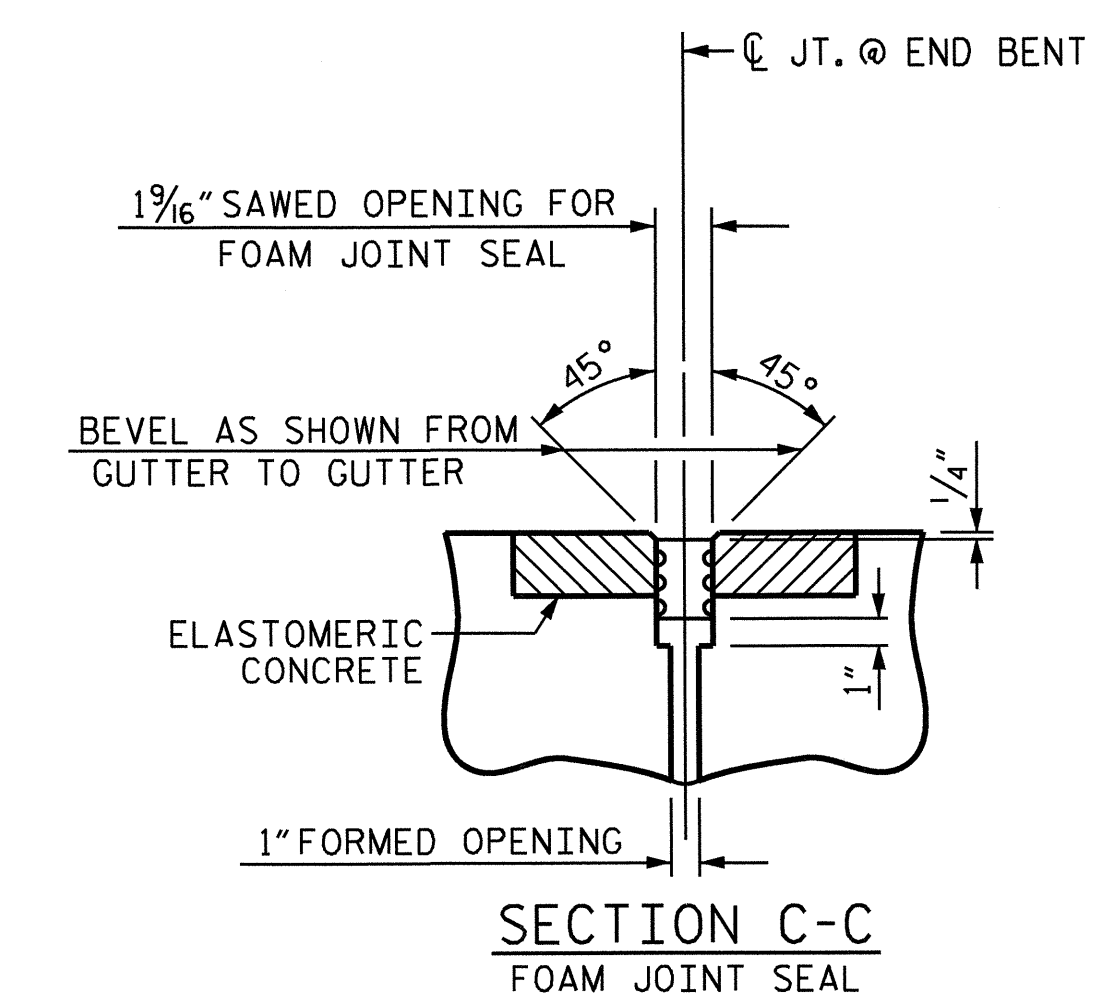
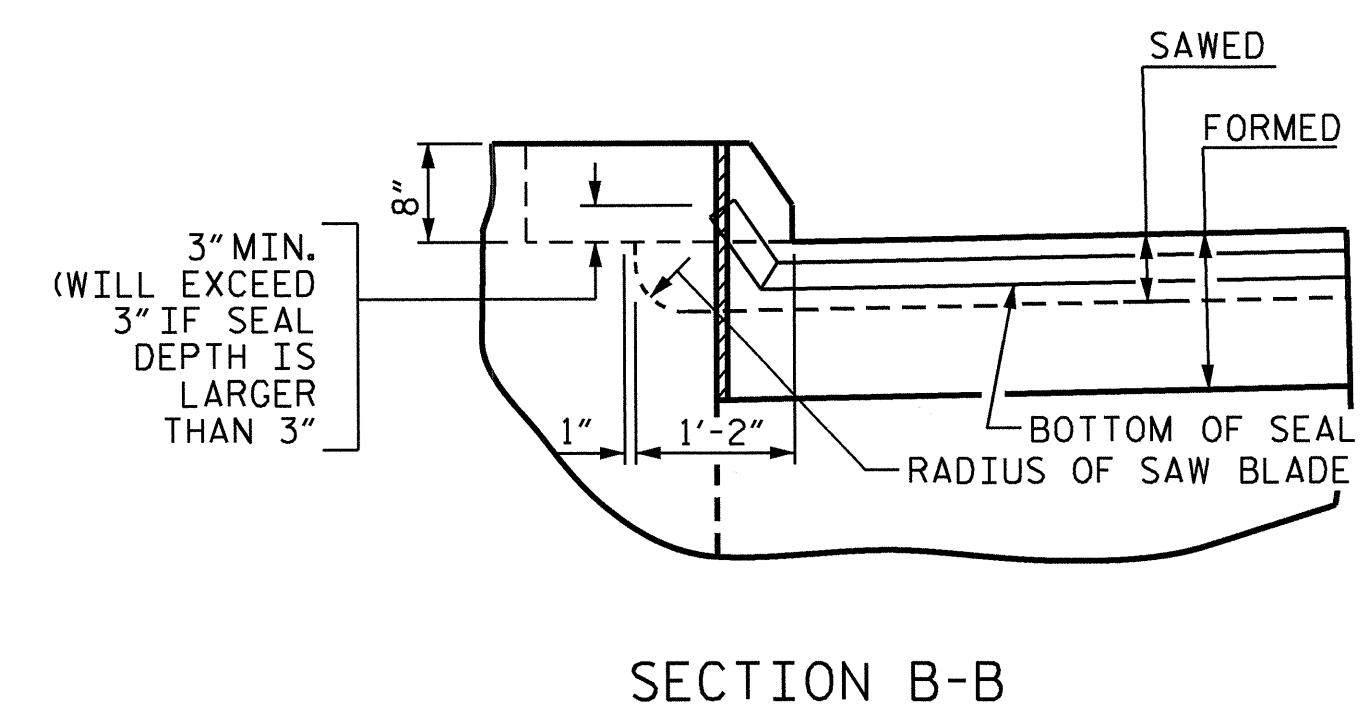
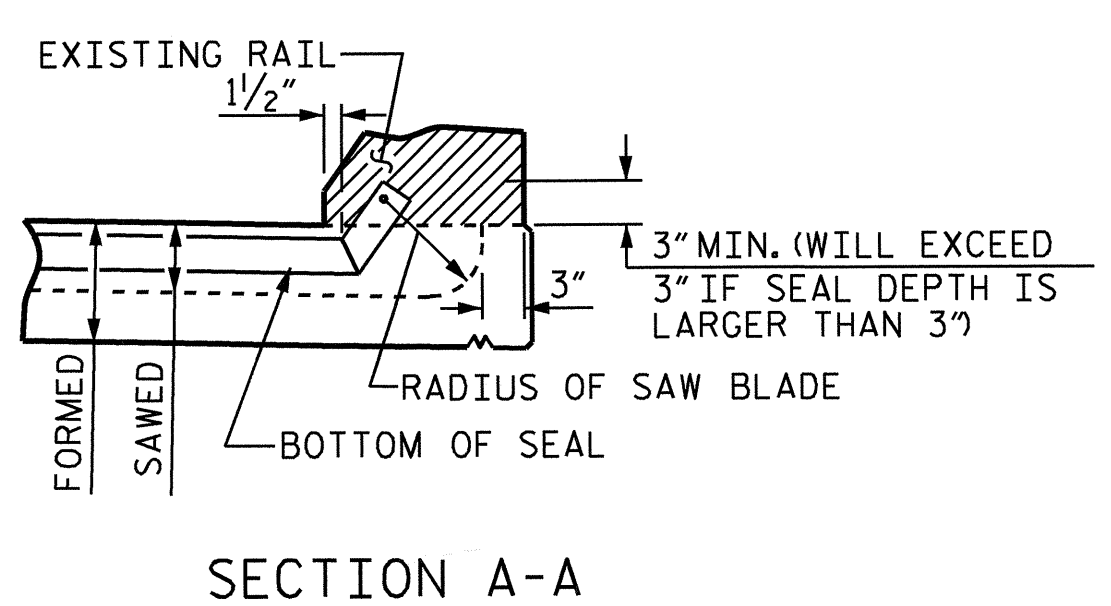
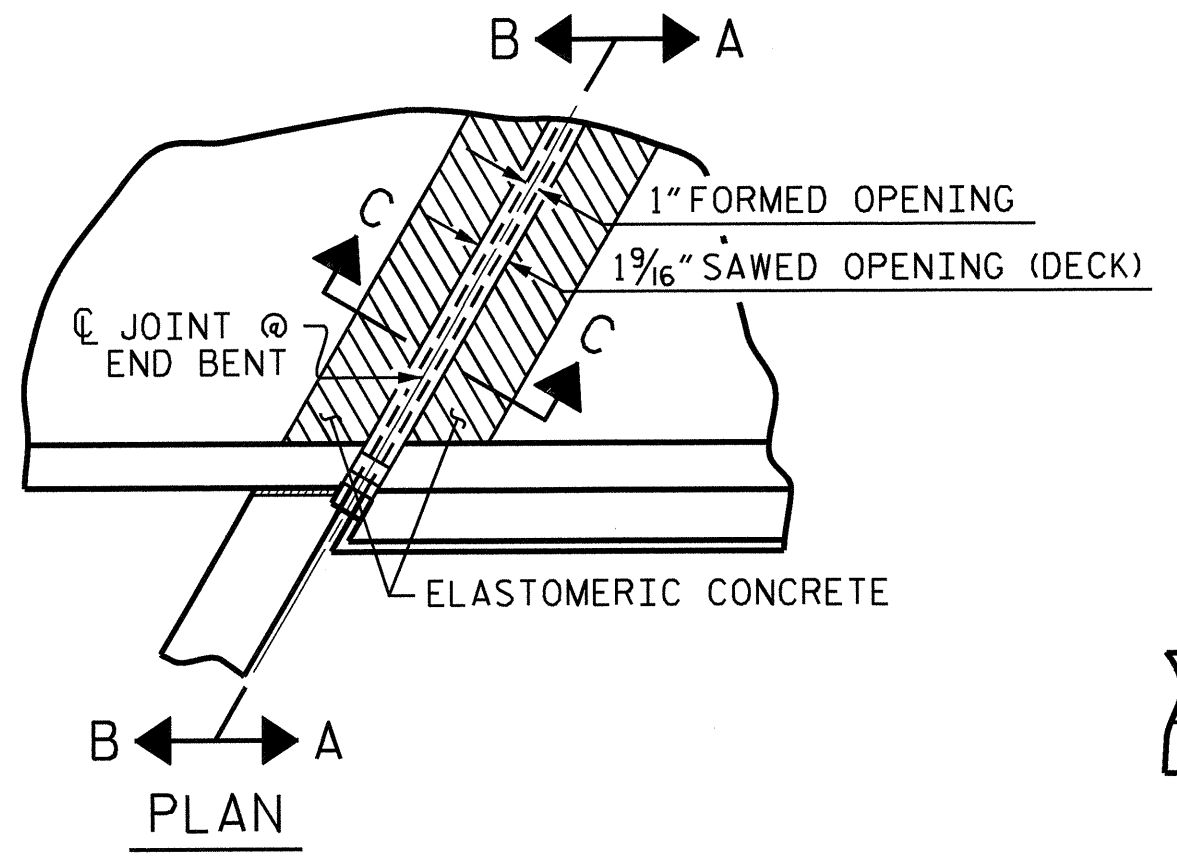
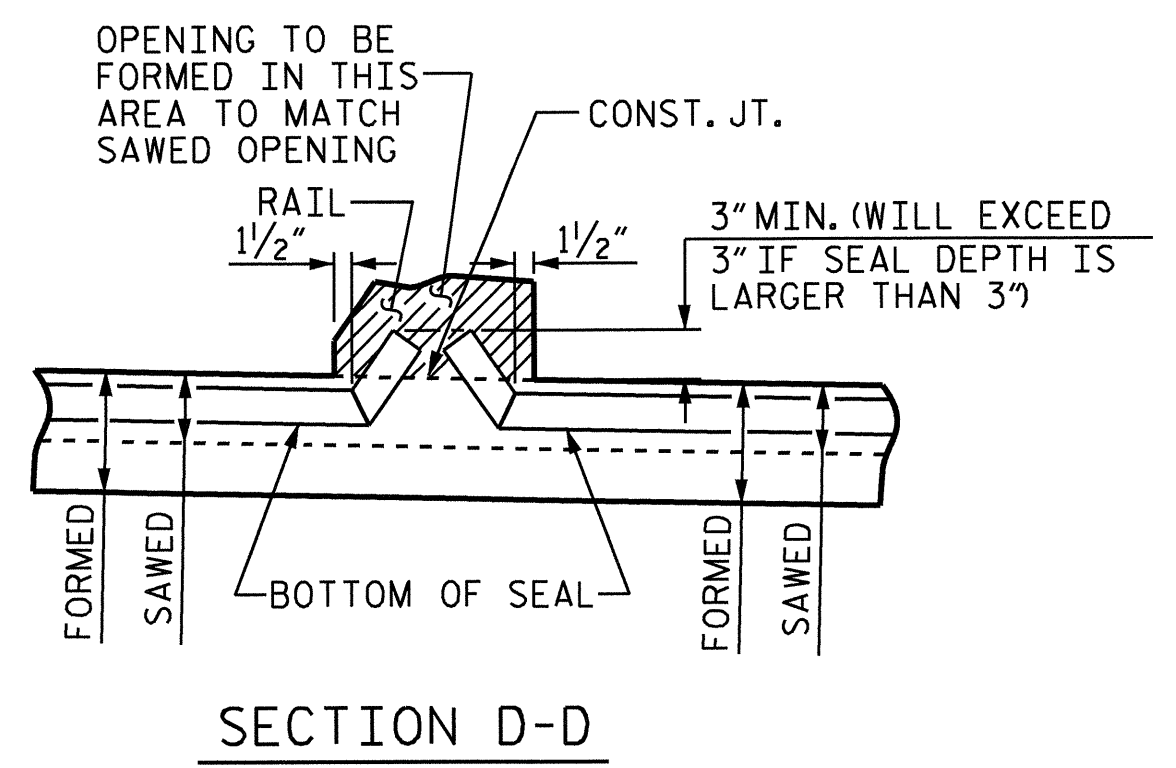
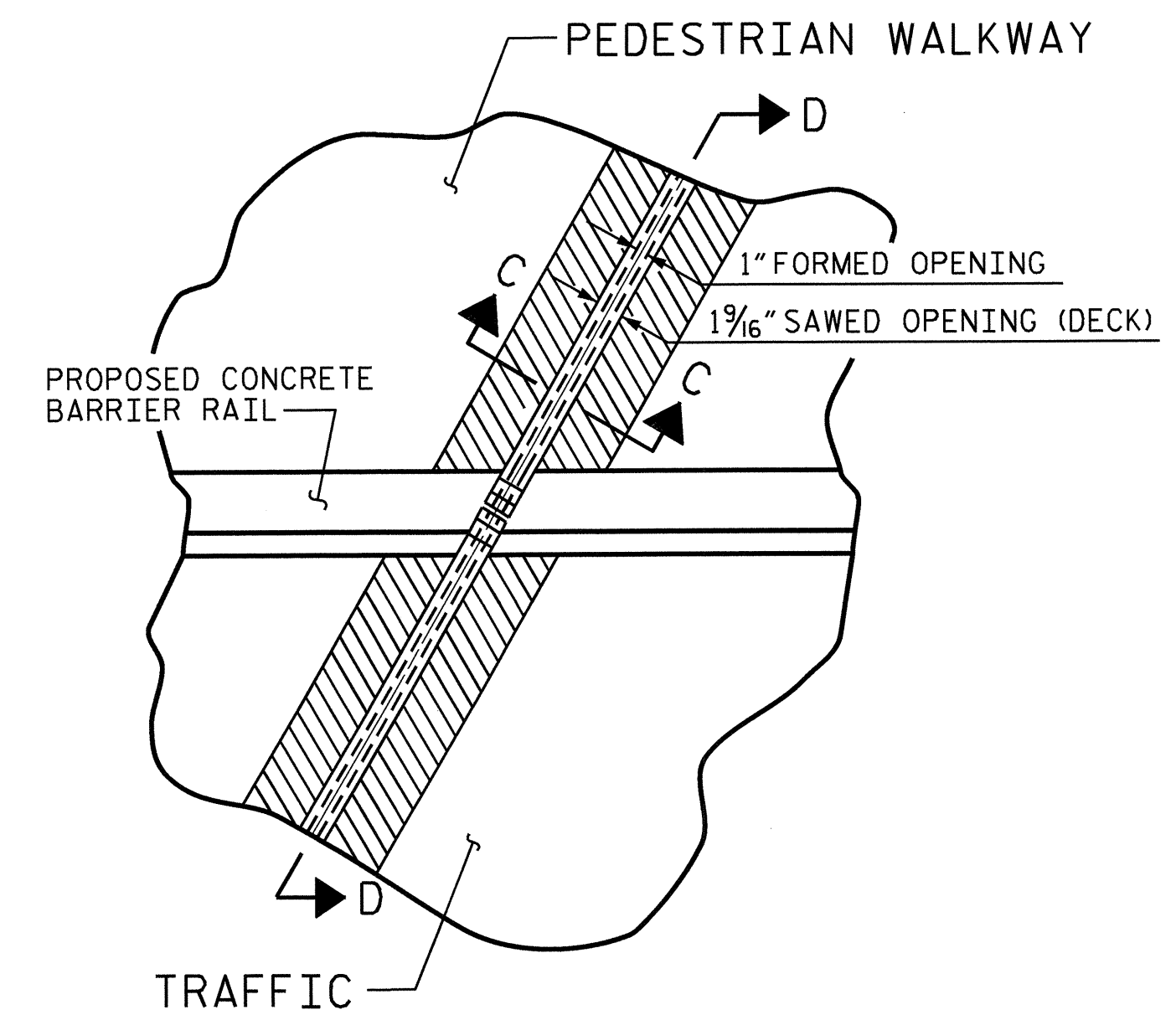

BILL OF MATERIAL	
END BENT NO.	ELASTOMERIC CONCRETE * (CU. FT.)
1	17.2
2	17.2
TOTAL	34.4

* BASED ON THE MINIMUM DIMENSIONS SHOWN.

PROPOSED FOAM JOINT SEAL DETAILS @ END BENT

FOAM JOINT SEAL TO BE CUT, HEAT WELDED AND TURNED UP PARALLEL TO SLOPED FACE OF THE BARRIER RAIL.

THE JOINT SHALL BE SAWS PRIOR TO THE CASTING OF THE CONCRETE BARRIER RAIL.

** EXISTING CONCRETE IN DECK AND APPROACH SLABS TO BE REMOVED TO THE MINIMUM DIMENSIONS SHOWN FOR PLACEMENT OF ELASTOMERIC CONCRETE.

PROJECT NO. I-5501
 HENDERSON COUNTY
 STATION: 25+83.78 -L-

SHEET 7 OF 7

STATE OF NORTH CAROLINA
 DEPARTMENT OF TRANSPORTATION
 RALEIGH

FOAM JOINT DETAILS

REVISIONS						SHEET NO.
NO.	BY:	DATE:	NO.	BY:	DATE:	S-7
1			3			TOTAL SHEETS
2			4			7

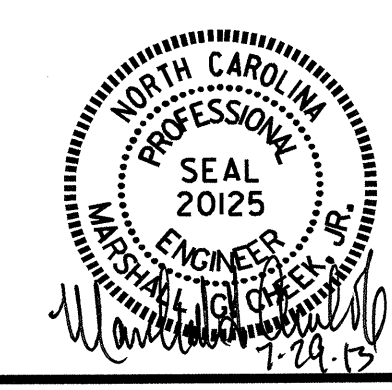

DRAWN BY: W.J. HARRIS DATE: 3/20/13
 CHECKED BY: M.G. CHEEK DATE: 5/13

BM-1 NCGS MONUMENT "AIRPORT" -L- STA. 15+03.00 40' LEFT
 EL. = 2159.27' N 632770 E 946772

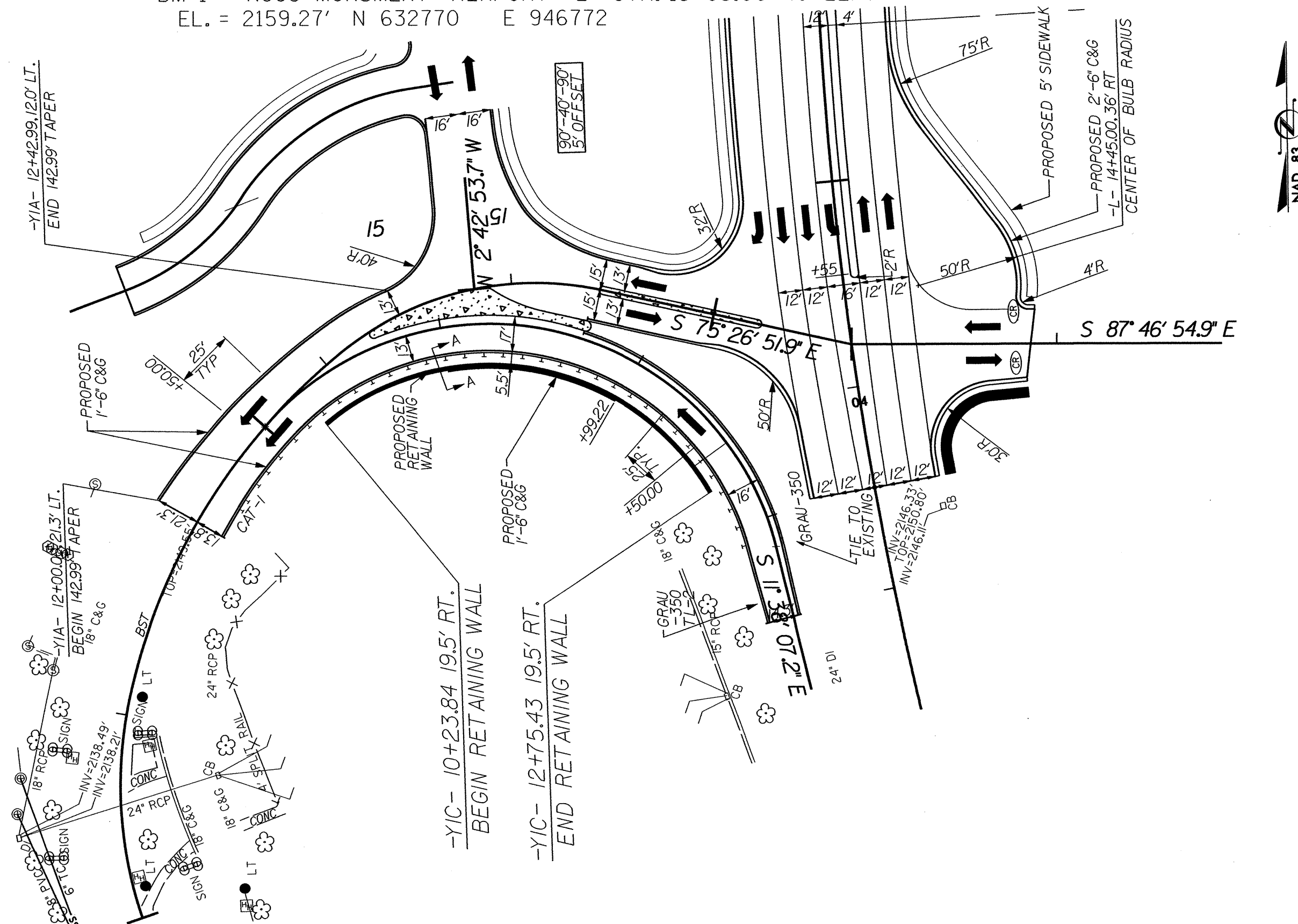

LOCATION SKETCH

TOTAL STRUCTURE QUANTITIES
 PRECAST GRAVITY RETAINING WALL 1359.0 SQ. FT.

GEOTECHNICAL ENGINEER
 ENGINEER

SEAL 29869
 ENGINEER
 SHANE C. CLARK

Signature: S. C. Clark Date: 7/27/17

RETAINING WALL ELEVATIONS

-WALL1- STA	OFFSET FROM C (LEFT)	ELEV @ TOP OF WALL	* PROPOSED FINISHED GRADE	* EXPOSED WALL HEIGHT	** DESIGN WALL HEIGHT "H"
10+00.00	19.50	2153.78'	2153.78'	0.00	0.00
10+29.19	19.50	2,154.18'	2,153.74'	0.55	0.05
10+61.63	19.50	2,155.29'	2,147.67'	7.67	7.17
11+00.46	19.50	2,156.10'	2,145.77'	10.33	9.83
11+38.72	19.50	2,156.13'	2,145.19'	10.94	10.44
11+73.92	19.50	2,155.49'	2,149.65'	5.84	5.34
11+95.42	19.50	2,154.71'	2,152.22'	2.50	2.00
12+17.52	19.50	2,153.63'	2,153.63'	0.00	0.00

* ELEVATION @ PROPOSED FINISHED GRADE AND EXPOSED WALL HEIGHT DO NOT INCLUDE EMBEDMENT DEPTH
 ** FOR DESIGN WALL HEIGHT "H", SEE THE PRECAST GRAVITY RETAINING WALL DETAILS ON SHEET 1 OF 2.

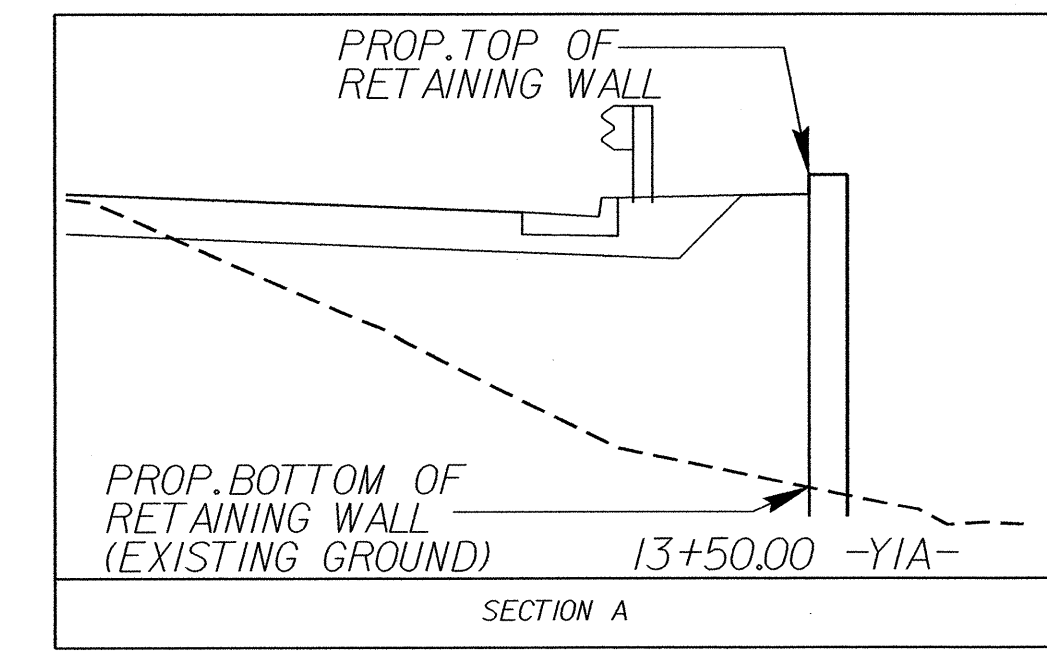
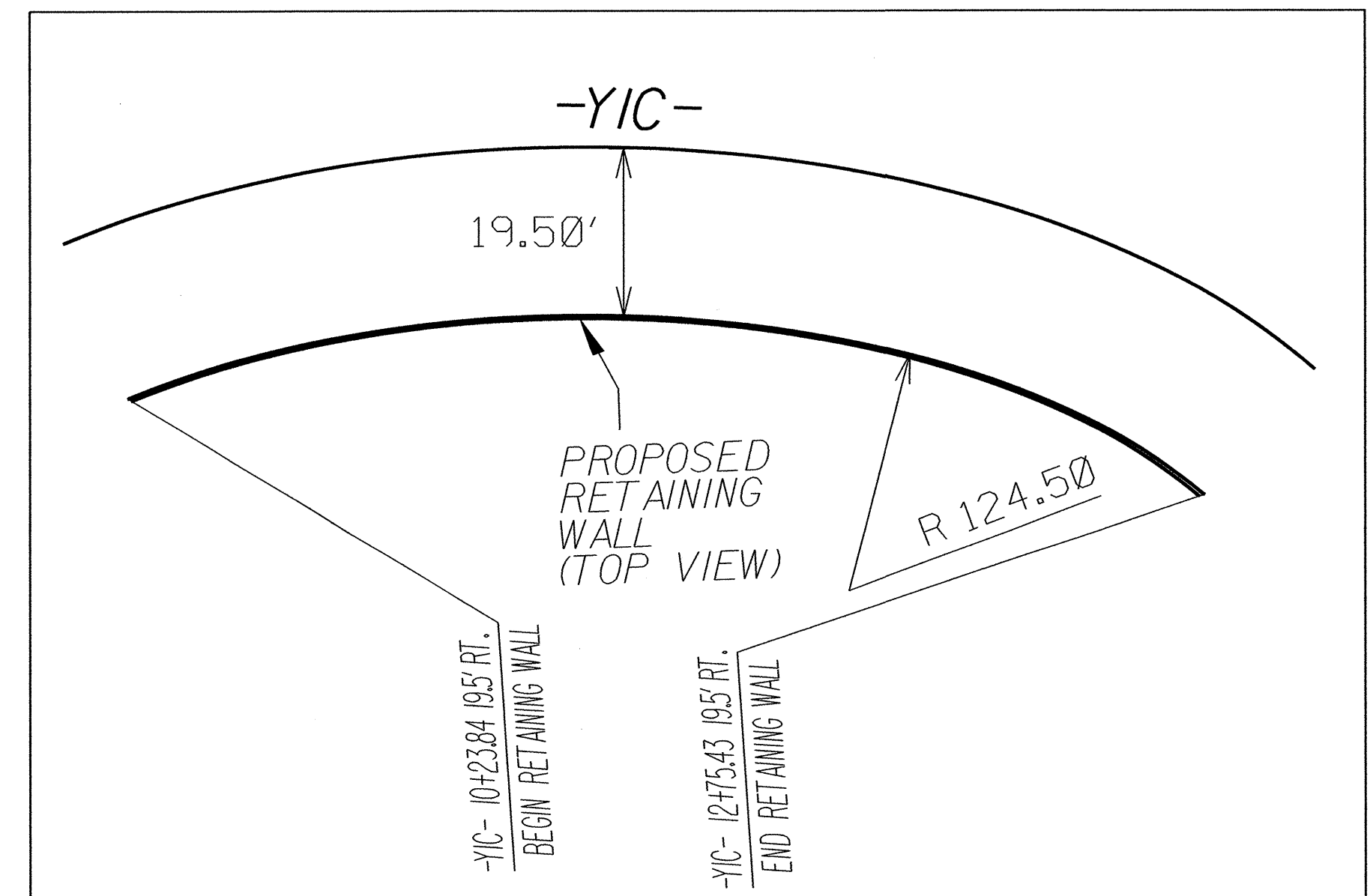
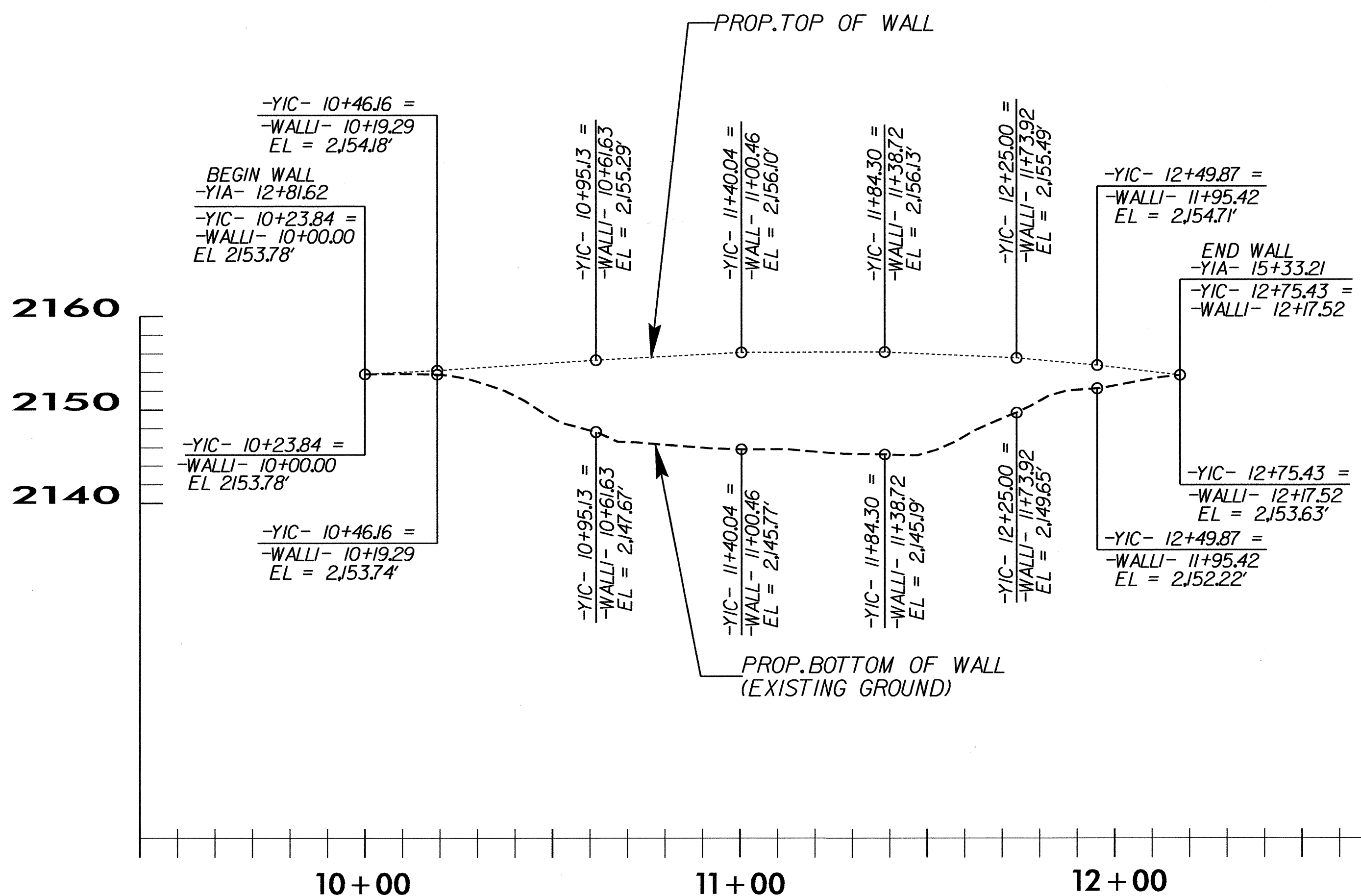

PROJECT NO.: I-5501
 BUNCOMBE COUNTY
 STATION: -YIC- 10+23.84 = -WALL1- 10+00.00 TO -YIC- 12+75.43 = -WALL1- 12+17.52
 SHEET 1 OF 2

PREPARED BY: J.T.W. DATE: 4.13
 REVIEWED BY: S.C.C. DATE: 6.13

GEOTECHNICAL ENGINEERING UNIT

EASTERN REGIONAL OFFICE
 WESTERN REGIONAL OFFICE
 CONTRACT OFFICE

STATE OF NORTH CAROLINA
 DEPARTMENT OF TRANSPORTATION
 RALEIGH

PRECAST GRAVITY RETAINING WALL

REVISIONS						SHEET NO.
NO.	BY	DATE	NO.	BY	DATE	6-1
1			3			TOTAL SHEETS
2			4			2

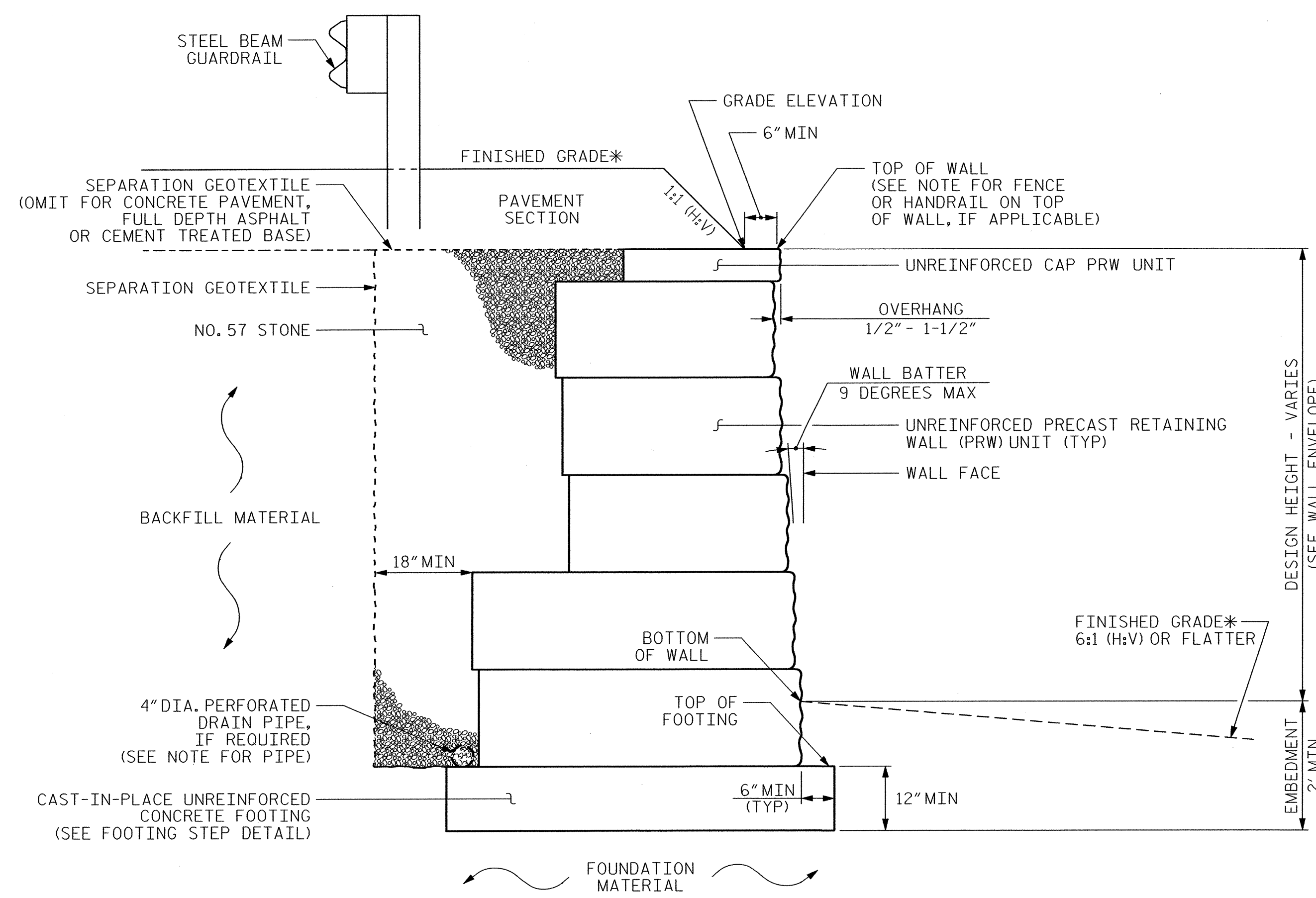

PRECAST GRAVITY WALL WITH CAP PRW UNIT - TYPICAL SECTION

*SEE ROADWAY PLANS FOR FINISHED GRADE DETAILS.

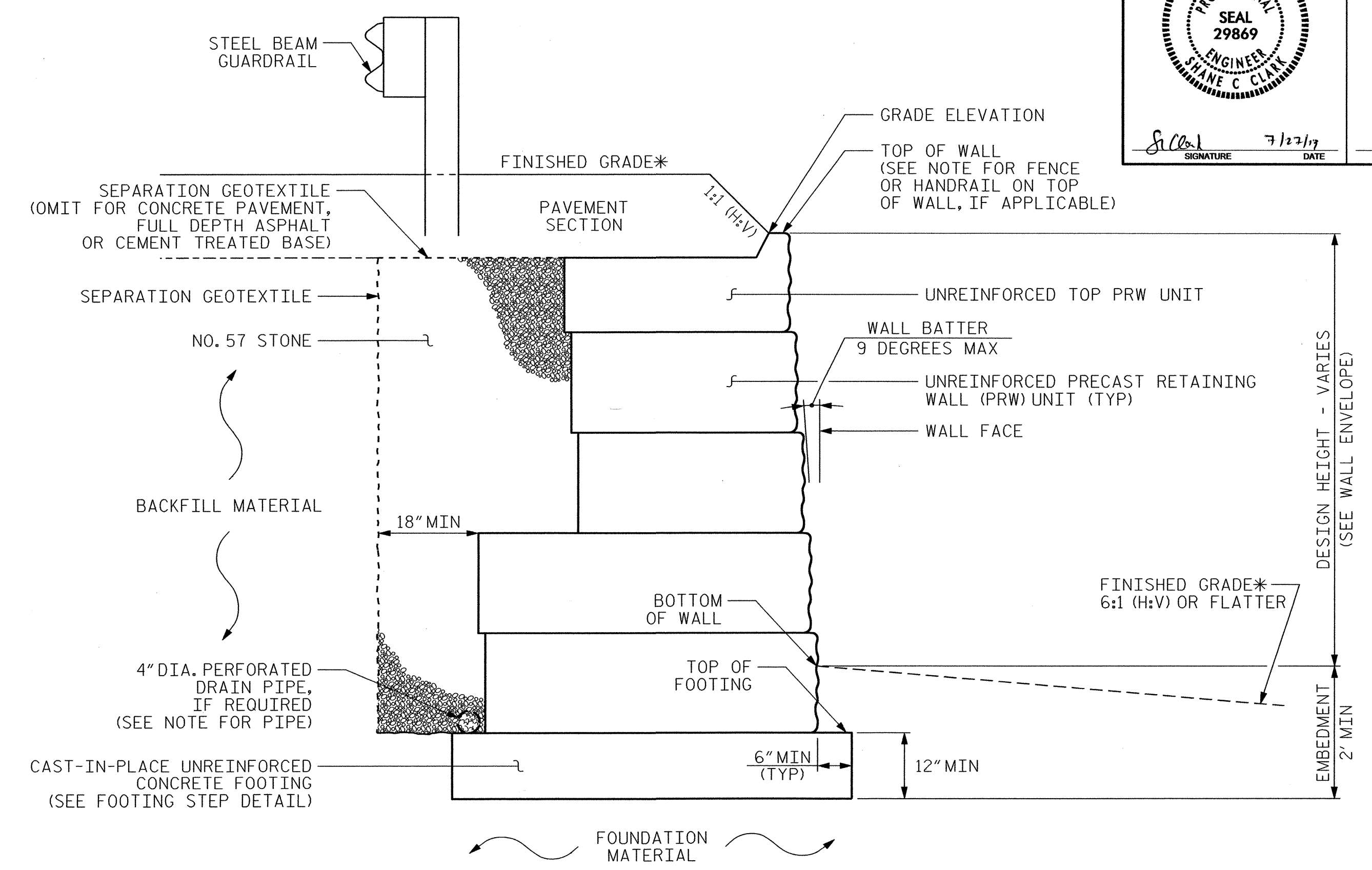

PRECAST GRAVITY WALL WITH TOP PRW UNIT - TYPICAL SECTION

*SEE ROADWAY PLANS FOR FINISHED GRADE DETAILS.

NOTES:

- FOR PRECAST GRAVITY RETAINING WALLS, SEE PRECAST GRAVITY RETAINING WALLS PROVISION.
- FOR STEEL BEAM GUARDRAIL, SEE ROADWAY PLANS AND SECTION 862 OF THE STANDARD SPECIFICATIONS.
- USE PRW UNITS WITH AN ANGULAR ROCK FACE FOR RETAINING.
- USE PRW UNITS WITH A GRAY COLOR FOR RETAINING WALL.
- A DRAIN PIPE IS REQUIRED FOR RETAINING WALL.

- DESIGN RETAINING WALL FOR A LIVE LOAD (TRAFFIC) SURCHARGE.
- DO NOT PLACE CONCRETE FOR FOOTINGS FOR RETAINING WALL UNTIL EXCAVATION DIMENSIONS AND FOUNDATION MATERIAL ARE APPROVED.
- AT THE CONTRACTOR'S OPTION, "TEMPORARY SHORING FOR WALL CONSTRUCTION" MAY BE USED TO CONSTRUCT RETAINING WALL. SEE PRECAST GRAVITY RETAINING WALLS PROVISION FOR TEMPORARY SHORING FOR WALL CONSTRUCTION.

BEFORE BEGINNING PRECAST GRAVITY WALL DESIGN FOR RETAINING WALL, SURVEY WALL LOCATION AND SUBMIT A REVISED WALL PROFILE VIEW (WALL ENVELOPE) FOR REVIEW. DO NOT START WALL DESIGN OR CONSTRUCTION UNTIL THE REVISED WALL ENVELOPE IS ACCEPTED.

DESIGN RETAINING WALL FOR WALL HEIGHTS EQUAL TO THE DESIGN HEIGHT PLUS DEPTH TO TOP OF FOOTING (DIFFERENCE BETWEEN GRADE ELEVATION AND TOP OF FOOTING ELEVATION).

- DESIGN RETAINING WALL FOR THE FOLLOWING:
- 1) MAXIMUM FACTORED VERTICAL STRESS ON FOUNDATION MATERIAL = 3000 LB/SF
 - 2) MINIMUM EMBEDMENT ELEVATION = 2 FT
 - 3) IN-SITU ASSUMED MATERIAL PARAMETERS:

MATERIAL TYPE	UNIT WEIGHT (γ) LB/CF	FRICTION ANGLE (φ) DEGREES	COHESION (c) LB/SF
BACKFILL	120	30	0
FOUNDATION	120	30	0

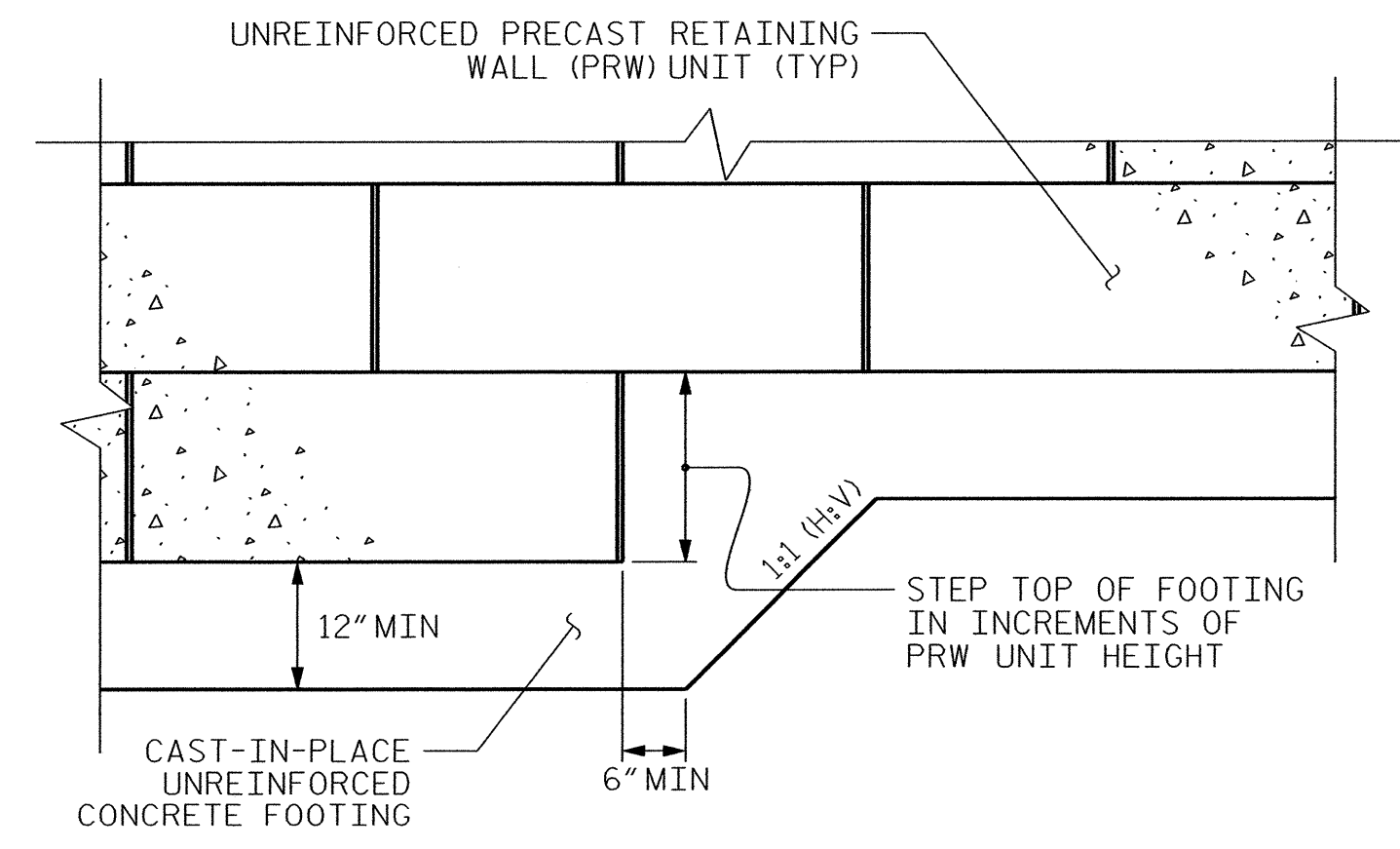

FOOTING STEP DETAIL

PROJECT NO.: I-5501
 BUNCOMBE COUNTY
 STATION: -Y1C- 10+23.84 = -WALL1- 10+00.00 TO
 -Y1C- 12+75.43 = -WALL1- 12+17.52
 SHEET 2 OF 2

GEOTECHNICAL ENGINEERING UNIT
 EASTERN REGIONAL OFFICE
 WESTERN REGIONAL OFFICE
 CONTRACT OFFICE
 STATE OF NORTH CAROLINA
 DEPARTMENT OF TRANSPORTATION
 RALEIGH

PRECAST GRAVITY RETAINING WALL DETAILS

REVISIONS						SHEET NO.
NO.	BY	DATE	NO.	BY	DATE	TOTAL SHEETS
1			3			2
2			4			2

STANDARD NOTES

DESIGN DATA:

SPECIFICATIONS	-----	A.A.S.H.T.O. (CURRENT)
LIVE LOAD	-----	SEE PLANS
IMPACT ALLOWANCE	-----	SEE A.A.S.H.T.O.
STRESS IN EXTREME FIBER OF		
STRUCTURAL STEEL - AASHTO M270 GRADE 36	-	20,000 LBS. PER SQ. IN.
- AASHTO M270 GRADE 50W	-	27,000 LBS. PER SQ. IN.
- AASHTO M270 GRADE 50	-	27,000 LBS. PER SQ. IN.
REINFORCING STEEL IN TENSION		
GRADE 60	--	24,000 LBS. PER SQ. IN.
CONCRETE IN COMPRESSION	-----	1,200 LBS. PER SQ. IN.
CONCRETE IN SHEAR	-----	SEE A.A.S.H.T.O.
STRUCTURAL TIMBER - TREATED OR		
UNTREATED - EXTREME FIBER STRESS	-----	1,800 LBS. PER SQ. IN.
COMPRESSION PERPENDICULAR TO GRAIN OF TIMBER	-----	375 LBS. PER SQ. IN.
EQUIVALENT FLUID PRESSURE OF EARTH	-----	30 LBS. PER CU. FT. (MINIMUM)

MATERIAL AND WORKMANSHIP:

EXCEPT AS MAY OTHERWISE BE SPECIFIED ON PLANS OR IN THE SPECIAL PROVISIONS, ALL MATERIAL AND WORKMANSHIP SHALL BE IN ACCORDANCE WITH THE 2012 "STANDARD SPECIFICATIONS FOR ROADS AND STRUCTURES" OF THE N.C. DEPARTMENT OF TRANSPORTATION.

STEEL SHEET PILING FOR PERMANENT OR TEMPORARY APPLICATIONS SHALL BE HOT ROLLED.

CONCRETE:

UNLESS OTHERWISE REQUIRED ON PLANS, CLASS A CONCRETE SHALL BE USED FOR ALL PORTIONS OF ALL STRUCTURES WITH THE EXCEPTION THAT: CLASS AA CONCRETE SHALL BE USED IN BRIDGE SUPERSTRUCTURES, ABUTMENT BACKWALLS, AND APPROACH SLABS; AND CLASS B CONCRETE SHALL BE USED FOR SLOPE PROTECTION AND RIP RAP.

CONCRETE CHAMFERS:

UNLESS OTHERWISE NOTED ON THE PLANS, ALL EXPOSED CORNERS ON STRUCTURES SHALL BE CHAMFERED 3/4" WITH THE FOLLOWING EXCEPTIONS: TOP CORNERS OF CURBS MAY BE ROUNDED TO 1-1/2" RADIUS WHICH IS BUILT INTO CURB FORMS; CORNERS OF TRANSVERSE FLOOR EXPANSION JOINTS SHALL BE ROUNDED WITH A 1/4" FINISHING TOOL UNLESS OTHERWISE REQUIRED ON PLANS; AND CORNERS OF EXPANSION JOINTS IN THE ROADWAY FACES AND TOPS OF CURBS AND SIDEWALKS SHALL BE ROUNDED TO A 1/4" RADIUS WITH A FINISHING STONE OR TOOL UNLESS OTHERWISE REQUIRED ON PLANS.

DOWELS:

DOWELS WHEN INDICATED ON PLANS AS FOR CULVERT EXTENSIONS, SHALL BE EMBEDDED AT LEAST 12" INTO THE OLD CONCRETE AND GROUTED INTO PLACE WITH 1:2 CEMENT MORTAR.

ALLOWANCE FOR DEAD LOAD DEFLECTION, SETTLEMENT,
ETC. IN CASTING SUPERSTRUCTURES:

BRIDGES SHALL BE BUILT ON THE GRADE OR VERTICAL CURVE SHOWN ON PLANS. SLABS, CURBS AND PARAPETS SHALL CONFORM TO THE GRADE OR CURVE. ALL DIMENSIONS WHICH ARE GIVEN IN SECTION AND ARE AFFECTED BY DEAD LOAD DEFLECTIONS ARE DIMENSIONS AT CENTER LINE OF BEARING UNLESS OTHERWISE NOTED ON PLANS. IN SETTING FORMS FOR STEEL BEAM BRIDGES AND PRESTRESSED CONCRETE GIRDER BRIDGES, ADJUSTMENTS SHALL BE MADE DUE TO THE DEAD LOAD DEFLECTIONS FOR THE ELEVATIONS SHOWN. WHERE BLOCKS ARE SHOWN OVER BEAMS FOR BUILDING UP TO THE SLAB, THE VERTICAL DIMENSIONS OF THE BLOCKS SHALL BE ADJUSTED BETWEEN BEARINGS TO COMPENSATE FOR DEAD LOAD DEFLECTIONS, VERTICAL CURVE ORDINATE, AND ACTUAL BEAM CAMBER. WHERE BOTTOM OF SLAB IS IN LINE WITH BOTTOM OF TOP FLANGES, DEPTH OF SLAB BETWEEN BEARINGS SHALL BE ADJUSTED TO COMPENSATE FOR DEAD LOAD DEFLECTION, VERTICAL CURVE ORDINATE, AND ACTUAL BEAM CAMBER.

IN SETTING FALSEWORK AND FORMS FOR REINFORCED CONCRETE SPANS, AN ALLOWANCE SHALL BE MADE FOR DEAD LOAD DEFLECTIONS, SETTLEMENT OF FALSEWORK, AND PERMANENT CAMBER WHICH SHALL BE PROVIDED FOR IN ADDITION TO THE ELEVATIONS SHOWN. AFTER REMOVAL OF THE FALSEWORK, THE FINISHED STRUCTURES SHALL CONFORM TO THE PROFILE AND ELEVATIONS SHOWN ON THE PLANS AND CONSTRUCTION ELEVATIONS FURNISHED BY THE ENGINEER. DETAILED DRAWINGS FOR FALSEWORK OR FORMS FOR BRIDGE SUPERSTRUCTURE AND ANY STRUCTURE OR PARTS OF A STRUCTURE AS NOTED ON THE PLANS SHALL BE SUBMITTED TO THE ENGINEER FOR APPROVAL BEFORE CONSTRUCTION OF THE FALSEWORK OR FORMS IS STARTED.

REINFORCING STEEL:

ALL REINFORCING STEEL SHALL BE DEFORMED. DIMENSIONS RELATIVE TO PLACEMENT OF REINFORCING ARE TO CENTERS OF BARS UNLESS OTHERWISE INDICATED IN THE PLANS. DIMENSIONS ON BAR DETAILS ARE TO CENTERS OF BARS OR ARE OUT TO OUT AS INDICATED ON PLANS. WIRE BAR SUPPORTS SHALL BE PROVIDED FOR REINFORCING STEEL WHERE INDICATED ON THE PLANS. WHEN BAR SUPPORT PIECES ARE PLACED IN CONTINUOUS LINES, THEY SHALL BE SO PLACED THAT THE ENDS OF THE SUPPORTING WIRES SHALL BE LAPPED TO LOCK LEGS ON ADJOINING PIECES.

STRUCTURAL STEEL:

AT THE CONTRACTOR'S OPTION, HE MAY SUBSTITUTE 7/8" Ø SHEAR STUDS FOR THE 3/4" Ø STUDS SPECIFIED ON THE PLANS. THIS SUBSTITUTION SHALL BE MADE AT THE RATE OF 3 - 7/8" Ø STUDS FOR 4 - 3/4" Ø STUDS, AND STUD SPACING CHANGES SHALL BE MADE AS NECESSARY TO PROVIDE THE SAME EQUIVALENT NUMBER OF 7/8" Ø STUDS ALONG THE BEAM AS SHOWN FOR 3/4" Ø STUDS BASED ON THE RATIO OF 3 - 7/8" Ø STUDS FOR 4 - 3/4" Ø STUDS. STUDS OF THE LENGTH SPECIFIED ON THE PLANS MUST BE PROVIDED. THE MAXIMUM SPACING SHALL BE 2'-0". EXCEPT AT THE INTERIOR SUPPORTS OF CONTINUOUS BEAMS WHERE THE COVER PLATE IS IN CONTACT WITH BEARING PLATE, THE CONTRACTOR MAY, AT HIS OPTION, SUBSTITUTE FOR THE COVER PLATES DESIGNATED ON THE PLANS COVER PLATES OF THE EQUIVALENT AREA PROVIDED THESE PLATES ARE AT LEAST 5/16" IN THICKNESS AND DO NOT EXCEED A WIDTH EQUAL TO THE FLANGE WIDTH LESS 2" OR A THICKNESS EQUAL TO 2 TIMES THE FLANGE THICKNESS. THE SIZE OF FILLET WELDS SHALL CONFORM TO THE REQUIREMENTS OF THE CURRENT ANSI/AASHTO/AWS "BRIDGE WELDING CODE". ELECTROSLAG WELDING WILL NOT BE PERMITTED. WITH THE SOLE EXCEPTION OF EDGES AT SURFACES WHICH BEAR ON OTHER SURFACES, ALL SHARP EDGES AND ENDS OF SHAPES AND PLATES SHALL BE SLIGHTLY ROUNDED BY SUITABLE MEANS TO A RADIUS OF APPROXIMATELY 1/16 INCH OR EQUIVALENT FLAT SURFACE AT A SUITABLE ANGLE PRIOR TO PAINTING, GALVANIZING, OR METALLIZING.

HANDRAILS AND POSTS:

METAL STANDARDS AND FACES OF THE CONCRETE END POSTS FOR THE METAL RAIL SHALL BE SET NORMAL TO THE GRADE OF THE CURB, UNLESS OTHERWISE SHOWN ON PLANS. THE METAL RAIL AND TOPS OF CONCRETE POSTS USED WITH THE ALUMINUM RAIL SHALL BE BUILT PARALLEL TO THE GRADE OF THE CURB. METAL HANDRAILS SHALL BE IN ACCORDANCE WITH THE PLANS. RAILS SHALL BE AS MANUFACTURED FOR BRIDGE RAILING. CASTINGS SHALL BE OF A UNIFORM APPEARANCE. FINIS AND OTHER DEFORMATIONS RESULTING FROM CASTING OR OTHERWISE SHALL BE REMOVED IN A MANNER SO THAT A UNIFORM COLORING OF THE COMPLETED CASTING SHALL BE OBTAINED. CASTINGS WITH DISCOLORATIONS OR OF NON-UNIFORM COLORING WILL NOT BE ACCEPTED. CERTIFIED MILL REPORTS ARE REQUIRED FOR METAL RAILS AND POSTS.

SPECIAL NOTES:

GENERALLY, IN CASE OF DISCREPANCY, THIS STANDARD SHEET OF NOTES SHALL GOVERN OVER THE SPECIFICATIONS, BUT THE REMAINDER OF THE PLANS SHALL GOVERN OVER NOTES HEREON, AND SPECIAL PROVISIONS SHALL GOVERN OVER ALL. SEE SPECIFICATIONS ARTICLE 105-4.

ENGLISH
JANUARY, 1990