

T.I.P.: R-3421C

CONTRACT:

**STATE OF NORTH CAROLINA
DEPARTMENT OF TRANSPORTATION**

TIP NO. R-3421C	SHEET NO. PMP-1
APPROVED: <i>[Signature]</i>	
DATE: 10.22.15	
SEAL	
	

**PAVEMENT MARKING PLAN
RICHMOND COUNTY**

**LOCATION: US 220 BYPASS FROM 0.2 MILES SOUTHWEST OF
SR 1304 (HARRINGTON RD) TO US 220 BUSINESS/BYPASS
INTERCHANGE SOUTH OF ELLERBE**

Part 2 of 2

ROADWAY STANDARD DRAWINGS

THE FOLLOWING ROADWAY STANDARDS AS APPEAR IN "ROADWAY STANDARD DRAWINGS" - PROJECT SERVICES UNIT - N.C. DEPARTMENT OF TRANSPORTATION - RALEIGH, N.C., DATED JANUARY 2012 ARE APPLICABLE TO THIS PROJECT AND BY REFERENCE HEREBY ARE CONSIDERED A PART OF THESE PLANS:

STD. NO.	TITLE
1205.01	PAVEMENT MARKINGS - LINE TYPES AND OFFSETS
1205.02	PAVEMENT MARKINGS - 2 LANE AND MULTI LANE ROADWAYS
1205.04	PAVEMENT MARKINGS - INTERSECTIONS
1205.05	PAVEMENT MARKINGS - TURN LANES
1205.06	PAVEMENT MARKINGS - LANE DROPS
1205.09	PAVEMENT MARKINGS - PAINTED ISLANDS
1205.12	PAVEMENT MARKINGS - BRIDGES
1250.01	RAISED PAVEMENT MARKERS - INSTALLATION SPACING
1251.01	RAISED PAVEMENT MARKERS - PERMANENT & TEMPORARY
1253.01	RAISED PAVEMENT MARKERS - SNOWPLOWABLE
1261.02	GUARDRAIL AND BARRIER DELINEATORS - TYPES & MOUNTING
1262.01	GUARDRAIL END DELINEATION
1264.01	OBJECT MARKERS - TYPES
1264.02	OBJECT MARKERS - INSTALLATION
1267.01	FLEXIBLE DELINEATORS - INSTALLATION
1267.02	FLEXIBLE DELINEATORS - SPACING TABLES
1267.03	FLEXIBLE DELINEATORS - INTERCHANGE PLACEMENT

INDEX

SHEET NO.	DESCRIPTION
PMP-1	PAVEMENT MARKING PLAN COVER SHEET
PMP-1A	PAVEMENT MARKING LEGEND & SCHEDULE
PMP-1B	DETAIL DRAWING FOR PAVEMENT MARKINGS - LANE DROPS (REPLACEMENT FOR RSD 1205.06 SHEET 1 OF 3)
PMP-02 THRU PMP-21	PAVEMENT MARKING DETAILS

ALTERNATIVE CONCRETE DESIGN NOTE:

IF CONCRETE IS USED ON MAINLINE, PLACE POLYUREA PAVEMENT MARKINGS WITH HIGHLY REFLECTIVE ELEMENTS AFTER REMOVING CURING COMPOUND AND SURFACE LAITANCE ON ALL CONCRETE SURFACES INCLUDING BRIDGE DECKS ON Y-LINES.

GENERAL NOTES

THE FOLLOWING GENERAL NOTES APPLY AT ALL TIMES FOR THE DURATION OF THE CONSTRUCTION PROJECT, EXCEPT WHEN OTHERWISE NOTED IN THE PLAN, OR DIRECTED BY THE ENGINEER.

A) INSTALL PAVEMENT MARKINGS AND PAVEMENT MARKERS ON THE FINAL SURFACE AS FOLLOWS:

ROAD NAME	MARKING	MARKER
US 220 (-L-)	THERMOPLASTIC	SNOWPLOWABLE
ALL OTHER ROADS	THERMOPLASTIC	MATCH EXISTING
BRIDGES	POLYUREA W/ HIGHLY REFLECTIVE ELEMENTS	RAISED

B) ON ASPHALT SURFACES USE HEATED-IN-PLACE THERMOPLASTIC OR EXTRUDED THERMOPLASTIC MARKINGS FOR STOP BARS, SYMBOLS, CHARACTERS AND DIAGONALS.

C) REMOVE ALL RESIDUE AND SURFACE LAITANCE BY WATER BLASTING OR GRINDING ON BRIDGE DECK(S) PRIOR TO PLACING POLYUREA PAVEMENT MARKINGS.

D) TIE PROPOSED PAVEMENT MARKING LINES TO EXISTING PAVEMENT MARKING LINES.

E) REMOVE/REPLACE ANY CONFLICTING/DAMAGED PAVEMENT MARKINGS AND MARKERS THAT HAVE BEEN DAMAGED BY THE END OF EACH DAY'S OPERATION.

F) PASSING ZONE(S) WILL BE DETERMINED IN THE FIELD AND MUST BE APPROVED BY THE ENGINEER.

G) MARKERS SHALL BE INSTALLED ACCORDING TO THE NCDOT ROADWAY STANDARD DRAWING 1250.01.

H) STOPBAR LOCATIONS AT NON-SIGNALIZED INTERSECTIONS MAY BE ADJUSTED AS DIRECTED BY THE ENGINEER.

FLEXIBLE DELINEATOR NOTE

INSTALL FLEXIBLE DELINEATORS ALONG THE LEFT SIDE OF LOOPS AND RIGHT SIDE OF RAMPS. ORIENT DELINEATORS FOR MAXIMUM VISIBILITY FOR APPROACHING VEHICLES. REFER TO ROADWAY STANDARD DRAWINGS FOR SPACING AND PLACEMENT.

PLAN REVIEWED BY: N.C.D.O.T. SIGNING AND DELINEATION UNIT

<u>S. Kunz</u>	SIGNING & DELINEATION REGIONAL ENGINEER
<u>S. Coleman</u>	SIGNING & DELINEATION PROJECT DESIGN ENGINEER

PLAN PREPARED BY: HNTB NORTH CAROLINA

<u>R. B. Early, PE</u>	PROJECT ENGINEER
<u>J. Phillips</u>	PROJECT DESIGNER

HNTB HNTB NORTH CAROLINA, P.C.
343 E. Six Forks Road, Suite 200
Raleigh, North Carolina 27609
C-1554

FINAL PAVEMENT MARKING SCHEDULE

MATERIAL	SYMBOL	DESCRIPTION
PAVEMENT MARKING		
THERMOPLASTIC (4", 90 MILS)		
	TA	WHITE EDGELINE
	TB	YELLOW EDGELINE
THERMOPLASTIC (4", 120 MILS)		
	TD	WHITE MINISKIP
	TE	WHITE SOLID LANE LINE
	TF	YELLOW SKIP
	TI	YELLOW DOUBLE CENTER LINE
POLYUREA (4", HIGHLY REFLECTIVE ELEMENTS)		
	VA	WHITE EDGELINE
	VI	DOUBLE YELLOW CENTER LINE
POLYUREA (6", HIGHLY REFLECTIVE ELEMENTS)		
	V6	WHITE EDGELINE
	V7	YELLOW EDGELINE
	VJ	10' WHITE SKIP
THERMOPLASTIC (6", 90 MILS)		
	T6	WHITE EDGELINE
	T7	YELLOW EDGELINE
THERMOPLASTIC (6", 120 MILS)		
	TJ	WHITE SKIP
	TK	WHITE MINISKIP
	TL	WHITE SOLID LANE LINE
THERMOPLASTIC (8", 90 MILS)		
	TN	WHITE GORELINE
	TO	WHITE DIAGONAL
	TP	YELLOW DIAGONAL
COLD APPLIED PLASTIC (8")		
	CP	YELLOW DIAGONAL
THERMOPLASTIC (24", 120 MILS)		
	T2	WHITE STOP BAR
THERMOPLASTIC SYMBOL (90 MILS)		
	UA	LEFT ARROW
	UB	RIGHT ARROW
	UC	STRAIGHT ARROW
THERMOPLASTIC CHARACTERS (120 MILS)		
	UI	ALPHA-NUMERIC CHARACTER

LEGEND

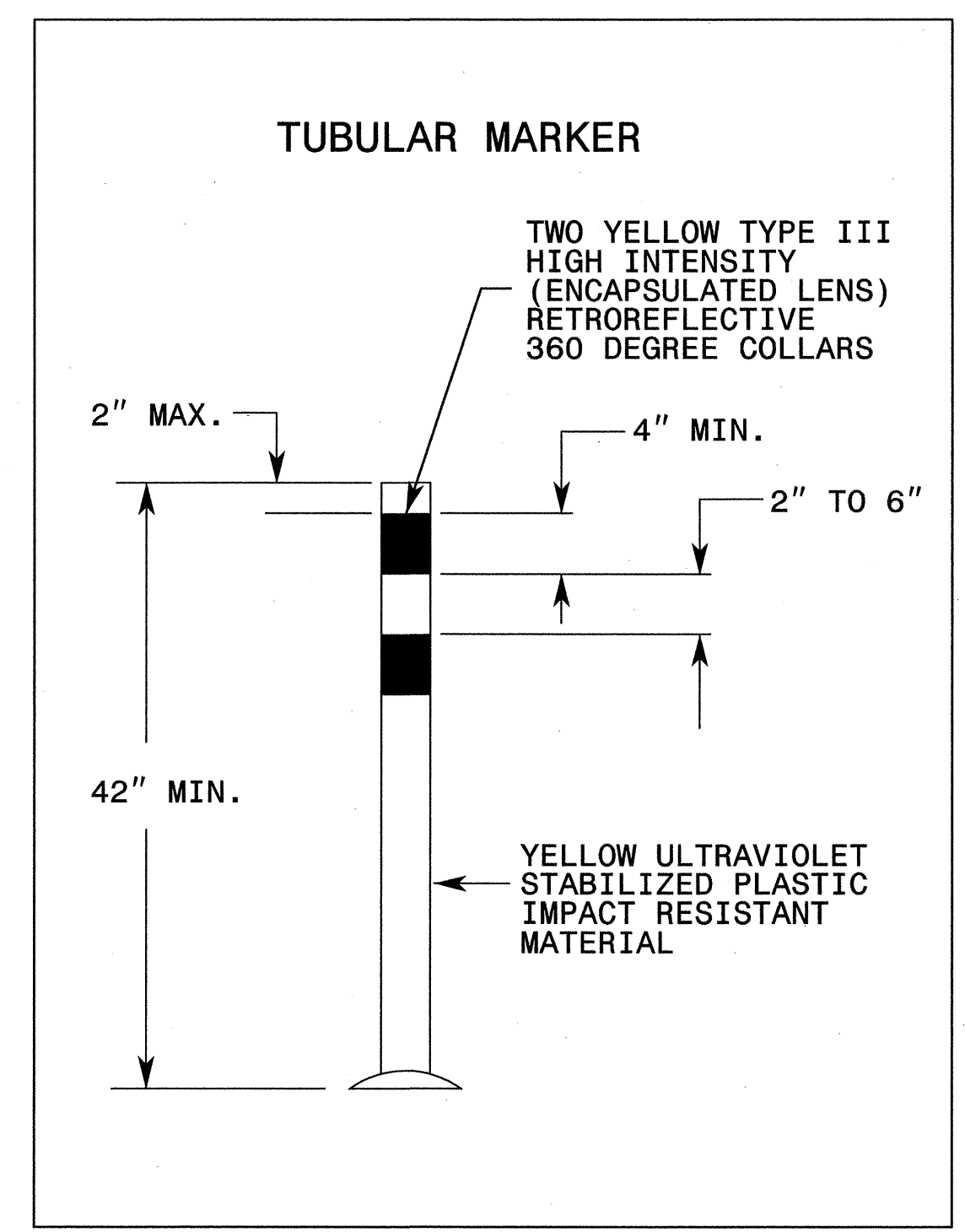
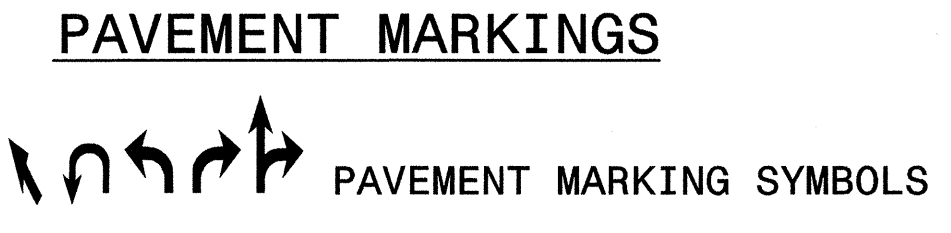
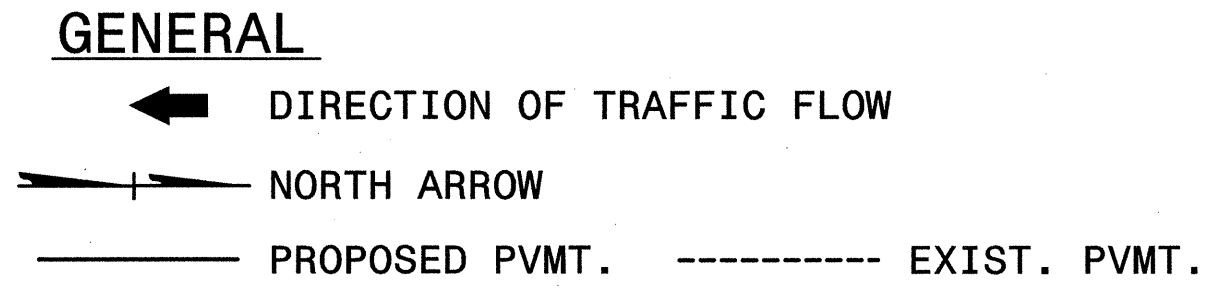

8/17/99

REVISIONS

QA/QC STAGE: _____

REVIEW: RSE 7/26/12

CONCUR: RAC 8/1/12

REVISE: _____

VERIFY: _____

HNTB HNTB NORTH CAROLINA, P.C.
343 E. Six Forks Road, Suite 200
Raleigh, North Carolina 27609
NC License No: C-1554

APPROVED: DATE: 8.7.12

NORTH CAROLINA PROFESSIONAL ENGINEER
 SEAL 023521
 NEVADA B. EARLY

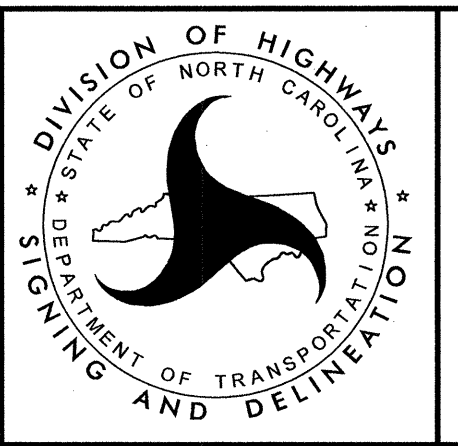

SIGNING AND DELINEATION

FINAL PAVEMENT MARKING PLANS

8/17/99

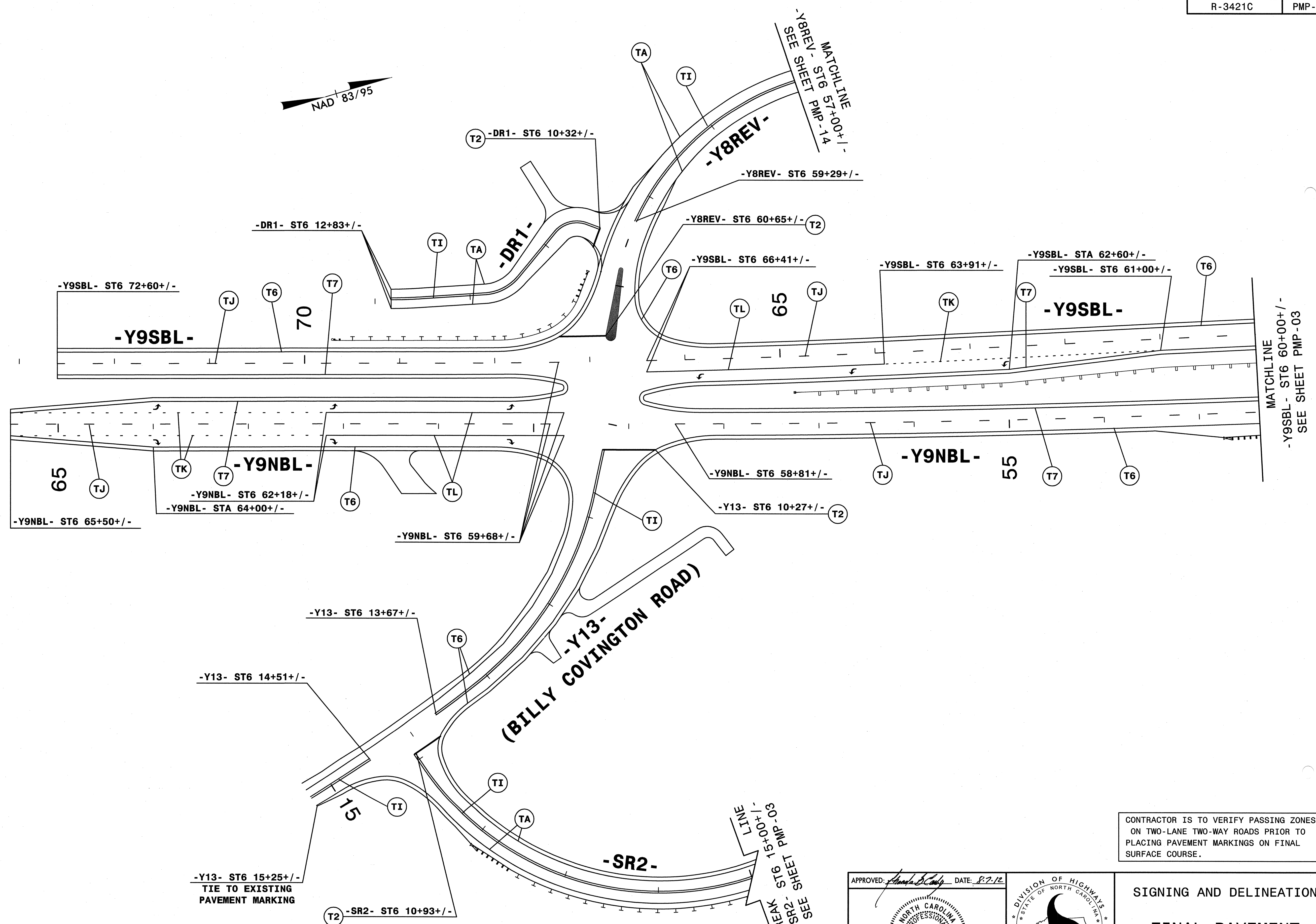
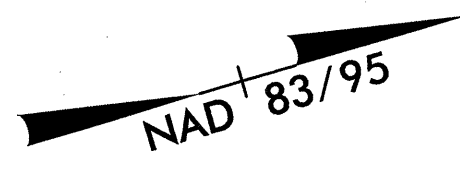

REVISIONS

QA/QC STAGE:	
REVIEW:	RSE 7/26/02
CONCUR:	
REVISE:	RAC 8/17/02
VERIFY:	

SYTIME
CLINS
\$\$\$\$\$

(BILLY COVINGTON ROAD)

BREAK STG 15+00+/-
-SR2-
SEE SHEET PMP-03

-Y13- ST6 15+25+/-
TIE TO EXISTING
PAVEMENT MARKING

CONTRACTOR IS TO VERIFY PASSING ZONES
ON TWO-LANE TWO-WAY ROADS PRIOR TO
PLACING PAVEMENT MARKINGS ON FINAL
SURFACE COURSE.

HNTB
HNTB NORTH CAROLINA, P.C.
3438 E. Six Forks Road, Suite 200
Raleigh, North Carolina 27609
NC License No: C-1554

APPROVED: *[Signature]* DATE: 8-7-02
NORTH CAROLINA
PROFESSIONAL
SEAL
023521
ENGINEER
RYONDA B. EARLY

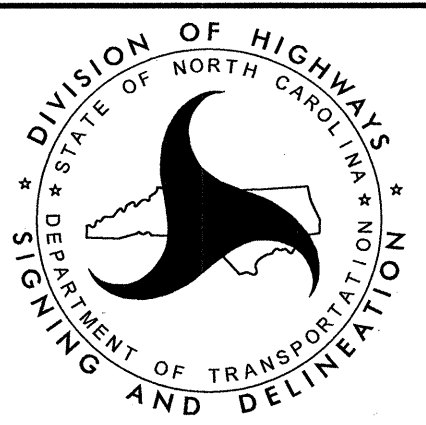

SIGNING AND DELINEATION
**FINAL PAVEMENT
MARKING PLANS**

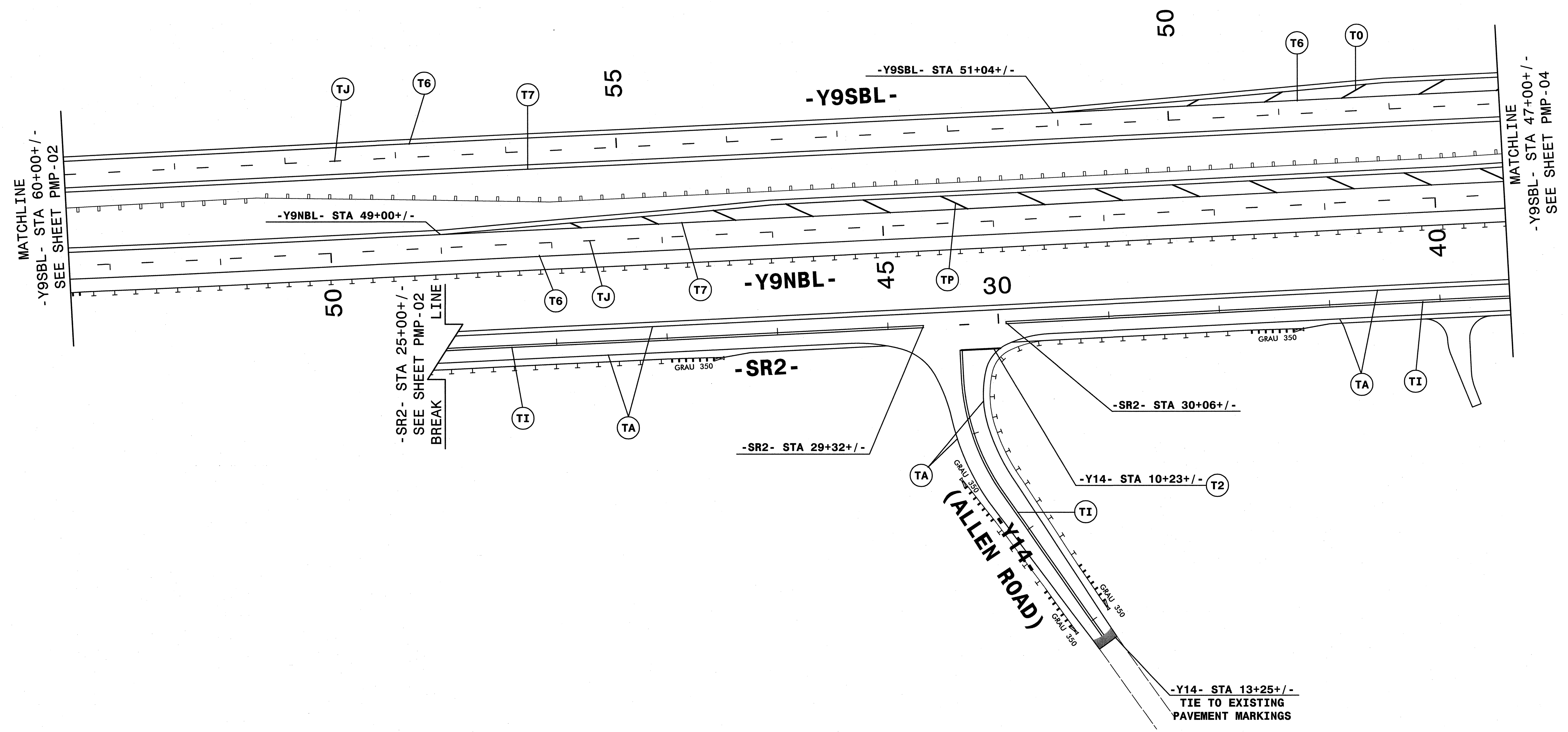
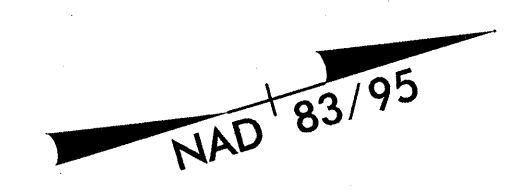

REVISIONS

QA/QC STAGE:	
REVIEW:	RSE 7/26/12
CONCUR:	
REVISE:	RAC 8/1/12
VERIFY:	

CONTRACTOR IS TO VERIFY PASSING ZONES ON TWO-LANE TWO-WAY ROADS PRIOR TO PLACING PAVEMENT MARKINGS ON FINAL SURFACE COURSE.

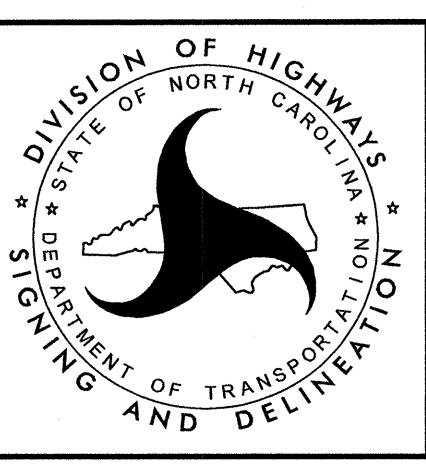
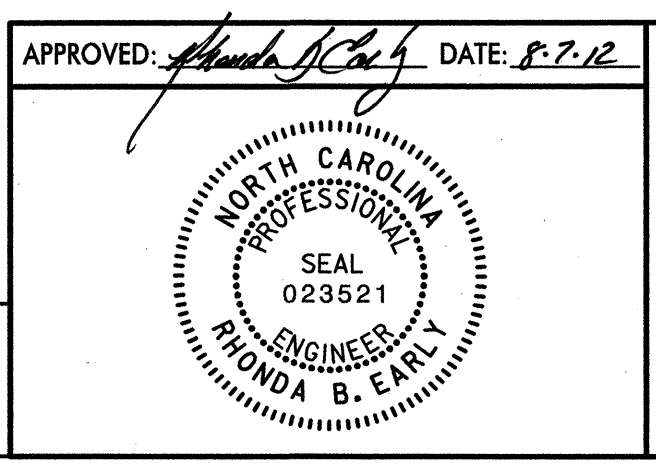
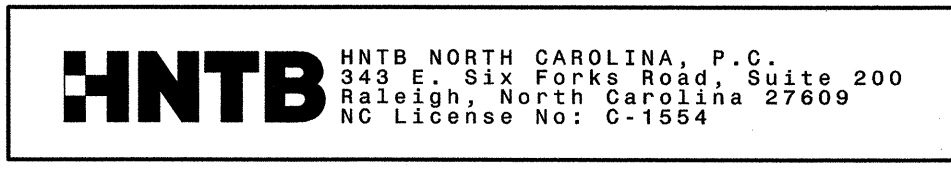

SIGNING AND DELINEATION
FINAL PAVEMENT MARKING PLANS

8/17/99

8/17/99

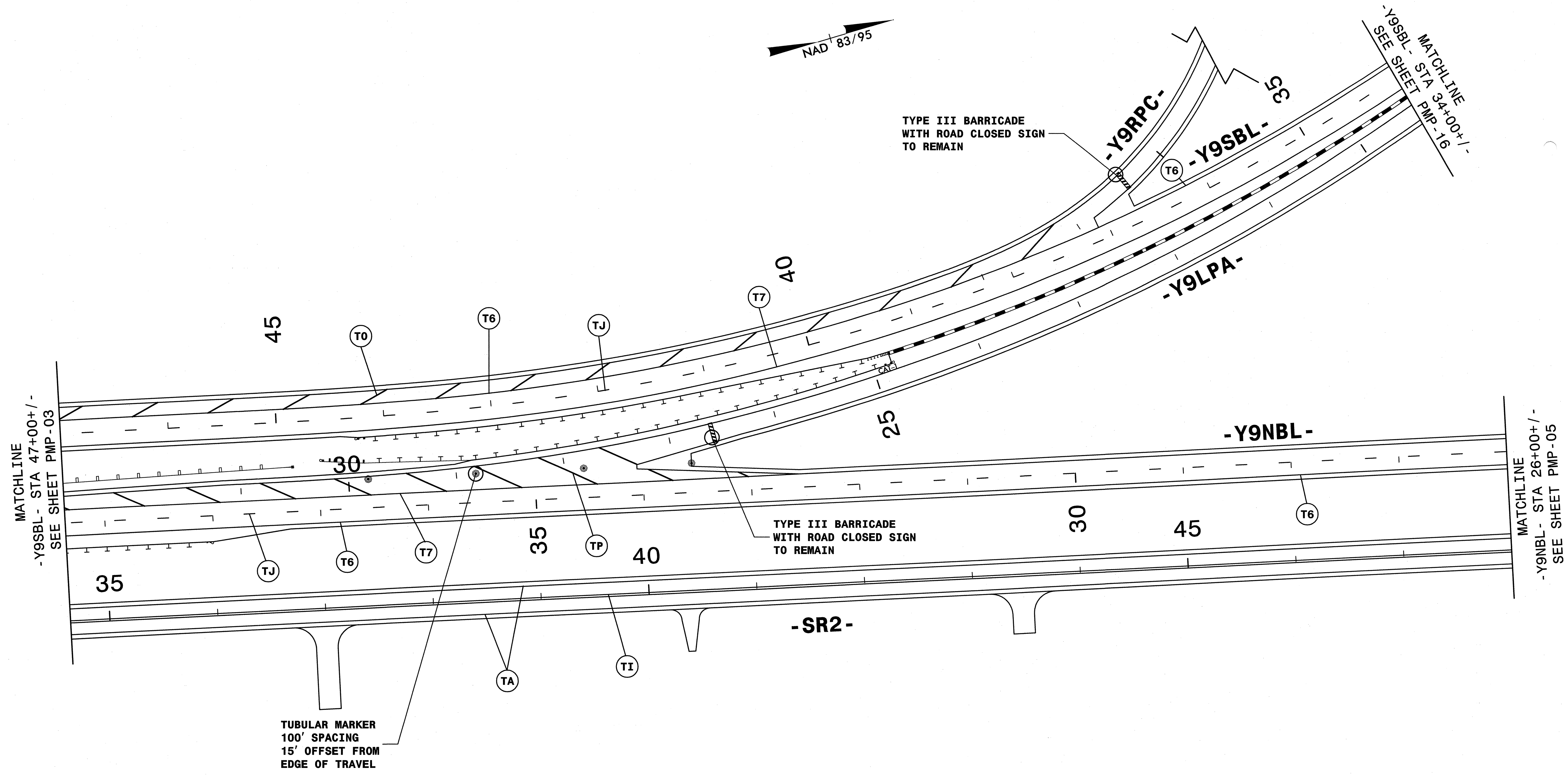

REVISIONS

QA/QC STAGE:	
REVIEW:	RSE 7/26/02
CONCLUR:	
REVISE:	RAC 8/1/02
VERIFY:	

CONTRACTOR IS TO VERIFY PASSING ZONES ON TWO-LANE TWO-WAY ROADS PRIOR TO PLACING PAVEMENT MARKINGS ON FINAL SURFACE COURSE.

HNTB HNTB NORTH CAROLINA, P.C.
 343 E. SIX FORKS ROAD, SUITE 200
 RALEIGH, NORTH CAROLINA 27609
 NC LICENSE NO: C-1554

APPROVED: *[Signature]* DATE: 8.7.02

SEAL
 023521
 ENGINEER
 RHONDA B. EARLY

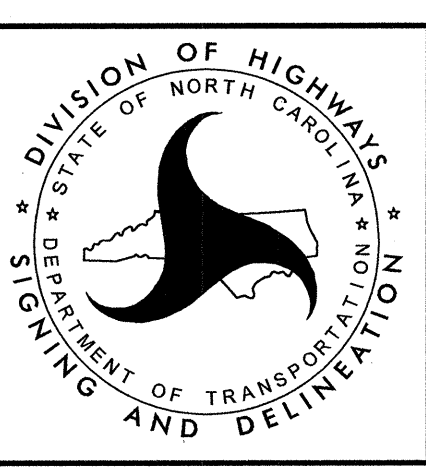

SIGNING AND DELINEATION

FINAL PAVEMENT MARKING PLANS

8/17/99

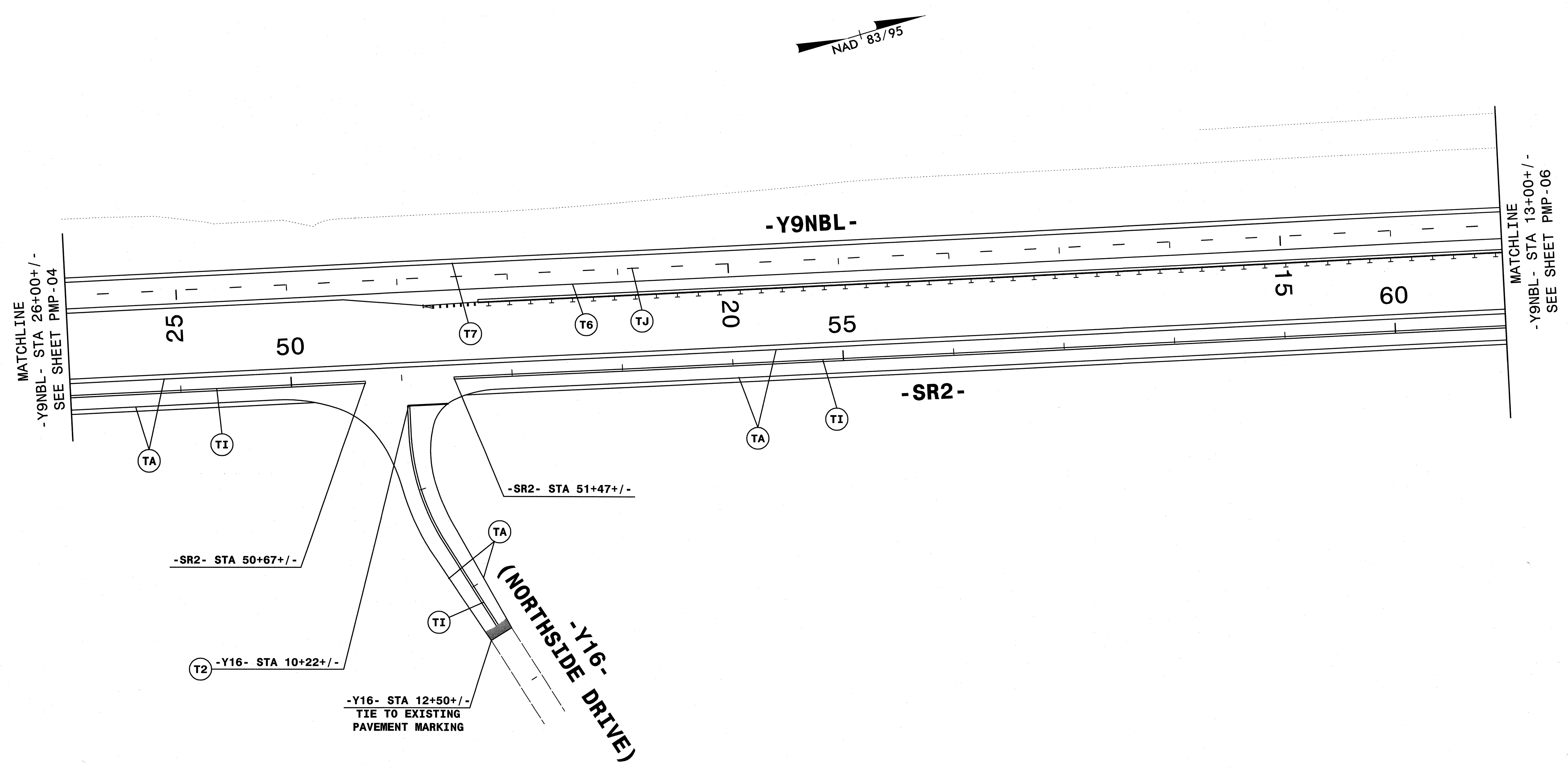

REVISIONS

QA/QC STAGE:	
REVIEW:	RSE 7/26/12
CONCUR:	
REVISE:	RAC 8/11/12
VERIFY:	

CONTRACTOR IS TO VERIFY PASSING ZONES ON TWO-LANE TWO-WAY ROADS PRIOR TO PLACING PAVEMENT MARKINGS ON FINAL SURFACE COURSE.

HNTB
 HNTB NORTH CAROLINA, P.C.
 343 E. Six Forks Road, Suite 200
 Raleigh, North Carolina 27609
 NC License No: C-1554

APPROVED: *[Signature]* DATE: 8-7-12
 NORTH CAROLINA PROFESSIONAL SEAL 023521
 ENGINEER
 BIONDA B. EARLY

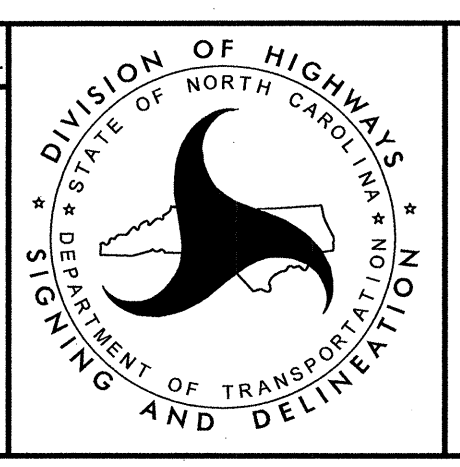

SIGNING AND DELINEATION
FINAL PAVEMENT MARKING PLANS

8/17/99

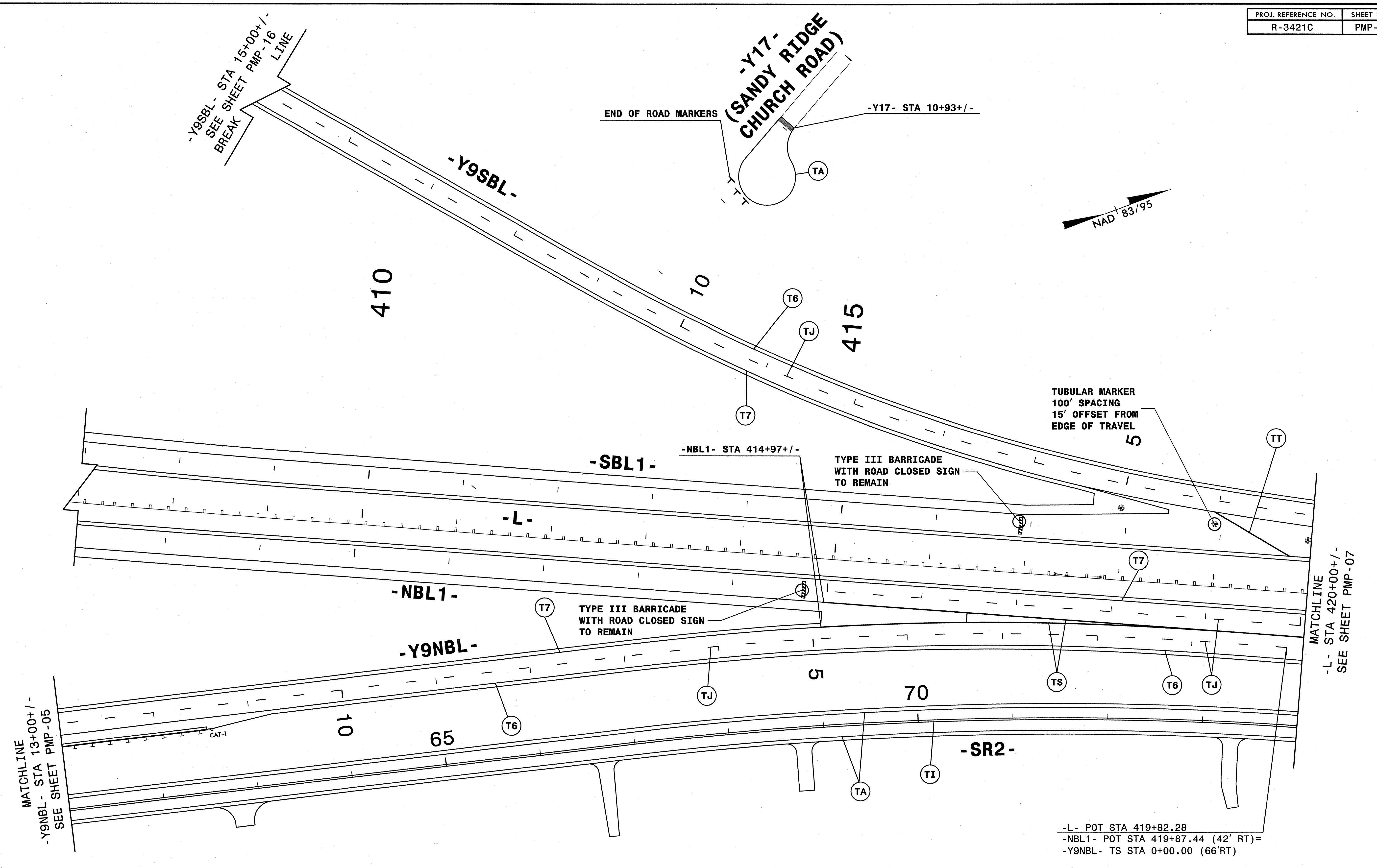

-L- POT STA 419+82.28
 -NBL1- POT STA 419+87.44 (42' RT)=
 -Y9NBL- TS STA 0+00.00 (66'RT)

CONTRACTOR IS TO VERIFY PASSING ZONES ON TWO-LANE TWO-WAY ROADS PRIOR TO PLACING PAVEMENT MARKINGS ON FINAL SURFACE COURSE.

REVISIONS

QA/QC STAGE:	
REVIEW:	RSE 7/26/12
CONCUR:	
REVISE:	RAC 8/1/12
VERIFY:	

APPROVED: *Handwritten Signature* DATE: 8-2-12

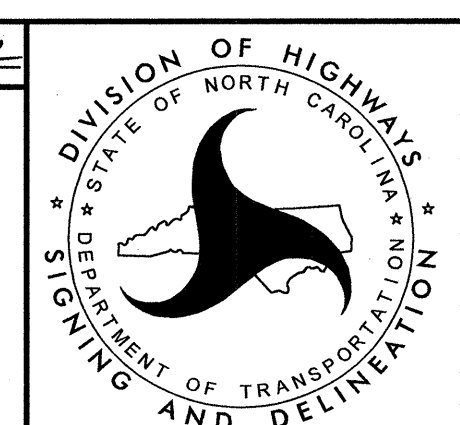
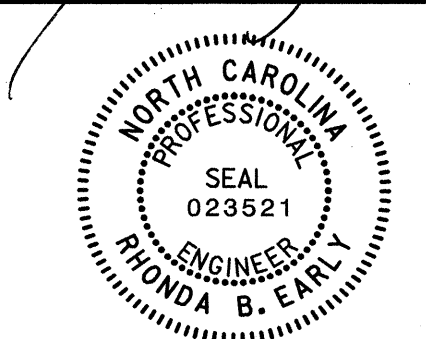

SIGNING AND DELINEATION
FINAL PAVEMENT MARKING PLANS

HNTB HNTB NORTH CAROLINA, P.C.
 249 E. Six Forks Road, Suite 200
 Raleigh, North Carolina 27609
 NC License No: C-1554

8/17/99

REVISIONS

-NBL1- POT STA 425+05.17 (42' RT) LB=
 -SBL1- POT STA 425+96.03 (42' LT) LB=
 -L- POT STA 425+00.00 LA

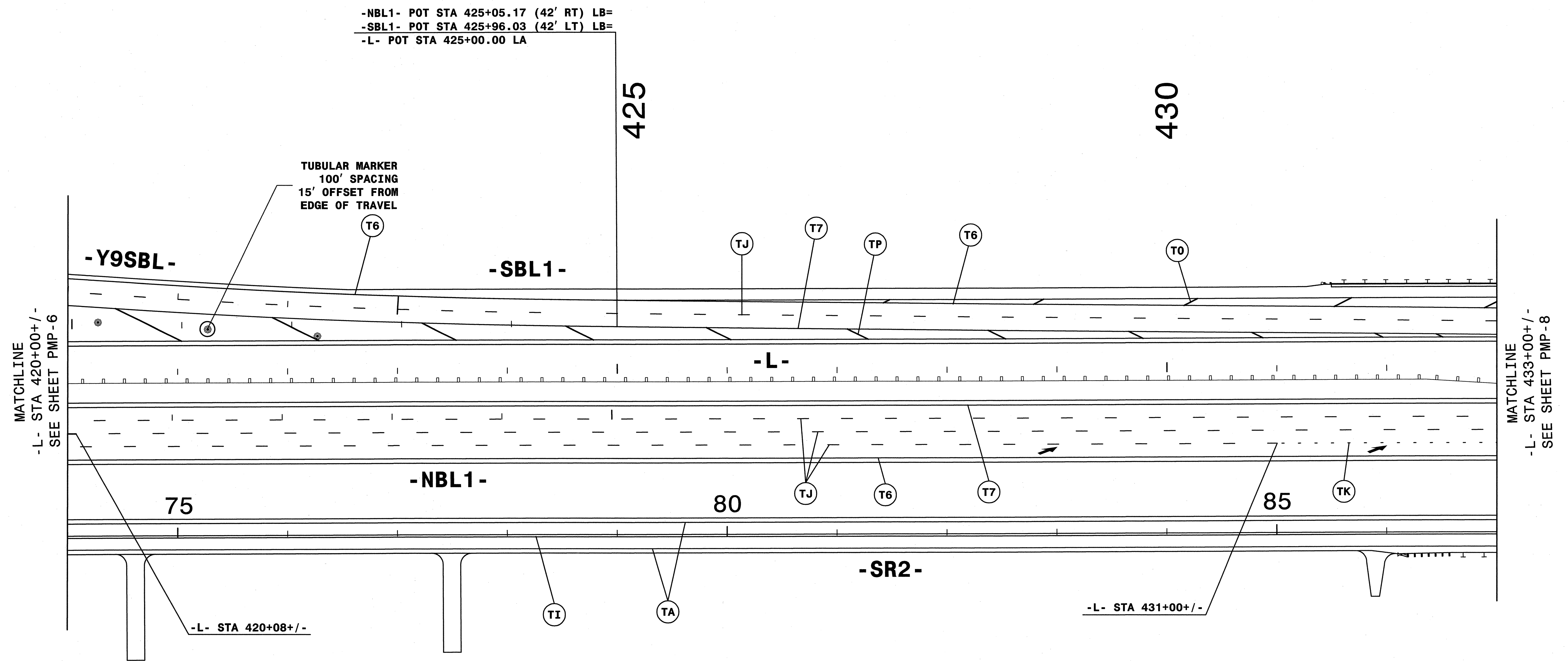

MATCHLINE
 -L- STA 420+00+/-
 SEE SHEET PMP-6

MATCHLINE
 -L- STA 433+00+/-
 SEE SHEET PMP-8

TUBULAR MARKER
 100' SPACING
 15' OFFSET FROM
 EDGE OF TRAVEL

CONTRACTOR IS TO VERIFY PASSING ZONES
 ON TWO-LANE TWO-WAY ROADS PRIOR TO
 PLACING PAVEMENT MARKINGS ON FINAL
 SURFACE COURSE.

QA/QC STAGE: _____
 REVIEW: RSE 7/26/12
 CONCUR: _____
 REVISE: RAC 8/11/12
 VERIFY: _____

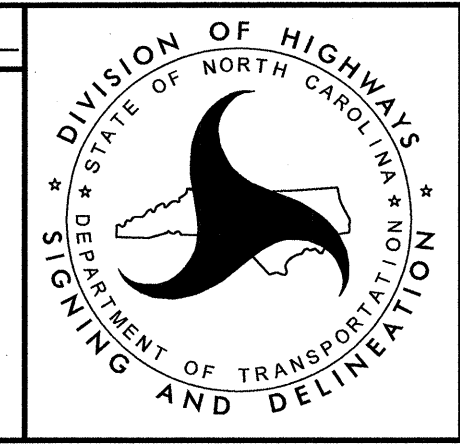
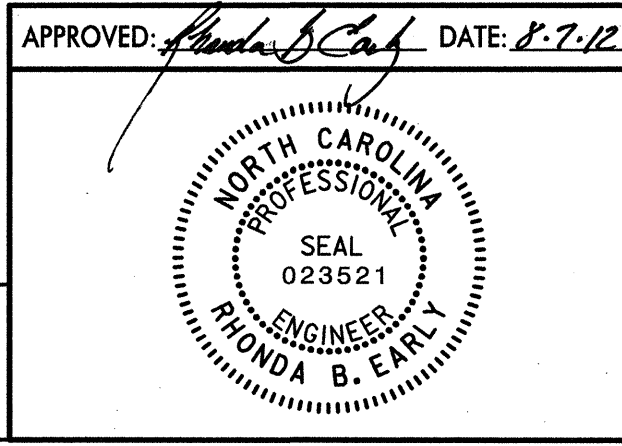
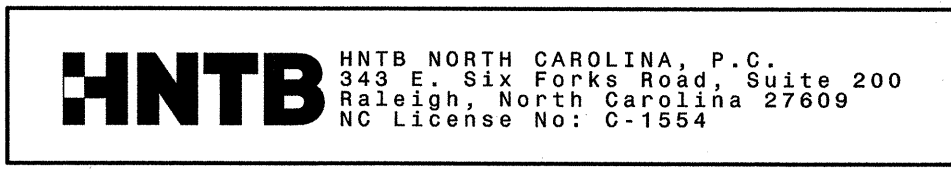

SIGNING AND DELINEATION
FINAL PAVEMENT MARKING PLANS

8/17/99

REVISIONS

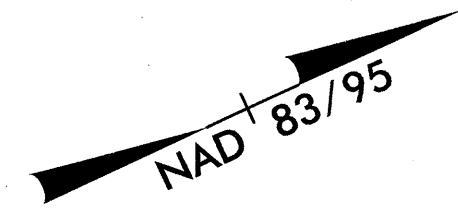
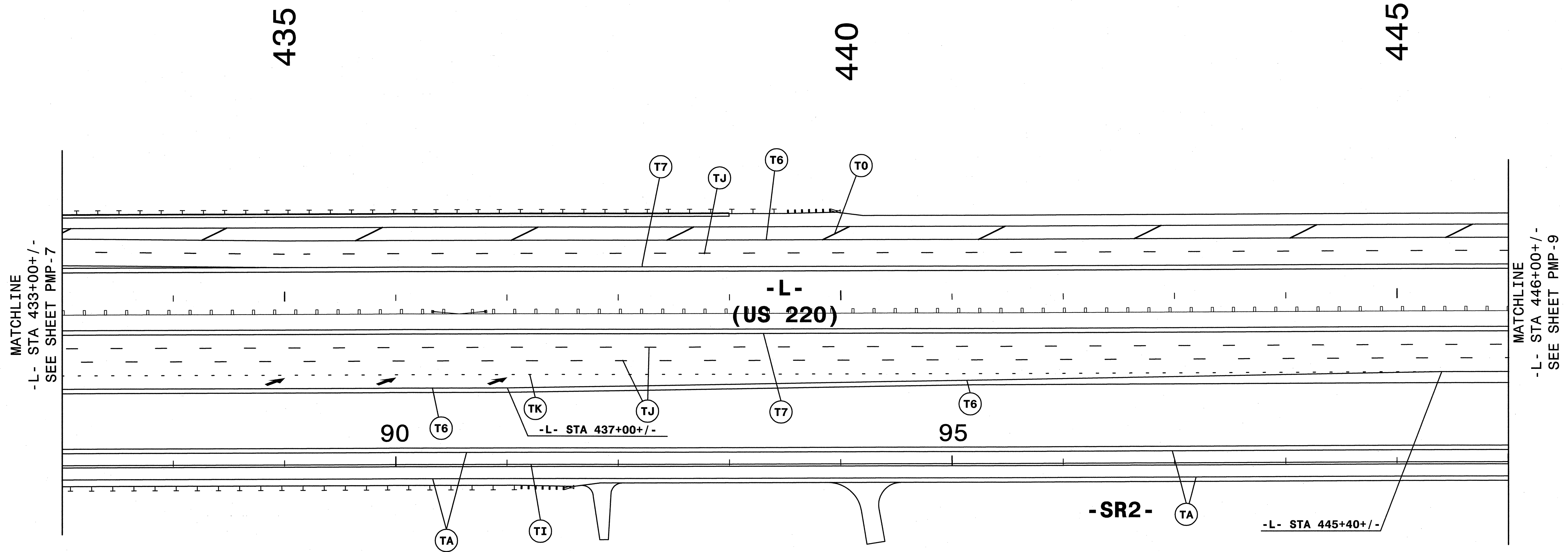

 SYSTEMS
 CONSULTANTS
 INC.
 10000

QA/QC STAGE:	
REVIEW:	RSE 7/26/12
CONCUR:	
REVISE:	RAC 8/1/12
VERIFY:	

CONTRACTOR IS TO VERIFY PASSING ZONES ON TWO-LANE TWO-WAY ROADS PRIOR TO PLACING PAVEMENT MARKINGS ON FINAL SURFACE COURSE.

HNTB HNTB NORTH CAROLINA, P.C.
 949 E. Six Forks Road, Suite 200
 Raleigh, North Carolina 27609
 NC License No: C-1554

APPROVED: *[Signature]* DATE: 8.7.12

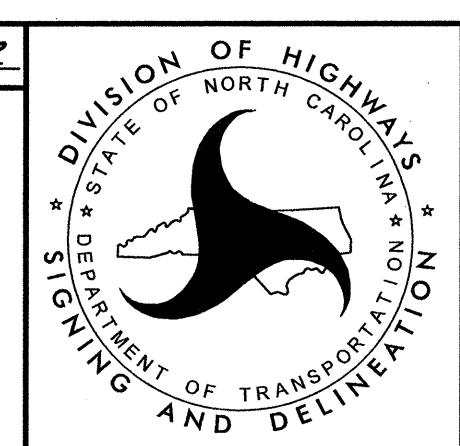

SIGNING AND DELINEATION
FINAL PAVEMENT MARKING PLANS

8/17/99

REVISIONS

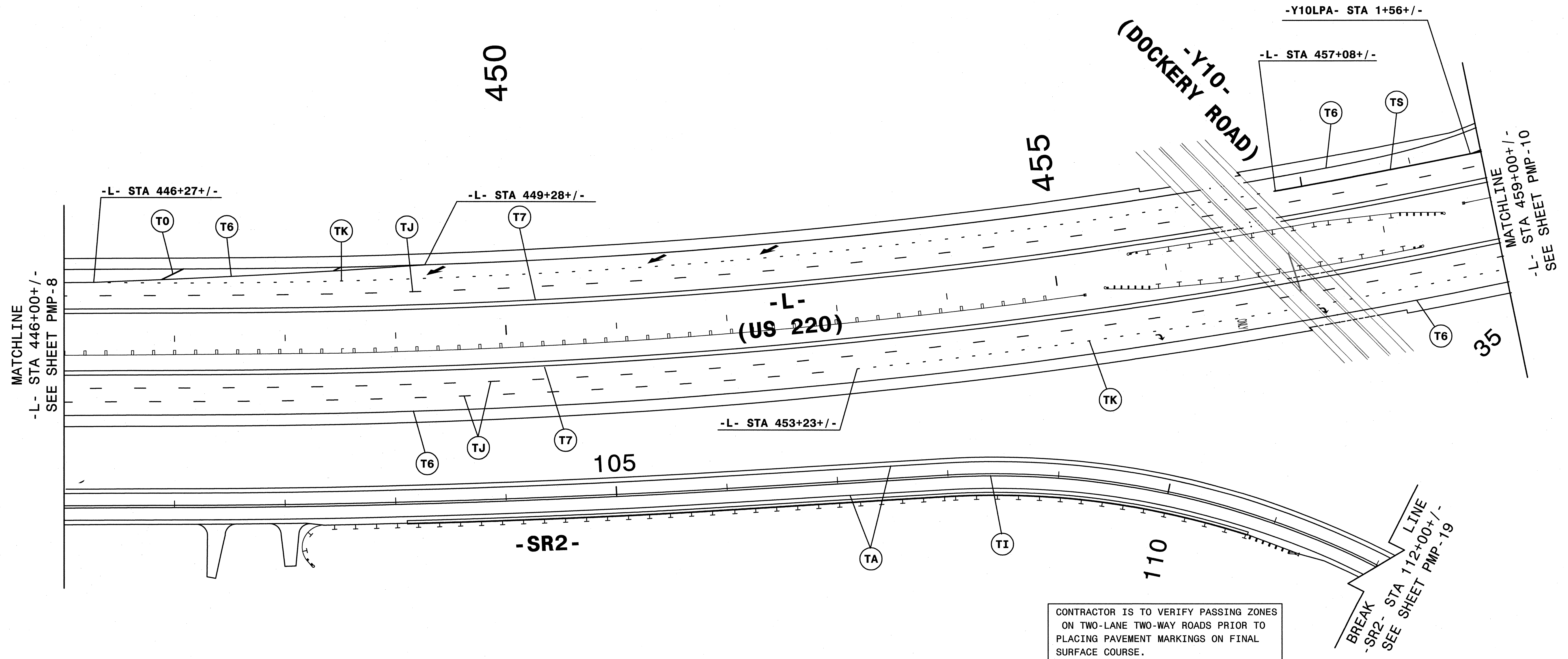

MATCHLINE
-L- STA 446+00+/-
SEE SHEET PMP-8

MATCHLINE
-L- STA 459+00+/-
SEE SHEET PMP-10

BREAK
-SR2- STA 112+00+/-
SEE SHEET PMP-19

CONTRACTOR IS TO VERIFY PASSING ZONES ON TWO-LANE TWO-WAY ROADS PRIOR TO PLACING PAVEMENT MARKINGS ON FINAL SURFACE COURSE.

QA/QC STAGE:	
REVIEW:	RSE 7/26/12
CONCUR:	
REVISE:	RAC 8/17/12
VERIFY:	

HNTB HNTB NORTH CAROLINA, P.C.
3449 E. Six Forks Road, Suite 200
Raleigh, North Carolina 27609
NC License No: C-1554

APPROVED: *[Signature]* DATE: 8.7.12

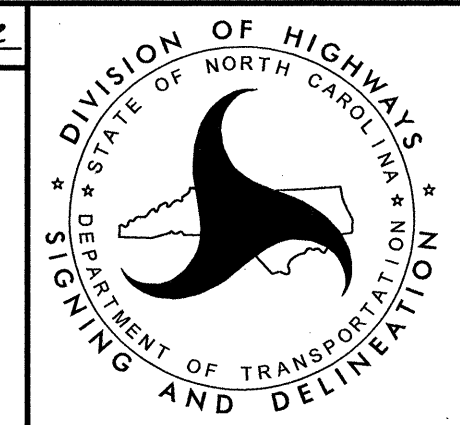
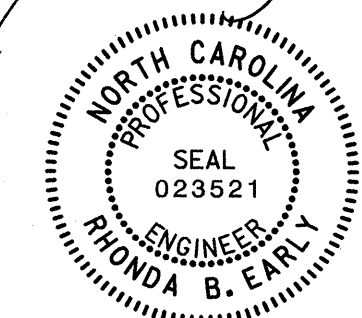

SIGNING AND DELINEATION
FINAL PAVEMENT MARKING PLANS

8/17/99

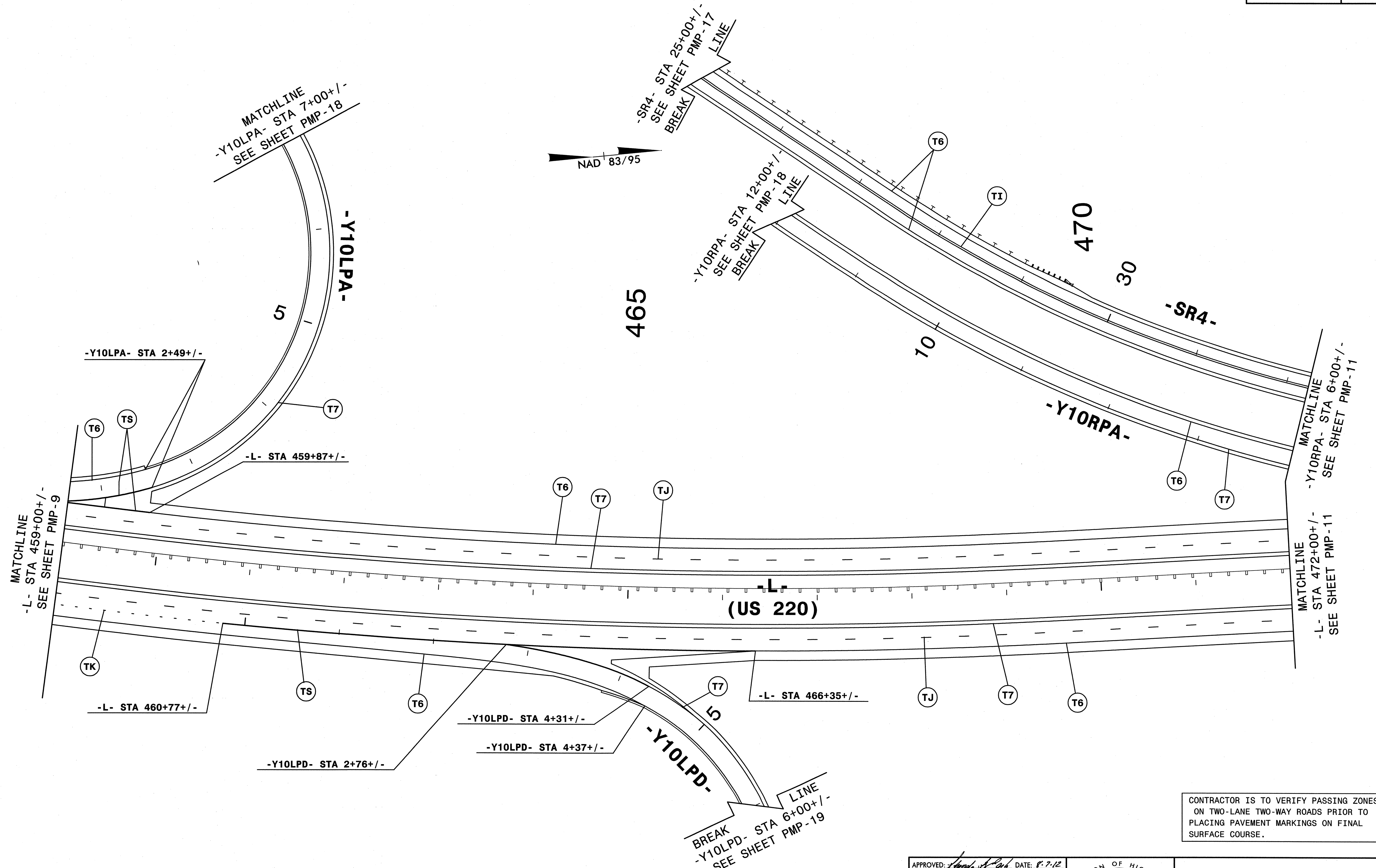
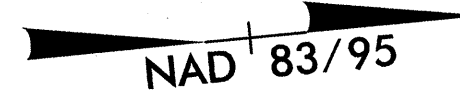

REVISIONS

QA/QC STAGE:	
REVIEW:	RSE 7/26/12
CONCUR:	
REVISE:	RAC 8/1/12
VERIFY:	

CONTRACTOR IS TO VERIFY PASSING ZONES ON TWO-LANE TWO-WAY ROADS PRIOR TO PLACING PAVEMENT MARKINGS ON FINAL SURFACE COURSE.

APPROVED: *[Signature]* DATE: 8.7.12



HNTB HNTB NORTH CAROLINA, P.C.
243 E. Six Forks Road, Suite 200
Raleigh, North Carolina 27609
NC License No: C-1554

SIGNING AND DELINEATION
FINAL PAVEMENT MARKING PLANS

8/17/99

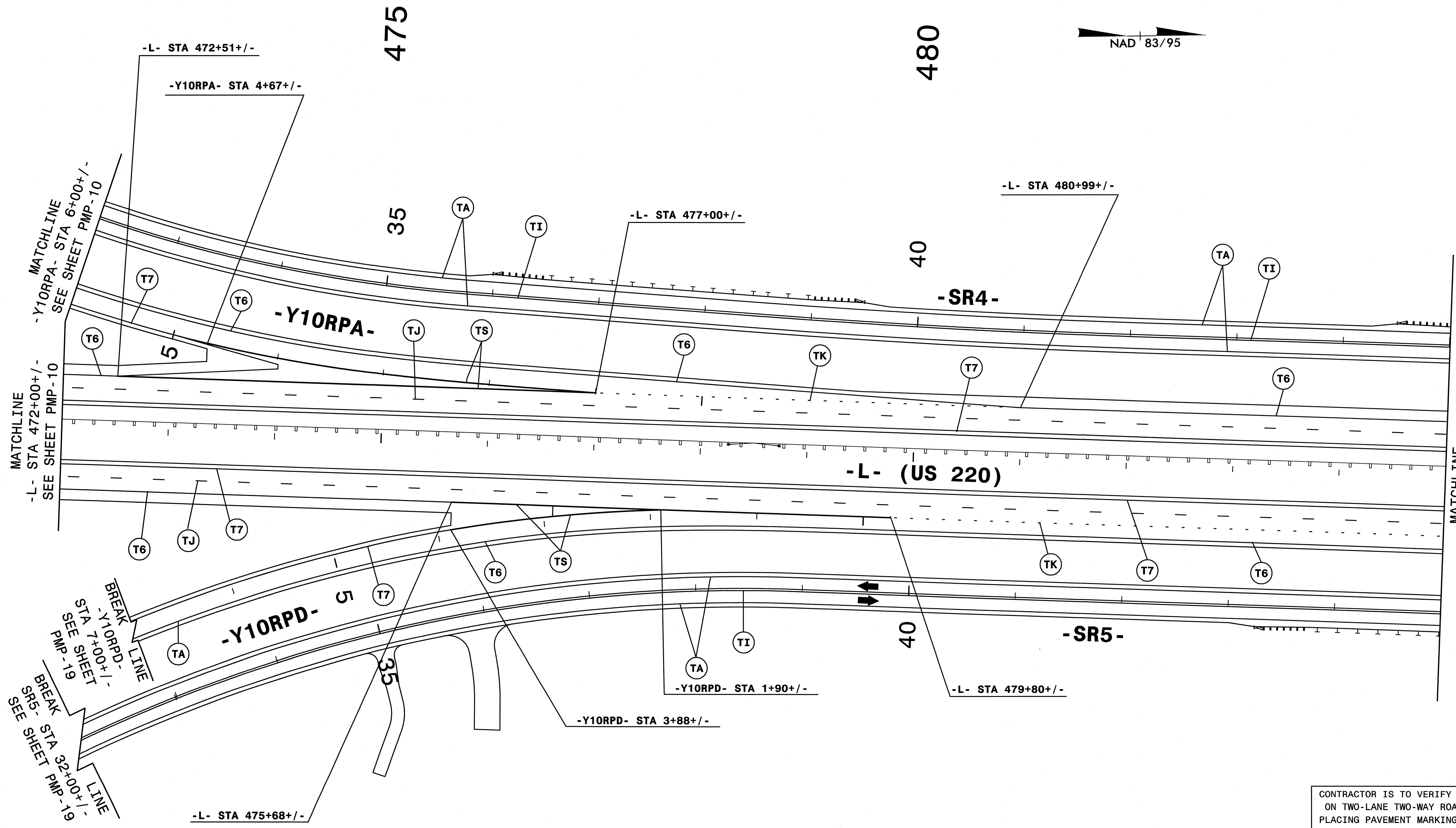

REVISIONS

QA/QC STAGE:	
REVIEW:	RSE 7/26/12
CONCUR:	
REVISE:	RAC 8/17/12
VERIFY:	

CONTRACTOR IS TO VERIFY PASSING ZONES ON TWO-LANE TWO-WAY ROADS PRIOR TO PLACING PAVEMENT MARKINGS ON FINAL SURFACE COURSE.

APPROVED: *[Signature]* DATE: 8.7.12

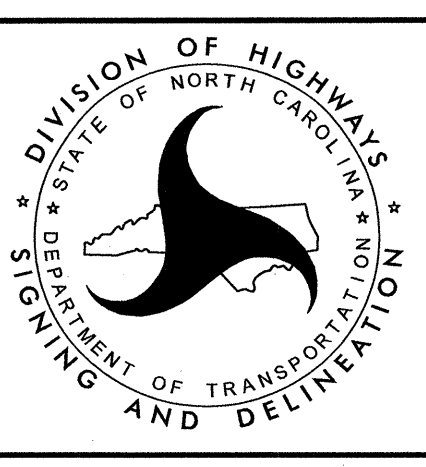

SIGNING AND DELINEATION
FINAL PAVEMENT MARKING PLANS

HNTB HNTB NORTH CAROLINA, P.C.
243 E. Six Forks Road, Suite 200
Raleigh, North Carolina 27609
NC License No: C-1554

8/17/99

485

490

495

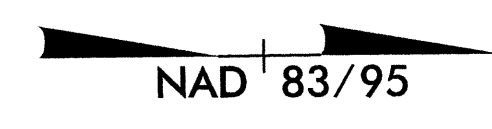

50

55

MATCHLINE
-L- STA 485+00+/-
SEE SHEET PMP-11

BREAK
LINE
-L- STA 498+00+/-
SEE SHEET PMP-13

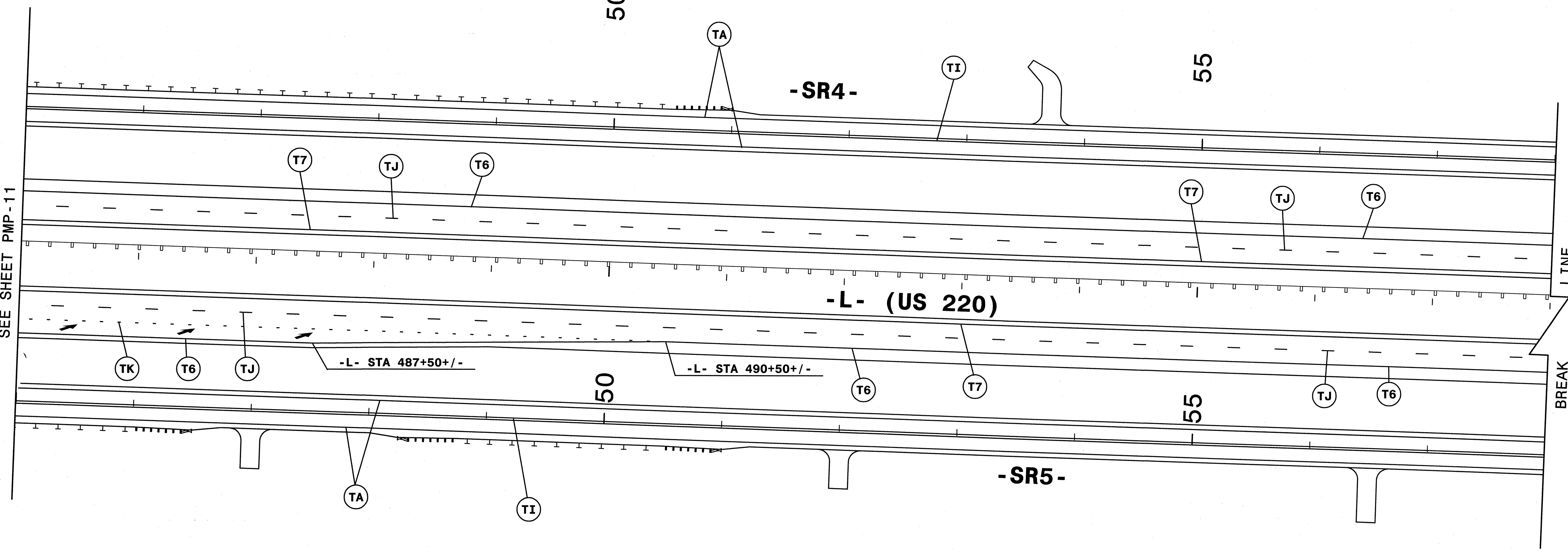

REVISIONS

QA/QC STAGE:	
REVIEW:	RSE 7/26/12
CONCUR:	
REVISE:	RAC 8/17/12
VERIFY:	

CONTRACTOR IS TO VERIFY PASSING ZONES ON TWO-LANE TWO-WAY ROADS PRIOR TO PLACING PAVEMENT MARKINGS ON FINAL SURFACE COURSE.

HNTB HNTB NORTH CAROLINA, P.C.
343 E. SIX FORKS ROAD, SUITE 200
RALEIGH, NORTH CAROLINA 27609
NC LICENSE NO: C-1554

APPROVED: *[Signature]* DATE: 8-7-12

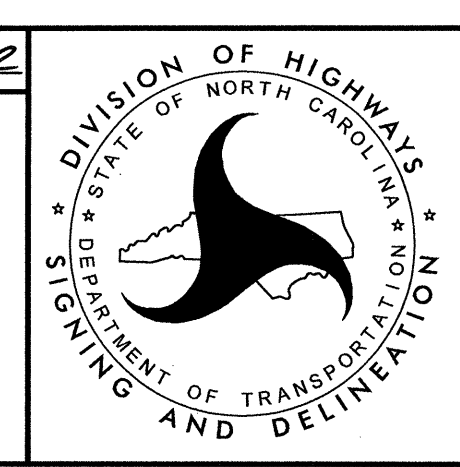

SIGNING AND DELINEATION
FINAL PAVEMENT MARKING PLANS

8/17/99

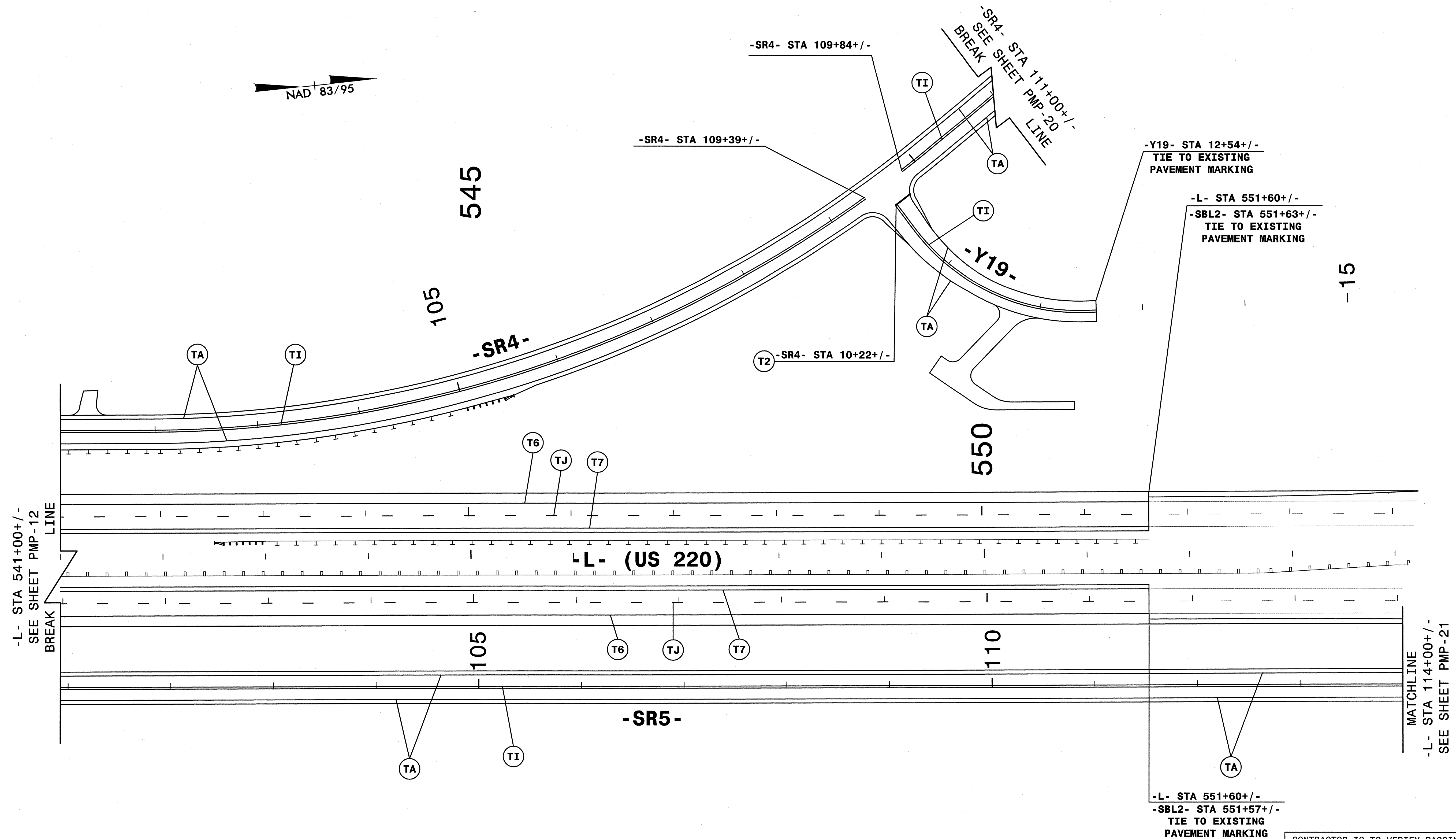
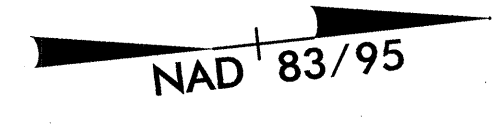

REVISIONS

GAQC STAGE:	REVIEW: RSE	7/26/12
	CONCUR:	
	REVISE: RAC	8/1/12
	VERIFY:	

SYSTEMS
USERS
DATE

-Y19- STA 12+54+/-
TIE TO EXISTING
PAVEMENT MARKING

-L- STA 551+60+/-
-SBL2- STA 551+63+/-
TIE TO EXISTING
PAVEMENT MARKING

-L- STA 551+60+/-
-SBL2- STA 551+57+/-
TIE TO EXISTING
PAVEMENT MARKING

CONTRACTOR IS TO VERIFY PASSING ZONES ON TWO-LANE TWO-WAY ROADS PRIOR TO PLACING PAVEMENT MARKINGS ON FINAL SURFACE COURSE.

APPROVED: *[Signature]* DATE: 8/2/12

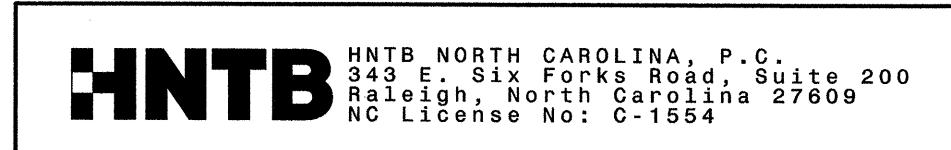
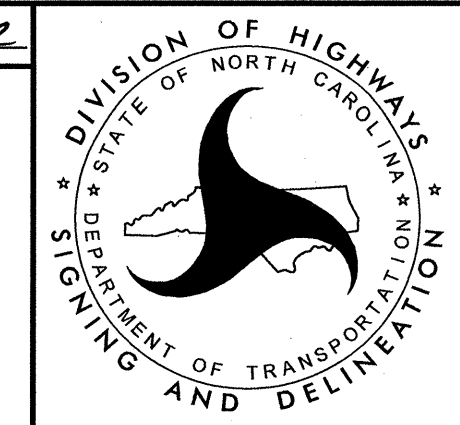
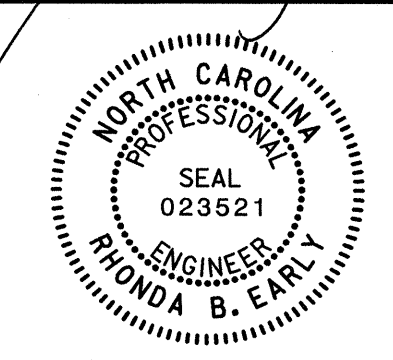

SIGNING AND DELINEATION
FINAL PAVEMENT MARKING PLANS

8/17/99

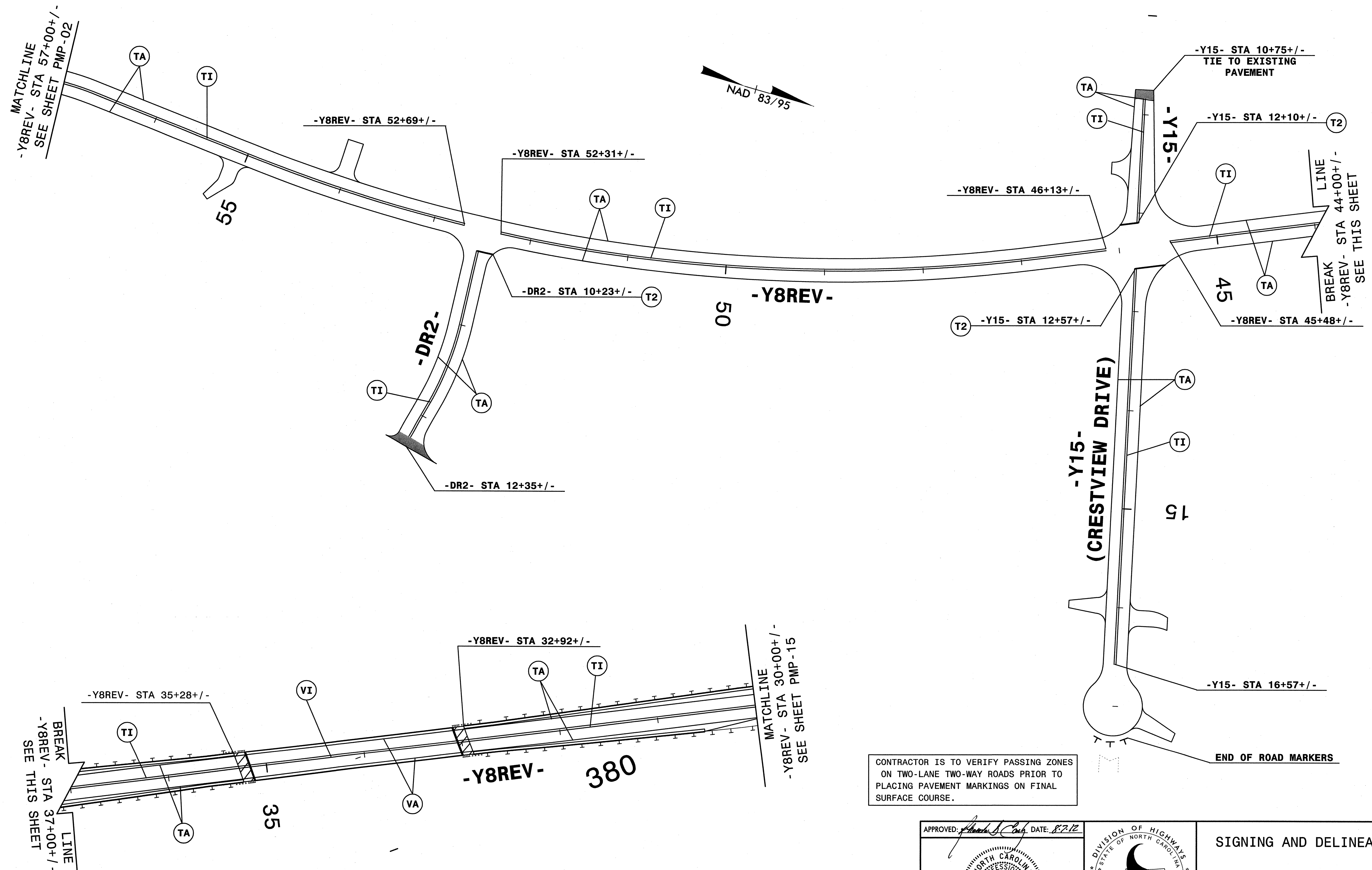

REVISIONS

QA/QC STAGE:	REVIEW:	RSE	7/26/12
	CONCUR:		
	REVISE:	RAC	8/1/12
	VERIFY:		

CONTRACTOR IS TO VERIFY PASSING ZONES ON TWO-LANE TWO-WAY ROADS PRIOR TO PLACING PAVEMENT MARKINGS ON FINAL SURFACE COURSE.

HNTB HNTB NORTH CAROLINA, P.C.
343 E. Six Forks Road, Suite 200
Raleigh, North Carolina 27609
NC License No: C-1554

APPROVED: *[Signature]* DATE: 8/7/12

NORTH CAROLINA PROFESSIONAL ENGINEER
SEAL 023521
RYONDA B. EARLY

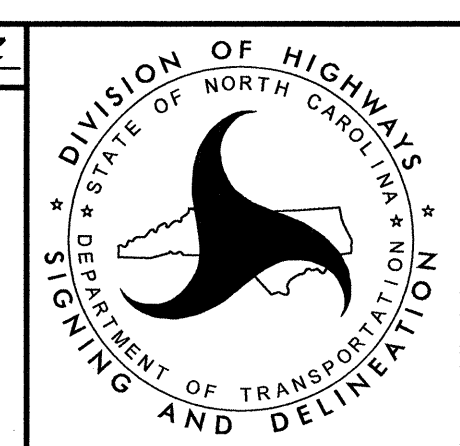

SIGNING AND DELINEATION
FINAL PAVEMENT MARKING PLANS

8/17/99

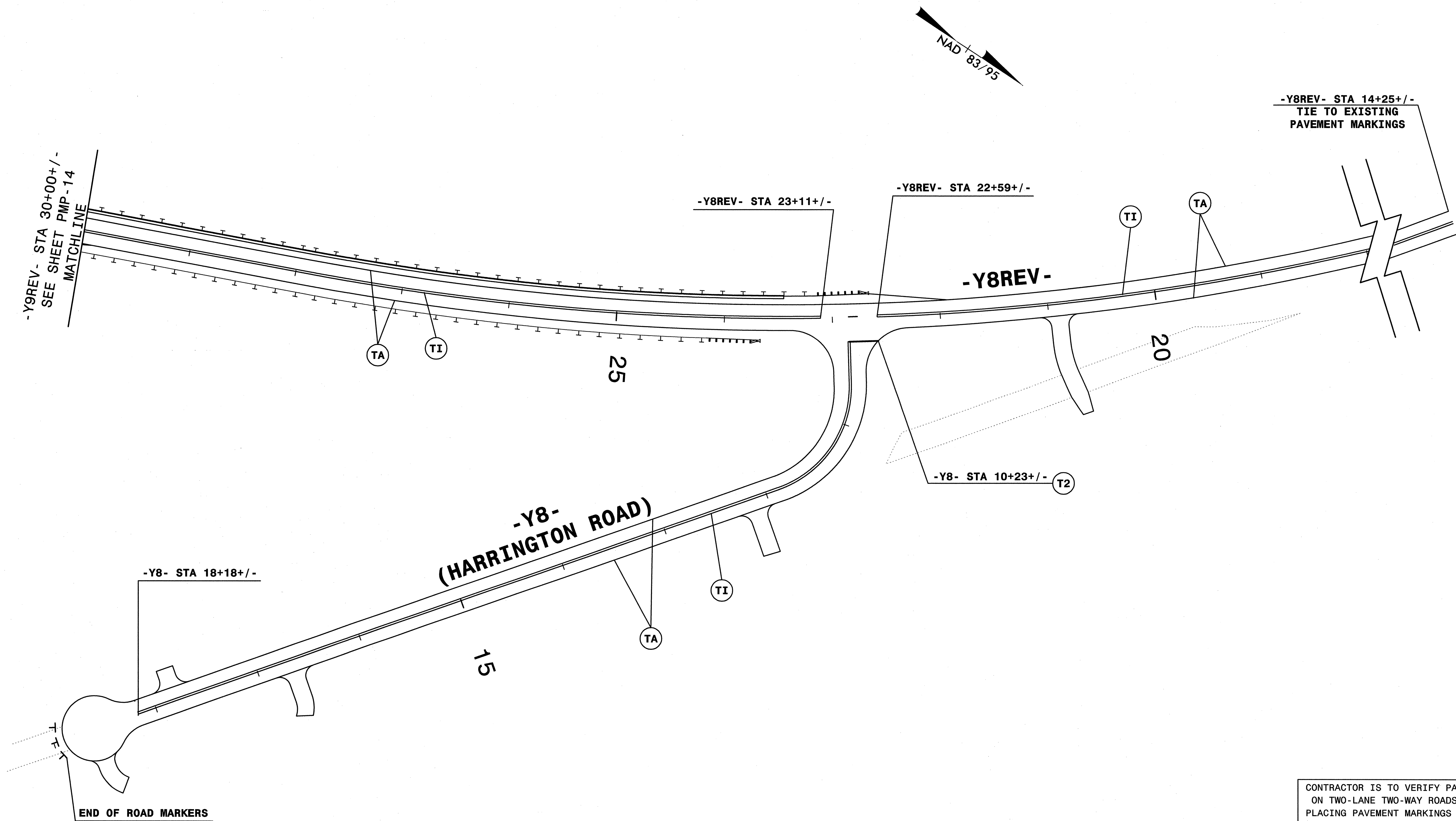

REVISIONS

QA/QC STAGE:	
REVIEW:	RSE 7/26/12
CONCUR:	
REVISE:	RAC 8/1/12
VERIFY:	

CONTRACTOR IS TO VERIFY PASSING ZONES ON TWO-LANE TWO-WAY ROADS PRIOR TO PLACING PAVEMENT MARKINGS ON FINAL SURFACE COURSE.

HNTB HNTB NORTH CAROLINA, P.C.
 343 E. Six Forks Road, Suite 200
 Raleigh, North Carolina 27609
 NC License No: C-1554

APPROVED: *[Signature]* DATE: 8.2.12

PROFESSIONAL ENGINEER
 SEAL 023521
 RYONDA B. EARLY

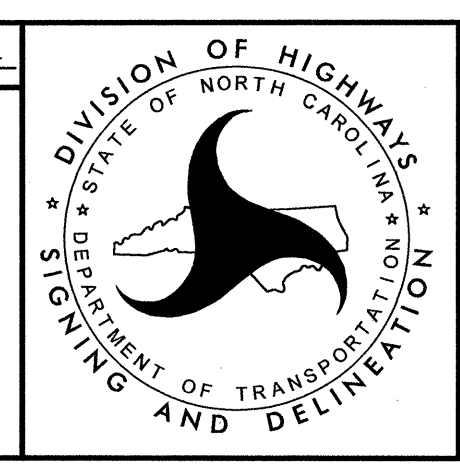

SIGNING AND DELINEATION

FINAL PAVEMENT MARKING PLANS

8/17/99

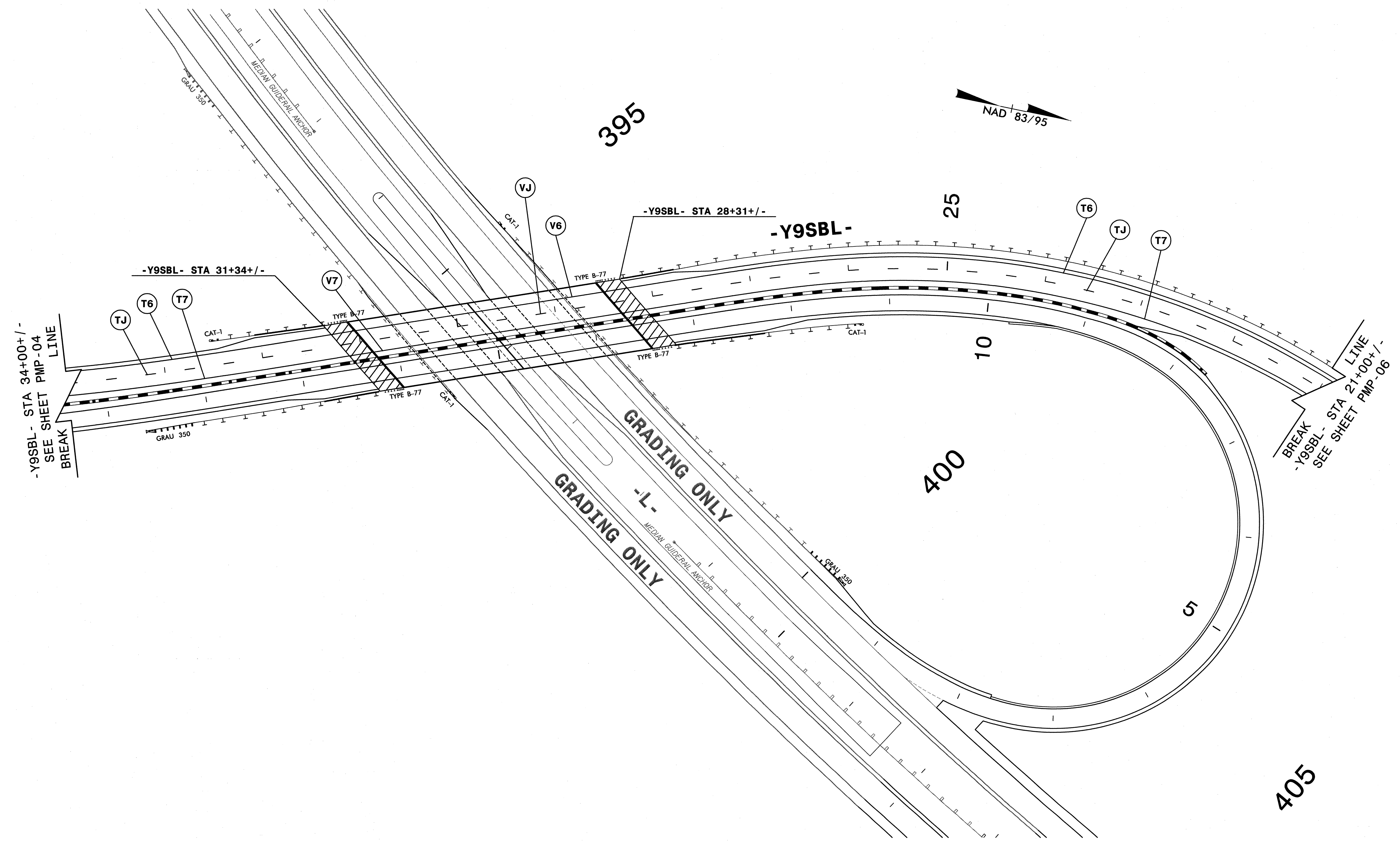

REVISIONS

GAQC STAGE:	
REVIEW:	RSE 7/26/12
CONCUR:	
REVISE:	RAC 8/1/12
VERIFY:	

SYTIME
UNSUB
UNSUB

HNTB HNTB NORTH CAROLINA, P.C.
349 E. Six Forks Road, Suite 200
Raleigh, North Carolina 27609
NC License No: C-1554

APPROVED: *[Signature]* DATE: 8.7.12

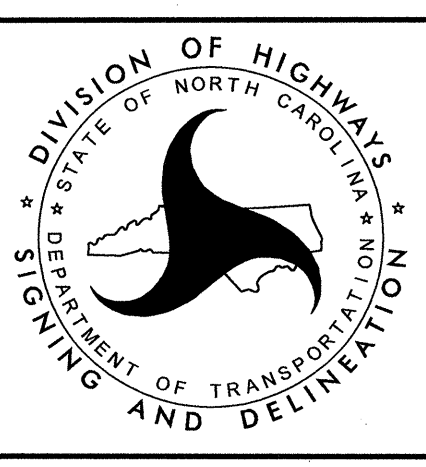

SIGNING AND DELINEATION
FINAL PAVEMENT MARKING PLANS

8/17/99

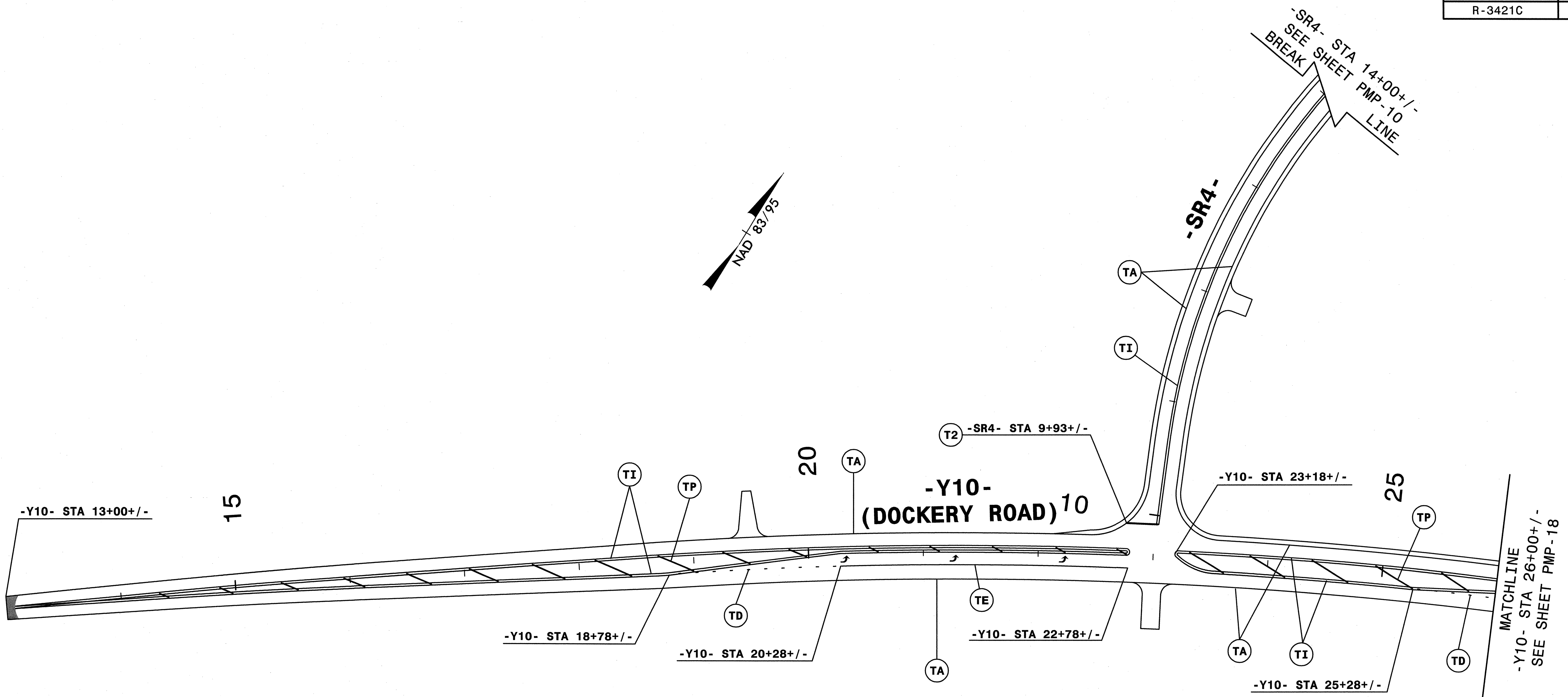

REVISIONS

SYTIME
 CONCUR:
 RAC
 VERIFY:

QA/QC STAGE:
 REVIEW: RSE 7/26/12
 CONCUR: RAC 8/1/12
 REVISIONS:

CONTRACTOR IS TO VERIFY PASSING ZONES ON TWO-LANE TWO-WAY ROADS PRIOR TO PLACING PAVEMENT MARKINGS ON FINAL SURFACE COURSE.

HNTB HNTB NORTH CAROLINA, P.C.
 343 E. Six Forks Road, Suite 200
 Raleigh, North Carolina 27609
 NC License No: C-1554

APPROVED: *[Signature]* DATE: 8.2.12
 NORTH CAROLINA PROFESSIONAL ENGINEER
 SEAL 023521
 RYONDA B. EARLY

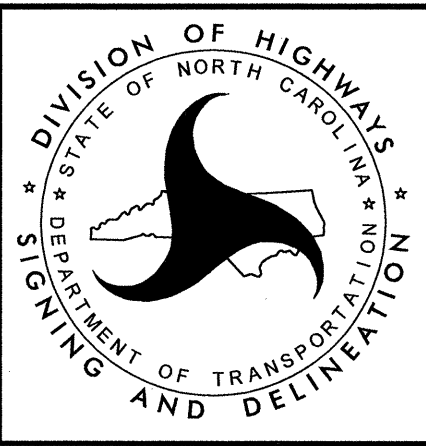

SIGNING AND DELINEATION
FINAL PAVEMENT MARKING PLANS

8/17/99

REVISIONS

QA/QC STAGE:
 REVIEW: RSE 7/26/12
 CONCUR: RAC 8/1/12
 REVISE:
 VERIFY:

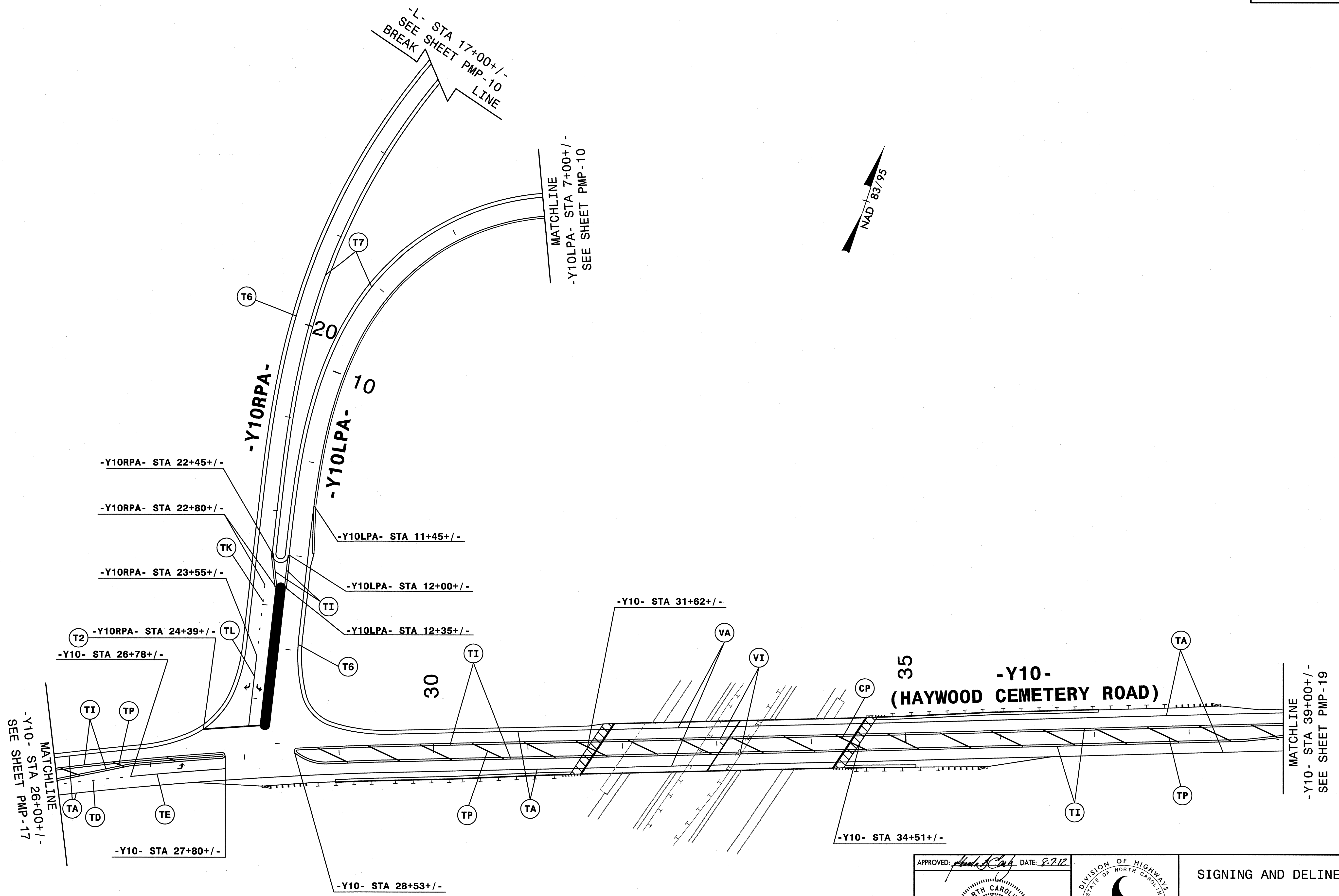

APPROVED: *[Signature]* DATE: 8.2.12

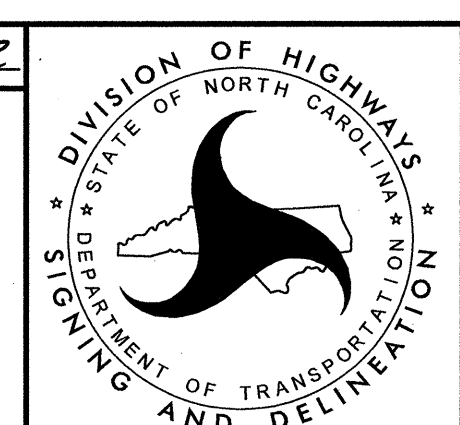

SIGNING AND DELINEATION
FINAL PAVEMENT MARKING PLANS

HNTB HNTB NORTH CAROLINA, P.C.
 249 E. Six Forks Road, Suite 200
 Raleigh, North Carolina 27609
 NC License No: C-1554

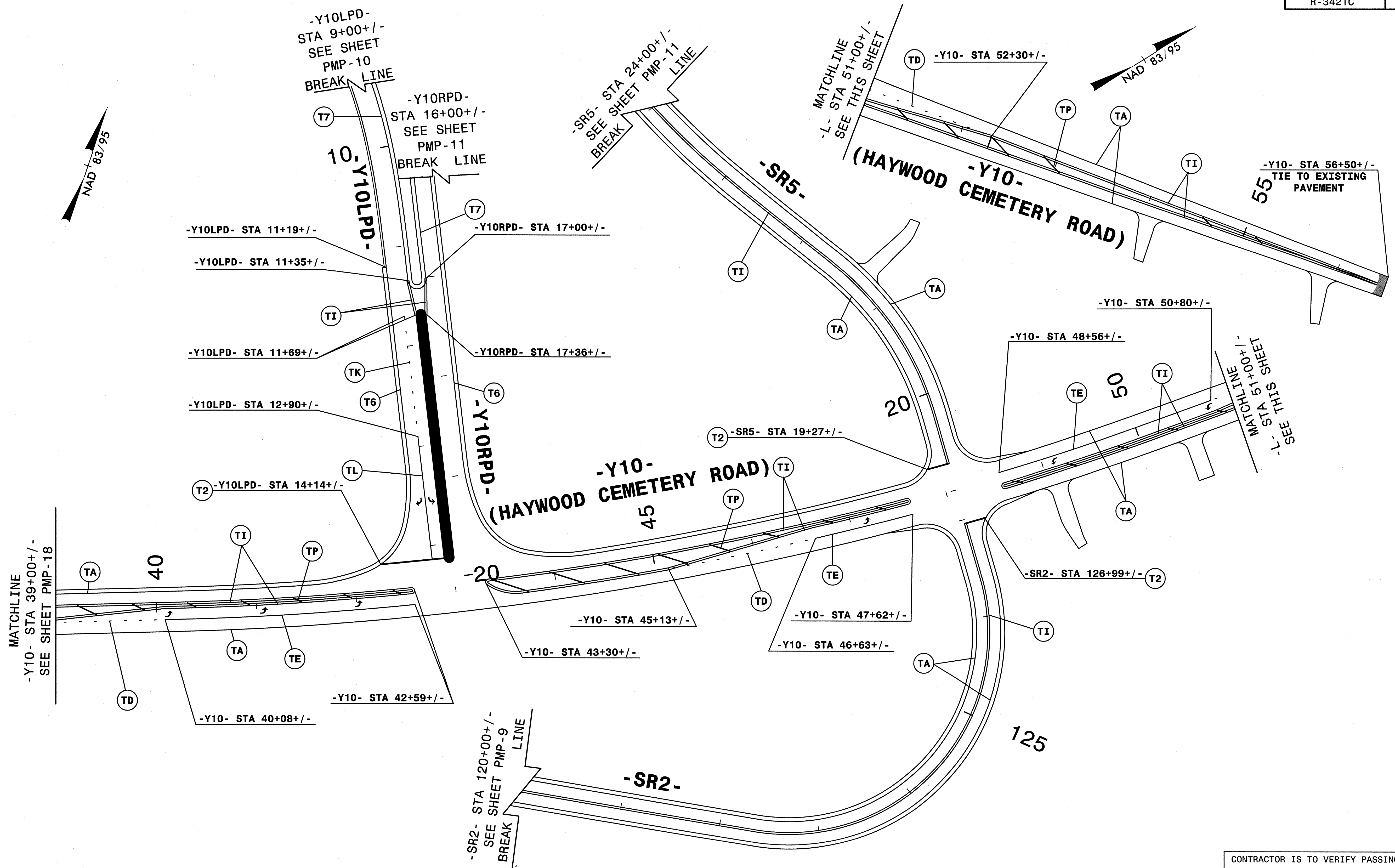

REVISIONS

QA/QC STAGE:	
REVIEW:	RSE 7/26/12
CONCUR:	
REVISE:	RAC 8/17/12
VERIFY:	

CONTRACTOR IS TO VERIFY PASSING ZONES ON TWO-LANE TWO-WAY ROADS PRIOR TO PLACING PAVEMENT MARKINGS ON FINAL SURFACE COURSE.

HNTB HNTB NORTH CAROLINA, P.C.
343 E. Six Forks Road, Suite 200
Raleigh, North Carolina 27609
NC License No: C-1554

APPROVED: *[Signature]* DATE: 8.2.12



SIGNING AND DELINEATION
FINAL PAVEMENT MARKING PLANS

8/17/99

REVISIONS

QA/QC STAGE:	
REVIEW:	RSE 7/26/12
CONCUR:	
REVISE:	RAC 8/1/12
VERIFY:	

MATCHLINE
-L- STA 114+00+/-
SEE SHEET PMP-13

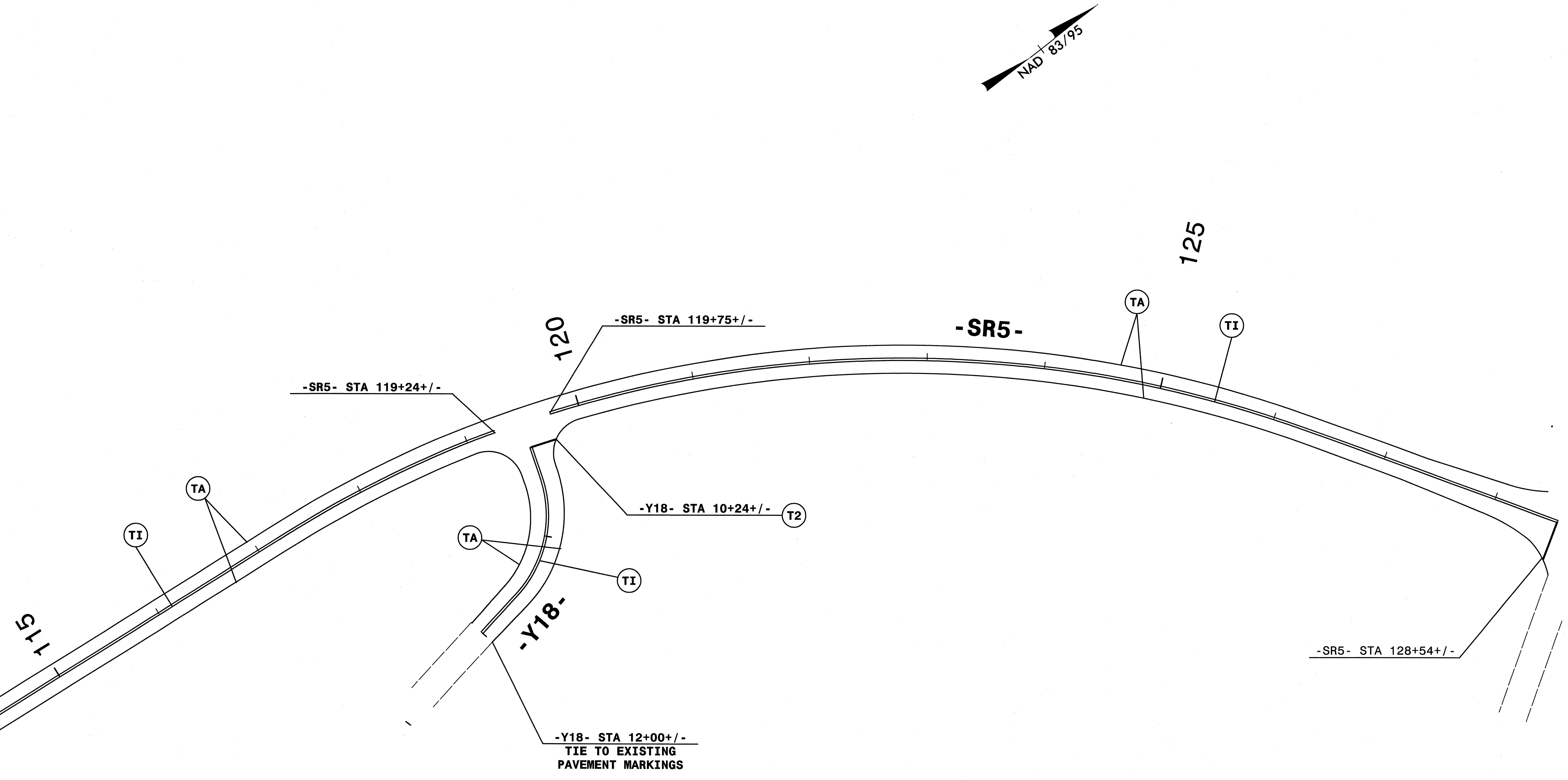

CONTRACTOR IS TO VERIFY PASSING ZONES ON TWO-LANE TWO-WAY ROADS PRIOR TO PLACING PAVEMENT MARKINGS ON FINAL SURFACE COURSE.

APPROVED: *[Signature]* DATE: 8/7/12

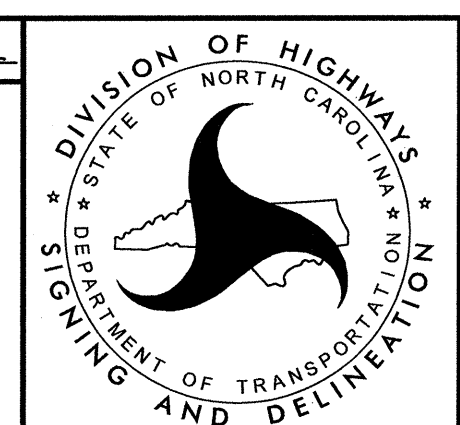

HNTB HNTB NORTH CAROLINA, P.C.
243 E. Six Forks Road, Suite 200
Raleigh, North Carolina 27609
NC License No: C-1554

SIGNING AND DELINEATION
FINAL PAVEMENT MARKING PLANS