

09/08/09

See Sheet 1-A For Index of Sheets  
See Sheet 1-B For Symbology Sheet  
See Sheet 1-C For Control Sheet

STATE OF NORTH CAROLINA  
DIVISION OF HIGHWAYS

**PITT COUNTY**

**LOCATION: BRIDGE NO. III OVER BRIERY SWAMP ON SR 1588**

**TYPE OF WORK: GRADING, DRAINAGE, PAVING AND STRUCTURE**

STATE	STATE PROJECT REFERENCE NO.	SHEET NO.	TOTAL SHEETS
N.C.	B-5111	1	
STATE PROJ. NO.	F.A. PROJ. NO.	DESCRIPTION	
42249.1.1	BRZ-1588(2)	PE	
42249.2.1	BRZ-1588(2)	RW & UTIL	
42249.3.FD1	BRZ-1588(2)	CONST.	

**TIP PROJECT: B-5111**

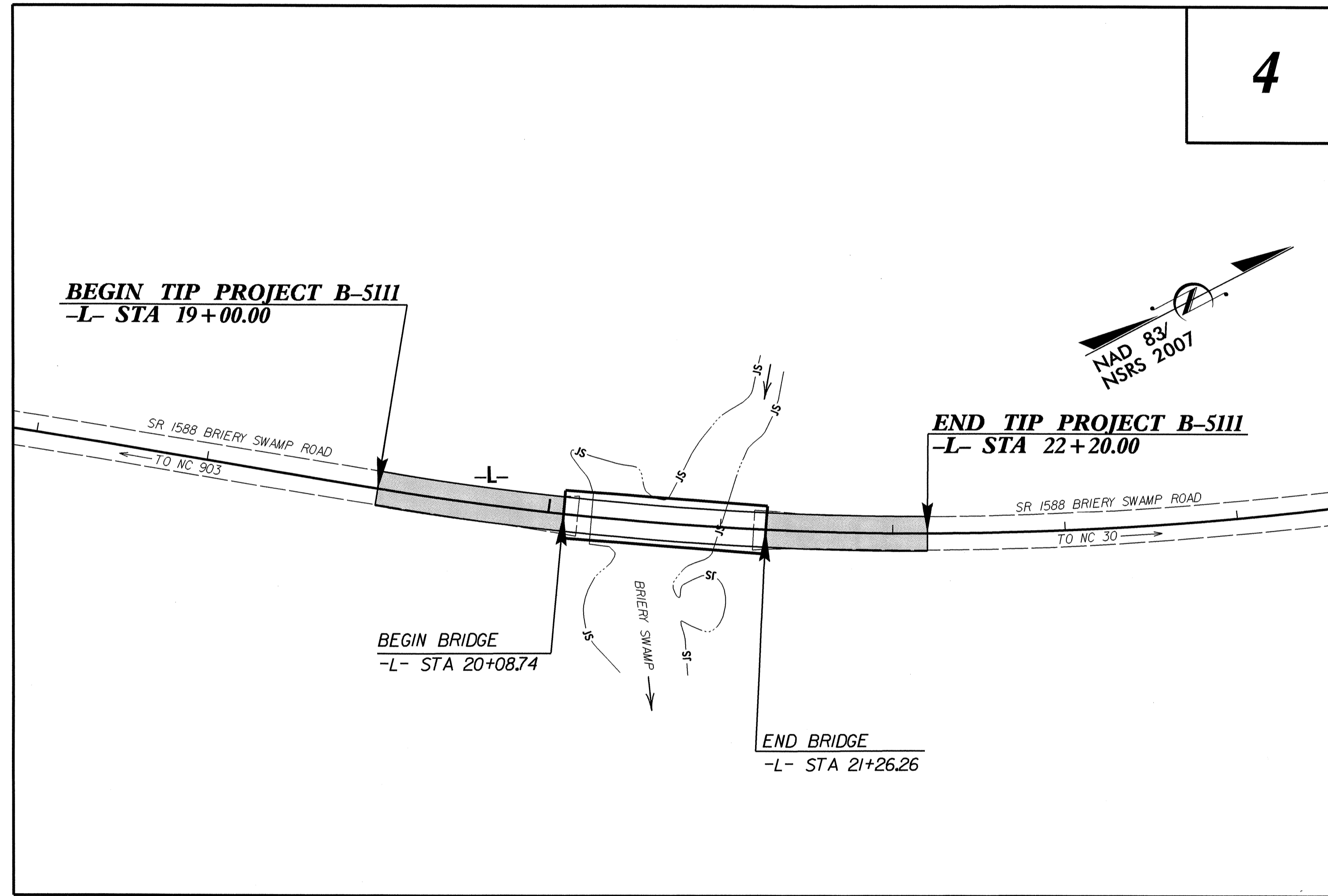
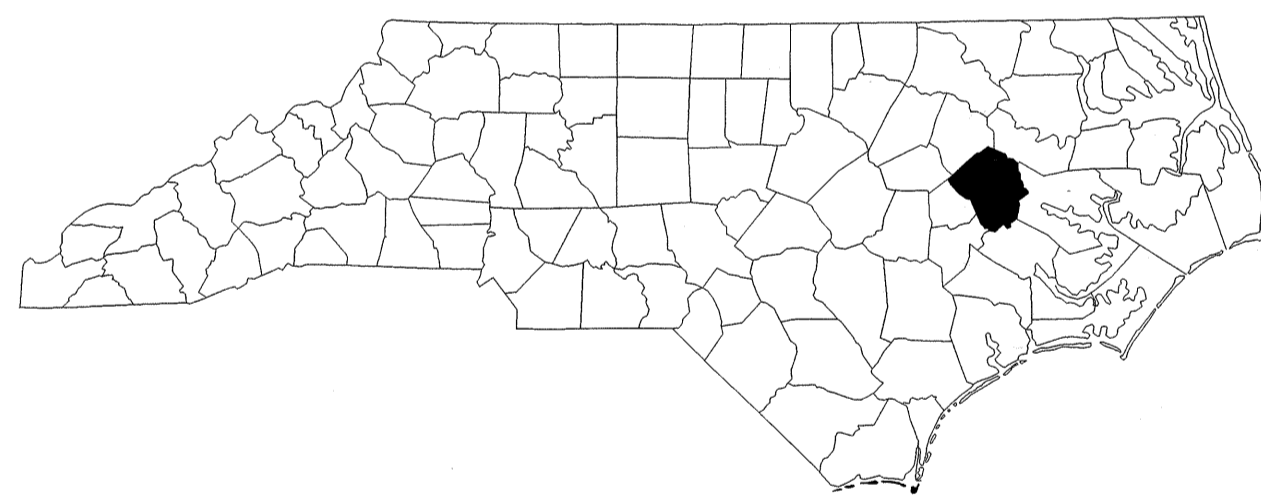
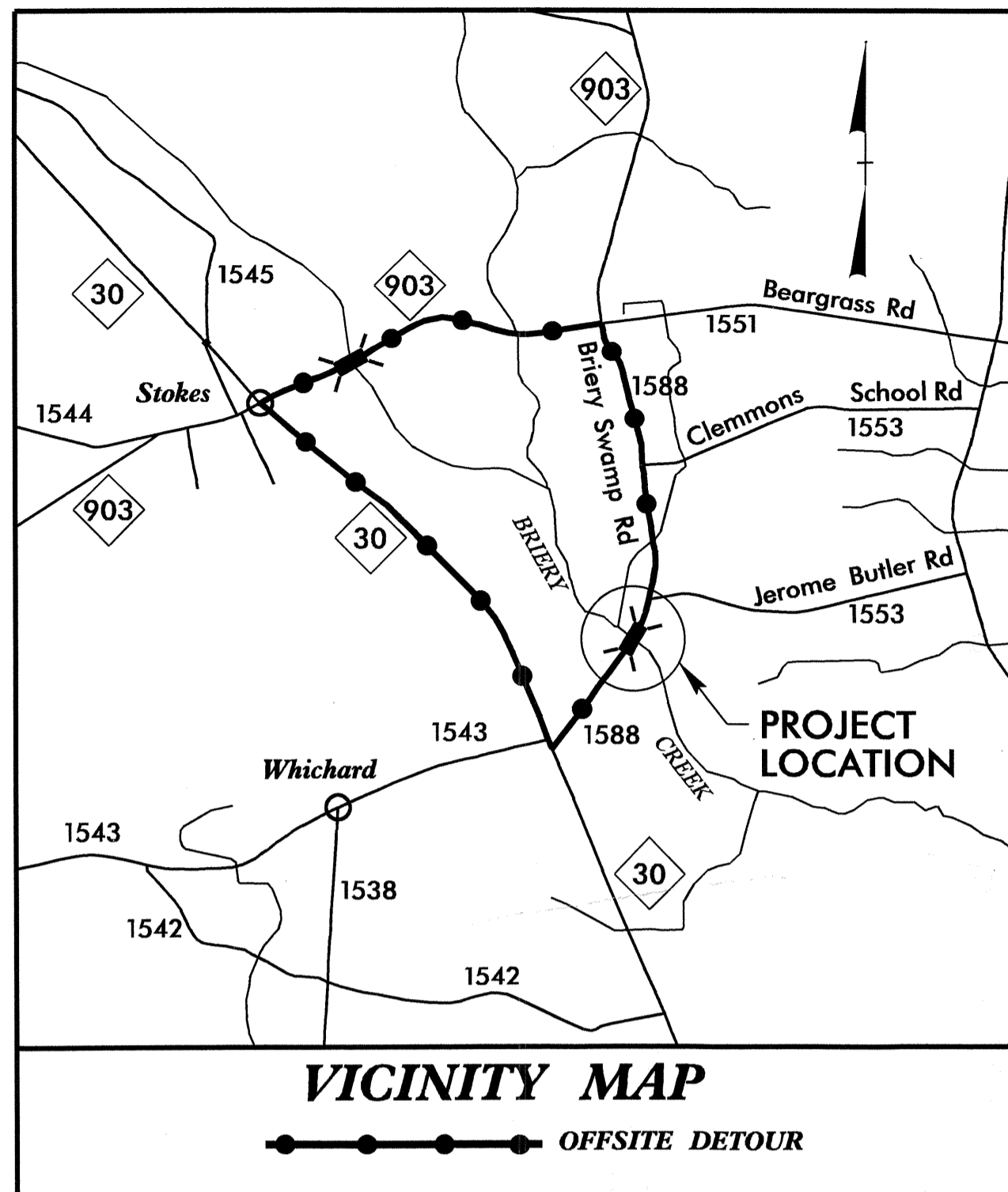

NOTE: DESIGN EXCEPTION REQUIRED FOR MINIMUM HORIZONTAL STOPPING SIGHT DISTANCE OF 376'.

**GRAPHIC SCALES**

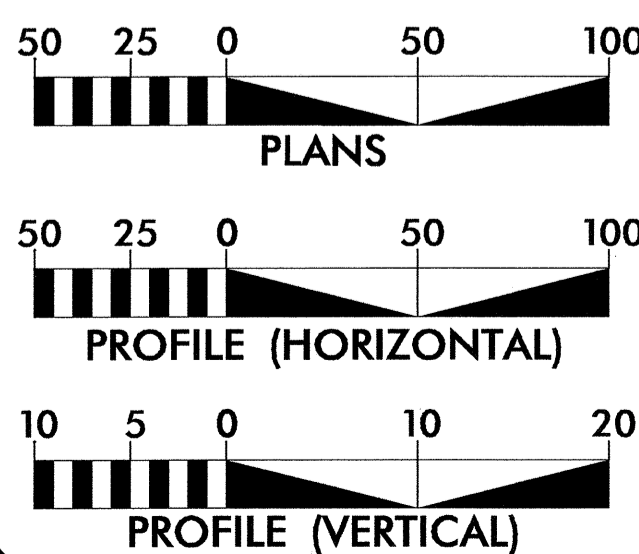

**DESIGN DATA**

ADT 2014 = 589  
 ADT 2034 = 743  
 DHV = 10 %  
 K = 60 %  
 T = 5 % \*  
 V = 60 MPH  
 \* TTST = 2% DUAL 3%  
 FUNC CLASS =  
 RURAL LOCAL  
 SUB-REGIONAL TIER

**PROJECT LENGTH**

LENGTH ROADWAY TIP PROJECT B-5111 = 0.039 MILES  
 LENGTH STRUCTURE TIP PROJECT B-5111 = 0.022 MILES  
 TOTAL LENGTH OF TIP PROJECT B-5111 = 0.061 MILES

Prepared In the Office of:  
**DIVISION OF HIGHWAYS**  
 1000 Birch Ridge Dr., Raleigh NC, 27610

2012 STANDARD SPECIFICATIONS

**RIGHT OF WAY DATE:**  
AUGUST 22, 2012  
**LETTING DATE:**  
JANUARY 21, 2014

**GARY LOVERING, PE**  
PROJECT ENGINEER

**CHRISTOPHER H. LEE**  
PROJECT DESIGN ENGINEER

HYDRAULICS ENGINEER

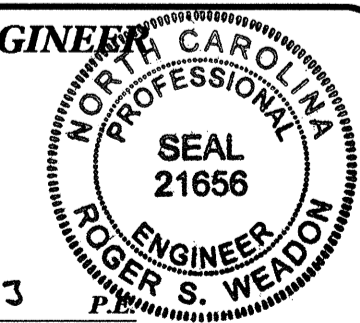

Signature: *Ry We* 10/17/13  
 SIGNATURE: ROGER S. WEADON  
 P.E.

ROADWAY DESIGN ENGINEER



Signature: *Gary R. Lovering*  
 SIGNATURE: GARY R. LOVERING  
 P.E.

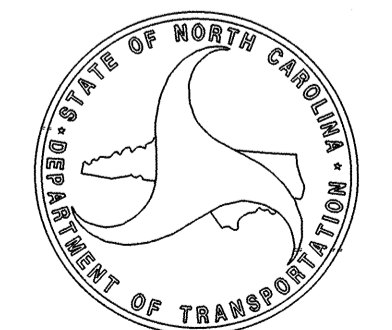

15-OCT-2013 08:30  
R:\Roadway\Proj\B5111\_Rdy\_tsh.dgn  
\$\$\$\$\$USERNAME\$\$\$\$\$

**CONTRACT: C203300**



Note: Not to Scale  
 \*S.U.E. = Subsurface Utility Engineering

# STATE OF NORTH CAROLINA DIVISION OF HIGHWAYS

## CONVENTIONAL PLAN SHEET SYMBOLS

### BOUNDARIES AND PROPERTY:

State Line	-----
County Line	-----
Township Line	-----
City Line	-----
Reservation Line	-----
Property Line	-----
Existing Iron Pin	g
Property Corner	----->
Property Monument	F <sub>ECM</sub>
Parcel/Sequence Number	(123)
Existing Fence Line	-x-x-x-
Proposed Woven Wire Fence	o
Proposed Chain Link Fence	□
Proposed Barbed Wire Fence	◇
Existing Wetland Boundary	WBA
Proposed Wetland Boundary	WBA
Existing Endangered Animal Boundary	EAB
Existing Endangered Plant Boundary	EPB
Known Soil Contamination: Area or Site	☠ ☠
Potential Soil Contamination: Area or Site	☠ ☠

### BUILDINGS AND OTHER CULTURE:

Gas Pump Vent or U/G Tank Cap	V
Sign	S
Well	W
Small Mine	M
Foundation	□
Area Outline	□
Cemetery	y
Building	□
School	x
Church	Y
Dam	□

### HYDROLOGY:

Stream or Body of Water	~~~~~
Hydro, Pool or Reservoir	□
Jurisdictional Stream	JS
Buffer Zone 1	BZ 1
Buffer Zone 2	BZ 2
Flow Arrow	Z
Disappearing Stream	>
Spring	W
Wetland	K
Proposed Lateral, Tail, Head Ditch	← ROW
False Sump	◇

### RAILROADS:

Standard Gauge	-----
RR Signal Milepost	CSX TRANSPORTATION MILEPOST 35
Switch	SWITCH
RR Abandoned	-----
RR Dismantled	-----

### RIGHT OF WAY:

Baseline Control Point	◆
Existing Right of Way Marker	h
Existing Right of Way Line	-----
Proposed Right of Way Line	⊙
Proposed Right of Way Line with Iron Pin and Cap Marker	⊙ ▲
Proposed Right of Way Line with Concrete or Granite R/W Marker	⊙ ▲
Proposed Control of Access Line with Concrete C/A Marker	⊙ ▲
Existing Control of Access	⋮
Proposed Control of Access	⊙
Existing Easement Line	E
Proposed Temporary Construction Easement	E
Proposed Temporary Drainage Easement	TDE
Proposed Permanent Drainage Easement	PDE
Proposed Permanent Drainage / Utility Easement	DUE
Proposed Permanent Utility Easement	PUE
Proposed Temporary Utility Easement	TUE
Proposed Aerial Utility Easement	AUE
Proposed Permanent Easement with Iron Pin and Cap Marker	◆

### ROADS AND RELATED FEATURES:

Existing Edge of Pavement	-----
Existing Curb	-----
Proposed Slope Stakes Cut	C
Proposed Slope Stakes Fill	F
Proposed Curb Ramp	CR
Existing Metal Guardrail	T T T T
Proposed Guardrail	T T T T
Existing Cable Guiderail	□ □ □ □
Proposed Cable Guiderail	□ □ □ □
Equality Symbol	⊙
Pavement Removal	⊗
VEGETATION:	
Single Tree	X
Single Shrub	Y
Hedge	~~~~~
Woods Line	~~~~~

Orchard	☼ ☼ ☼ ☼
Vineyard	Vineyard

### EXISTING STRUCTURES:

MAJOR:	
Bridge, Tunnel or Box Culvert	CONC
Bridge Wing Wall, Head Wall and End Wall	CONC WW
MINOR:	
Head and End Wall	CONC HW
Pipe Culvert	-----
Footbridge	-----
Drainage Box: Catch Basin, DI or JB	CB
Paved Ditch Gutter	-----
Storm Sewer Manhole	m
Storm Sewer	s

### UTILITIES:

POWER:	
Existing Power Pole	P
Proposed Power Pole	o
Existing Joint Use Pole	R
Proposed Joint Use Pole	o
Power Manhole	p
Power Line Tower	l
Power Transformer	}
U/G Power Cable Hand Hole	□
H-Frame Pole	o-o
Recorded U/G Power Line	-----
Designated U/G Power Line (S.U.E.*)	-----

### TELEPHONE:

Existing Telephone Pole	Q
Proposed Telephone Pole	o
Telephone Manhole	i
Telephone Booth	e
Telephone Pedestal	b
Telephone Cell Tower	/
U/G Telephone Cable Hand Hole	] ]
Recorded U/G Telephone Cable	-----
Designated U/G Telephone Cable (S.U.E.*)	-----
Recorded U/G Telephone Conduit	-----
Designated U/G Telephone Conduit (S.U.E.*)	-----
Recorded U/G Fiber Optics Cable	-----
Designated U/G Fiber Optics Cable (S.U.E.*)	-----

### WATER:

Water Manhole	4
Water Meter	a
Water Valve	l
Water Hydrant	H
Recorded U/G Water Line	-----
Designated U/G Water Line (S.U.E.*)	-----
Above Ground Water Line	AG Water

### TV:

TV Satellite Dish	r
TV Pedestal	
TV Tower	l
U/G TV Cable Hand Hole	] ]
Recorded U/G TV Cable	-----
Designated U/G TV Cable (S.U.E.*)	-----
Recorded U/G Fiber Optic Cable	-----
Designated U/G Fiber Optic Cable (S.U.E.*)	-----

### GAS:

Gas Valve	c
Gas Meter	n
Recorded U/G Gas Line	-----
Designated U/G Gas Line (S.U.E.*)	-----
Above Ground Gas Line	AG Gas

### SANITARY SEWER:

Sanitary Sewer Manhole	d
Sanitary Sewer Cleanout	o
U/G Sanitary Sewer Line	SS
Above Ground Sanitary Sewer	AG Sanitary Sewer
Recorded SS Forced Main Line	-----
Designated SS Forced Main Line (S.U.E.*)	-----

### MISCELLANEOUS:

Utility Pole	O
Utility Pole with Base	F
Utility Located Object	S
Utility Traffic Signal Box	3
Utility Unknown U/G Line	-----
U/G Tank; Water, Gas, Oil	□
Underground Storage Tank, Approx. Loc.	Ust
AG Tank; Water, Gas, Oil	□
Geoenvironmental Boring	⊗
U/G Test Hole (S.U.E.*)	?
Abandoned According to Utility Records	AATUR
End of Information	E.O.I.



6/22/99

PROJECT REFERENCE NO. <b>B-5111</b>	SHEET NO. <b>2</b>
ROADWAY DESIGN ENGINEER <b>GARY R. LOVERING</b> SEAL 25873	PAVEMENT DESIGN ENGINEER <b>CLARENCE S. MORRISON</b> SEAL 22886

PAVEMENT SCHEDULE (FINAL PAVEMENT DESIGN, JUNE 20, 2011) (REVISED E1, SEPTEMBER 22, 2013)	
C1	PROP. APPROX. 1 1/4" ASPHALT CONCRETE SURFACE COURSE, TYPE SF9.5A, AT AN AVERAGE RATE OF 137.5 LBS. PER SQ. YD.
C2	PROP. APPROX. 2 1/2" ASPHALT CONCRETE SURFACE COURSE, TYPE SF9.5A, AT AN AVERAGE RATE OF 137.5 LBS. PER SQ. YD. IN EACH OF TWO LAYERS.
C3	PROP. VAR. DEPTH ASPHALT CONCRETE SURFACE COURSE, TYPE SF9.5A, AT AN AVERAGE RATE OF 110 LBS. PER SQ. YD. PER 1" DEPTH. TO BE PLACED IN LAYERS NOT LESS THAN 1" OR GREATER THAN 1 1/2" IN DEPTH.
E1	PROP. APPROX. 5" ASPHALT CONCRETE BASE COURSE, TYPE B25.0B, AT AN AVERAGE RATE OF 570 LBS. PER SQ. YD.
E2	PROP. VAR. DEPTH ASPHALT CONCRETE BASE COURSE, TYPE B25.0B, AT AN AVERAGE RATE OF 114 LBS. PER SQ. YD. PER 1" DEPTH. TO BE PLACED IN LAYERS NOT LESS THAN 4" IN DEPTH OR GREATER THAN 5 1/2" IN DEPTH.
R1	SHOULDER BERM GUTTER.
T	EARTH MATERIAL.
U	EXISTING PAVEMENT.
W	VARIABLE DEPTH ASPHALT PAVEMENT (SEE STANDARD WEDGING DETAIL)

NOTE: PAVEMENT EDGE SLOPES ARE 1:1 UNLESS SHOWN OTHERWISE.

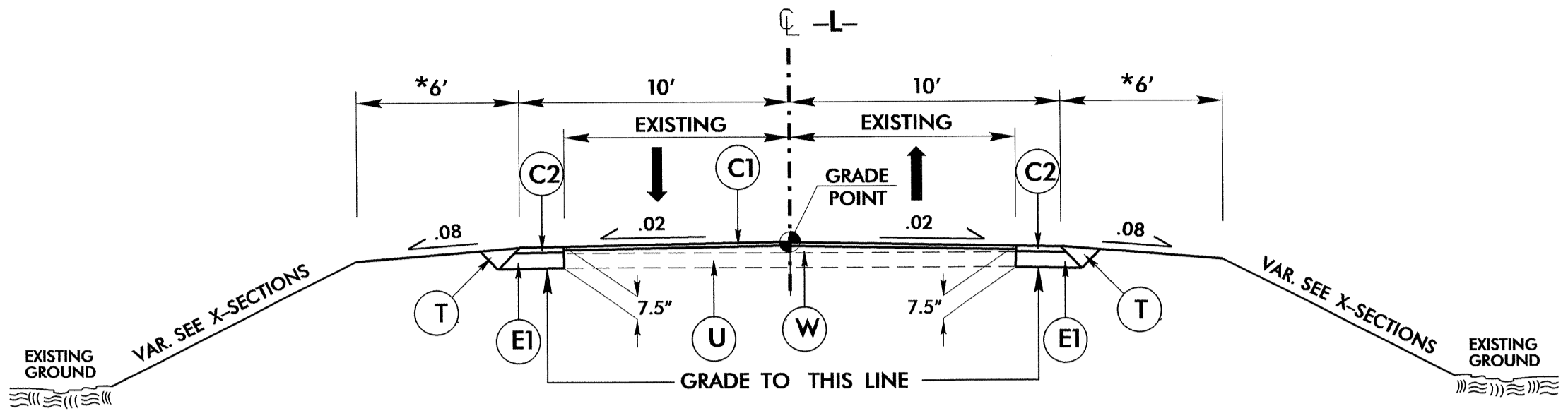

TYPICAL SECTION NO. 1

-L- STA. 19+00.00 TO -L- STA. 19+80.00  
-L- STA. 21+50.00 TO -L- STA. 22+00.00

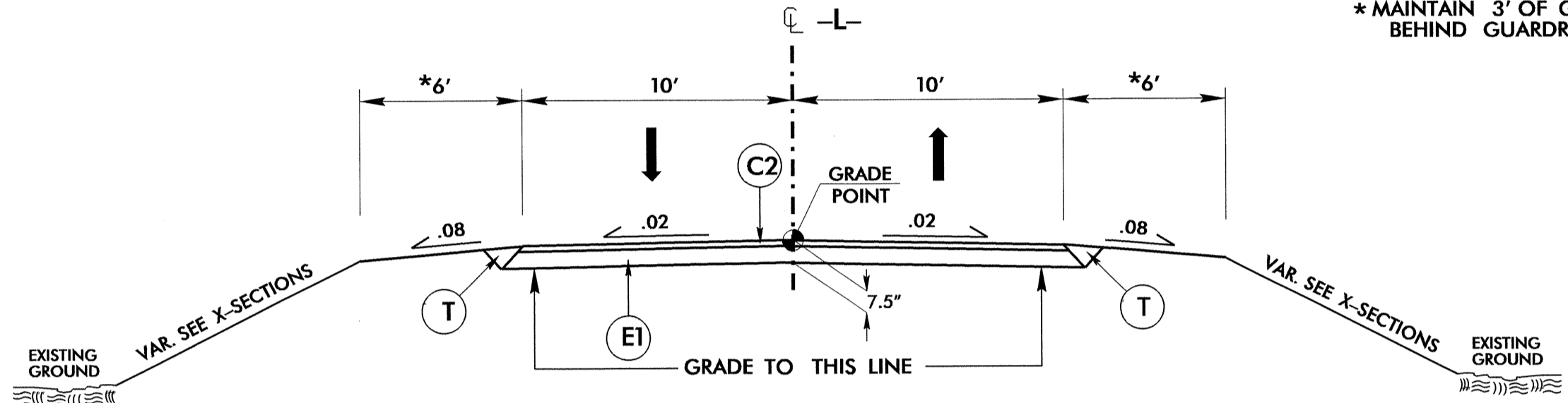

TYPICAL SECTION NO. 2

-L- STA. 19+80.00 TO -L- STA. 20+08.74 (BEGIN BRIDGE)  
-L- STA. 21+26.26 (END BRIDGE) TO -L- STA. 21+50.00

\* MAINTAIN 3' OF GRADED SHOULDER BEHIND GUARDRAIL INSTALLATION

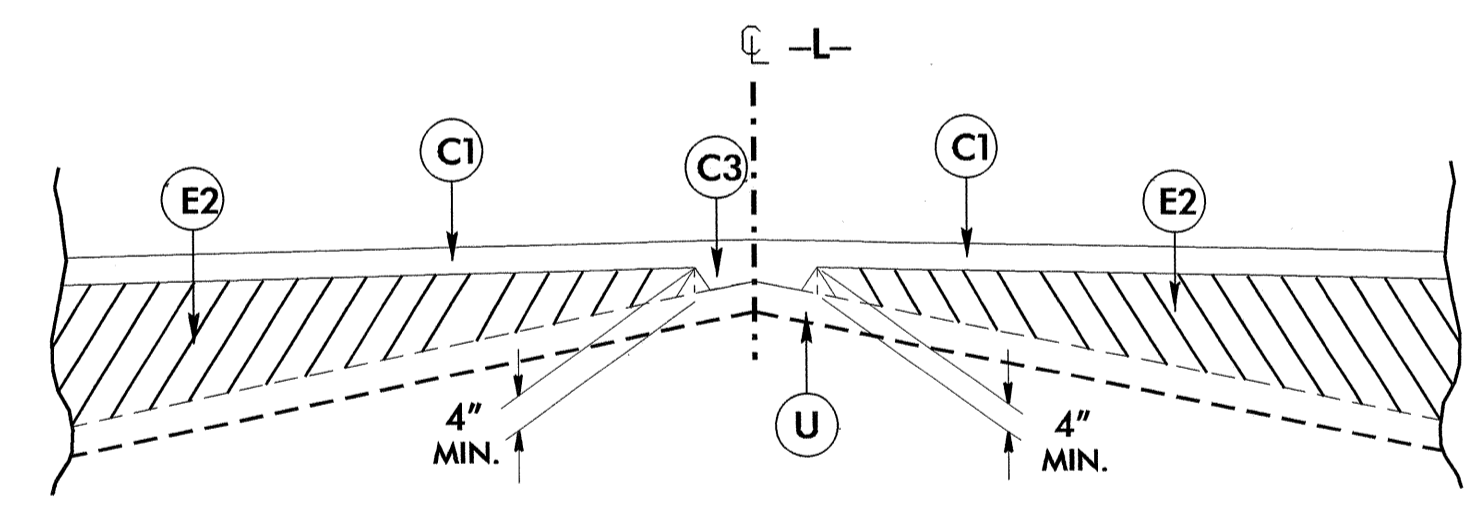

STANDARD WEDGING DETAIL

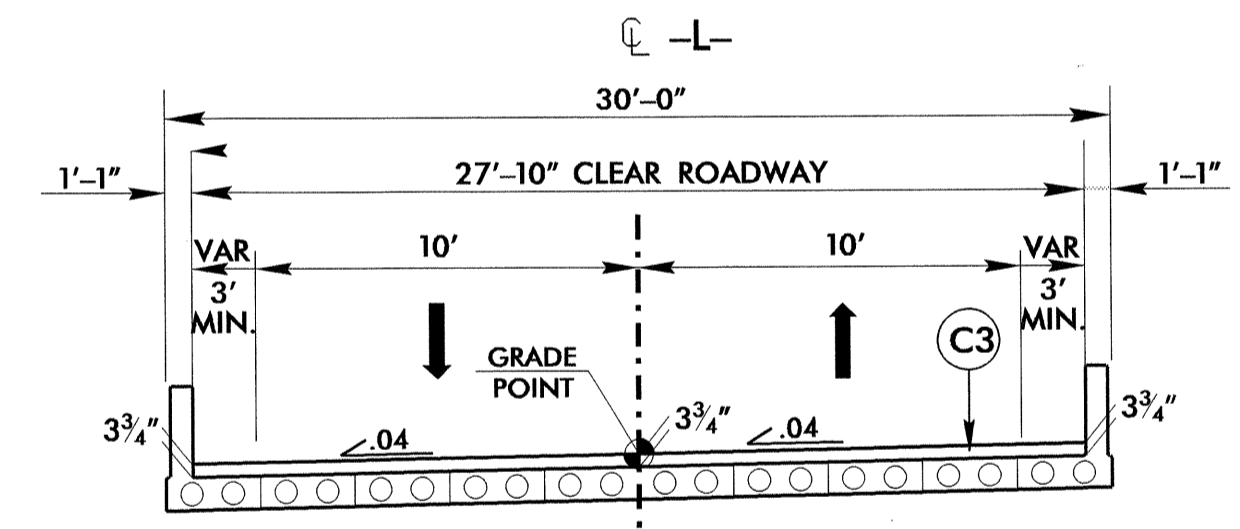

TYPICAL SECTION NO. 3

-L- STA. 20+08.74 (BEGIN BRIDGE) TO -L- STA. 21+26.26 (END BRIDGE)

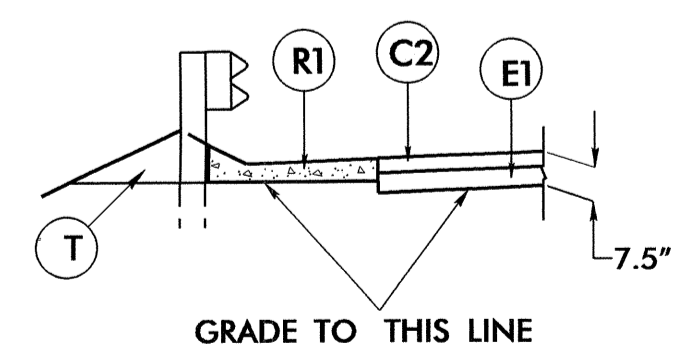

DETAIL SHOWING SHOULDER BERM GUTTER ON TOP OF SUBGRADE

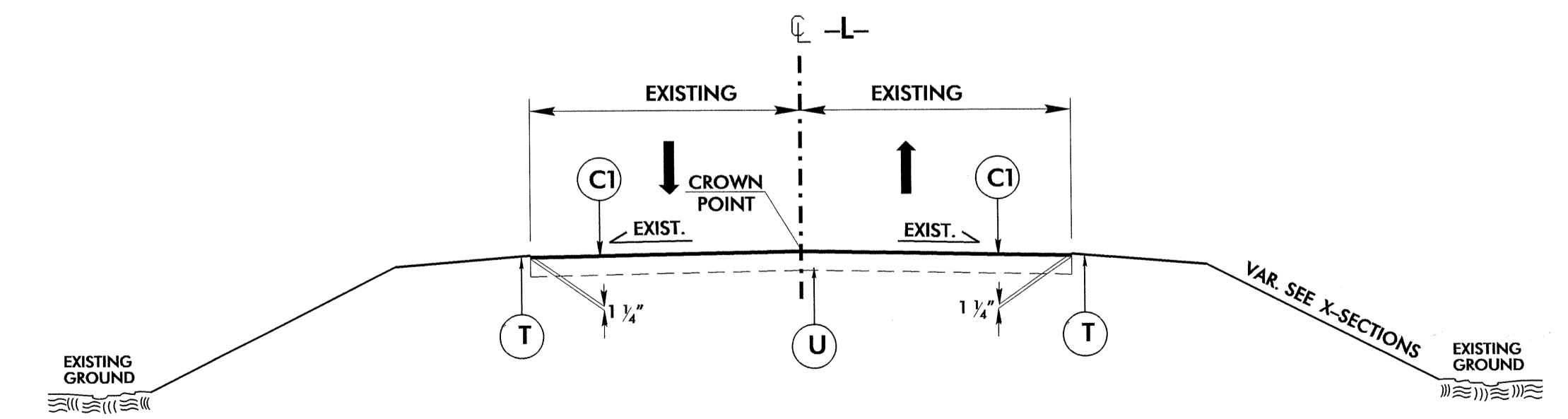

TYPICAL SECTION NO. 4

-L- STA. 22+00.00 TO -L- STA. 22+20.00

-L- STA. 19+80.16 TO -L- STA. 19+97.23 (BEGIN APPROACH SLAB) LT.  
-L- STA. 21+37.77 (END APPROACH SLAB) TO -L- STA. 21+51.76 LT.

15-OCT-2013 08:30  
R:\Roadway\Projects\B5111-Fdy-tyr.dgn  
5:51:18 PM





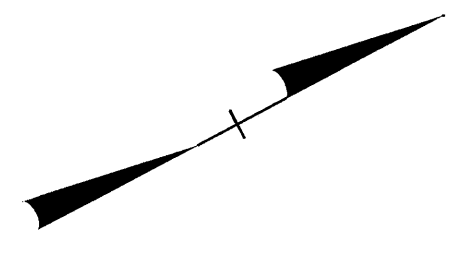

-L-  
 PI Sta 23+04.51  
 $\Delta = 23^{\circ} 30' 13.5''$  (LT)  
 $D = 2^{\circ} 58' 35.1''$   
 $L = 789.67'$   
 $T = 400.47'$   
 $R = 1,925.00'$   
 $SE = 04$   
 RUNOFF = SEE PLANS

**BEGIN TIP PROJECT B-5111**  
 -L- POT STA. 19+00.00

**END TIP PROJECT B-5111**  
 -L- POC STA. 22+20.00

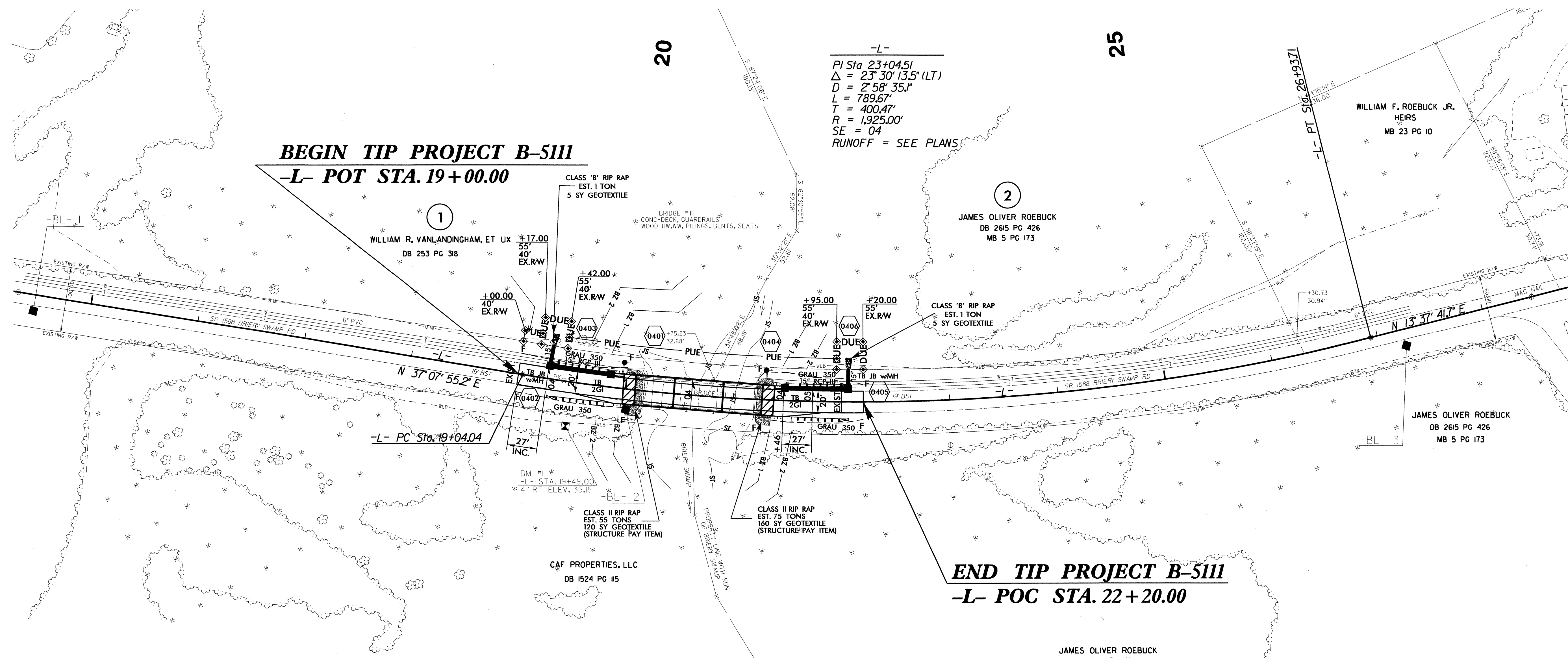

NOTE: DESIGN EXCEPTION REQUIRED  
 FOR MINIMUM HORIZONTAL  
 STOPPING SIGHT DISTANCE OF 376'.

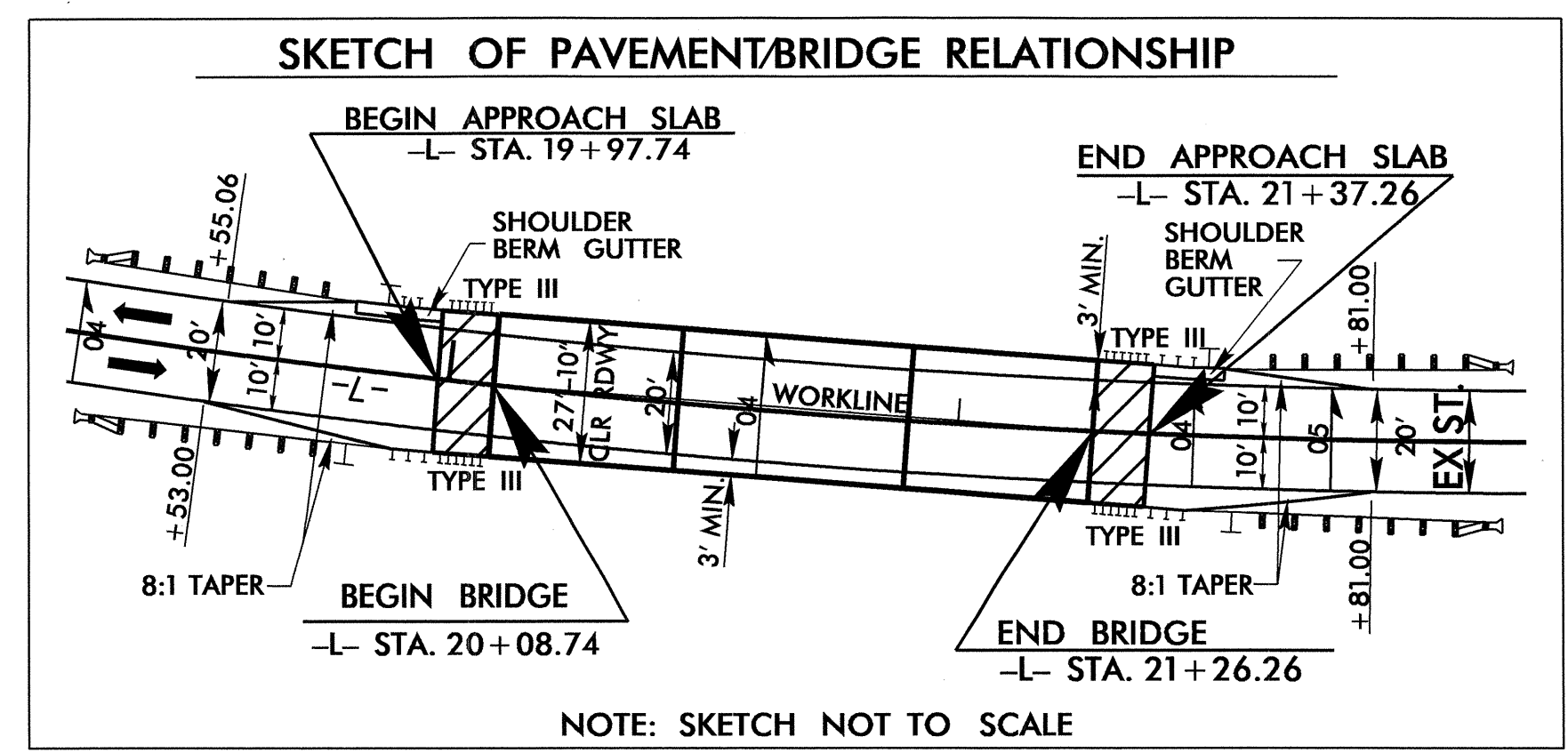



BRIDGE APPROACH SLAB

NOTES:  
 1) SEE SHEET 5 FOR -L- PROFILE  
 2) SEE SHEETS S-1 THROUGH S-20 FOR STRUCTURE PLANS

09-OCT-2013 10:45  
 R:\Roadwork\proj\B5111\_rdw\_psh\_s4.dgn  
 5/14/99



5/14/99

PROJECT REFERENCE NO. <b>B-5111</b>	SHEET NO. <b>5</b>
ROADWAY DESIGN ENGINEER 	HYDRAULICS ENGINEER 
<i>Cary R. Lovering</i>	<i>Roger S. Weidner 10/17/13</i>

**STRUCTURE HYDRAULIC DATA**

DESIGN DISCHARGE = 1200 CFS  
 DESIGN FREQUENCY = 25 YRS  
 DESIGN HW ELEVATION = 33.9 FT  
 BASE DISCHARGE = 1800 CFS  
 BASE FREQUENCY = 100 YRS  
 BASE HW ELEVATION = 34.7 FT  
 OVERTOPPING DISCHARGE = 2900 CFS  
 OVERTOPPING FREQUENCY = 500+ YRS  
 OVERTOPPING ELEVATION = 35.4 FT  
 DATE OF SURVEY = DECEMBER 2011  
 W.S. ELEVATION AT DATE OF SURVEY = 31.9 +/- FT

**-L-**

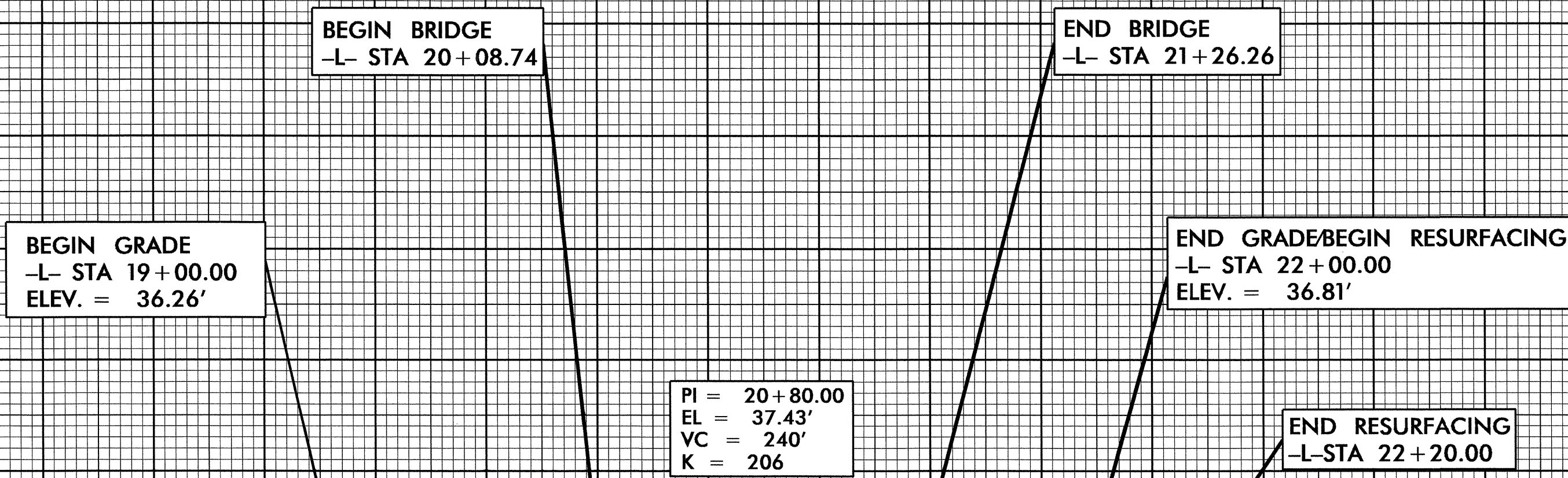

UNCLASSIFIED STRUCTURE EXCAVATION (STRUCTURE PAY ITEM)

UNCLASSIFIED STRUCTURE EXCAVATION (STRUCTURE PAY ITEM)

CLASS II RIP RAP (STRUCTURE PAY ITEM)

CLASS II RIP RAP (STRUCTURE PAY ITEM)

**BM #1**  
-L- STA. 19+49.00 41' RT  
ELEV. = 35.15'

**NOTES:**  
 1) SEE SHEET 4 FOR -L- PLAN  
 2) SEE SHEETS S-1 THROUGH S-20 FOR STRUCTURE PLANS

09-OCT-2013 09:39  
R:\Roadway\Proj\B5111\_Rdy\_psh.pfl\_s5.dgn

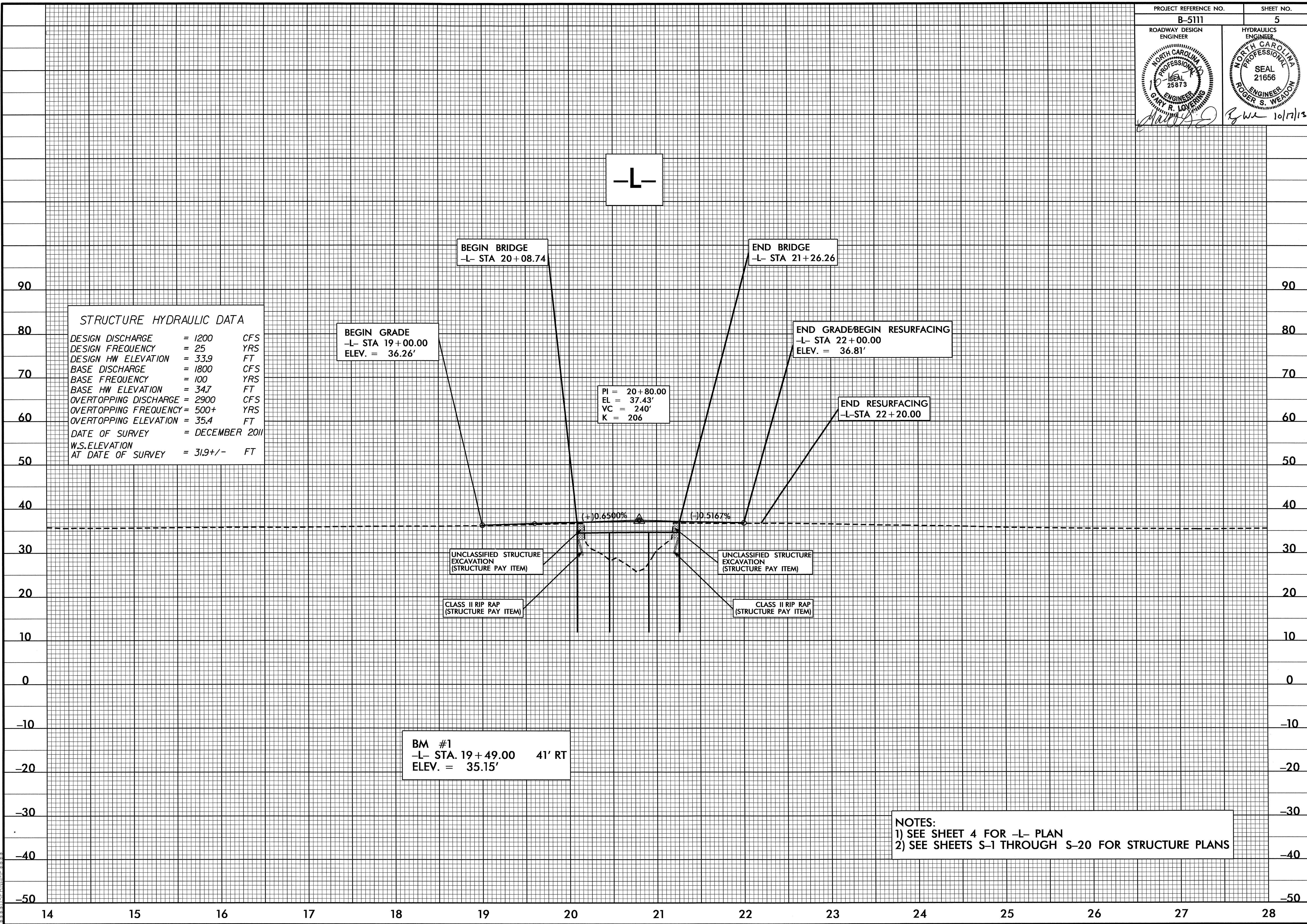

STATE OF NORTH CAROLINA  
DIVISION OF HIGHWAYS

**TRANSPORTATION MANAGEMENT PLAN**

**PITT COUNTY**

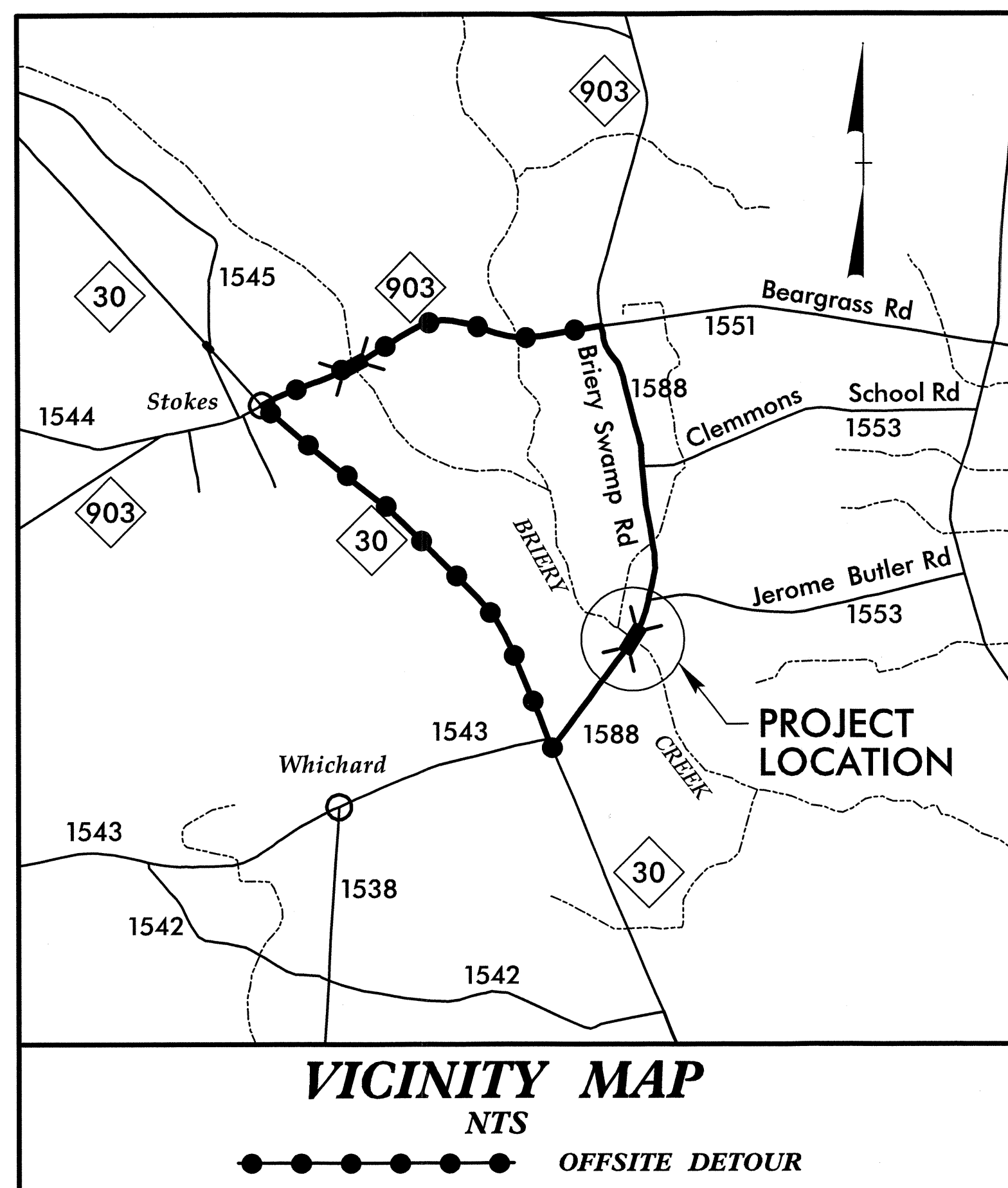

**LOCATION: BRIDGE NO. III OVER BRIERY SWAMP  
ON SR 1588**

**TYPE OF WORK: GRADING, DRAINAGE, PAVING AND  
STRUCTURE**

**INDEX OF SHEETS**

SHEET NO.	TITLE
TMP-1	TITLE SHEET, VICINITY MAP, AND INDEX OF SHEETS
TMP-1A	LIST OF APPLICABLE ROADWAY STANDARD DRAWINGS AND LEGEND
TMP-1B	TRANSPORTATION OPERATIONS PLAN: (MANAGEMENT STRATEGIES, GENERAL NOTES, LOCAL NOTES, AND PHASING)
TMP-2	SPECIAL SIGN DESIGN
TMP-3	OFF-SITE DETOUR
TMP-4	ROAD CLOSURE

SHEET NO.  
TMP-1

**B-5111**

**TIP PROJECT:**

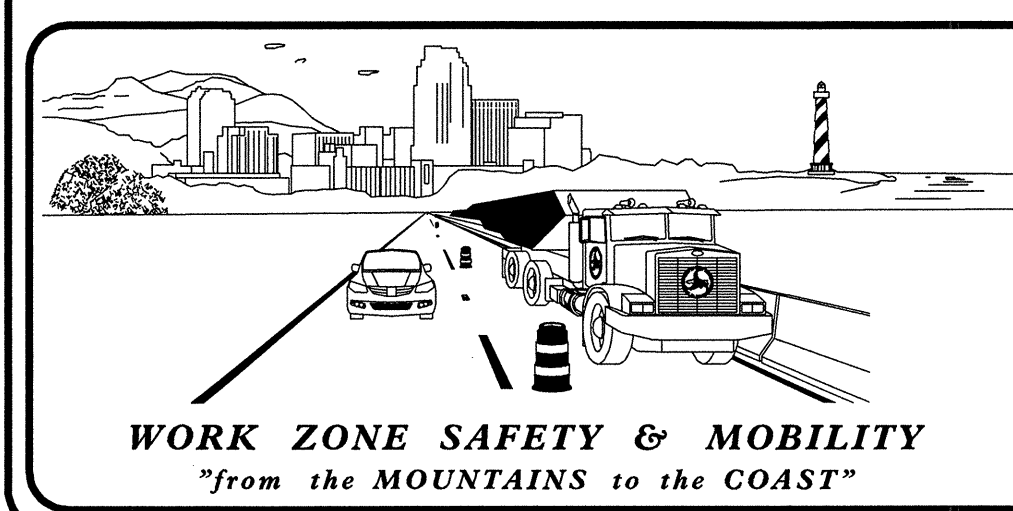

**N.C.D.O.T. WORK ZONE TRAFFIC CONTROL**  
1561 MAIL SERVICE CENTER (MSC) RALEIGH, NC 27699-1561  
750 N. GREENFIELD PARKWAY, GARNER, NC 27529 (DELIVERY)  
PHONE: (919) 773-2800 FAX: (919) 771-2745

J. S. BOURNE, P.E. STATE TRAFFIC MANAGEMENT ENGINEER  
J. S. KITE, P.E. TRAFFIC CONTROL PROJECT ENGINEER  
D. W. BISSETTE, P.E. TRAFFIC CONTROL PROJECT DESIGN ENGINEER  
TRAFFIC CONTROL DESIGN ENGINEER

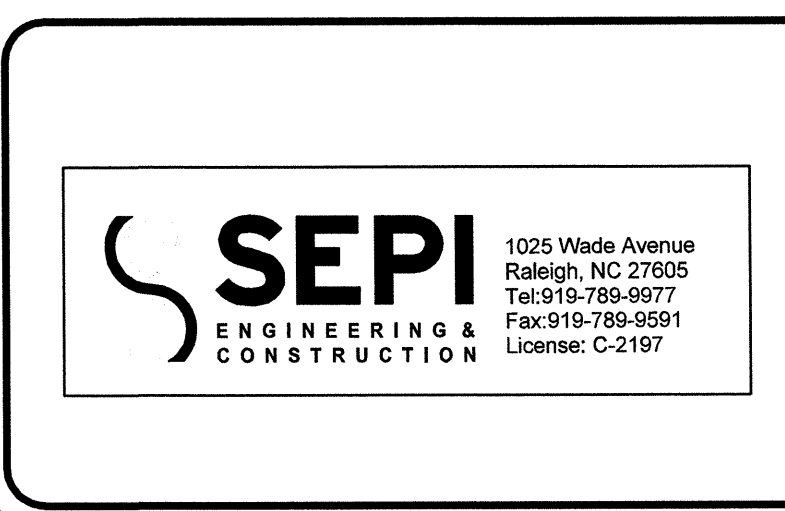
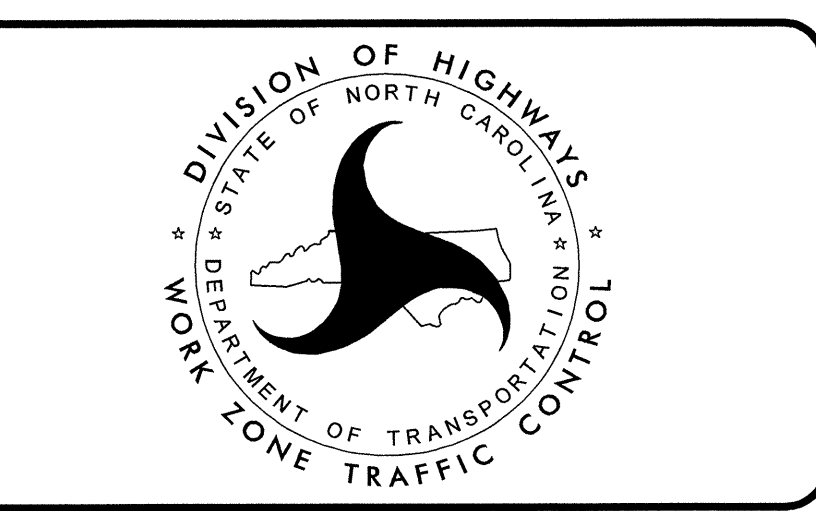

APPROVED: *Stev Miller*  
DATE: 9-3-13

SEAL  
NORTH CAROLINA PROFESSIONAL ENGINEER SEAL 037026  
STEVEN D. MILLER

\$\$\$\$\$SYTIME\$\$\$\$\$  
\$\$\$\$\$USERNAME\$\$\$\$\$

## ROADWAY STANDARD DRAWINGS

THE FOLLOWING ROADWAY STANDARDS AS SHOWN IN "ROADWAY STANDARD DRAWINGS" - PROJECT SERVICES UNIT - N.C. DEPARTMENT OF TRANSPORTATION - RALEIGH, N.C., DATED JANUARY 2012 ARE APPLICABLE TO THIS PROJECT AND BY REFERENCE HEREBY ARE CONSIDERED A PART OF THESE PLANS:

<u>STD. NO.</u>	<u>TITLE</u>
1101.02	TEMPORARY LANE CLOSURES
1101.03	TEMPORARY ROAD CLOSURES
1101.05	WORK ZONE VEHICLE ACCESSES
1101.11	TRAFFIC CONTROL DESIGN TABLES
1110.01	STATIONARY WORK ZONE SIGNS
1145.01	BARRICADES-TYPE III

## LEGEND

### GENERAL

- DIRECTION OF TRAFFIC FLOW
- DIRECTION OF PEDESTRIAN TRAFFIC FLOW
- EXIST. PVMT.
- NORTH ARROW
- PROPOSED PVMT.
- TEMP. SHORING (LOCATION PURPOSES ONLY)

WORK AREA

REMOVAL

USER DEFINED (IF NEEDED)

USER DEFINED (IF NEEDED)

### SIGNALS

- EXISTING
- PROPOSED
- TEMPORARY

### PAVEMENT MARKINGS

- EXISTING LINES
- TEMPORARY LINES

### TRAFFIC CONTROL DEVICES

- BARRICADE (TYPE III)
- CONE
- DRUM SKINNY DRUM TUBULAR MARKER
- TEMPORARY CRASH CUSHION
- FLASHING ARROW BOARD
- FLAGGER
- LAW ENFORCEMENT
- TRUCK MOUNTED ATTENUATOR (TMA)
- CHANGEABLE MESSAGE SIGN

### TEMPORARY SIGNING

- PORTABLE SIGN
- STATIONARY SIGN
- STATIONARY OR PORTABLE SIGN

### PAVEMENT MARKERS

- CRYSTAL/CRYSTAL
- CRYSTAL/RED
- YELLOW/YELLOW

### PAVEMENT MARKING SYMBOLS

- PAVEMENT MARKING SYMBOLS

\$\$\$SYTIME\$\$\$\$\$  
 \$\$\$DGN\$\$\$\$\$  
 \$\$\$USERNAME\$\$\$\$\$

APPROVED:  DATE: 10-31-15		
<h3>ROADWAY STANDARD DRAWINGS &amp; LEGEND</h3>		

## MANAGEMENT STRATEGIES

- CLOSE SR 1588 (BRIERY SWAMP ROAD) AND DETOUR TRAFFIC OFF-SITE
- LOCAL ACCESS TO ALL RESIDENCES AND BUSINESSES WILL BE MAINTAINED BETWEEN CLOSURE POINTS AT ALL TIMES DURING CONSTRUCTION

## GENERAL NOTES

CHANGES MAY BE REQUIRED WHEN PHYSICAL DIMENSIONS IN THE DETAIL DRAWINGS, STANDARD DETAILS, AND ROADWAY DETAILS ARE NOT ATTAINABLE TO MEET FIELD CONDITIONS OR RESULT IN DUPLICATE OR UNDESIRED OVERLAPPING OF DEVICES. MODIFICATION MAY INCLUDE: MOVING, SUPPLEMENTING, COVERING, OR REMOVAL OF DEVICES AS DIRECTED BY THE ENGINEER.

THE FOLLOWING GENERAL NOTES APPLY AT ALL TIMES FOR THE DURATION OF THE CONSTRUCTION PROJECT EXCEPT WHEN OTHERWISE NOTED IN THE PLAN OR DIRECTED BY THE ENGINEER.

### SIGNING

- A) PROVIDE SIGNING AND DEVICES REQUIRED TO CLOSE THE ROAD ACCORDING TO THE ROADWAY STANDARD DRAWINGS AND TRAFFIC MANAGEMENT PLANS.  
  
PROVIDE SIGNING REQUIRED FOR THE OFF-SITE DETOUR ROUTE AS SHOWN IN THE TRAFFIC MANAGEMENT PLANS.
- B) COVER OR REMOVE ALL SIGNS AND DEVICES REQUIRED TO CLOSE THE ROAD WHEN ROAD CLOSURE IS NOT IN OPERATION.  
  
COVER OR REMOVE ALL SIGNS REQUIRED FOR THE OFF-SITE DETOUR WHEN THE DETOUR IS NOT IN OPERATION.
- C) ENSURE ALL NECESSARY SIGNING IS IN PLACE PRIOR TO ALTERING ANY TRAFFIC PATTERN.

## LOCAL NOTES

1. NOTIFY THE ENGINEER AT LEAST ONE MONTH PRIOR TO ANY TRAFFIC PATTERN ALTERATION.
2. NOTIFY PITT COUNTY SCHOOLS AT LEAST ONE MONTH PRIOR TO ROAD CLOSURE.
3. NOTIFY PITT COUNTY EMERGENCY SERVICES AT LEAST ONE MONTH PRIOR TO ROAD CLOSURE.

## PHASING

- STEP 1 USING RSD 1101.02 SHEET 1 OF 15, INSTALL WATER LINE AT THE BRIDGE SITE AS SHOWN IN THE UTILITY PLANS.
- STEP 2 USING RSD 1101.03 SHEET 1 OF 9, CLOSE BRIERY SWAMP ROAD (SR 1588) AND DETOUR TRAFFIC OFF-SITE AS SHOWN ON TMP-3. MAINTAIN ACCESS TO ALL RESIDENCES AND BUSINESSES BETWEEN CLOSURE POINTS.
- STEP 3 REMOVE THE EXISTING STRUCTURE.
- STEP 4 CONSTRUCT THE PROPOSED STRUCTURE AND ROADWAY.
- STEP 5 PLACE FINAL PAVEMENT MARKINGS ACCORDING TO THE PAVEMENT MARKING PLANS.
- STEP 6 OPEN BRIERY SWAMP ROAD (SR 1588) TO TRAFFIC AND REMOVE ALL TRAFFIC CONTROL DEVICES.

\$\$\$SYTIME\$\$\$\$\$  
 \$\$\$SDGN\$\$\$\$\$  
 \$\$\$USERNAME\$\$\$\$\$

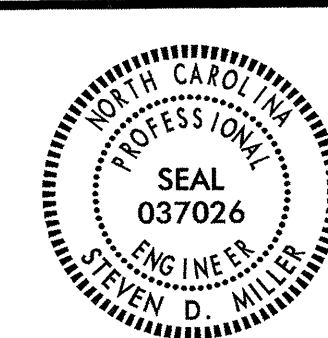
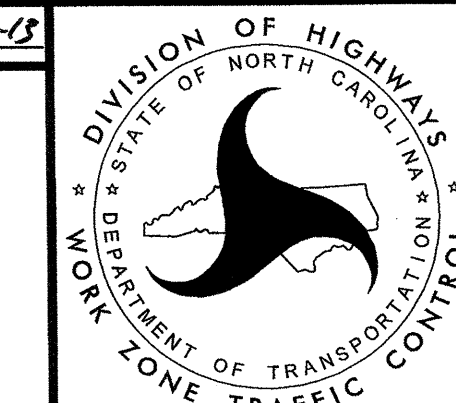
APPROVED: <i>St. Miller</i> DATE: 10-31-13			<h1 style="margin: 0;">TRANSPORTATION OPERATIONS PLAN</h1>
--	---	---	--



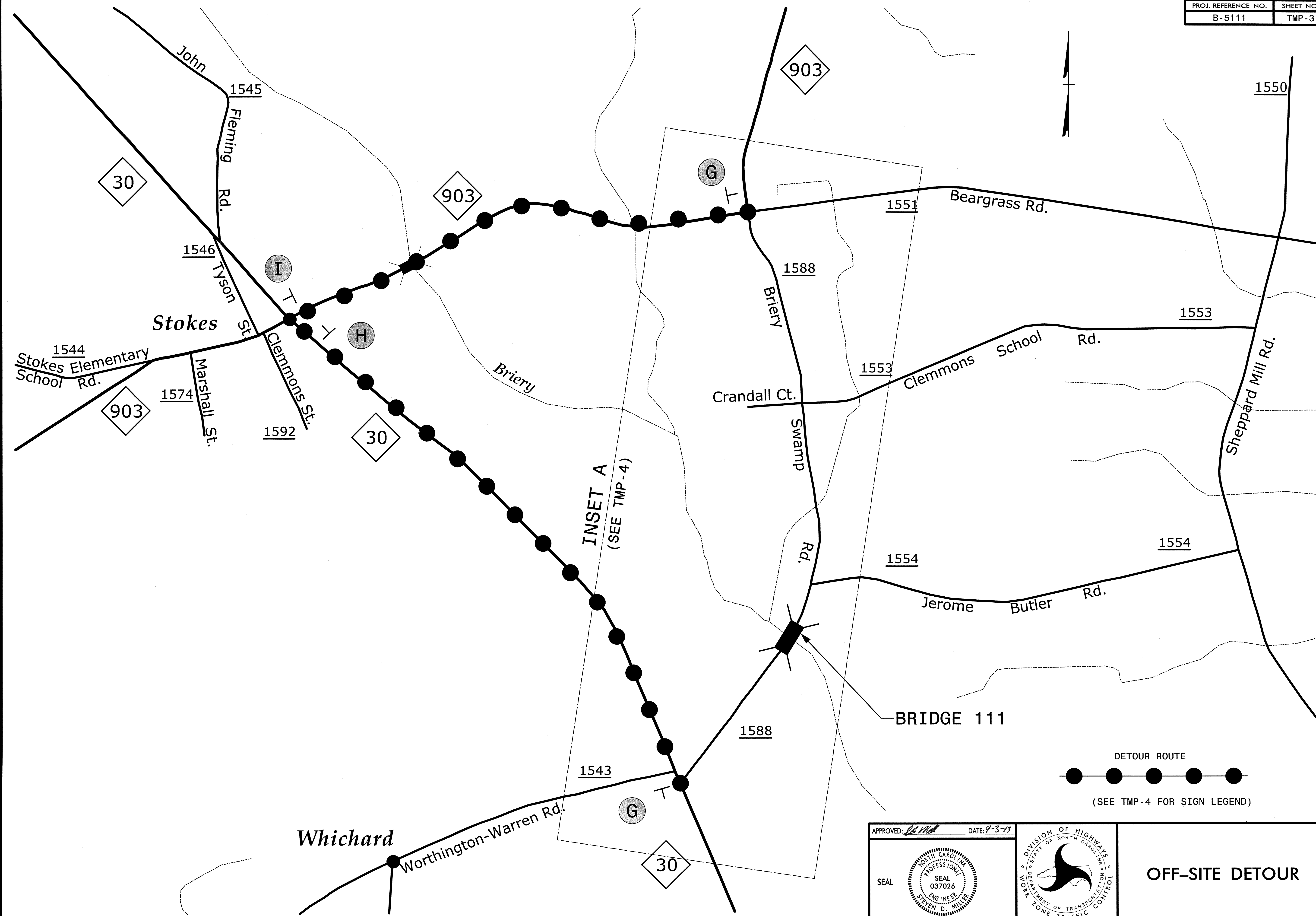

INSET A  
(SEE TMP-4)

DETOUR ROUTE  
(SEE TMP-4 FOR SIGN LEGEND)

APPROVED: *[Signature]* DATE: 9-3-15

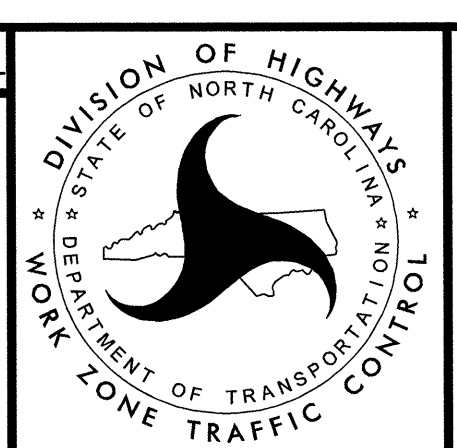

**OFF-SITE DETOUR**



STATE OF NORTH CAROLINA  
DEPARTMENT OF TRANSPORTATION

TIP NO. B-5111	SHEET NO. PMP-1
APPROVED: <i>[Signature]</i>	
DATE: 9-19-13	
SEAL	

PAVEMENT MARKING PLAN  
PITT COUNTY

LOCATION: BRIDGE NO. III OVER BRIERY CREEK ON SR 1588

T.I.P.: B-5111

CONTRACT: C203300

ROADWAY STANDARD DRAWING

THE FOLLOWING ROADWAY STANDARDS AS APPEAR IN "ROADWAY STANDARD DRAWINGS" - PROJECT SERVICES UNIT - N.C. DEPARTMENT OF TRANSPORTATION - RALEIGH, N.C., DATED JANUARY 2012 ARE APPLICABLE TO THIS PROJECT AND BY REFERENCE HEREBY ARE CONSIDERED A PART OF THESE PLANS:

STD. NO.	TITLE
1205.01	PAVEMENT MARKINGS - LINE TYPES AND OFFSETS
1205.02	PAVEMENT MARKINGS - TWO-LANE AND MULTILANE ROADWAYS
1205.12	PAVEMENT MARKINGS - BRIDGES
1261.01	GUARDRAIL AND BARRIER DELINEATORS - INSTALLATION SPACING
1261.02	GUARDRAIL AND BARRIER DELINEATORS - TYPES AND MOUNTING
1262.01	GUARDRAIL END DELINEATION

GENERAL NOTES

THE FOLLOWING GENERAL NOTES APPLY AT ALL TIMES FOR THE DURATION OF THE CONSTRUCTION PROJECT, EXCEPT WHEN OTHERWISE NOTED IN THE PLAN, OR DIRECTED BY THE ENGINEER.

A) INSTALL PAVEMENT MARKINGS AND PAVEMENT MARKERS ON THE FINAL SURFACE AS FOLLOWS:

ROAD NAME	MARKING	MARKER
-L- LINE	PAINT	NONE
BRIDGE DECK	PAINT	NONE

B) PLACE TWO APPLICATIONS OF PAINT PAVEMENT MARKINGS ON THE FINAL WEARING SURFACE. PLACE THE SECOND APPLICATION OF PAINT UPON SUFFICIENT DRYING TIME OF THE FIRST.

C) TIE PROPOSED PAVEMENT MARKING LINES TO EXISTING PAVEMENT MARKING LINES.

D) REMOVE/REPLACE ANY CONFLICTING/DAMAGED PAVEMENT MARKINGS AND MARKERS.

E) PASSING ZONES WILL BE DETERMINED IN THE FIELD AND MUST BE APPROVED BY THE ENGINEER.

PAVEMENT MARKING DETAIL

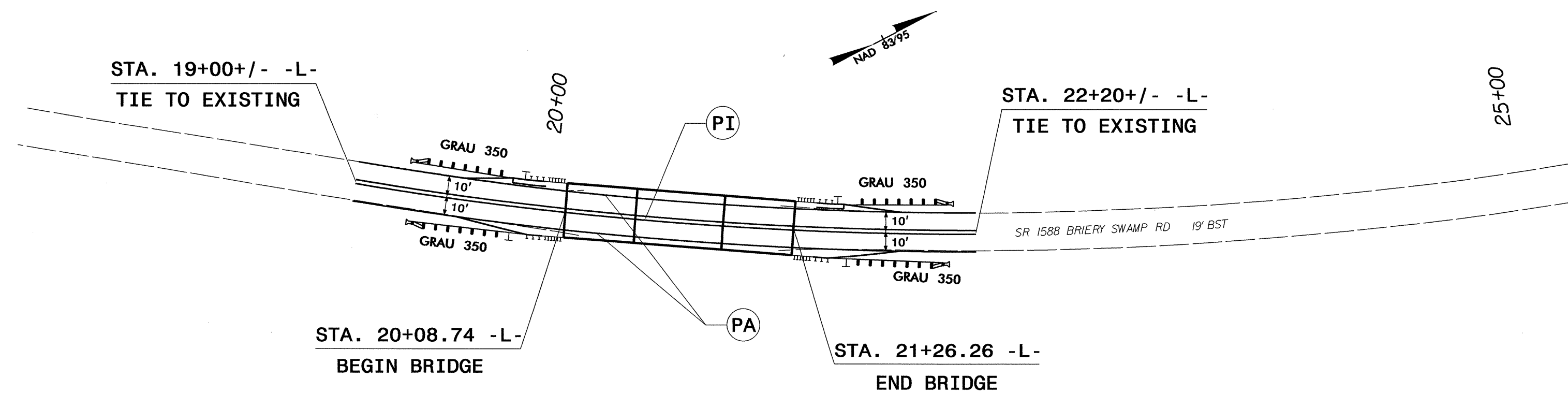

PAVEMENT MARKING SCHEDULE

SYMBOL	DESCRIPTION
PA	WHITE EDGELINE (4")
PI	YELLOW DOUBLE CENTER (4")

INDEX

SHEET NO.	DESCRIPTION
PMP-1	PAVEMENT MARKING PLAN TITLE, NOTES, DETAIL, AND SCHEDULE SHEET

PLAN PREPARED BY: N.C.D.O.T. SIGNING AND DELINEATION UNIT

A. I. ALQUDWAH, P.E. SIGNING & DELINEATION REGIONAL ENGINEER  
D. M. EATON SIGNING & DELINEATION PROJECT DESIGN ENGINEER

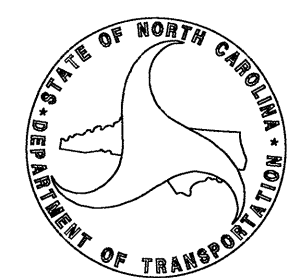



**TIP PROJECT: B-5111**

STATE OF NORTH CAROLINA  
 DIVISION OF HIGHWAYS  
 PLAN FOR PROPOSED  
 HIGHWAY EROSION CONTROL  
**PITT COUNTY**

**LOCATION: BRIDGE NO. 111 OVER BRIERY SWAMP ON SR 1588**  
**TYPE OF WORK: GRADING, DRAINAGE, PAVING, AND STRUCTURE**

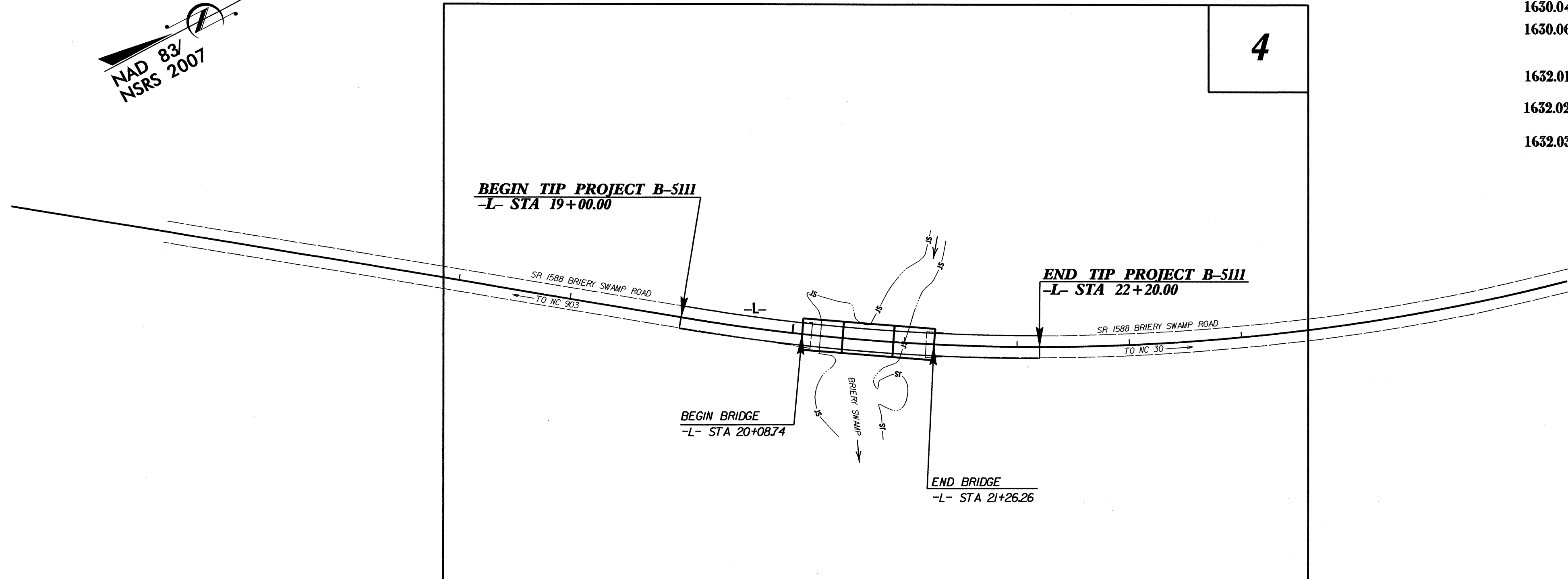
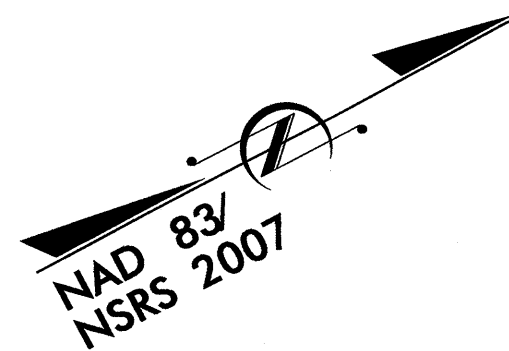

STATE	STATE PROJECT REFERENCE NO.	SHEET NO.	TOTAL SHEETS
N.C.	B-5111	EC-1	
STATE PROJ. NO.	F.A. PROJ. NO.	DESCRIPTION	

**EROSION AND SEDIMENT CONTROL MEASURES**

Std. #	Description	Symbol
1630.05	Temporary Silt Ditch	TD
1630.05	Temporary Diversion	TD
1605.01	Temporary Silt Fence	TSF
1606.01	Special Sediment Control Fence	TSF
1622.01	Temporary Berms and Slope Drains	TBD
1630.02	Silt Basin Type B	Silt Basin
1633.01	Temporary Rock Silt Check Type-A	Rock Silt Check
	Temporary Rock Silt Check Type-A with Matting and Polyacrylamide (PAM)	Rock Silt Check with PAM
1633.02	Temporary Rock Silt Check Type-B	Rock Silt Check
	Wattle / Coir Fiber Wattle	Wattle
	Wattle / Coir Fiber Wattle with Polyacrylamide (PAM)	Wattle with PAM
1634.01	Temporary Rock Sediment Dam Type-A	Rock Sediment Dam
1634.02	Temporary Rock Sediment Dam Type-B	Rock Sediment Dam
1635.01	Rock Pipe Inlet Sediment Trap Type-A	Rock Inlet Trap
1635.02	Rock Pipe Inlet Sediment Trap Type-B	Rock Inlet Trap
1630.04	Stilling Basin	Stilling Basin
1630.06	Special Stilling Basin	Special Stilling Basin
	Rock Inlet Sediment Trap:	
1632.01	Type A	A
1632.02	Type B	B
1632.03	Type C	C
	Skimmer Basin	Skimmer Basin
	Tiered Skimmer Basin	Tiered Skimmer Basin
	Infiltration Basin	Infiltration Basin

**THIS PROJECT CONTAINS EROSION CONTROL PLANS FOR CLEARING AND GRUBBING PHASE OF CONSTRUCTION.**

**THIS PROJECT HAS BEEN DESIGNED TO SENSITIVE WATERSHED STANDARDS.**

**ENVIRONMENTALLY SENSITIVE AREA(S) EXIST ON THIS PROJECT**  
 Refer To E. C. Special Provisions for Special Considerations.

**GRAPHIC SCALE**

0  
  
 PLANS

0  
  
 PROFILE (HORIZONTAL)

0  
  
 PROFILE (VERTICAL)

ROADSIDE ENVIRONMENTAL UNIT  
 DIVISION OF HIGHWAYS  
 STATE OF NORTH CAROLINA

THESE EROSION AND SEDIMENT CONTROL PLANS COMPLY WITH THE REGULATIONS SET FORTH BY THE NCG-010000 GENERAL CONSTRUCTION PERMIT EFFECTIVE AUGUST 3, 2011 ISSUED BY THE NORTH CAROLINA DEPARTMENT OF ENVIRONMENT AND NATURAL RESOURCES DIVISION OF WATER QUALITY.

Prepared in the Office of:  
**ROADSIDE ENVIRONMENTAL UNIT**  
 1 South Wilmington St.  
 Raleigh, NC 27611  
**2012 STANDARD SPECIFICATIONS**

**Roadway Standard Drawings**

The following roadway english standards as appear in "Roadway Standard Drawings"- Roadway Design Unit - N. C. Department of Transportation - Raleigh, N. C., dated January 2012 and the latest revision thereto are applicable to this project and by reference hereby are considered a part of these plans.

1604.01 Railroad Erosion Control Detail	1632.01 Rock Inlet Sediment Trap Type A
1605.01 Temporary Silt Fence	1632.02 Rock Inlet Sediment Trap Type B
1606.01 Special Sediment Control Fence	1632.03 Rock Inlet Sediment Trap Type C
1607.01 Gravel Construction Entrance	1633.01 Temporary Rock Silt Check Type A
1622.01 Temporary Berms and Slope Drains	1633.02 Temporary Rock Silt Check Type B
1630.01 Riser Basin	1634.01 Temporary Rock Sediment Dam Type A
1630.02 Silt Basin Type B	1634.02 Temporary Rock Sediment Dam Type B
1630.03 Temporary Silt Ditch	1635.01 Rock Pipe Inlet Sediment Trap Type A
1630.04 Stilling Basin	1635.02 Rock Pipe Inlet Sediment Trap Type B
1630.05 Temporary Diversion	1640.01 Coir Fiber Baffle
1630.06 Special Stilling Basin	1645.01 Temporary Stream Crossing
1631.01 Matting Installation	

25-SEP-2013 15:33  
 R:\Projects\2013\1533\Roadway\Drawings\1533-111-EC.dgn  
 w:\shahad\1 - AT - 1533-111-EC.dgn

# SILT FENCE COIR FIBER WATTLE BREAK DETAIL

PROJECT REFERENCE NO.		SHEET NO.	
B-5111		EC-2	
RW SHEET NO.			
ROADWAY DESIGN ENGINEER		HYDRAULICS ENGINEER	

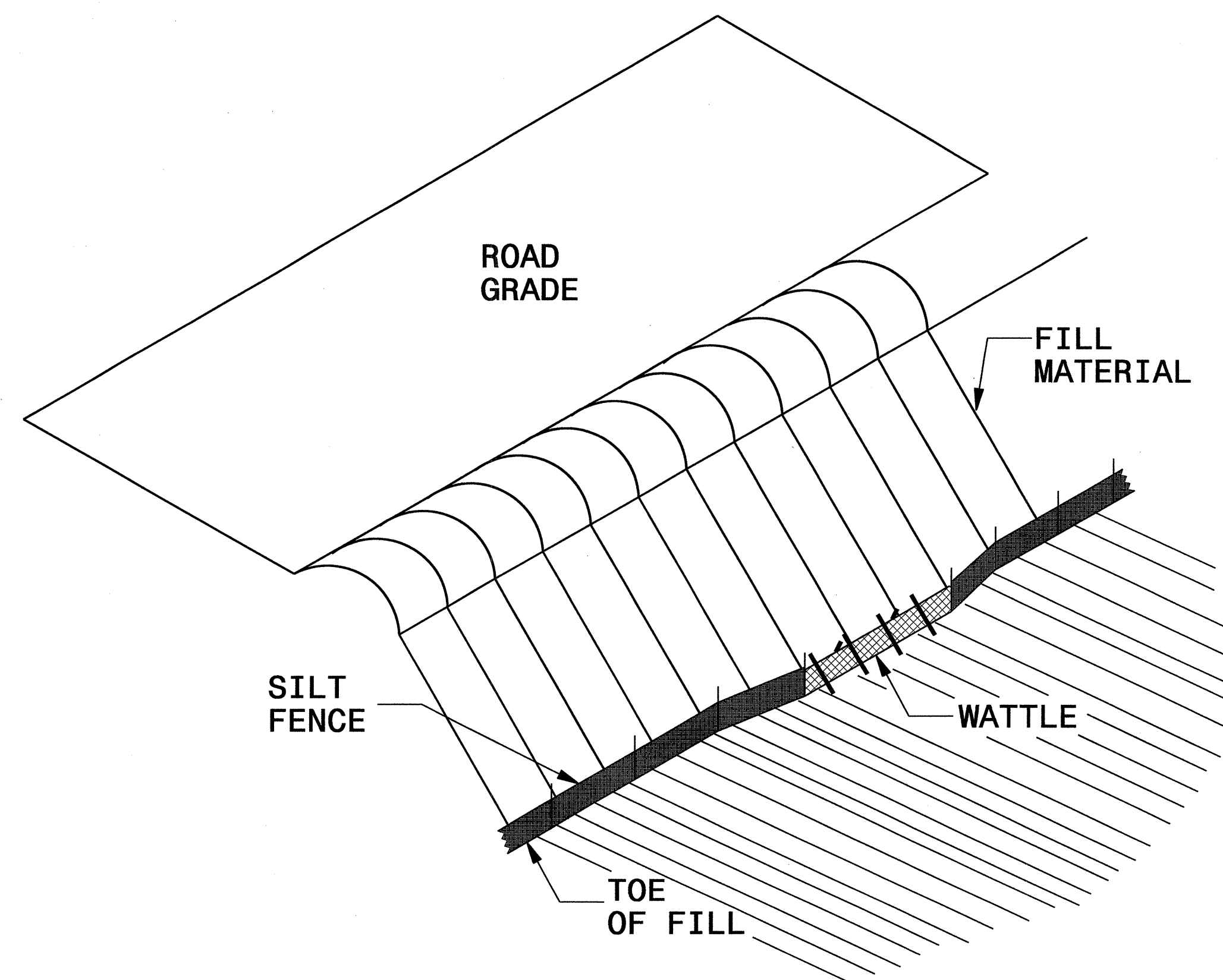

**ISOMETRIC VIEW**

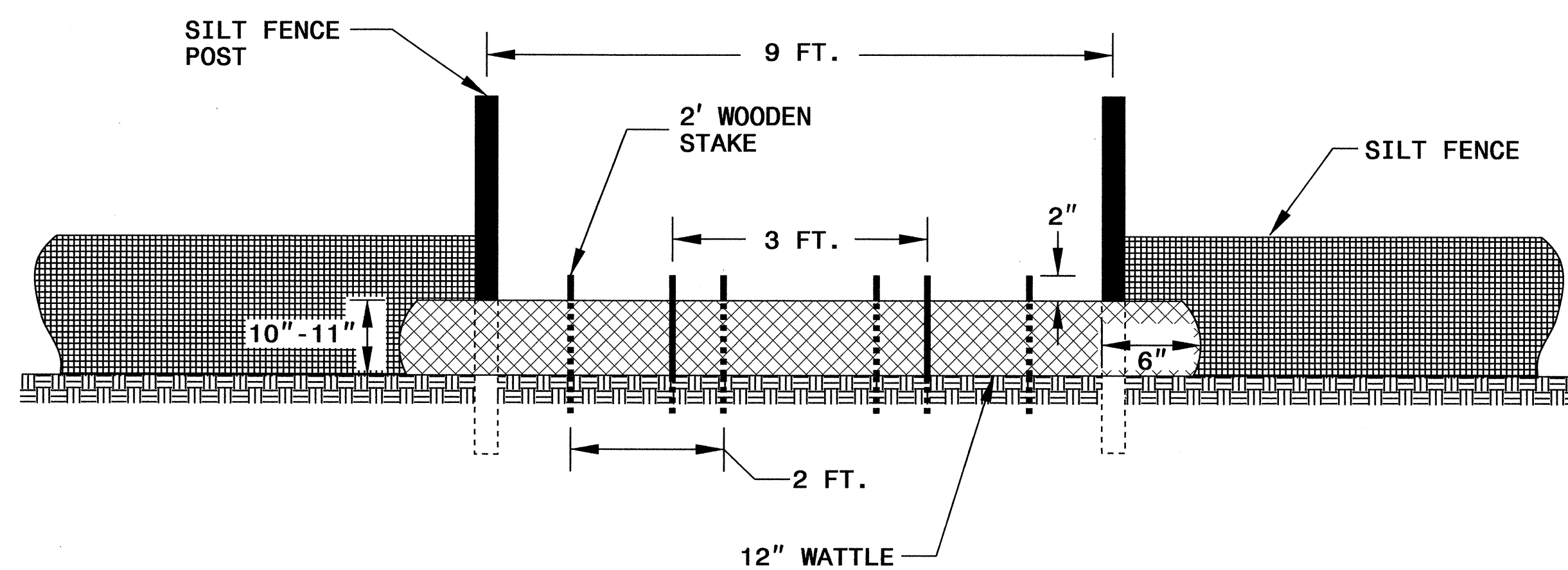

**VIEW FROM SLOPE**

**NOTES:**

- USE MINIMUM 12 IN. DIAMETER COIR FIBER (COCONUT FIBER) WATTLE AND LENGTH OF 10 FT.
- EXCAVATE A 1 TO 2 INCH TRENCH FOR WATTLE TO BE PLACED.
- DO NOT PLACE WATTLE ON TOE OF SLOPE.
- USE 2 FT. WOODEN STAKES WITH A 2 IN. BY 2 IN. NOMINAL CROSS SECTION.
- INSTALL A MINIMUM OF 2 UPSLOPE STAKES AND 4 DOWNSLOPE STAKES AT AN ANGLE TO WEDGE WATTLE TO GROUND.
- PROVIDE STAPLES MADE OF 0.125 IN. DIAMETER STEEL WIRE FORMED INTO A U SHAPE NOT LESS THAN 12" IN LENGTH.
- INSTALL STAPLES APPROXIMATELY EVERY 1 LINEAR FOOT ON BOTH SIDES OF WATTLE AND AT EACH END TO SECURE IT TO THE SOIL.
- WATTLE INSTALLATION CAN BE ON OUTSIDE OF THE SILT FENCE AS DIRECTED.
- INSTALL TEMPORARY SILT FENCE IN ACCORDANCE WITH SECTION 1605 OF THE STANDARD SPECIFICATIONS.

**INSET A**

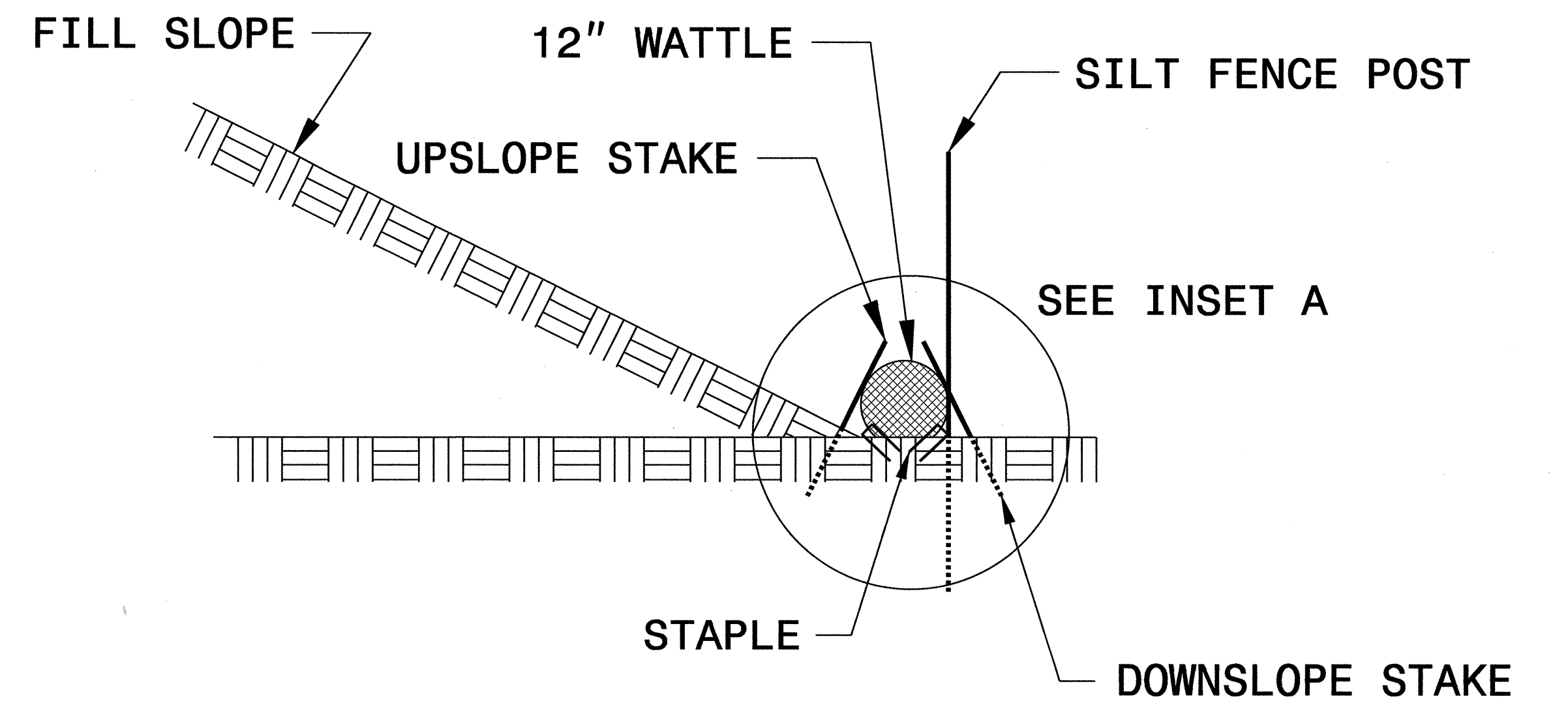
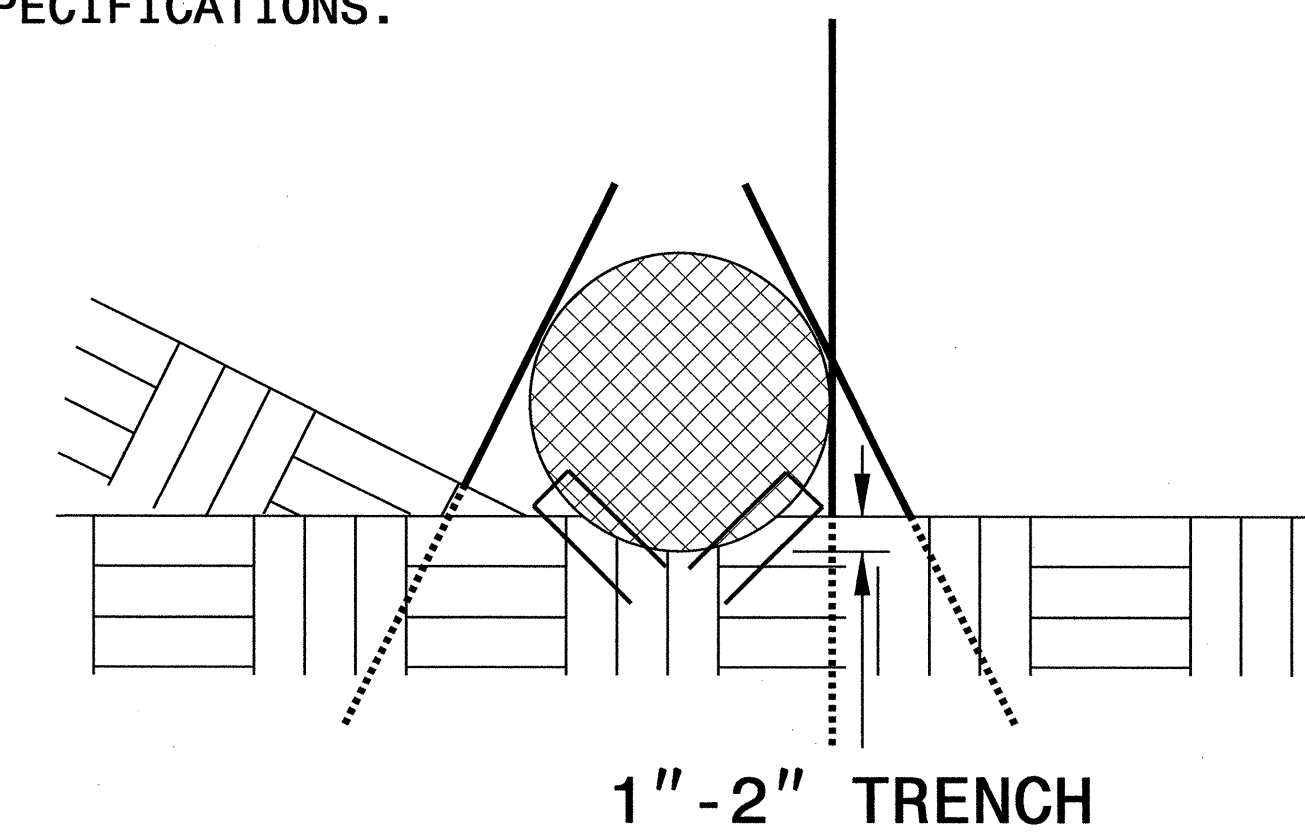

**SIDE VIEW**

DIVISION OF HIGHWAYS  
STATE OF NORTH CAROLINA

---



---

PROJECT REFERENCE NO. <i>B-5111</i>	SHEET NO. <i>EC-3</i>
ROADWAY DESIGN ENGINEER	HYDRAULICS ENGINEER

# ***SOIL STABILIZATION TIMEFRAMES***

<i>SITE DESCRIPTION</i>	<i>STABILIZATION TIME</i>	<i>TIMEFRAME EXCEPTIONS</i>
PERIMETER DIKES, SWALES, DITCHES AND SLOPES	7 DAYS	NONE
HIGH QUALITY WATER (HQW) ZONES	7 DAYS	NONE
SLOPES STEEPER THAN 3:1	7 DAYS	IF SLOPES ARE 10' OR LESS IN LENGTH AND ARE NOT STEEPER THAN 2:1, 14 DAYS ARE ALLOWED.
SLOPES 3:1 OR FLATTER	14 DAYS	7 DAYS FOR SLOPES GREATER THAN 50' IN LENGTH.
ALL OTHER AREAS WITH SLOPES FLATTER THAN 4:1	14 DAYS	NONE, EXCEPT FOR PERIMETERS AND HQW ZONES.

5/14/99

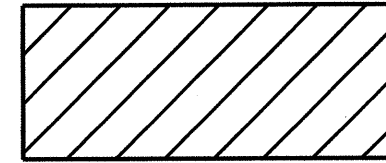

ENVIRONMENTALLY SENSITIVE AREA  
SEE PROJECT SPECIAL PROVISIONS

NOTE: PLACE TEMPORARY ROCK SEDIMENT DAMS TYPE - B AND TEMPORARY ROCK SILT CHECKS TYPE - A AT DRAINAGE OUTLETS.

CLEARING AND GRUBBING EROSION CONTROL FOR CONSTRUCTION SHEET 4

NOTE: UTILIZE SPECIAL STILLING BASIN(S) AS STILLING BASIN WHERE APPLICABLE.

PROJECT REFERENCE NO. <b>B-5111</b>		SHEET NO. <i>EC-4/CONST.4</i>	
RW SHEET NO.			
ROADWAY DESIGN ENGINEER		HYDRAULICS ENGINEER	

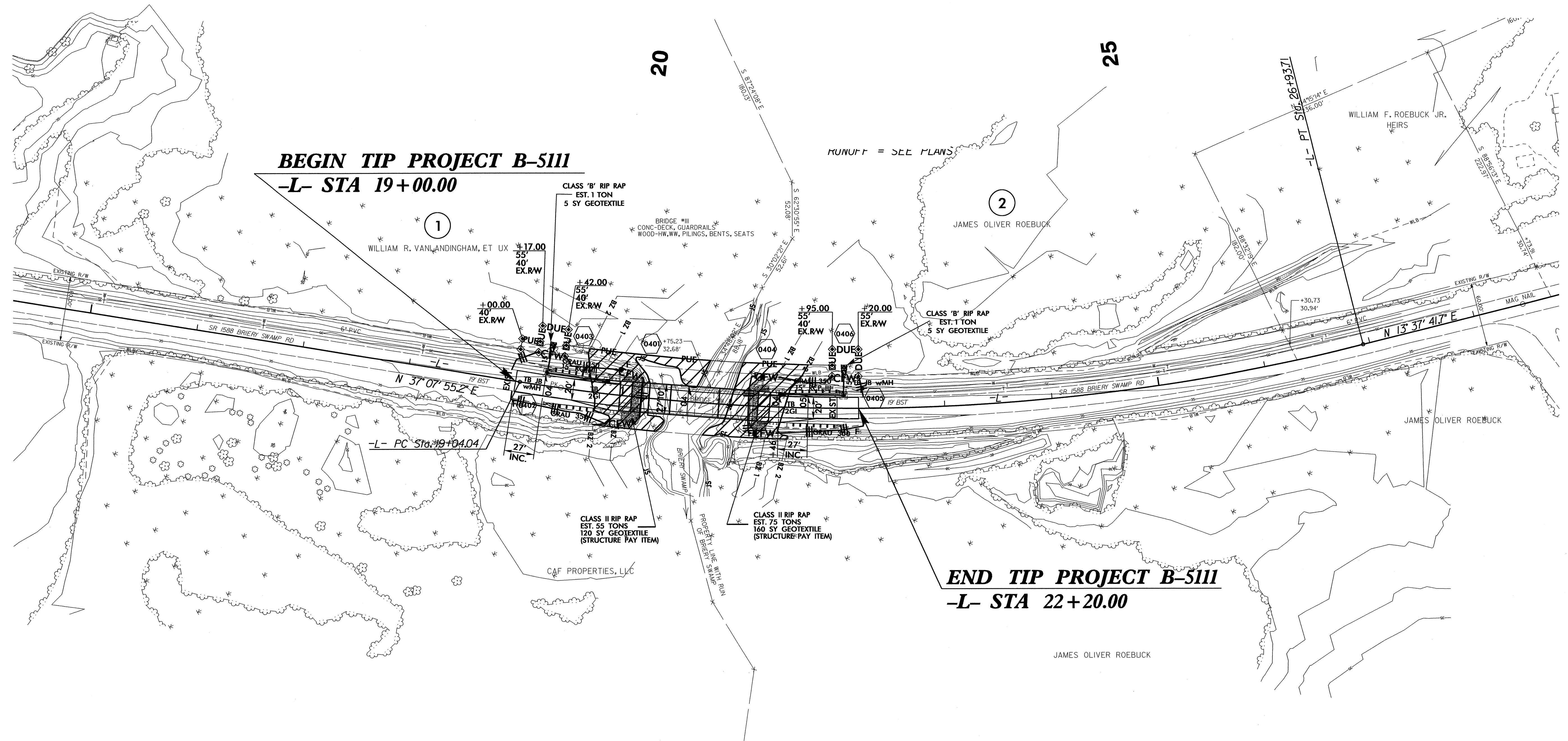

**BEGIN TIP PROJECT B-5111**  
**-L- STA 19+00.00**

**END TIP PROJECT B-5111**  
**-L- STA 22+20.00**

BRIDGE APPROACH SLAB

5/14/99

NOTE:  
UTILIZE SPECIAL STILLING BASIN(S)  
AS STILLING BASIN WHERE APPLICABLE.

PROJECT REFERENCE NO. <b>B-5111</b>		SHEET NO. <i>EC-5/CONST.4</i>	
RW SHEET NO.			
ROADWAY DESIGN ENGINEER		HYDRAULICS ENGINEER	

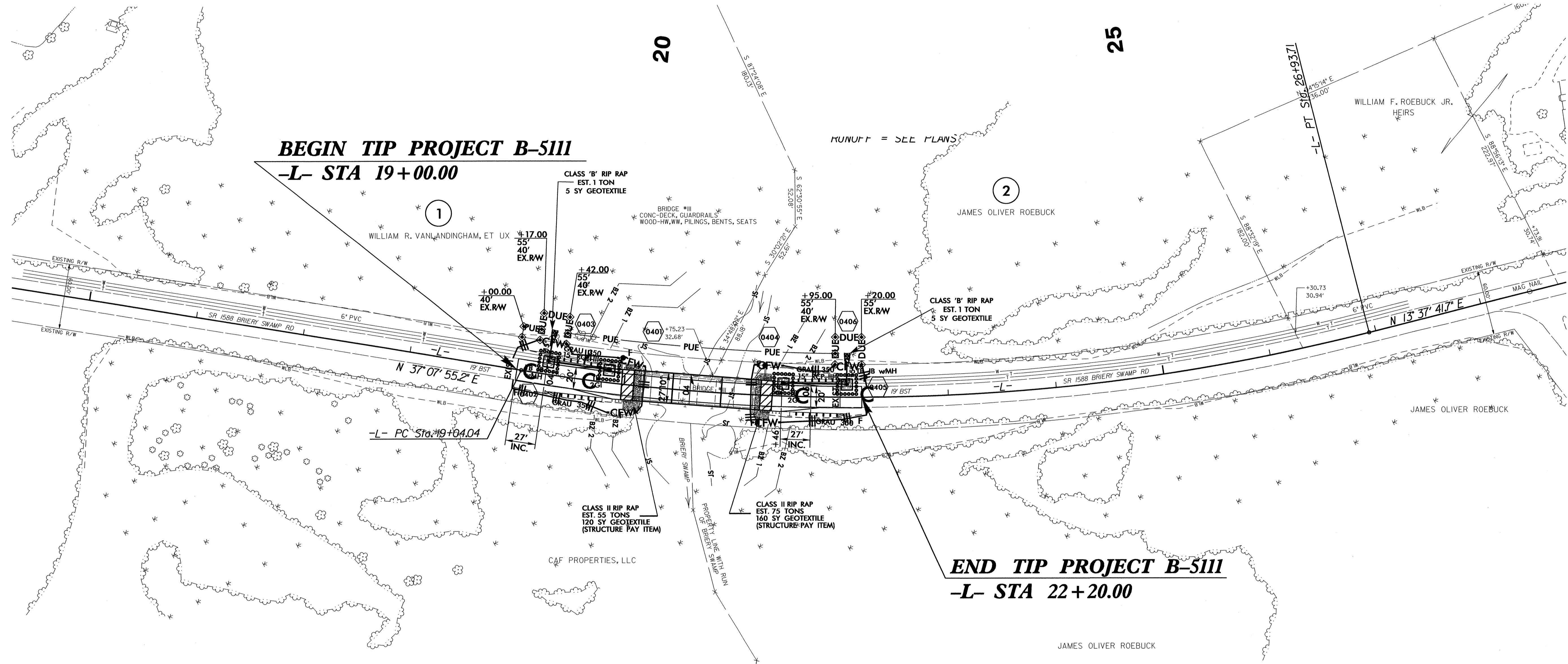
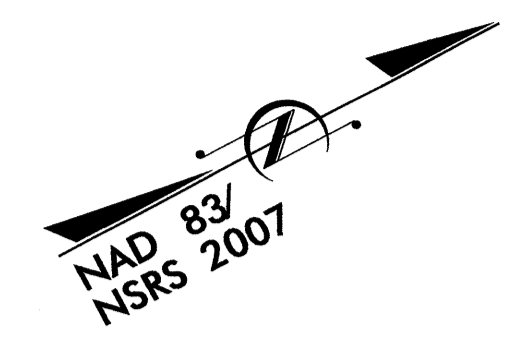

26-SEP-2013 15:36  
 R:\Environment\B-5111-EC-pah4.dgn  
 wjohnson AT REN2778

BRIDGE APPROACH SLAB

## PLANTING DETAILS

### SEEDLING / LINER BAREROOT PLANTING DETAIL

#### HEALING IN

1. Locate a healing-in site in a shady, well protected area.
2. Excavate a flat bottom trench 12 inches deep and provide drainage.

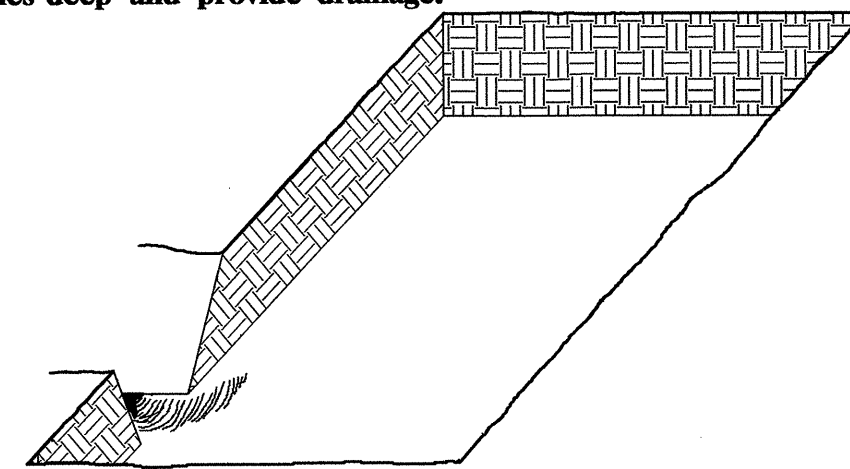

3. Backfill the trench with 2 inches well rotted sawdust. Place a 2 inch layer of well rotted sawdust at a sloping angle at one end of the trench.

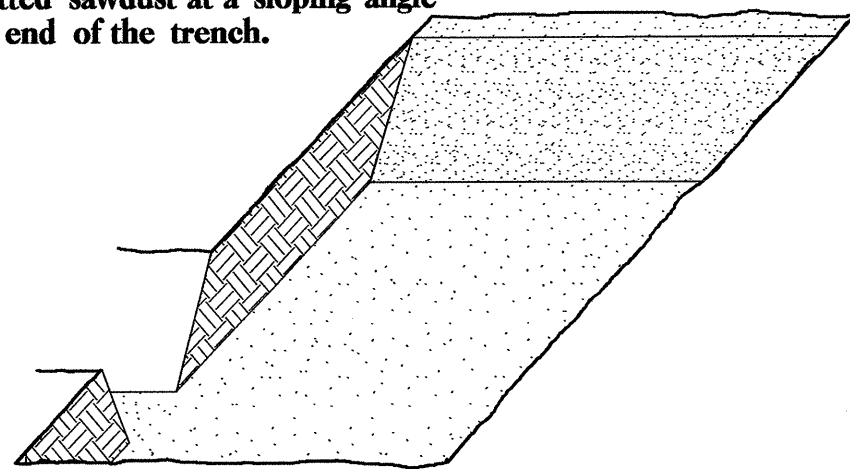

4. Place a single layer of plants against the sloping end so that the root collar is at ground level.

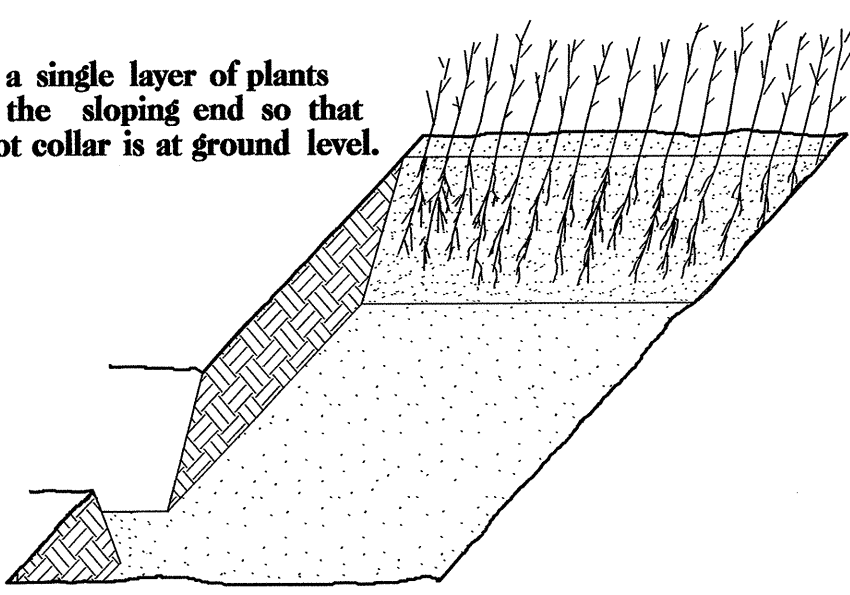

5. Place a 2 inch layer of well rotted sawdust over the roots maintaining a sloping angle.

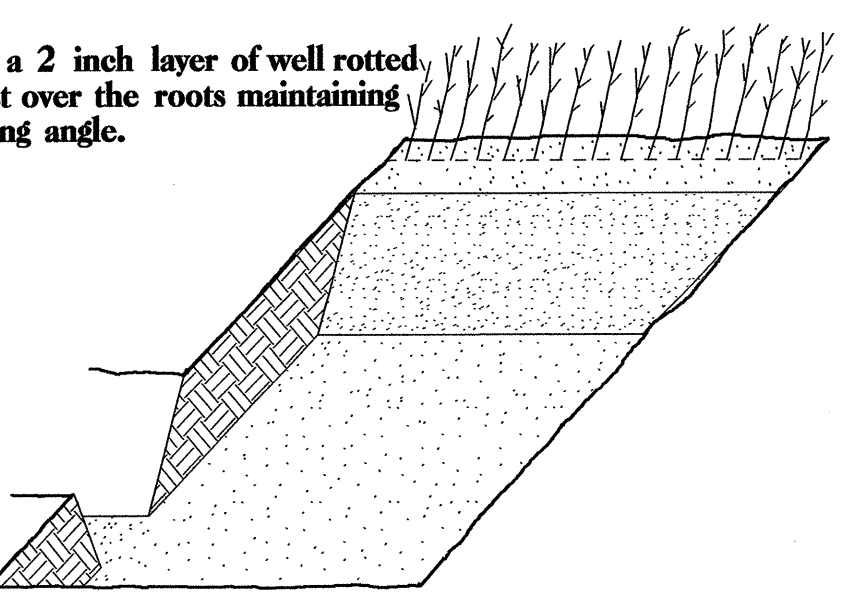

6. Repeat layers of plants and sawdust as necessary and water thoroughly.

#### DIBBLE PLANTING METHOD USING THE KBC PLANTING BAR

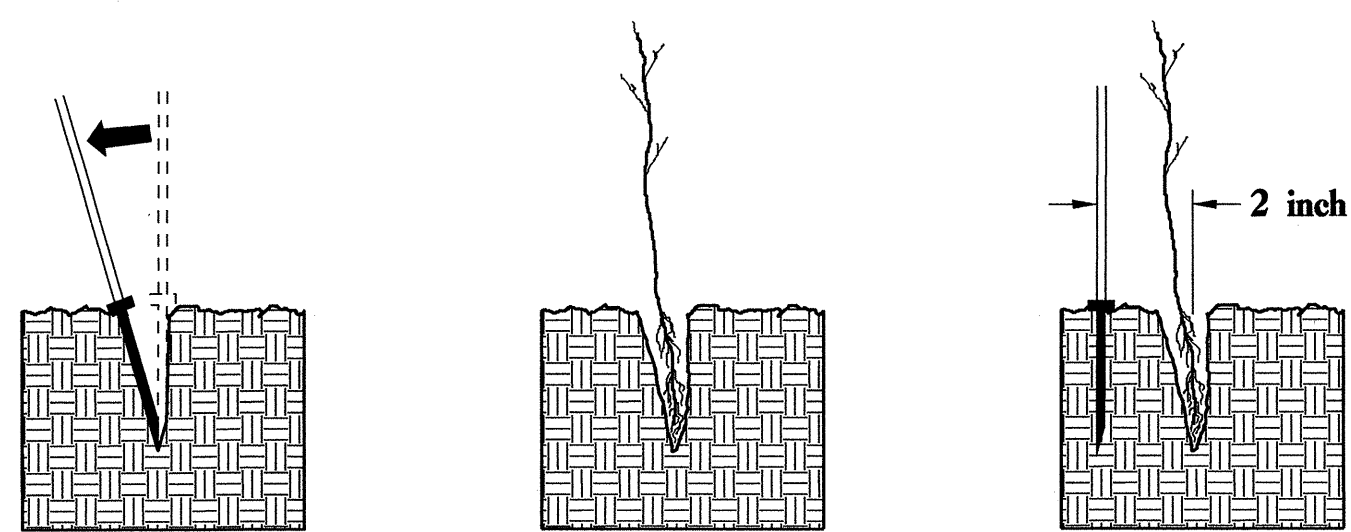

1. Insert planting bar as shown and pull handle toward planter.
2. Remove planting bar and place seedling at correct depth.
3. Insert planting bar 2 inches toward planter from seedling.

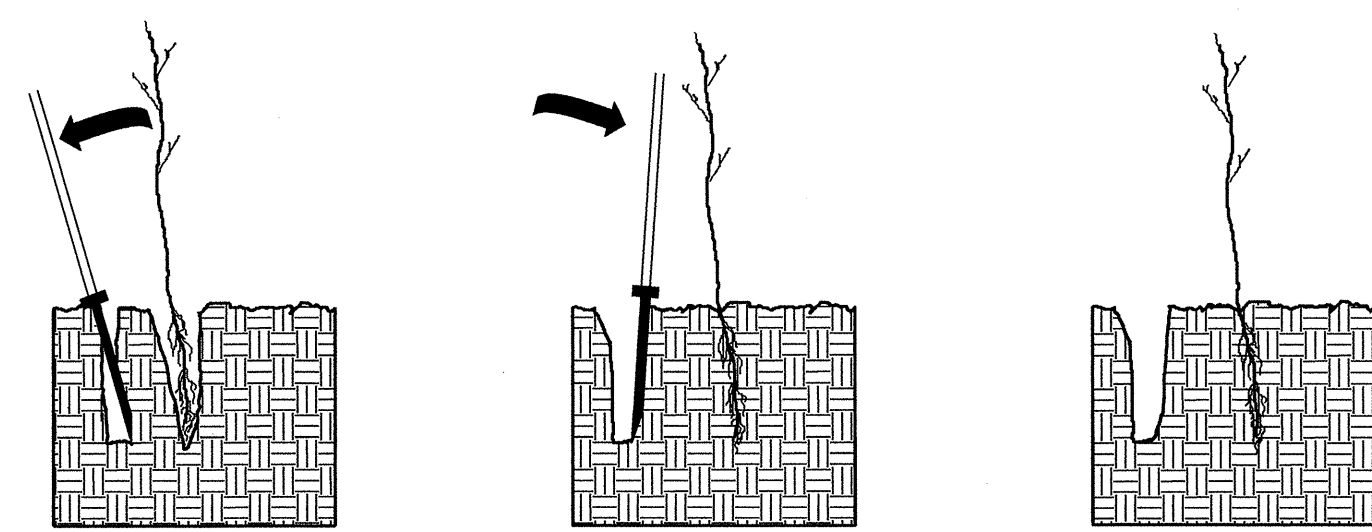

4. Pull handle of bar toward planter, firming soil at bottom.
5. Push handle forward firming soil at top.
6. Leave compaction hole open. Water thoroughly.

#### PLANTING NOTES:

**PLANTING BAG**  
During planting, seedlings shall be kept in a moist canvas bag or similar container to prevent the root systems from drying.



**KBC PLANTING BAR**  
Planting bar shall have a blade with a triangular cross section, and shall be 12 inches long, 4 inches wide and 1 inch thick at center.



**ROOT PRUNING**  
All seedlings shall be root pruned, if necessary, so that no roots extend more than 10 inches below the root collar.

## REFORESTATION

- TREE REFORESTATION SHALL BE PLANTED 6 FT. TO 10 FT. ON CENTER, RANDOM SPACING, AVERAGING 8 FT. ON CENTER, APPROXIMATELY 680 PLANTS PER ACRE.

#### REFORESTATION

MIXTURE, TYPE, SIZE, AND FURNISH SHALL CONFORM TO THE FOLLOWING:

30% TAXODIUM DISTICHUM	BALD CYPRESS	12 in - 18 in BR
30% SALIX NIGRA	BLACK WILLOW	12 in - 18 in BR
40% QUERCUS NIGRA	WATER OAK	12 in - 18 in BR

## REFORESTATION DETAIL SHEET

N.C.D.O.T. - ROADSIDE ENVIRONMENTAL UNIT

STATE OF NORTH CAROLINA  
DEPARTMENT OF TRANSPORTATION

TIP NO. B-5111	SHEET NO. SIGN-1
APPROVED: <i>A. I. Alqudwah</i>	
DATE: 9-19-13	
SEAL	

**SIGNING PLAN**  
**PITT COUNTY**

LOCATION: BRIDGE NO. III OVER BRIERY CREEK ON SR 1588

T.I.P.: B-5111

CONTRACT: C203300

**SUMMARY OF QUANTITIES**

ITEM NO.		ITEM DESCRIPTION	QUANTITY	UNIT
DESC. NO.	SECT. NO.			
4158000000	907	DISPOSAL OF SIGN SYSTEM, WOOD.....	8	EA.

**GENERAL NOTES**

- IF REMOVAL OR RELOCATION OF SIGNS ON PRIVATE STREET (NON-STATE MAINTAINED) IS REQUIRED DUE TO CONSTRUCTION, THE CONTRACTOR SHALL INFORM THE ENGINEER. THE WORK WILL BE COMPLETED BY OTHERS.
- SIGNING PLANS DO NOT INCLUDE TEMPORARY CONSTRUCTION SIGNING OR PAVEMENT MARKINGS. SEE TRAFFIC CONTROL PLANS.
- ALL EXISTING SIGNS ON "U" CHANNEL POST WITHIN THE PROJECT LIMITS SHALL BE REMOVED AND DISPOSED OF UNLESS OTHERWISE NOTED ON PLANS.
- SEE ROADWAY PLANS FOR GUARD/GUIDE RAIL DETAILS.

**PROJECT NOTES**

- DISPOSAL OF SIGN SYSTEM, WOOD

**INDEX**

SHEET NO.	DESCRIPTION
SIGN-1	TITLE SHEET, QUANTITIES, AND NOTES
SIGN-2	EXISTING SIGNS DETAIL SHEET

PLAN PREPARED BY: N.C.D.O.T. SIGNING AND DELINEATION UNIT

**A. I. ALQUDWAH, P.E.** SIGNING & DELINEATION REGIONAL ENGINEER

**D. M. EATON** SIGNING & DELINEATION PROJECT DESIGN ENGINEER

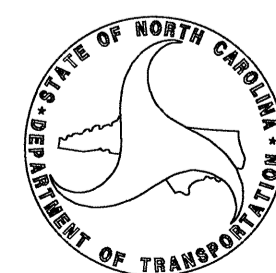

TIP NO. B-5111	SHEET NO. SIGN-2
APPROVED: <i>[Signature]</i>	
DATE: 9-19-13	
SEAL	
	

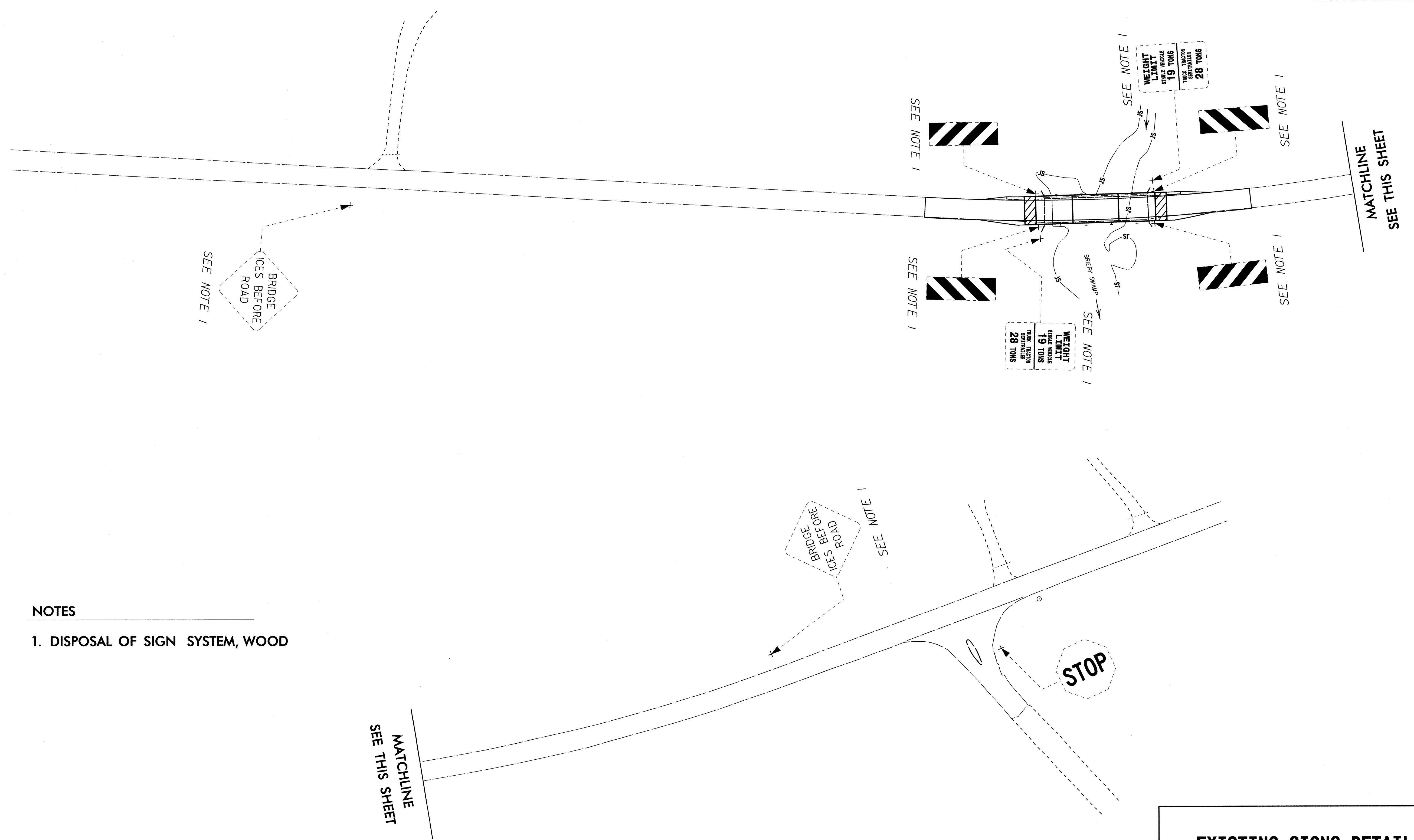
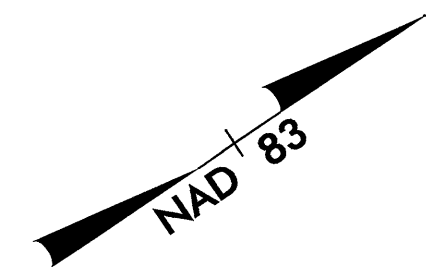

**NOTES**

1. DISPOSAL OF SIGN SYSTEM, WOOD

**EXISTING SIGNS DETAIL SHEET**

19-SEP-2013 08:00  
 P:\IT\Projects\B-5111\Traffic\Signing\CADD\Signing Layout Plans\B5111\_Sgn-tah.dgn  
 meston -A1 12/27/12



T.I.P. NO.	SHEET NO.
B-5111	UC-1

STATE OF NORTH CAROLINA  
DIVISION OF HIGHWAYS

**UTILITY CONSTRUCTION PLANS  
PITT COUNTY**

**LOCATION: BRIDGE 111 ON SR 1588 (BRIERY SWAMP RD.)  
OVER BRIERY CREEK**  
**TYPE OF WORK: RELOCATION OF WATER LINE**

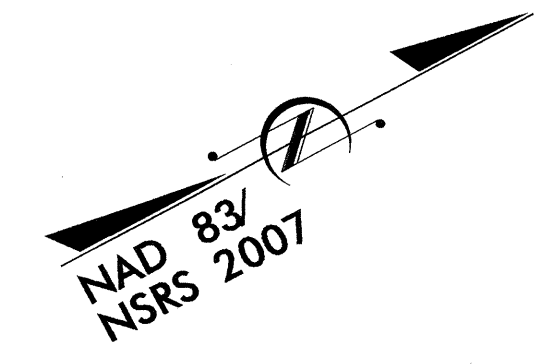
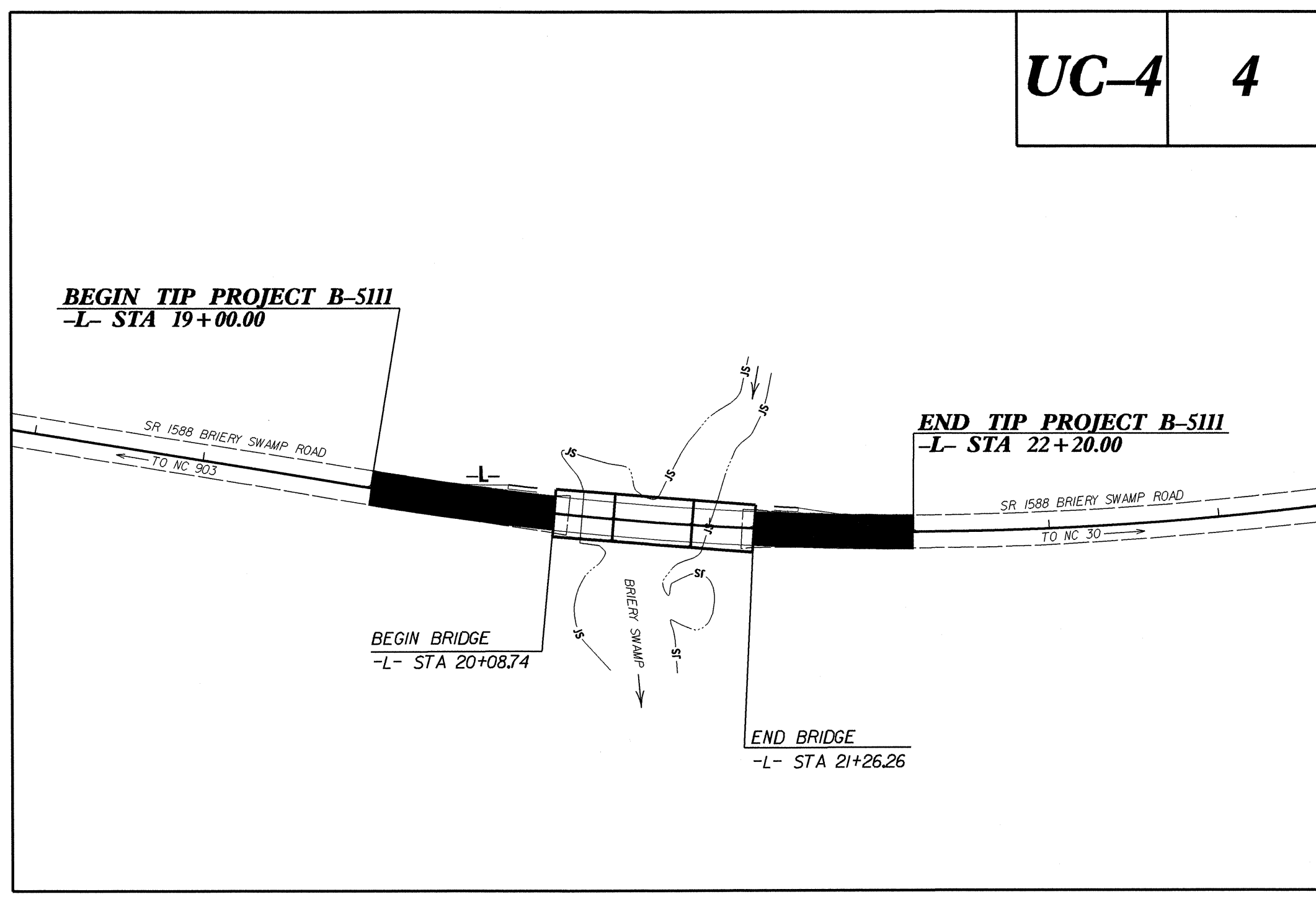
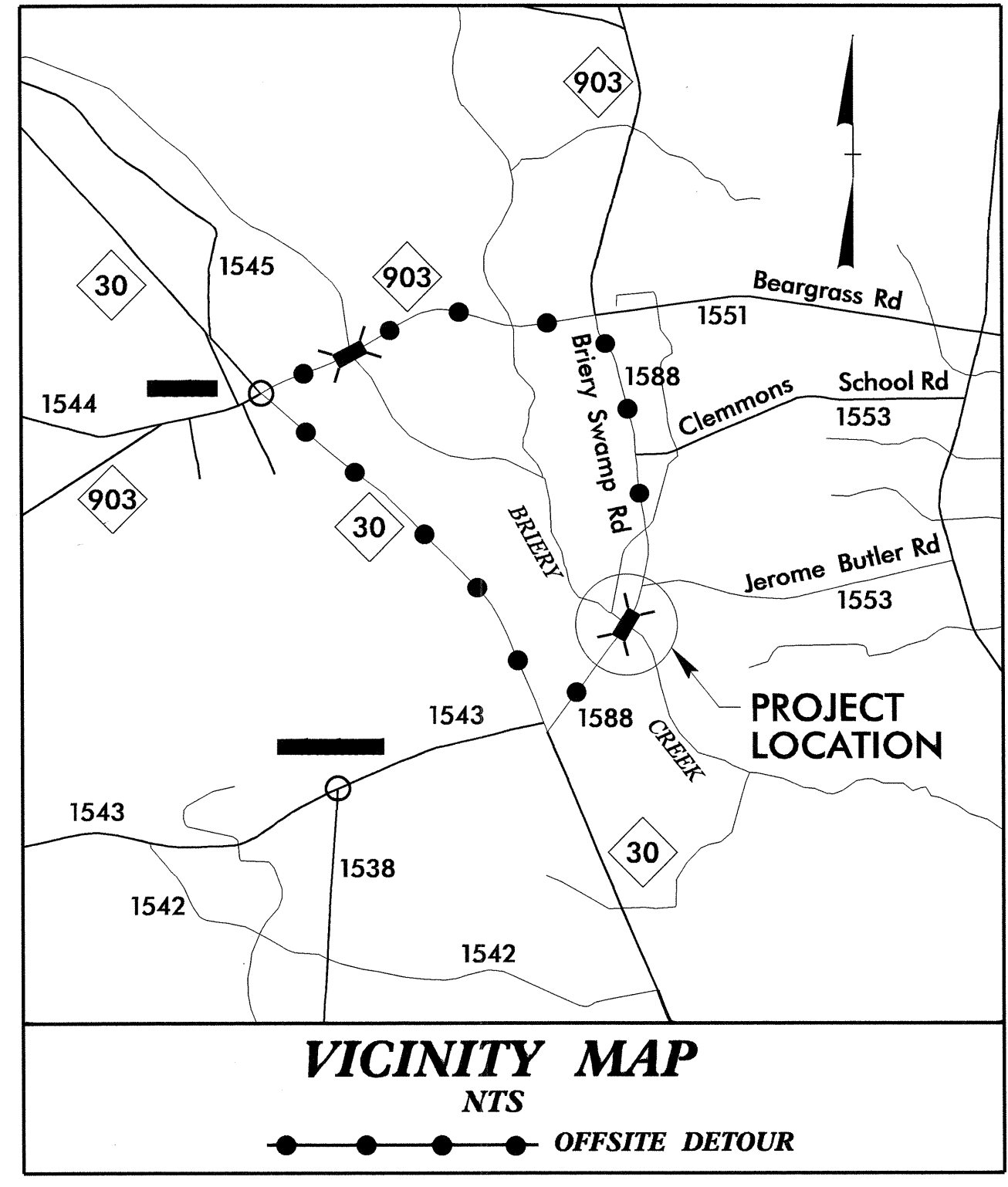

**TIP PROJECT: B-5111**

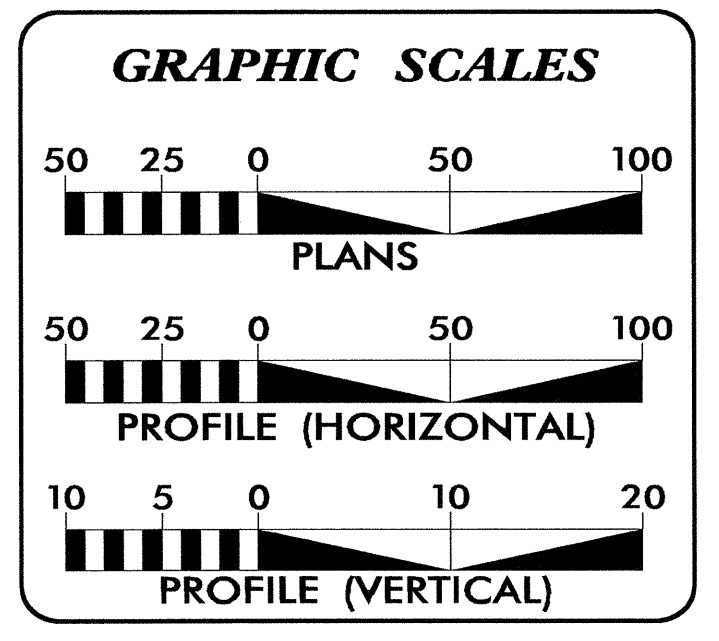

SHEET NO.	DESCRIPTION
UC-1	TITLE SHEET
UC-2	UTILITY SYMBOLOGY
UC-3	NOTES
UC-3A	DETAILS
UC-4	UTILITY CONSTRUCTION SHEET
UC-5, UC-6	PROFILE SHEETS

**WATER AND SEWER OWNERS ON PROJECT**

(1) STOKES REGIONAL WATER CORPORATION

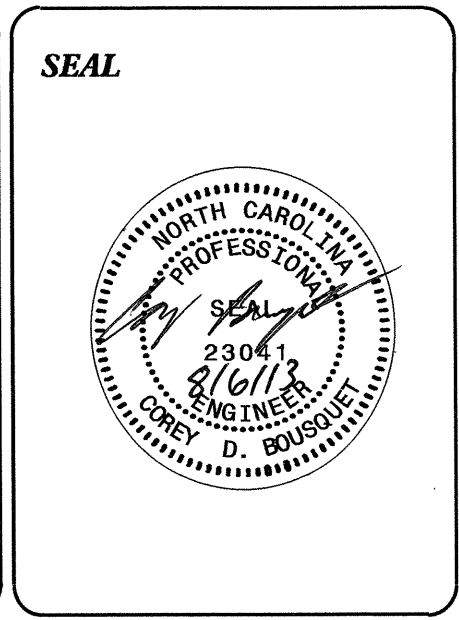

PREPARED IN THE OFFICE OF:  
**DIVISION OF HIGHWAYS  
UTILITIES UNIT  
UTILITIES ENGINEERING**

1555 MAIL SERVICES CENTER  
RALEIGH NC 27699-1555  
PHONE (919) 707-6690  
FAX (919) 250-4151

**Roger Worthington, P.E.** UTILITIES SECTION ENGINEER  
**Corey Bousquet, P.E.** UTILITIES SQUAD LEADER PROJECT ENGINEER  
**Kelvin Martin E.I.** UTILITIES PROJECT DESIGNER

STATE OF NORTH CAROLINA  
DIVISION OF HIGHWAYS

# UTILITIES PLAN SHEET SYMBOLS

## PROPOSED WATER SYMBOLS

Water Line (Sized as Shown)	----- 12" WL -----
11¼ Degree Bend	----- + + -----
22½ Degree Bend	----- + X -----
45 Degree Bend	----- + X -----
90 Degree Bend	----- + -----
Plug	-----   -----
Tee	----- + + -----
Cross	----- + + -----
Reducer	----- ▶ -----
Gate Valve	----- GV -----
Butterfly Valve	----- BV -----
Tapping Valve	----- TGV -----
Line Stop	----- LS -----
Line Stop with Bypass	----- LS/BP -----
Blow Off	----- BO -----
Fire Hydrant	----- FHH -----
Relocate Fire Hydrant	----- REH -----
Remove Fire Hydrant	----- REM FH -----
Water Meter	----- WM -----
Relocate Water Meter	----- RWM -----
Remove Water Meter	----- REM WM -----
Water Pump Station	----- PS(W) -----
RPZ Backflow Preventer	----- PRPZ -----
DCV Backflow Preventer	----- PBCP -----
Relocate RPZ Backflow Preventer	----- RRPZ -----
Relocate DCV Backflow Preventer	----- RBCP -----

## PROPOSED SEWER SYMBOLS

Gravity Sewer Line (Sized as Shown)	----- 12" GS -----
Force Main Sewer Line (Sized as Shown)	----- 12" FSS -----
Manhole (Sized per Note)	----- • -----
Sewer Pump Station	----- PS(SS) -----

## PROPOSED MISCELLANEOUS UTILITIES SYMBOLS

Power Pole	----- ○ -----
Telephone Pole	----- -○- -----
Joint Use Pole	----- -○- -----
Telephone Pedestal	----- TEL PED -----
Utility Line by Others (Type as Shown)	----- PROP O/H POW LINES -----
Trenchless Installation	----- 12" TL INSTALL -----
Encasement by Open Cut	----- 24" ENCAS BY OC -----
Encasement	----- 24" ENCASEMENT -----

Thrust Block	-----   -----
Air Release Valve	----- AR -----
Utility Vault	----- UV -----
Concrete Pier	----- CP -----
Steel Pier	----- SP -----
Plan Note	----- ↖ -----
Pay Item Note	----- ↖ -----

NOTE  
PAY ITEM

## EXISTING UTILITIES SYMBOLS

Power Pole	----- • -----	*Underground Power Line	----- P -----
Telephone Pole	----- • -----	*Underground Telephone Cable	----- T -----
Joint Use Pole	----- • -----	*Underground Telephone Conduit	----- TC -----
Utility Pole	----- • -----	*Underground Fiber Optics Telephone Cable	----- T FO -----
Utility Pole with Base	----- □ -----	*Underground TV Cable	----- TV -----
H-Frame Pole	----- •-----	*Underground Fiber Optics TV Cable	----- TV FO -----
Power Transmission Line Tower	----- ⊠ -----	*Underground Gas Pipeline	----- G -----
Water Manhole	----- ⊙ -----	Aboveground Gas Pipeline	----- A/G Gas -----
Power Manhole	----- ⊙ -----	*Underground Water Line	----- W -----
Telephone Manhole	----- ⊙ -----	Aboveground Water Line	----- A/G Water -----
Sanitary Sewer Manhole	----- ⊙ -----	*Underground Gravity Sanitary Sewer Line	----- SS -----
Hand Hole for Cable	----- ⊠ -----	Aboveground Gravity Sanitary Sewer Line	----- A/G Sanitary Sewer -----
Power Transformer	----- ⊠ -----	*Underground SS Forced Main Line	----- FSS -----
Telephone Pedestal	----- ⊠ -----	Underground Unknown Utility Line	----- ?UTL -----
CATV Pedestal	----- ⊠ -----	SUE Test Hole	----- • -----
Gas Valve	----- ◇ -----	Water Meter	----- ○ -----
Gas Meter	----- ◇ -----	Water Valve	----- ⊙ -----
Located Miscellaneous Utility Object	----- ○ -----	Fire Hydrant	----- ◇ -----
Abandoned According to Utility Records	----- AATUR -----	Sanitary Sewer Cleanout	----- ⊙ -----
End of Information	----- E.O.I. -----		

\*For Existing Utilities  
Utility Line Drawn from Record (Type as Shown) -----  
Designated Utility Line (Type as Shown) -----

PROJECT REFERENCE NO.	SHEET NO.
B-5111	UC-3
DESIGNED BY: KSM	
DRAWN BY: KSM	
CHECKED BY: CDB	
APPROVED BY: CDB	
REVISED:	
NORTH CAROLINA DEPARTMENT OF TRANSPORTATION	
UTILITIES ENGINEERING SEC. PHONE: (919) 707-6690 FAX: (919) 250-4151	
UTILITY CONSTRUCTION PLANS ONLY	

# UTILITY CONSTRUCTION

## GENERAL NOTES:

1. THE PROPOSED UTILITY CONSTRUCTION SHALL MEET THE APPLICABLE REQUIREMENTS OF THE NC DEPARTMENT OF TRANSPORTATION'S "STANDARD SPECIFICATIONS FOR ROADS AND STRUCTURES" DATED JANUARY 2012.
2. THE EXISTING UTILITIES BELONG TO STOKES REGIONAL WATER CORPORATION .
3. ALL WATER LINES TO BE INSTALLED WITHIN COMPLIANCE OF THE RULES AND REGULATIONS OF THE NORTH CAROLINA DEPARTMENT OF ENVIRONMENTAL AND NATURAL RESOURCES, DIVISION OF WATER RESOURCES, PUBLIC WATER SUPPLY SECTION. ALL SEWER LINES TO BE INSTALLED WITHIN COMPLIANCE OF THE RULES AND REGULATIONS OF THE NORTH CAROLINA DEPARTMENT OF ENVIRONMENT AND NATURAL RESOURCES, DIVISION OF WATER RESOURCES, WATER QUALITY SECTION. PERFORM ALL WORK IN ACCORDANCE WITH THE APPLICABLE PLUMBING CODES.
4. THE UTILITY OWNER OWNS THE EXISTING UTILITY FACILITIES AND WILL OWN THE NEW UTILITY FACILITIES AFTER ACCEPTANCE BY THE DEPARTMENT. THE DEPARTMENT OWNS THE CONSTRUCTION CONTRACT AND HAS ADMINISTRATIVE AUTHORITY. COMMUNICATIONS AND DECISIONS BETWEEN THE CONTRACTOR AND UTILITY OWNER ARE NOT BINDING UPON THE DEPARTMENT OR THIS CONTRACT UNLESS AUTHORIZED BY THE ENGINEER. AGREEMENTS BETWEEN THE UTILITY OWNER AND CONTRACTOR FOR THE WORK THAT IS NOT PART OF THIS CONTRACT OR IS SECONDARY TO THIS CONTRACT ARE ALLOWED, BUT ARE NOT BINDING UPON THE DEPARTMENT.
5. PROVIDE ACCESS FOR THE DEPARTMENT PERSONNEL AND THE OWNER'S REPRESENTATIVES TO ALL PHASES OF CONSTRUCTION. NOTIFY DEPARTMENT PERSONNEL AND THE UTILITY OWNER TWO WEEKS PRIOR TO COMMENCEMENT OF ANY WORK AND ONE WEEK PRIOR TO SERVICE INTERRUPTION. KEEP UTILITY OWNERS' REPRESENTATIVES INFORMED OF WORK PROGRESS AND PROVIDE OPPROTUNITY FOR INSPECTION OF CONSTRUCTION AND TESTING.

6. THE PLANS DEPICT THE BEST AVAILABLE INFORMATION FOR THE LOCATION, SIZE, AND TYPE OF MATERIAL FOR ALL EXISTING UTILITIES. MAKE INVESTIGATIONS FOR DETERMINING THE EXACT LOCATION, SIZE, AND TYPE MATERIAL OF THE EXISTING FACILITIES AS NECESSARY FOR THE CONSTRUCTION OF THE PROPOSED UTILITIES AND FOR AVOIDING DAMAGE TO EXISTING FACILITIES. REPAIR ANY DAMAGE INCURRED TO EXISTING FACILITIES TO THE ORIGINAL OR BETTER CONDITION AT NO ADDITIONAL COST TO THE DEPARTMENT.

7. MAKE FINAL CONNECTIONS OF THE NEW WORK TO THE EXISTING SYSTEM WHERE INDICATED ON THE PLANS, AS REQUIRED TO FIT THE ACTUAL CONDITIONS, OR AS DIRECTED.

8. MAKE CONNECTIONS BETWEEN EXISTING AND PROPOSED UTILITIES AT TIMES MOST CONVENIENT TO THE PUBLIC, WITHOUT ENDANGERING THE UTILITY SERVICE, AND IN ACCORDANCE WITH THE UTILITY OWNER'S REQUIREMENTS. MAKE CONNECTIONS ON WEEKENDS, AT NIGHT, AND ON HOLIDAYS IF NECESSARY.

9. ALL UTILITY MATERIALS SHALL BE APPROVED PRIOR TO DELIVERY TO THE PROJECT. SEE 1500-7, " SUBMITTALS AND RECORDS" IN SECTION 1500 OF THE STANDARD SPECIFICATIONS.

## PROJECT SPECIFIC NOTES:

1. CONTRACTOR'S ATTENTION IS DIRECTED TO SECTIONS 102, 107, AND 1550 OF THE STANDARD SPECIFICATIONS CONCERNING TRENCHLESS INSTALLATION. IT IS CONTRACTOR'S RESPONSIBILITY TO HAVE BORE PATH DESIGNED AND SEALED BY A LICENSED NORTH CAROLINA PROFESSIONAL ENGINEER. NO DAMAGE IS ALLOWED TO RIVER, WETLANDS, OR BUFFER ZONES.
2. IF HDPE PIPE IS INSTALLED BY DIRECTIONAL DRILL. IT SHALL BE FILLED WITH WATER AND NOT BE CONNECTED TO ANY OTHER PIPE OR FITTINGS FOR ONE WEEK FROM THE TIME OF INSTALLATION.

## UTILITY CONSTRUCTION

# PROJECT TYPICAL DETAILS

## UTILITY CONSTRUCTION

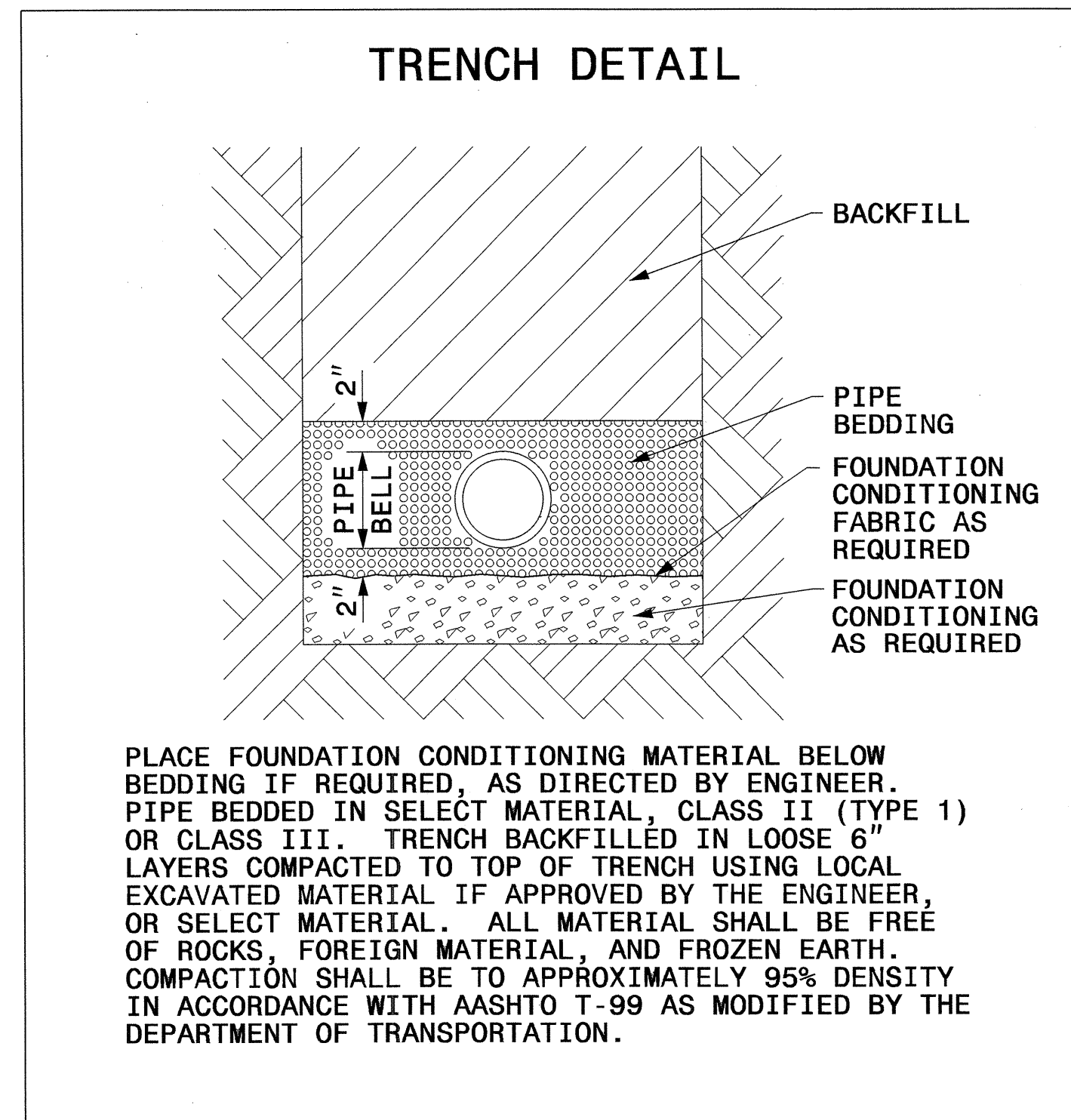

MAXIMUM TRENCH WIDTH AT TOP OF PIPE			
NOMINAL PIPE SIZE (INCHES)	TRENCH WIDTH (INCHES)	NOMINAL PIPE SIZE (INCHES)	TRENCH WIDTH (INCHES)
4	28	20	44
6	30	24	48
8	32	30	54
10	34	36	60
12	36	42	66
14	38	48	72
16	40	54	78
18	42		

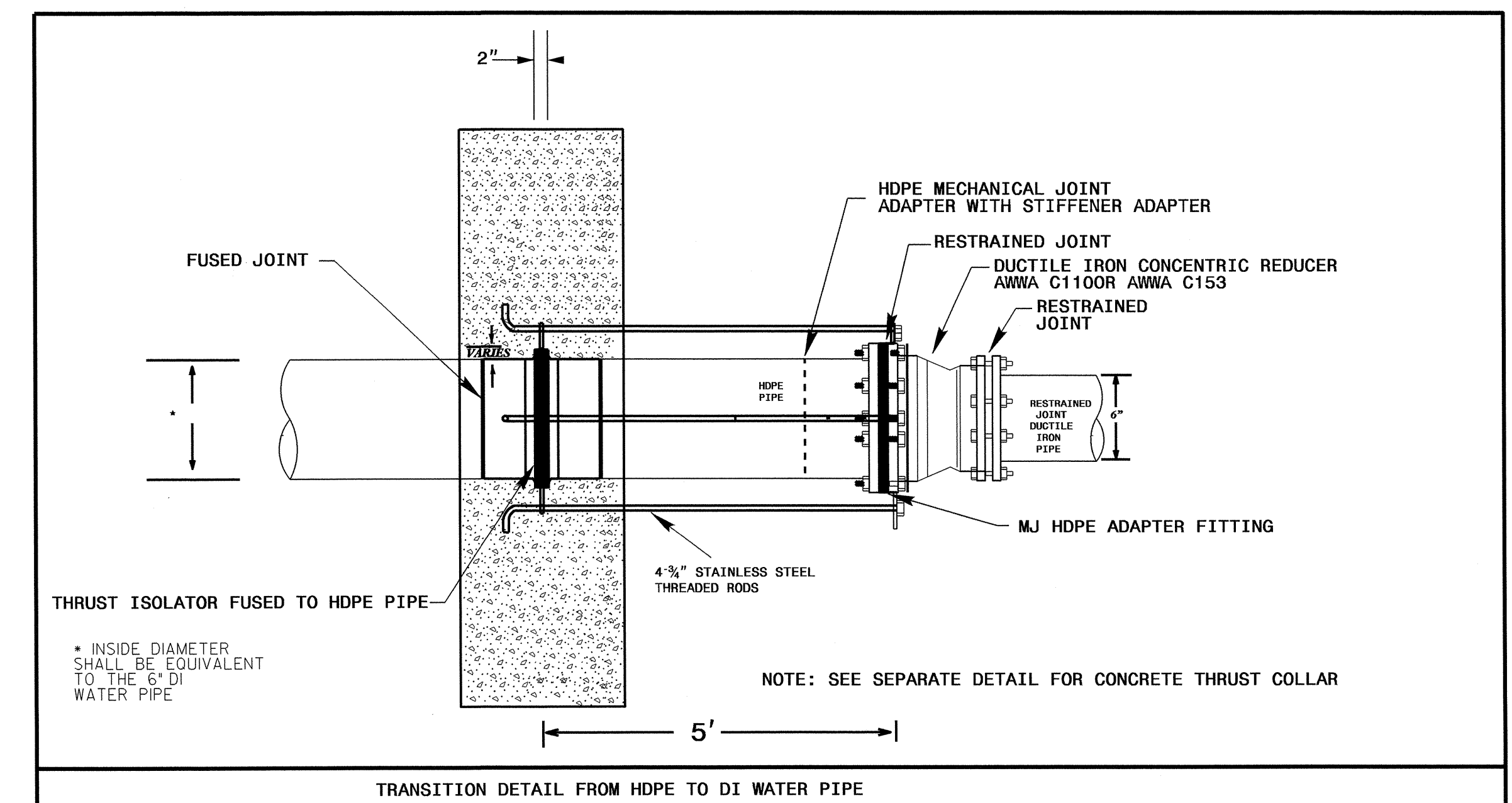
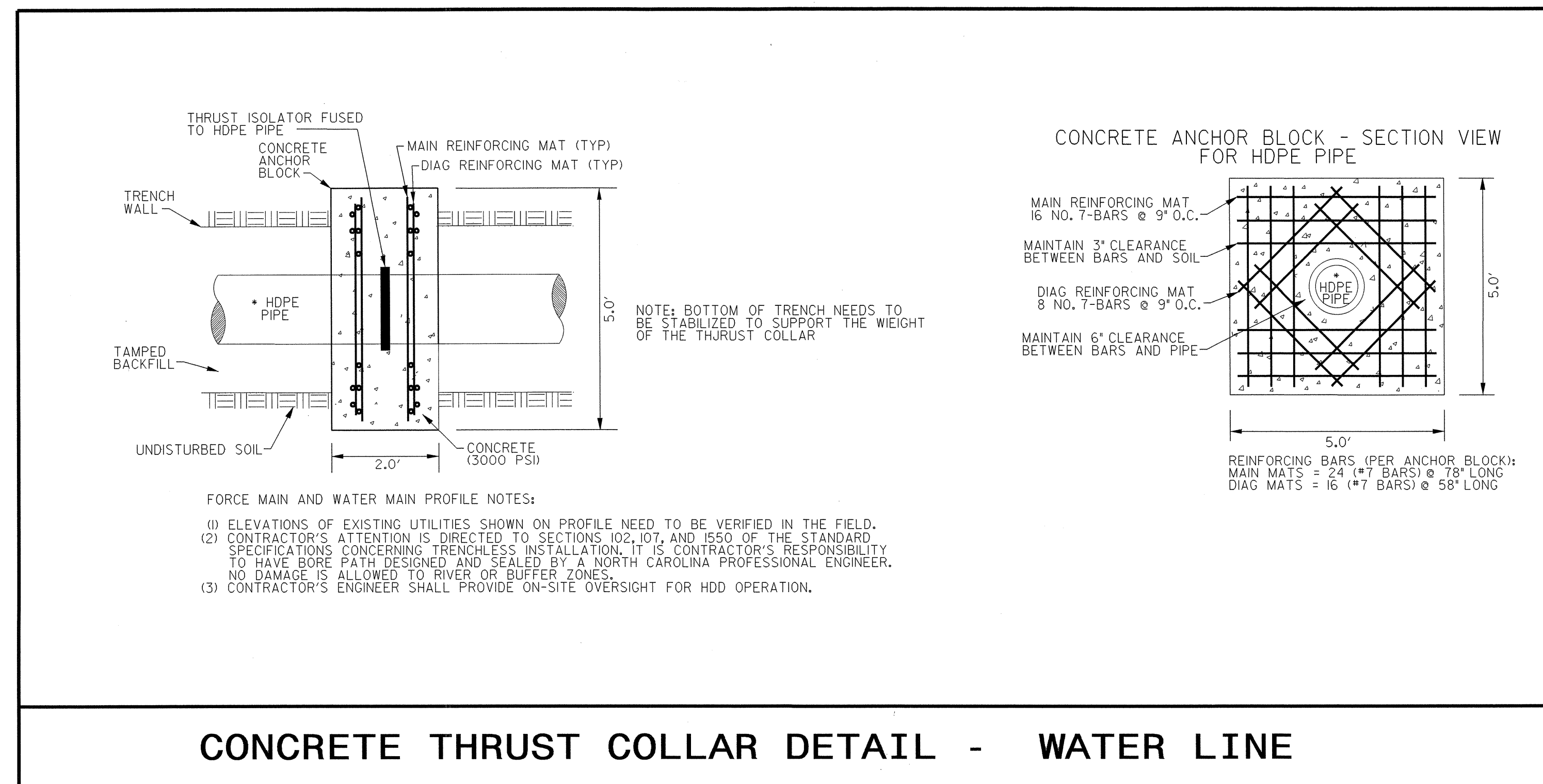

5/14/99

07-AUG-2013 07:49  
 I:\projects\B-5111-ut-dtl\UC3a.psh.dgn

PROJECT REFERENCE NO.	SHEET NO.
<b>B-5111</b>	<b>UC-4</b>
DESIGNED BY: <b>KSM</b>	
DRAWN BY: <b>KSM</b>	
CHECKED BY: <b>CDB</b>	
APPROVED BY: <b>CDB</b>	
REVISED:	
NORTH CAROLINA DEPARTMENT OF TRANSPORTATION UTILITIES ENGINEERING SEC. PHONE: (919) 707-6690 FAX: (919) 250-4151	
UTILITY CONSTRUCTION PLANS ONLY	

**UTILITY CONSTRUCTION**

IF HDPE WATER PIPE IS USED FOR THE TRENCHLESS INSTALLATION, USE 8" HDPE WATER PIPE TO MATCH THE INSIDE DIAMETER OF 6" DI WATER PIPE.

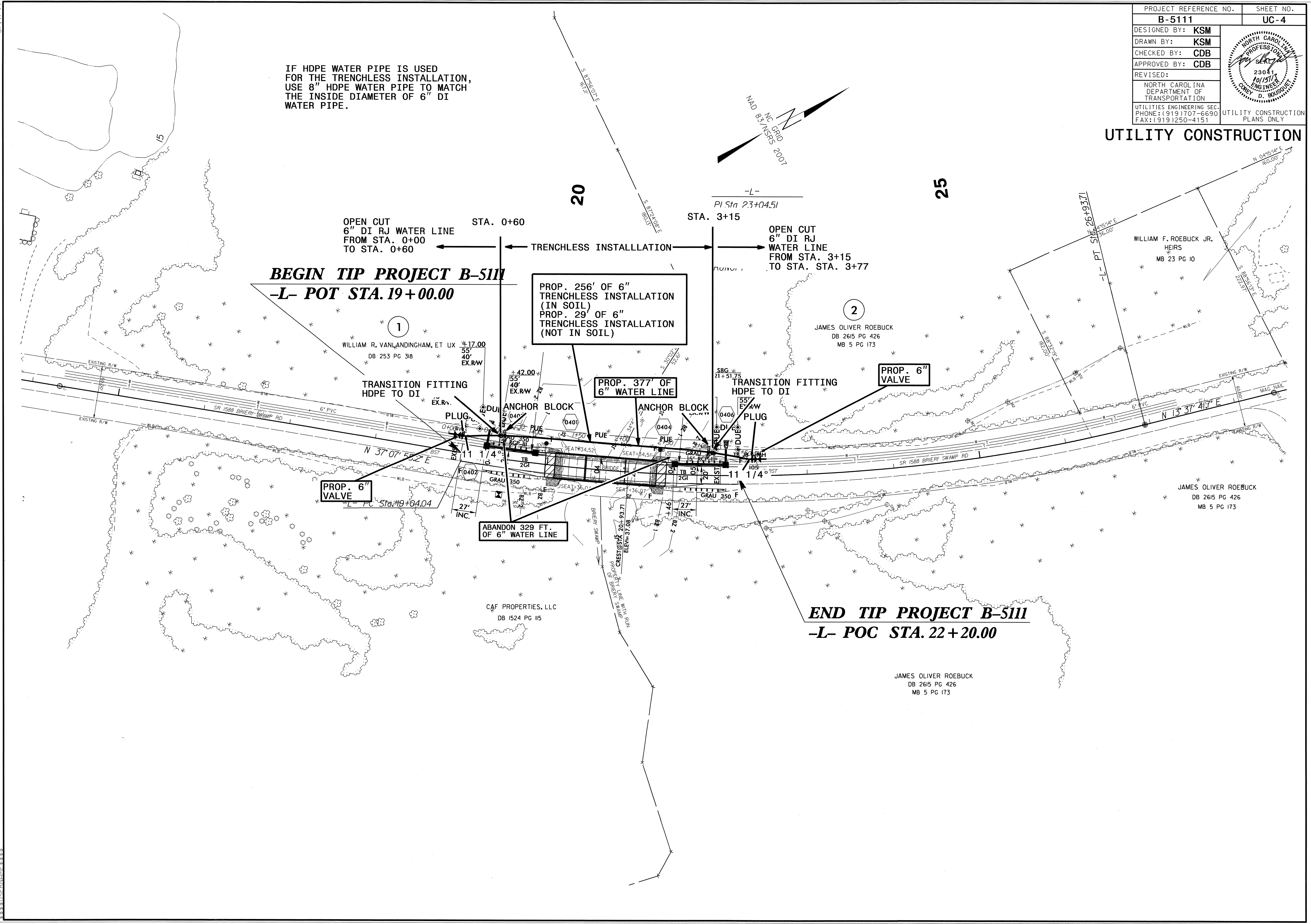
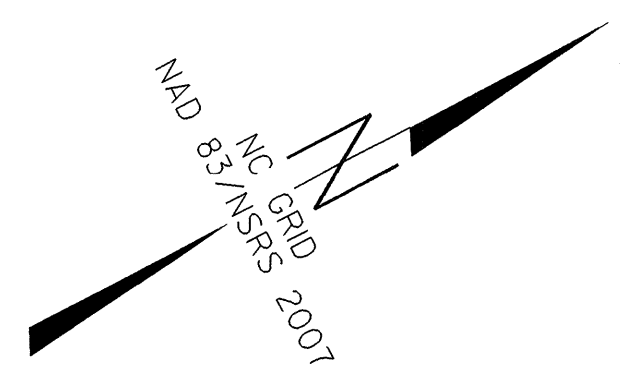

**BEGIN TIP PROJECT B-5111**  
**-L- POT STA. 19+00.00**

PROP. 256' OF 6" TRENCHLESS INSTALLATION (IN SOIL)  
 PROP. 29' OF 6" TRENCHLESS INSTALLATION (NOT IN SOIL)

2  
 JAMES OLIVER ROEBUCK  
 DB 2615 PG 426  
 MB 5 PG 173

PROP. 6" VALVE

ABANDON 329 FT. OF 6" WATER LINE

PROP. 6" VALVE

**END TIP PROJECT B-5111**  
**-L- POC STA. 22+20.00**

JAMES OLIVER ROEBUCK  
 DB 2615 PG 426  
 MB 5 PG 173

5/14/99

15-OCT-2013 07:55  
 ps:\Engineering\UC\Projects\UCSheets\B-5111-ut-rd\4\_UC4\_psh.dgn

5/14/99

06-AUG-2013 11:41 AM  
R:\Utilities\Projects\UC\Sheets\6 INCH LINE1.dgn

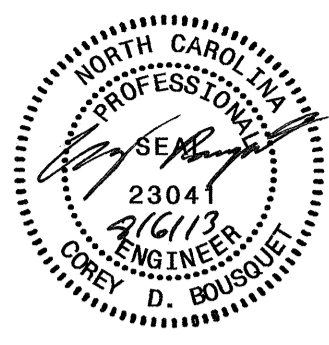
PROJECT REFERENCE NO.	B-5111	SHEET NO.	UC-5
DESIGNED BY:	KSM		
DRAWN BY:	KSM		
CHECKED BY:	CDB		
APPROVED BY:	CDB		
REVISED:		NORTH CAROLINA DEPARTMENT OF TRANSPORTATION UTILITIES ENGINEERING SEC. PHONE: (919) 707-6690 FAX: (919) 250-4151	
UTILITY CONSTRUCTION			PLANS ONLY

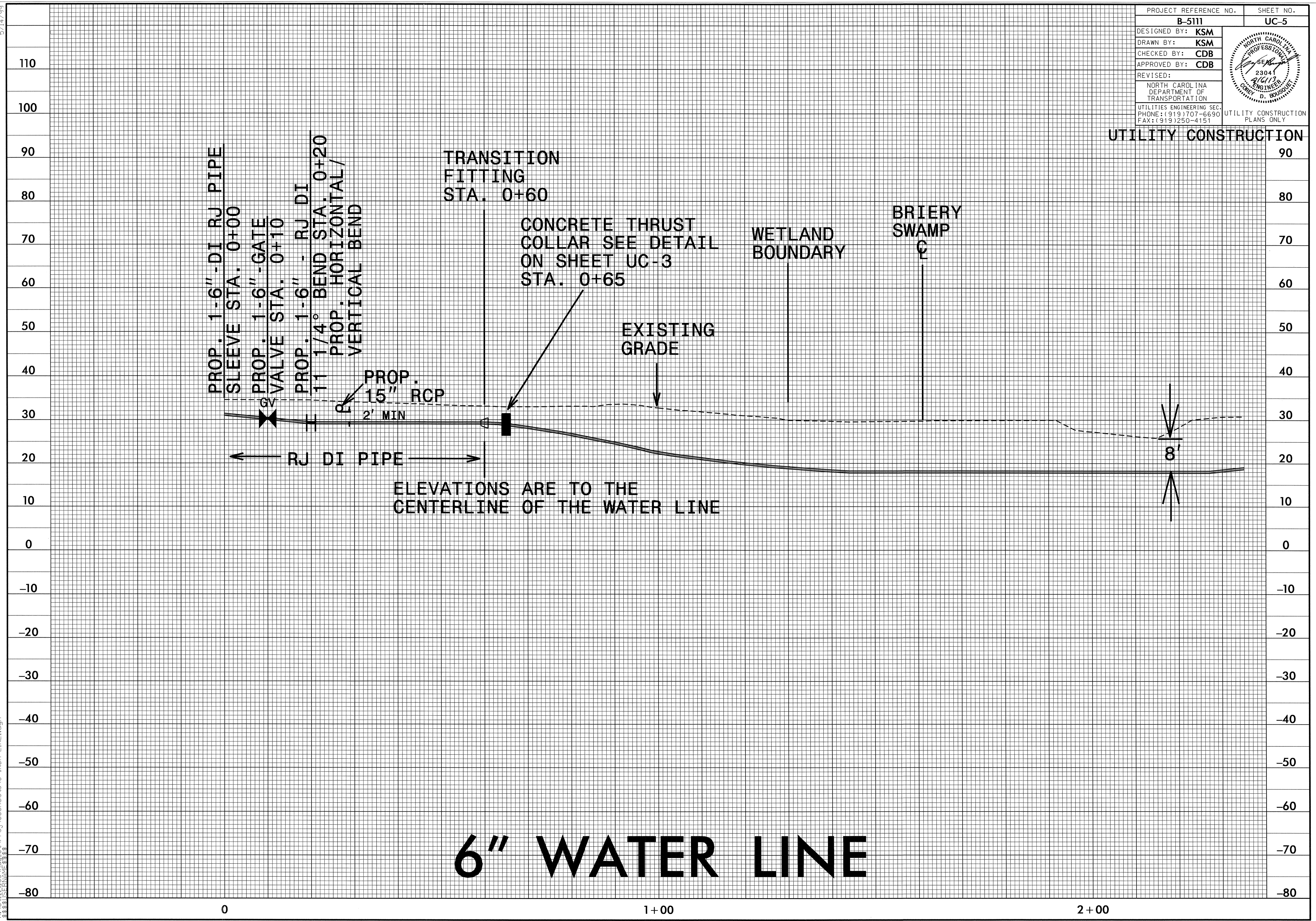

ELEVATIONS ARE TO THE CENTERLINE OF THE WATER LINE

# 6" WATER LINE

PROP. 1-6" -DI RJ PIPE  
 SLEEVE STA. 0+00  
 PROP. 1-6" -GATE  
 VALVE STA. 0+10  
 PROP. 1-6" - RJ DI  
 1 1/4° BEND STA. 0+20  
 PROP. HORIZONTAL/  
 VERTICAL BEND

TRANSITION  
 FITTING  
 STA. 0+60

CONCRETE THRUST  
 COLLAR SEE DETAIL  
 ON SHEET UC-3  
 STA. 0+65

EXISTING GRADE

WETLAND BOUNDARY

BRIERY SWAMP

← RJ DI PIPE →

8'

0

1+00

2+00

5/14/99

06-AUG-2013 15:15 I:\A\Proj\UCSheets\6 INCH LINE1.dgn

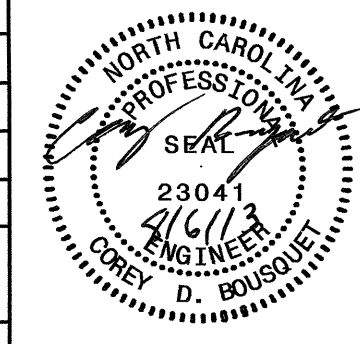
PROJECT REFERENCE NO.	SHEET NO.
B-5111	UC-6
DESIGNED BY: KSM	
DRAWN BY: KSM	
CHECKED BY: CDB	
APPROVED BY: CDB	
REVISED:	
NORTH CAROLINA DEPARTMENT OF TRANSPORTATION UTILITIES ENGINEERING SEC. PHONE: (919) 707-6690 FAX: (919) 250-4151	
UTILITY CONSTRUCTION PLANS ONLY	

### UTILITY CONSTRUCTION

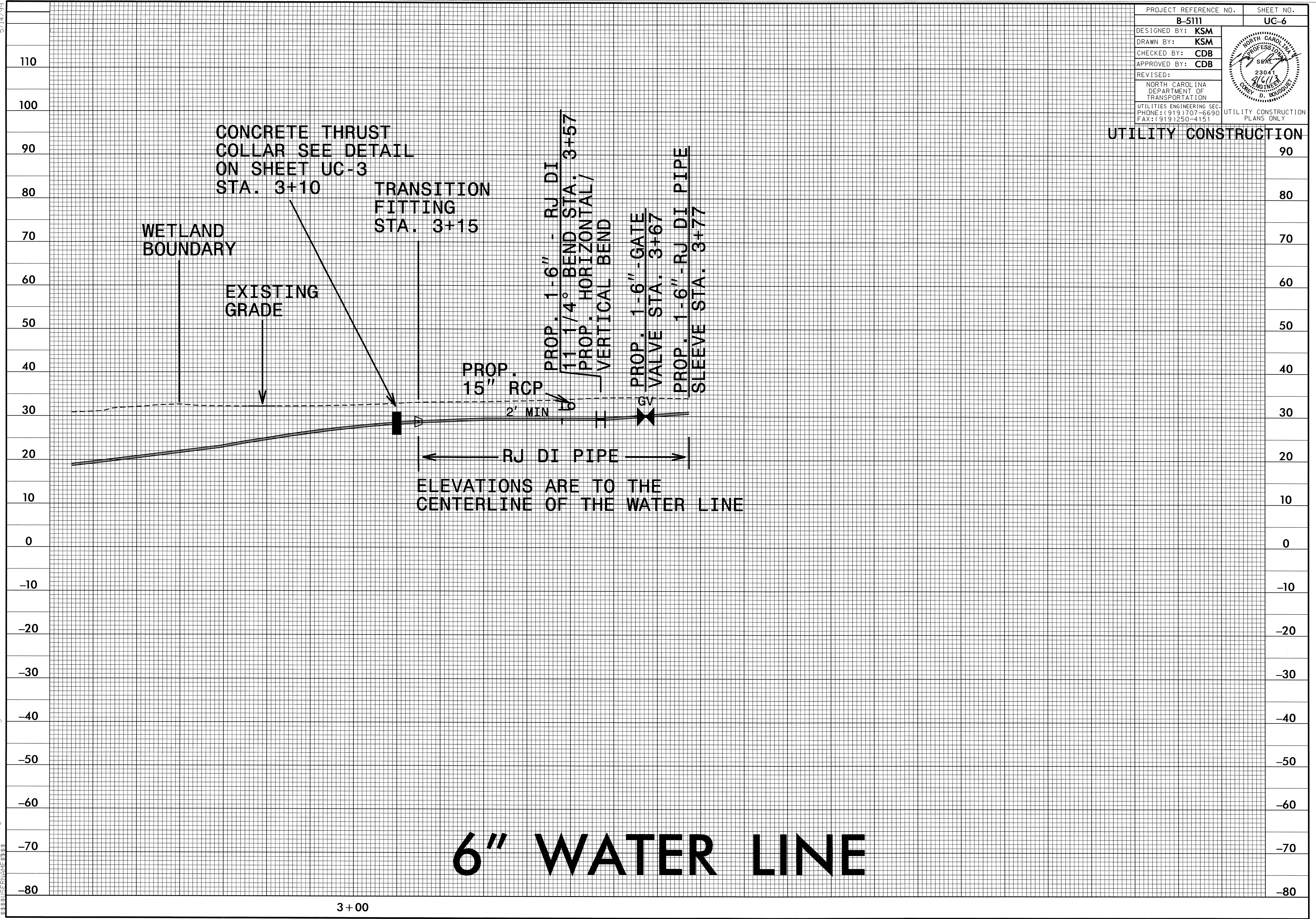

# 6" WATER LINE

3+00

09/08/99

T.I.P. NO.	SHEET NO.
B-5111	UO-1

STATE OF NORTH CAROLINA  
DIVISION OF HIGHWAYS

**UTILITIES BY OTHERS PLANS  
PITT COUNTY**

**LOCATION: BRIDGE III ON SR1588 (BRIERY SWAMP RD.)  
OVER BRIERY CREEK**

**TYPE OF WORK: RELOCATION OF TELEPHONE LINE**

**TIP PROJECT: B-5111**

**CONTRACT: C203300**

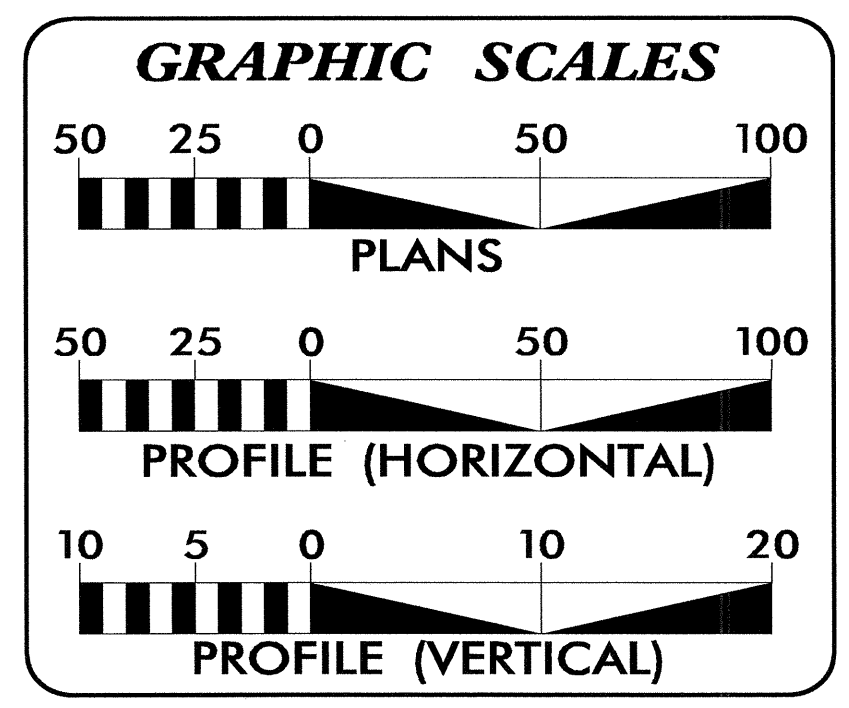
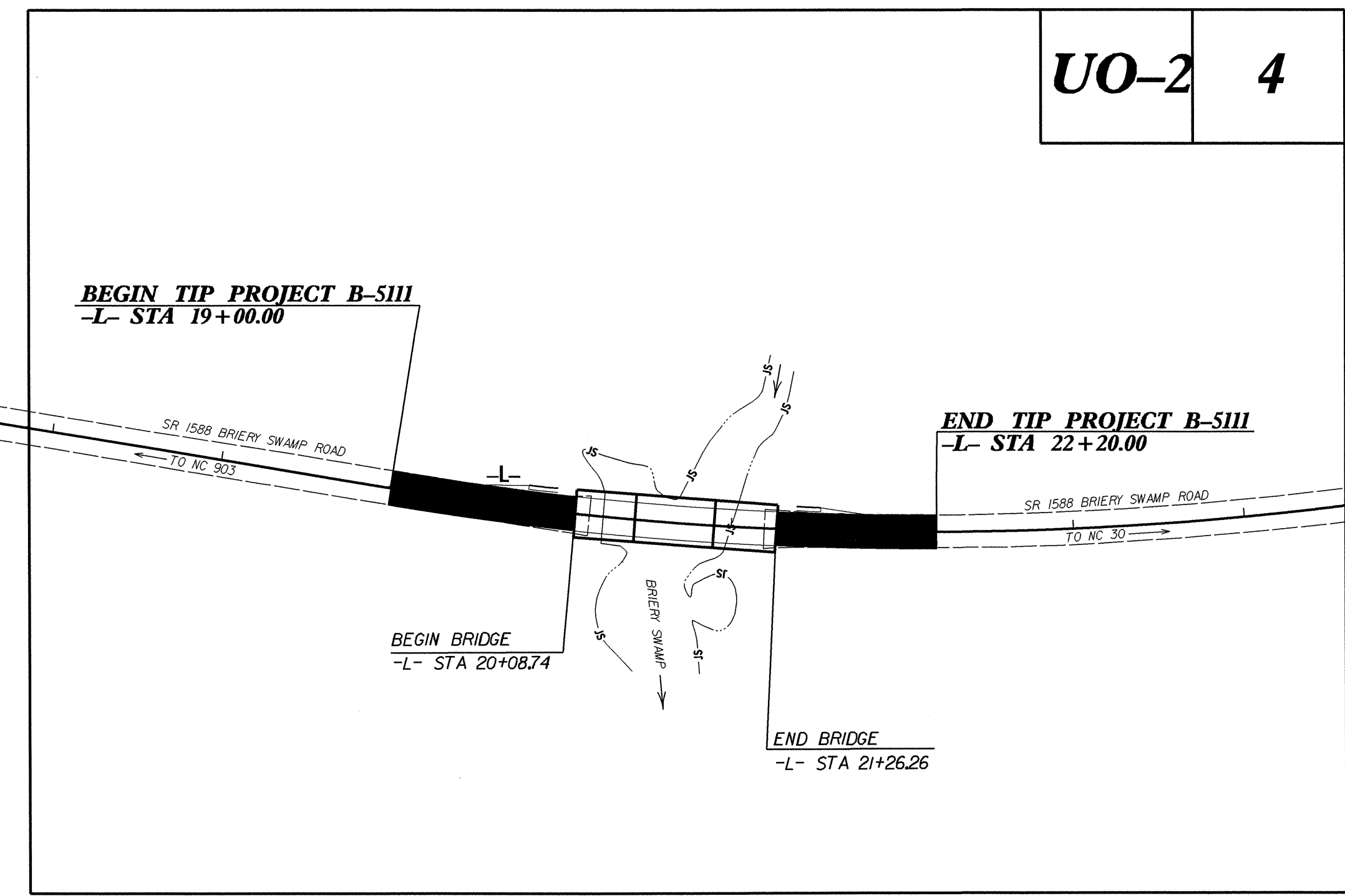
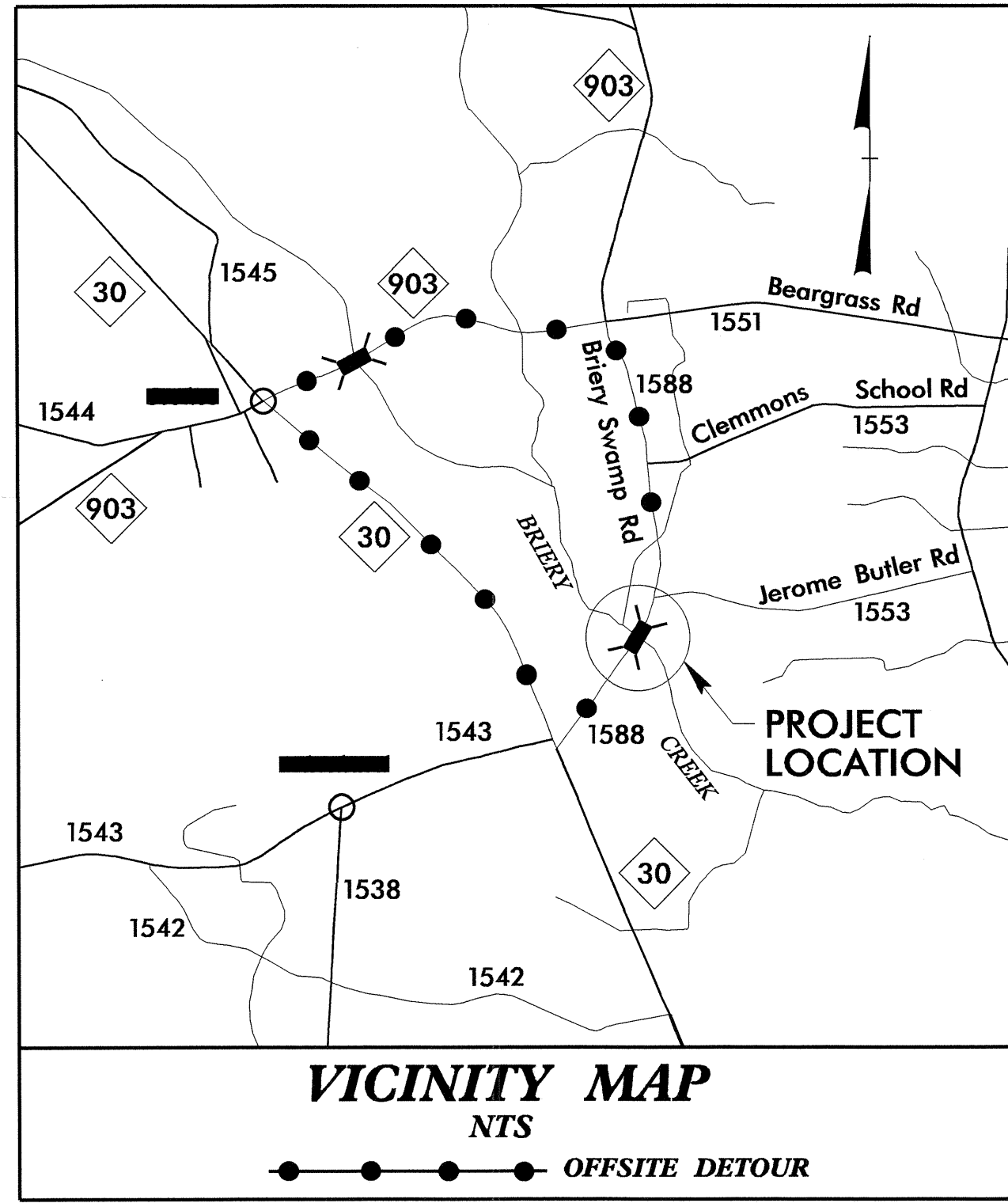

**INDEX OF SHEETS**

SHEET NO.	DESCRIPTION
UO-1	TITLE SHEET
UO-2	UTILITY BY OTHERS PLAN SHEET

**UTILITY OWNERS ON PROJECT**

(A) CENTURYLINK TELEPHONE

PREPARED IN THE OFFICE OF:  
**DIVISION OF HIGHWAYS  
UTILITIES UNIT  
UTILITIES ENGINEERING**

1555 MAIL SERVICES CENTER  
RALEIGH NC 27699-1555  
PHONE (919) 707-6690  
FAX (919) 250-4151

**Roger Worthington, P.E.** UTILITIES SECTION ENGINEER  
**Corey Bousquet, P.E.** UTILITIES SQUAD LEADER PROJECT ENGINEER  
**Kelvin Martin E.I.** UTILITIES PROJECT DESIGNER

06-AUG-2013 14:13 R:\Utilities\RDY\_UH\Proj\UB0sheets\B-5111\_ut\_tsh\_u01.psh.dgn \$\$\$USERNAME\$\$\$



### UTILITIES BY OTHERS

**NOTE:**  
ALL PROPOSED UTILITY WORK  
SHOWN ON THIS SHEET WILL  
BE DONE BY OTHERS

5/14/99

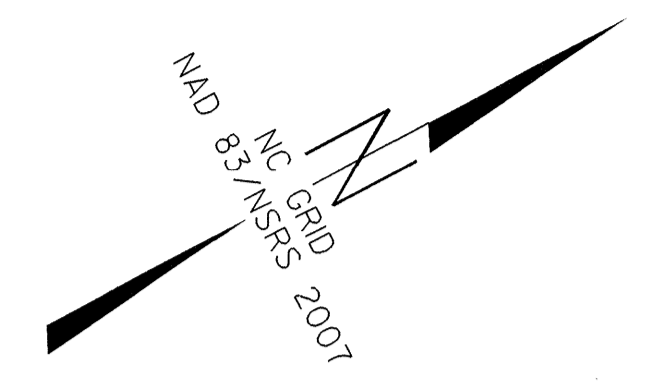

-L-  
PI Sta 23+04.51  
 $\Delta = 23^\circ 30' 13.5''$  (LT)  
 $D = 2^\circ 58' 35.1''$   
 $L = 789.67'$   
 $T = 400.47'$   
 $R = 1,925.00'$

**BEGIN TIP PROJECT B-5111**  
**-L- STA 19+00.00**

**END TIP PROJECT B-5111**  
**-L- STA 22+20.00**

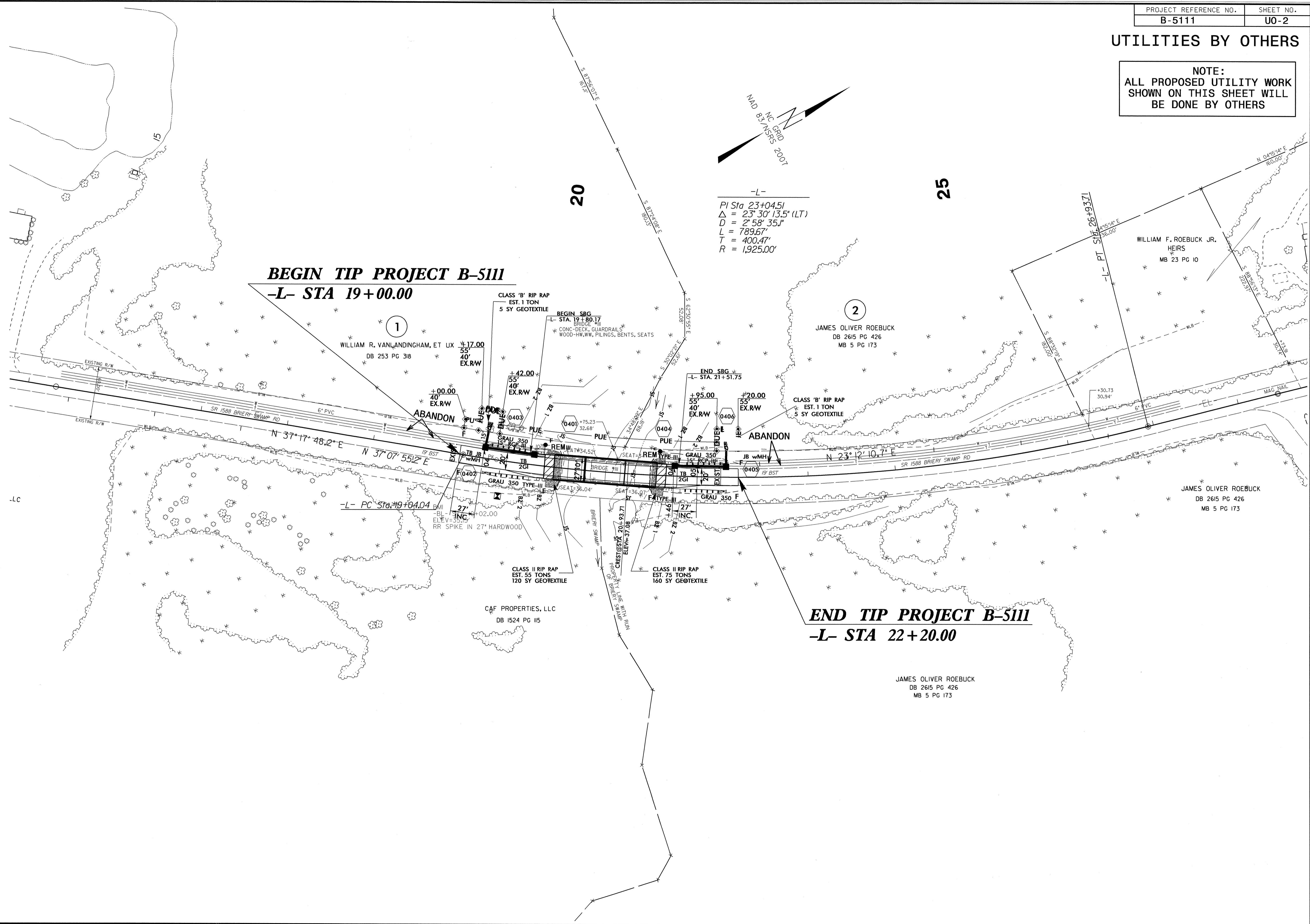

I:\projects\06-AUG-2013\1418\sheet\B-5111-Ut\_rdy4\_U02.psh.dgn  
 8/13/13 10:41:33 AM  
 1418

PROJ. REFERENCE NO.	SHEET NO.
B-5111	X-1A

**STATE OF NORTH CAROLINA  
DIVISION OF HIGHWAYS**

**Approximate quantities only. Unclassified excavation, borrow excavation, clearing and grubbing, fine grading, and removal of existing pavement will be paid for at the lump sum price for "Grading".**

**CROSS-SECTION SUMMARY**

NOTE: EMBANKMENT COLUMN DOES NOT INCLUDE BACKFILL FOR UNDERCUT

Station Before Bridge L	Uncl. Exc. (cu. yd.)	Embt (cu. yd.)
19+00.00	0	0
19+25.00	1	3
19+50.00	1	3
19+75.00	0	3
20+00.00	3	3
20+08.74	2	1
Station After Bridge L	Uncl. Exc. (cu. yd.)	Embt (cu. yd.)
21+26.26	0	0
21+50.00	4	10
21+75.00	3	10
22+00.00	1	9
22+20.00	0	3

8/23/99

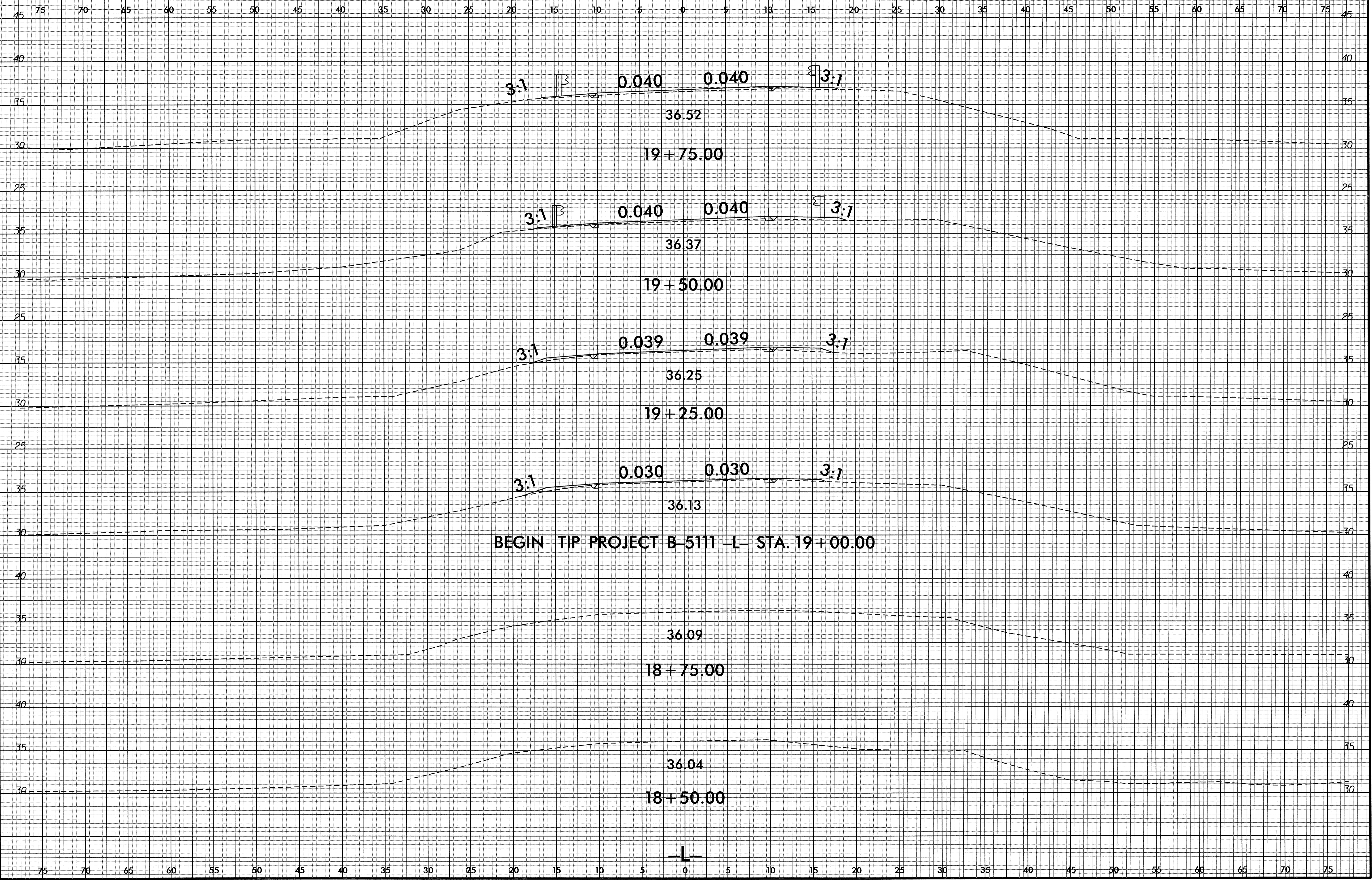

09-OCT-2013 08:34  
P:\PROJECTS\B-5111\Fig-XP1.dgn  
\$\$\$\$\$

8/23/99

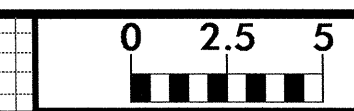

PROJ. REFERENCE NO.  
B-5111

SHEET NO.  
X-2

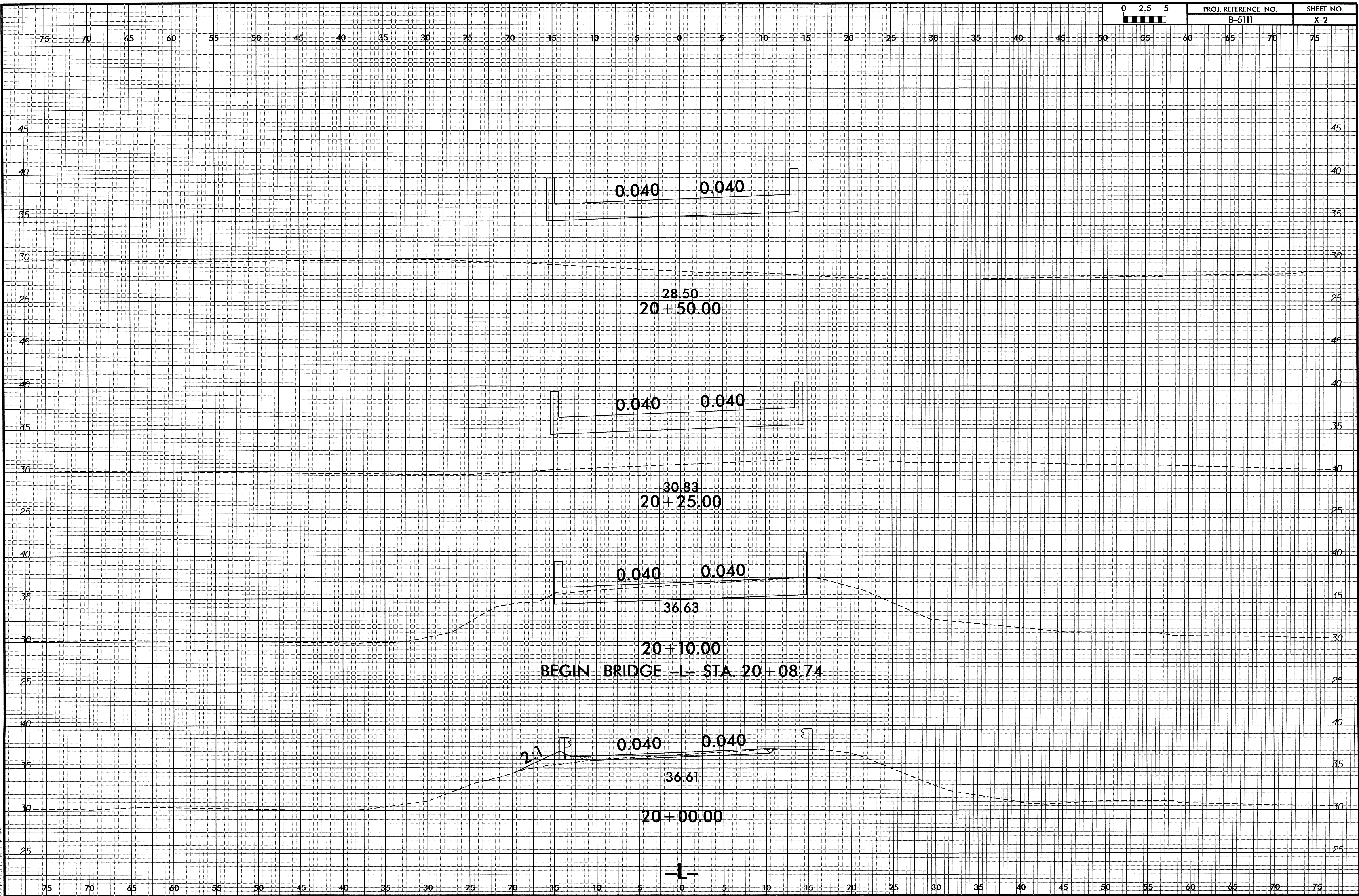

09-OCT-2013 09:24  
B:\305\B\111\_Rdy\_xpl.dgn

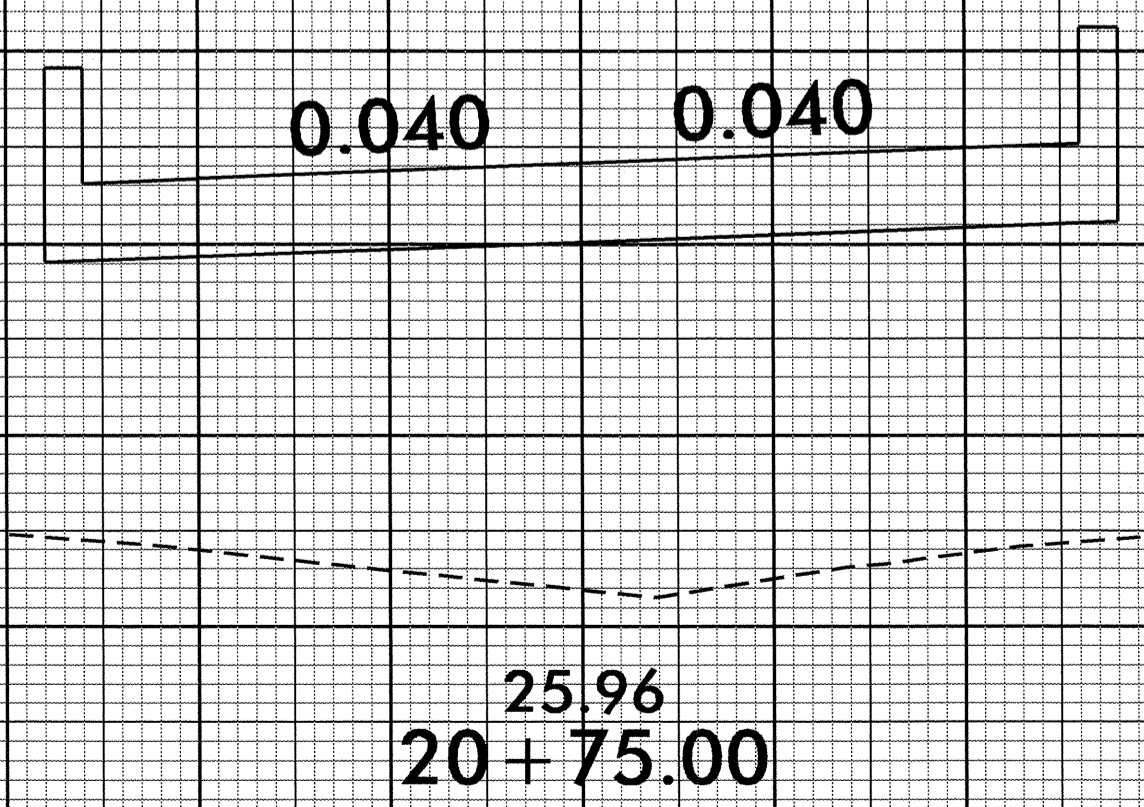
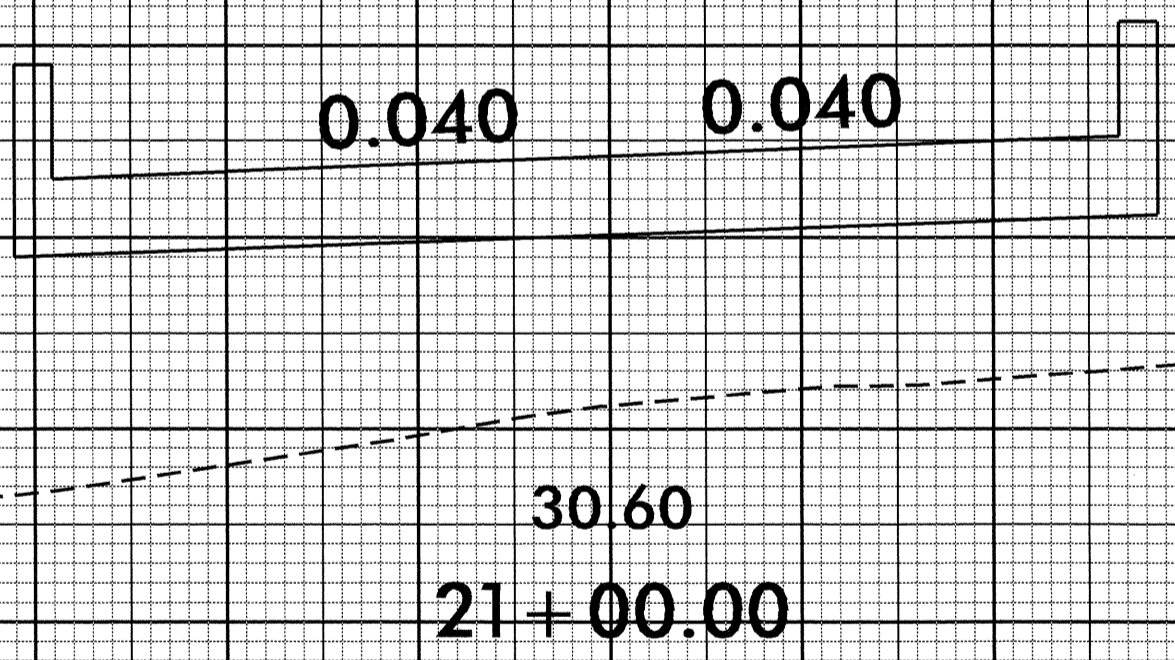
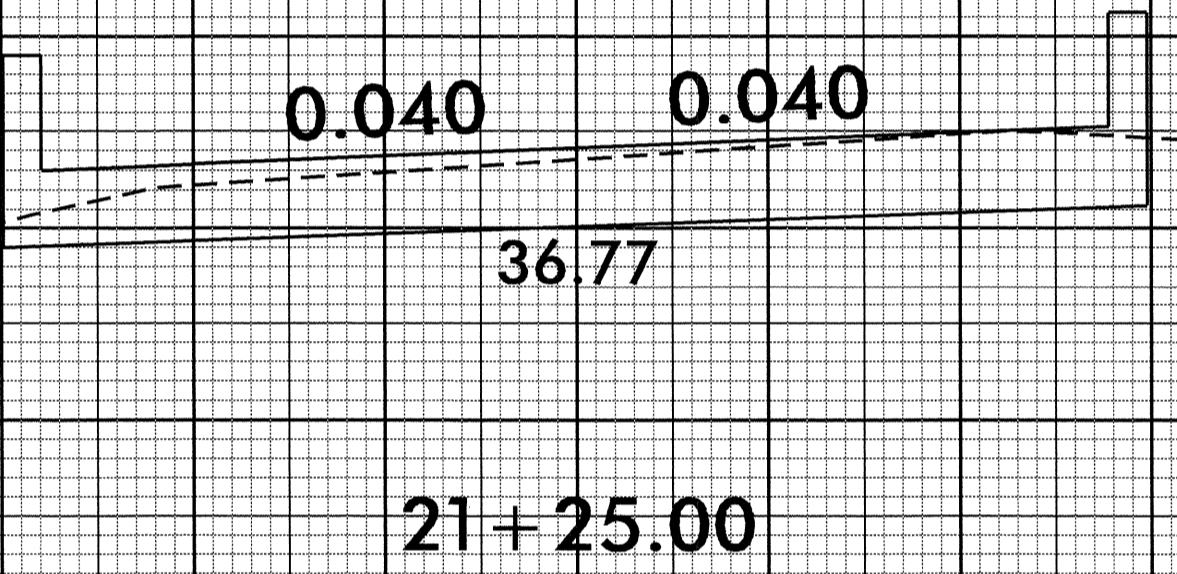
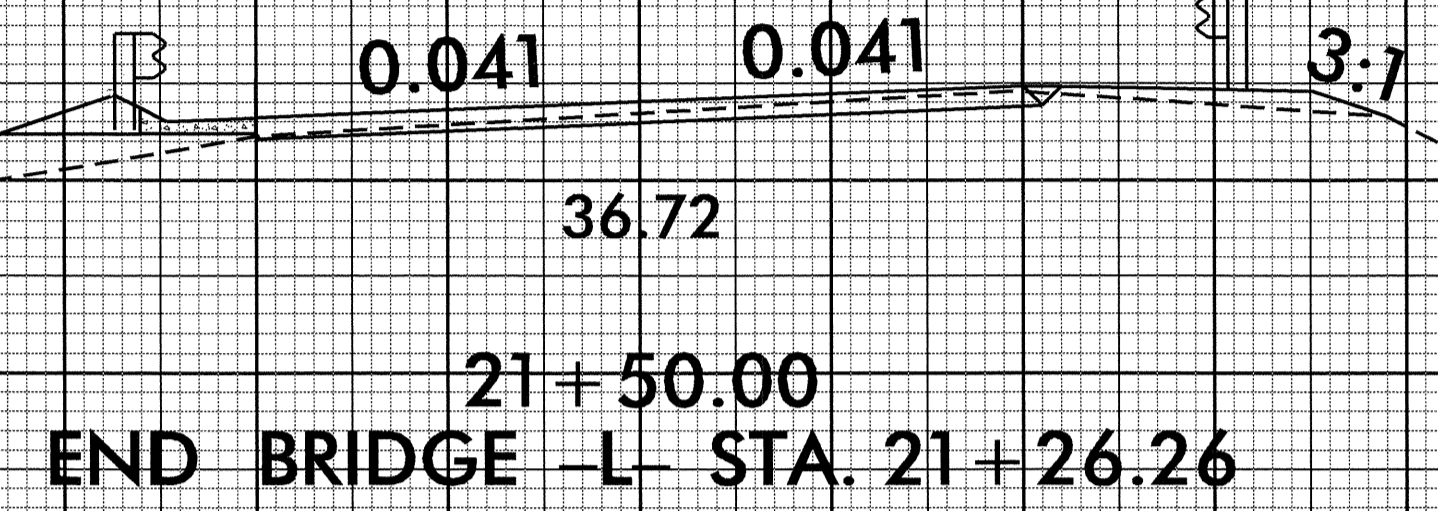
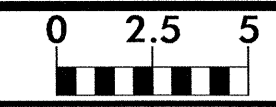

8/23/99

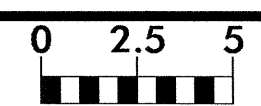

PROJ. REFERENCE NO.	SHEET NO.
B-5111	X-4

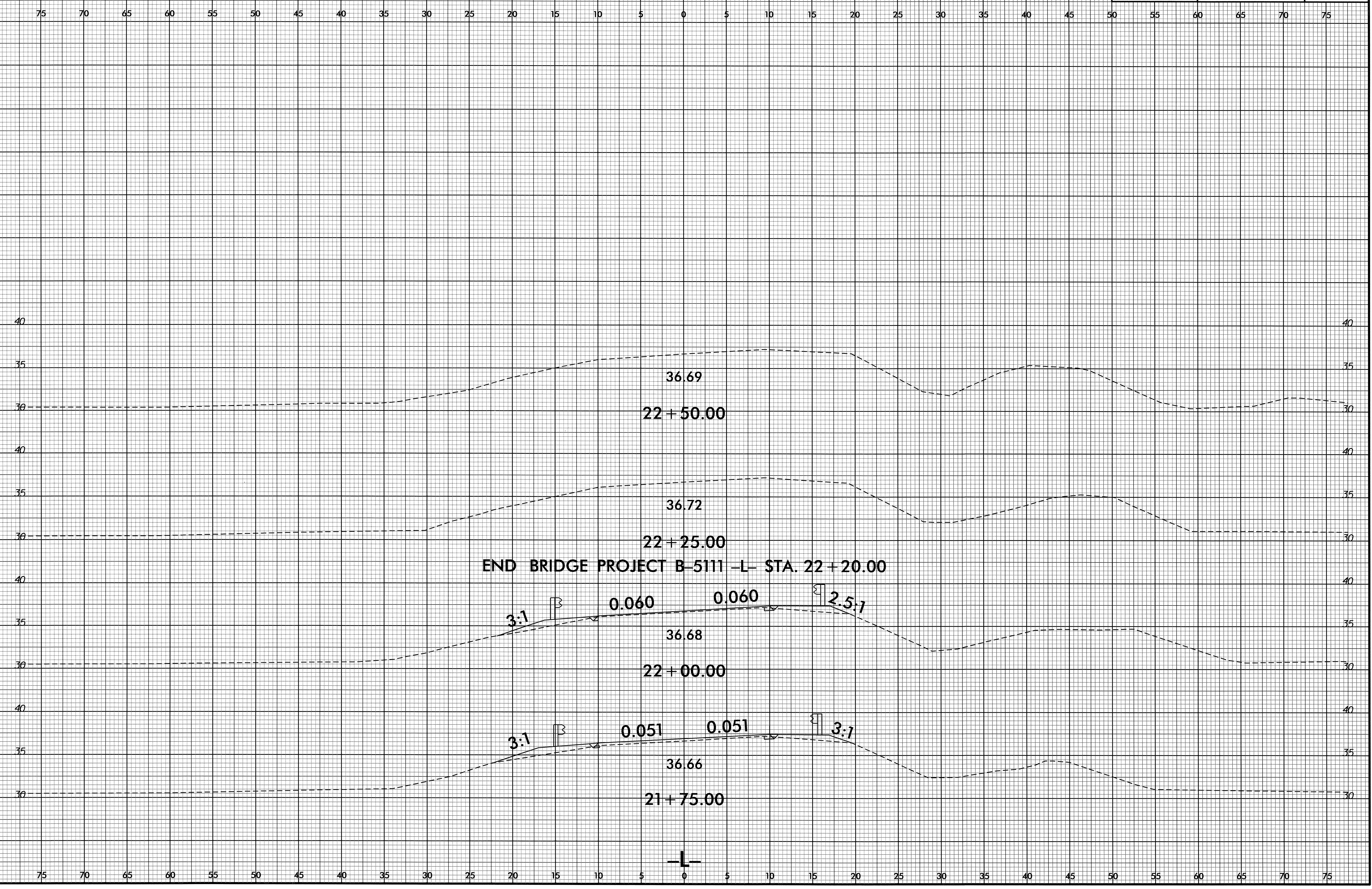

09-OCT-2013 08:33:45 111\_Rdy\_xpl.dgn  
3388028710101