

STATE OF NORTH CAROLINA  
DIVISION OF HIGHWAYS

**TRANSPORTATION MANAGEMENT PLAN**

**DARE COUNTY**



**PHASE II, NC 12 LONG-TERM IMPROVEMENTS AT PEA ISLAND**

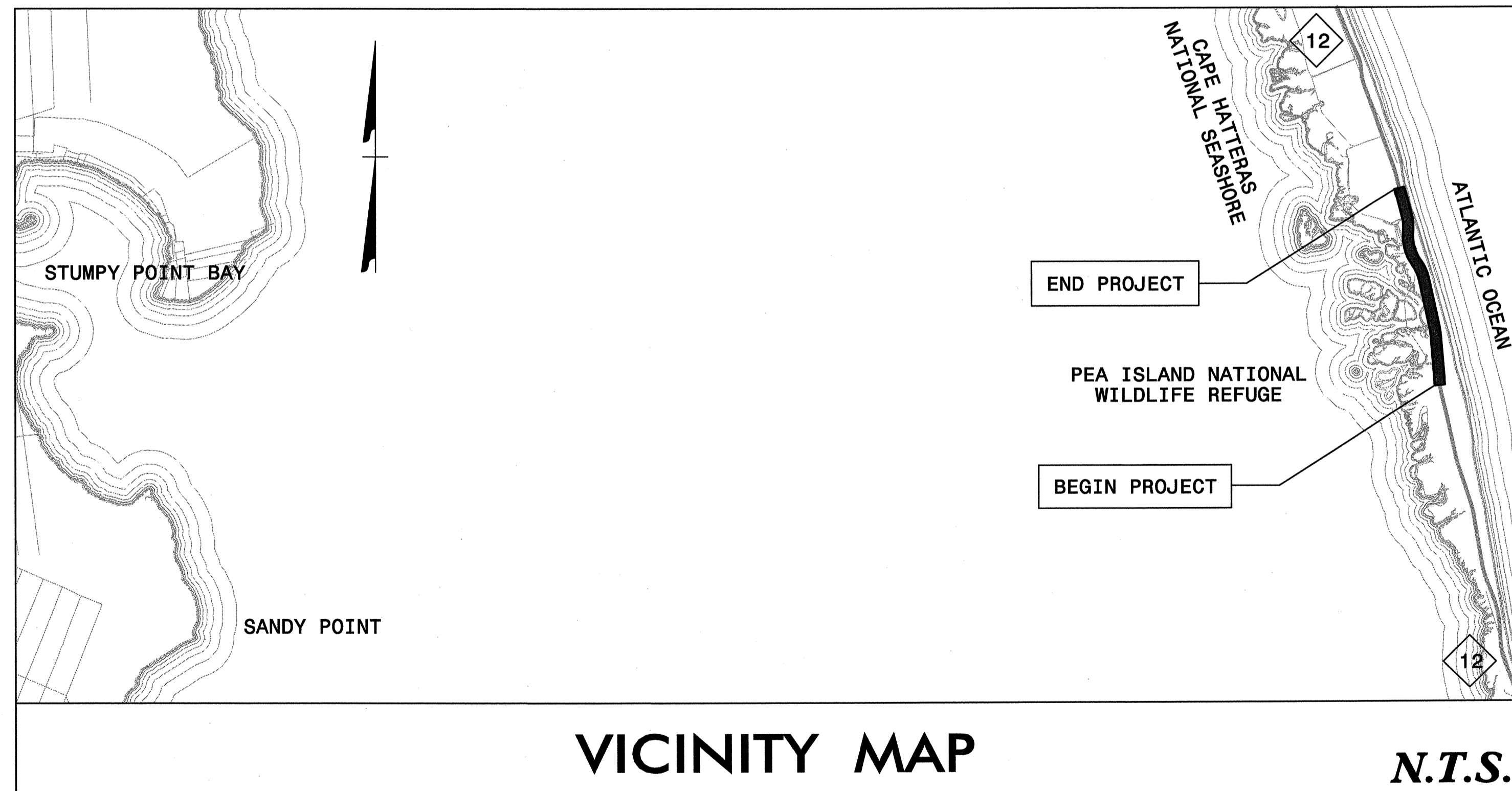

**INDEX OF SHEETS**

SHEET NO.	TITLE
TMP-1	TITLE SHEET, AND INDEX OF SHEETS
TMP-1A	LIST OF APPLICABLE ROADWAY STANDARD DRAWINGS, LEGEND, AND TEMPORARY PAVEMENT MARKING
TMP-1B & TMP-1C	TRANSPORTATION OPERATIONS PLAN
TMP-2A	PORTABLE CONCRETE BARRIER AT TEMPORARY SHORING LOCATIONS
TMP-2B	TEMPORARY SHORING DATA
TMP-3 & TMP-3A	TEMPORARY TRAFFIC CONTROL PHASING
TMP-4 - TMP-9	TEMPORARY TRAFFIC CONTROL PHASE I DETAIL
TMP-10 - TMP-15	TEMPORARY TRAFFIC CONTROL PHASE II DETAIL
TMP-16 - TMP-18	TEMPORARY TRAFFIC CONTROL PHASE III DETAIL
TMP-19 - TMP-20	TEMPORARY TRAFFIC CONTROL PHASE IV DETAIL
TMP-21 - TMP-26	TEMPORARY TRAFFIC CONTROL PHASE V DETAIL

SHEET NO.

TMP-1

FINAL  
TRAFFIC CONTROL PLANS

APPROVED: *Kit A. Persiani*  
DATE: 5/28/2013

SEAL

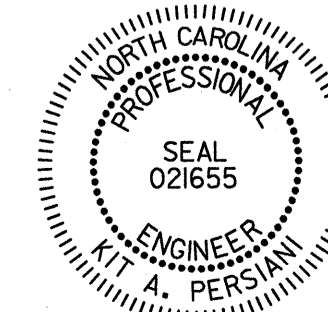

STV / Ralph Whitehead Associates, Inc.  
1000 West Morehead St., Ste. 200  
Charlotte, NC 28208  
NC License Number F-0991

KIT A. PERSIANI, PE  
TRAFFIC ENGINEER

MAAMOON K. ABDELAZIZ  
TRANSPORTATION DESIGNER

N.C.D.O.T. WORK ZONE TRAFFIC CONTROL  
1561 MAIL SERVICE CENTER (MSC) RALEIGH, NC 27699-1561  
750 N. GREENFIELD PARKWAY, GARNER, NC 27529 (DELIVERY)  
PHONE: (919) 773-2800 FAX: (919) 771-2745

J. STUART BOURNE, P.E. STATE TRAFFIC MANAGEMENT ENGINEER  
J. STEVE KITE, P.E. TRAFFIC CONTROL PROJECT ENGINEER  
DAVID BISSETTE, P.E. TRAFFIC CONTROL PROJECT DESIGN ENGINEER  
TRAFFIC CONTROL DESIGN ENGINEER

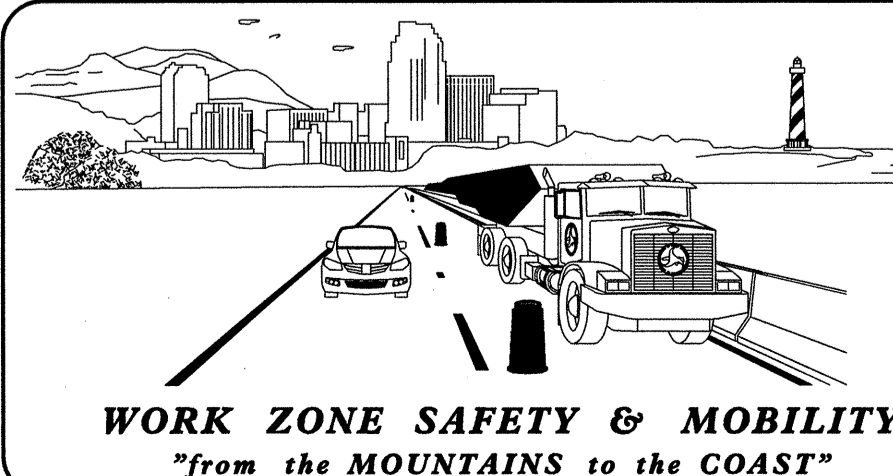
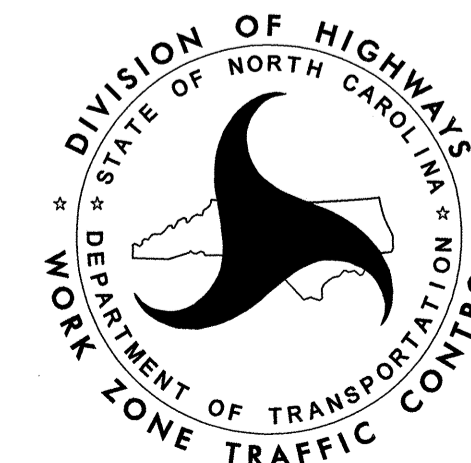

R:\Traffic\TrafficControl\CP\WG\PE\A\TC\_TMP\_01.dgn

5/24/2013

**PROJECT: B-2500A**

# ROADWAY STANDARD DRAWINGS

REV. SEPTEMBER 2011

ROADWAY STANDARD DRAWINGS

THE FOLLOWING ROADWAY STANDARDS AS APPEAR IN "ROADWAY STANDARD DRAWINGS" - PROJECT SERVICES UNIT - N.C. DEPARTMENT OF TRANSPORTATION - RALEIGH, N.C., DATED JANUARY 2012 ARE APPLICABLE TO THIS PROJECT AND BY REFERENCE HEREBY ARE CONSIDERED A PART OF THESE PLANS:

STD. NO.	TITLE
1101.01	WORK ZONE WARNING SIGNS
1101.02	TEMPORARY LANE CLOSURES
1101.04	TEMPORARY SHOULDER CLOSURES
1101.05	WORK ZONE VEHICLE ACCESSES
1101.11	TRAFFIC CONTROL DESIGN TABLES
1110.01	STATIONARY WORK ZONE SIGNS
1110.02	PORTABLE WORK ZONE SIGNS
1130.01	DRUMS
1135.01	CONES
1145.01	BARRICADES
1150.01	FLAGGING DEVICES
1160.01	TEMPORARY CRASH CUSHION
1170.01	PORTABLE CONCRETE BARRIER
1180.01	SKINNY - DRUM
1205.01	PAVEMENT MARKINGS - LINE TYPES AND OFFSETS
1205.02	PAVEMENT MARKINGS - TWO LANE AND MULTILANE ROADWAYS
1250.01	RAISED PAVEMENT MARKERS - INSTALLATION SPACING
1251.01	RAISED PAVEMENT MARKERS - (PERMANENT AND TEMPORARY)
1261.01	GUARDRAIL AND BARRIER DELINEATORS - INSTALLATION SPACING
1261.02	GUARDRAIL AND BARRIER DELINEATORS - TYPES AND MOUNTING
1262.01	GUARDRAIL END DELINEATION
1264.01	OBJECT MARKERS - TYPES
1264.02	OBJECT MARKERS - INSTALLATION

# LEGEND

## GENERAL

- DIRECTION OF TRAFFIC FLOW
- DIRECTION OF PEDESTRIAN TRAFFIC FLOW
- EXIST. PVMT.
- NORTH ARROW
- PROPOSED PVMT.

WORK AREA

REMOVAL

TEMPORARY PAVEMENT

WEDGING

## TRAFFIC CONTROL DEVICES

- BARRICADE (TYPE III)
- CONE
- DRUM SKINNY DRUM TUBULAR MARKER
- TEMPORARY CRASH CUSHION
- FLASHING ARROW PANEL (TYPE C)
- FLAGGER
- LAW ENFORCEMENT
- TRUCK MOUNTED IMPACT ATTENUATOR (TMIA)
- CHANGEABLE MESSAGE SIGN

## TEMPORARY SIGNING

- PORTABLE SIGN
- STATIONARY SIGN
- STATIONARY OR PORTABLE SIGN

## SIGNALS

- EXISTING
- PROPOSED
- TEMPORARY

## PAVEMENT MARKINGS

- EXISTING LINES
- TEMPORARY LINES

## PAVEMENT MARKERS

- CRYSTAL/CRYSTAL
- CRYSTAL/RED
- YELLOW/YELLOW

## PAVEMENT MARKING SYMBOLS

- PAVEMENT MARKING SYMBOLS

## TEMPORARY PAVEMENT MARKING

### PAINT 4"

- PA WHITE EDGELINE
- PB YELLOW EDGELINE
- PI YELLOW DOUBLE CENTERLINE

PROJ. REFERENCE NO. B-2500A	SHEET NO. TMP-1A
 STV/Ralph Whitehead Associates, Inc. 1000 West Morehead St., Ste. 200 Charlotte, NC 28208 NC License Number F-0991	

APPROVED: DATE: 5/24/2013	 M. A. PERSIANI ENGINEER NO. 021655		ROADWAY STANDARD DRAWINGS & LEGEND
------------------------------	--	--	---------------------------------------



# PROJECT NOTES

CHANGES MAY BE REQUIRED WHEN PHYSICAL DIMENSIONS IN THE DETAIL DRAWINGS, STANDARD DETAILS, AND ROADWAY DETAILS ARE NOT ATTAINABLE TO MEET FIELD CONDITIONS OR RESULT IN DUPLICATE OR UNDESIRABLE OVERLAPPING OF DEVICES. MODIFICATION MAY INCLUDE: MOVING, SUPPLEMENTING, COVERING, OR REMOVAL OF DEVICES AS DIRECTED BY THE ENGINEER.

THE FOLLOWING GENERAL NOTES APPLY AT ALL TIMES FOR THE DURATION OF THE CONSTRUCTION PROJECT EXCEPT WHEN OTHERWISE NOTED IN THE PLAN OR DIRECTED BY THE ENGINEER.

**TIME RESTRICTIONS**

A) DO NOT CLOSE OR NARROW TRAVEL LANES AS FOLLOWS:

ROAD NAME	DAY AND TIME RESTRICTIONS
NC 12 (-L-)	SEPTEMBER 15 THRU JUNE 13 FRIDAY 3:00 PM TO MONDAY 7:00 AM
	JUNE 14 THRU SEPTEMBER 14 TUESDAY THRU THURSDAY 6:00 AM TO 8:00 PM FRIDAY 6:00 AM TO MONDAY 8:00 PM

B) DO NOT CLOSE OR NARROW TRAVEL LANES DURING HOLIDAYS AND SPECIAL EVENTS AS FOLLOWS:

ROAD NAME	HOLIDAY
NC 12 (-L-)	1. FOR ANY UNEXPECTED OCCURRENCE THAT CREATES UNUSUALLY HIGH TRAFFIC VOLUMES, AS DIRECTED BY THE ENGINEER.
	2. FOR NEW YEAR'S, BETWEEN THE HOURS OF 6:00 A.M. DECEMBER 31st TO 8:00 P.M. JANUARY 2ND. IF NEW YEAR'S DAY IS ON A FRIDAY, SATURDAY, SUNDAY, OR MONDAY THEN UNTIL 8:00 P.M. THE FOLLOWING TUESDAY.
	3. FOR EASTER, BETWEEN THE HOURS OF 6:00 A.M. THURSDAY AND 8:00 P.M. MONDAY.
	4. FOR MEMORIAL DAY, BETWEEN THE HOURS OF 6:00 A.M. FRIDAY TO 8:00 P.M. TUESDAY.
	5. FOR INDEPENDENCE DAY, BETWEEN THE HOURS OF 6:00 A.M. THE DAY BEFORE INDEPENDENCE DAY AND 8:00 P.M. THE DAY AFTER INDEPENDENCE DAY.  IF INDEPENDENCE DAY IS ON A FRIDAY, SATURDAY, SUNDAY OR MONDAY THEN BETWEEN THE HOURS OF 6:00 A.M. THE THURSDAY BEFORE INDEPENDENCE DAY AND 8:00 P.M. THE TUESDAY AFTER INDEPENDENCE DAY.
	6. FOR LABOR DAY, BETWEEN THE HOURS OF 6:00 A.M. FRIDAY AND 8:00 P.M. TUESDAY.
	7. FOR THANKSGIVING DAY, BETWEEN THE HOURS OF 6:00 A.M. TUESDAY TO 8:00 P.M. MONDAY.
	8. FOR CHRISTMAS, BETWEEN THE HOURS OF 6:00 A.M. THE FRIDAY BEFORE THE WEEK OF CHRISTMAS DAY AND 8:00 P.M. THE FOLLOWING TUESDAY AFTER THE WEEK OF CHRISTMAS.

C) DO NOT STOP TRAFFIC AS FOLLOWS:

ROAD NAME	DAY AND TIME RESTRICTIONS	DURATION AND OPERATION
NC 12 (-L-)	SEPTEMBER 15 THRU JUNE 13 FRIDAY 3:00 PM TO MONDAY 7:00 AM	30 MINS. FOR HANGING GIRDERS OR DELIVERIES
	JUNE 14 THRU SEPTEMBER 14 TUESDAY THRU THURSDAY 6:00 AM TO 8:00 PM FRIDAY 6:00 AM TO MONDAY 8:00 PM	

D) DO NOT CONDUCT ANY HAULING OPERATIONS AGAINST THE FLOW OF TRAFFIC OF AN OPEN TRAVELWAY UNLESS THE HAULING OPERATION IS PROTECTED BY BARRIER OR GUARDRAIL OR AS DIRECTED BY THE ENGINEER.

**LANE AND SHOULDER CLOSURE REQUIREMENTS**

- E) REMOVE LANE CLOSURE DEVICES FROM THE LANE WHEN WORK IS NOT BEING PERFORMED BEHIND THE LANE CLOSURE OR WHEN A LANE CLOSURE IS NO LONGER NEEDED OR AS DIRECTED BY THE ENGINEER.
- F) WHEN PERSONNEL AND/OR EQUIPMENT ARE WORKING WITHIN 15 FT OF AN OPEN TRAVEL LANE, CLOSE THE NEAREST OPEN SHOULDER USING ROADWAY STANDARD DRAWING NO. 1101.04 UNLESS THE WORK AREA IS PROTECTED BY BARRIER OR GUARDRAIL OR A LANE CLOSURE IS INSTALLED.
- G) WHEN PERSONNEL AND/OR EQUIPMENT ARE WORKING ON THE SHOULDER ADJACENT TO AN UNDIVIDED FACILITY AND WITHIN 5 FT OF AN OPEN TRAVEL LANE, CLOSE THE NEAREST OPEN TRAVEL LANE USING ROADWAY STANDARD DRAWING NO. 1101.02 UNLESS THE WORK AREA IS PROTECTED BY BARRIER OR GUARDRAIL.  
  
WHEN PERSONNEL AND/OR EQUIPMENT ARE WORKING ON THE SHOULDER ADJACENT TO A DIVIDED FACILITY AND WITHIN 10 FT OF AN OPEN TRAVEL LANE, CLOSE THE NEAREST OPEN TRAVEL LANE USING ROADWAY STANDARD DRAWING NO. 1101.02 UNLESS THE WORK AREA IS PROTECTED BY BARRIER OR GUARDRAIL.
- H) WHEN PERSONNEL AND/OR EQUIPMENT ARE WORKING WITHIN A LANE OF TRAVEL OF AN UNDIVIDED OR DIVIDED FACILITY, CLOSE THE LANE ACCORDING TO THE TRAFFIC CONTROL PLANS, ROADWAY STANDARD DRAWINGS, OR AS DIRECTED BY THE ENGINEER. CONDUCT THE WORK SO THAT ALL PERSONNEL AND/OR EQUIPMENT REMAIN WITHIN THE CLOSED TRAVEL LANE.
- I) DO NOT WORK SIMULTANEOUSLY WITHIN 15 FT ON BOTH SIDES OF AN OPEN TRAVELWAY, RAMP, OR LOOP WITHIN THE SAME LOCATION UNLESS PROTECTED WITH GUARDRAIL OR BARRIER.
- J) PROVIDE TRAFFIC CONTROL FOR APPROPRIATE LANE CLOSURES FOR SURVEYING DONE BY THE DEPARTMENT.

**PAVEMENT EDGE DROP OFF REQUIREMENTS**

- K) BACKFILL AT A 6:1 SLOPE UP TO THE EDGE AND ELEVATION OF EXISTING PAVEMENT IN AREAS ADJACENT TO AN OPENED TRAVEL LANE THAT HAS AN EDGE OF PAVEMENT DROP-OFF AS FOLLOWS:  
  
BACKFILL DROP-OFFS THAT EXCEED 2 INCHES ON ROADWAYS WITH POSTED SPEED LIMITS OF 45 MPH OR GREATER.  
  
BACKFILL DROP-OFFS THAT EXCEED 3 INCHES ON ROADWAYS WITH POSTED SPEED LIMITS LESS THAN 45 MPH.  
  
BACKFILL WITH SUITABLE COMPACTED MATERIAL, AS APPROVED BY THE ENGINEER, AT NO EXPENSE TO THE DEPARTMENT.
- L) DO NOT EXCEED A DIFFERENCE OF 2 INCHES IN ELEVATION BETWEEN OPEN LANES OF TRAFFIC FOR NOMINAL LIFTS OF 1.5 INCHES. INSTALL ADVANCE WARNING "UNEVEN LANES" SIGNS (W8-11) 350 ft IN ADVANCE AND A MINIMUM OF EVERY HALF MILE THROUGHOUT THE UNEVEN AREA.

**TRAFFIC PATTERN ALTERATIONS**

- M) NOTIFY THE ENGINEER TWENTY ONE (21) CALENDAR DAYS PRIOR TO ANY TRAFFIC PATTERN ALTERATION.

**SIGNING**

- N) INSTALL ADVANCE WORK ZONE WARNING SIGNS WHEN WORK IS WITHIN 40 FT FROM THE EDGE OF TRAVEL LANE AND NO MORE THAN THREE (3) DAYS PRIOR TO THE BEGINNING OF CONSTRUCTION.
- O) ENSURE ALL NECESSARY SIGNING IS IN PLACE PRIOR TO ALTERING ANY TRAFFIC PATTERN.
- P) INSTALL BLACK ON ORANGE "DIP" SIGNS (W8-2) AND/OR "BUMP" SIGNS (W8-1) 350 ft IN ADVANCE OF THE UNEVEN AREA, OR AS DIRECTED BY THE ENGINEER.

**TRAFFIC BARRIER**

- Q) INSTALL TEMPORARY BARRIER ACCORDING TO THE TRAFFIC CONTROL PLANS A MAXIMUM OF TWO (2) WEEKS PRIOR TO BEGINNING WORK IN ANY LOCATION. ONCE TEMPORARY BARRIER IS INSTALLED AT ANY LOCATION PROCEED IN A CONTINUOUS MANNER TO COMPLETE THE PROPOSED WORK IN THAT LOCATION UNLESS OTHERWISE STATED IN THE TRAFFIC CONTROL PLANS OR AS DIRECTED BY THE ENGINEER.

DO NOT PLACE BARRIER DIRECTLY ON ANY SURFACE OTHER THAN ASPHALT OR CONCRETE.

ONCE TEMPORARY BARRIER IS INSTALLED AT ANY LOCATION AND NO WORK IS PERFORMED BEHIND THE TEMPORARY BARRIER FOR A PERIOD LONGER THAN TWO (2) MONTHS, REMOVE/RESET TEMPORARY BARRIER AT NO COST TO THE DEPARTMENT UNLESS OTHERWISE STATED IN THE TRAFFIC CONTROL PLANS, TEMPORARY BARRIER IS PROTECTING A HAZARD, OR AS DIRECTED BY THE ENGINEER.

INSTALL TEMPORARY BARRIER WITH THE TRAFFIC FLOW BEGINNING WITH THE UPSTREAM SIDE OF TRAFFIC. REMOVE TEMPORARY BARRIER AGAINST THE TRAFFIC FLOW BEGINNING WITH THE DOWNSTREAM SIDE OF TRAFFIC.

INSTALL AND SPACE DRUMS NO GREATER THAN TWICE THE POSTED SPEED LIMIT (MPH) TO CLOSE OR KEEP THE SECTION OF THE ROADWAY CLOSED UNTIL THE TEMPORARY BARRIER CAN BE PLACED OR AFTER THE TEMPORARY BARRIER IS REMOVED.

- R) PROTECT THE APPROACH END OF MOVABLE/PORTABLE CONCRETE BARRIER AT ALL TIMES DURING THE INSTALLATION AND REMOVAL OF THE BARRIER BY EITHER A TRUCK MOUNTED IMPACT ATTENUATOR (MAXIMUM 72 HOURS) OR A TEMPORARY CRASH CUSHION.

PROTECT THE APPROACH END OF MOVABLE/PORTABLE CONCRETE BARRIER FROM ONCOMING TRAFFIC AT ALL TIMES BY A TEMPORARY CRASH CUSHION UNLESS THE APPROACH END OF MOVABLE/PORTABLE CONCRETE BARRIER IS OFFSET FROM ONCOMING TRAFFIC AS FOLLOWS OR AS SHOWN IN THE PLANS:

POSTED SPEED LIMIT	MINIMUM OFFSET
40 OR LESS	15 FT
45 - 50	20 FT
55	25 FT
60 MPH or HIGHER	30 FT

r:\traffic\trafficcontrol\ncp\nc12\PEA\JC\_TMP\_01B.dgn

5/24/2013

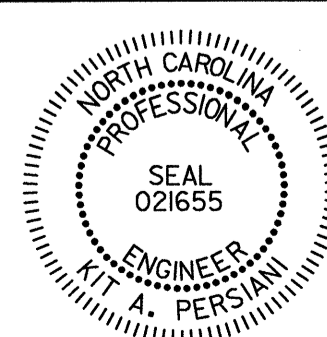
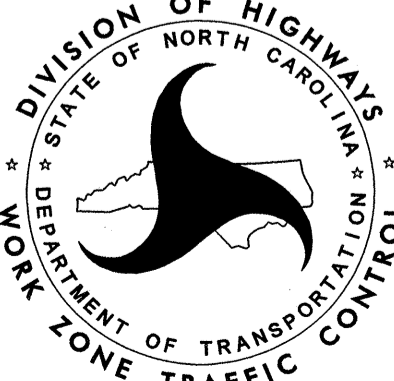
APPROVED: <i>[Signature]</i> DATE: 5/23/2013			<h2 style="margin: 0;">TRANSPORTATION OPERATIONS PLAN</h2>
--	---	---	--



## PROJECT NOTES

### TRAFFIC CONTROL DEVICES

- S) WHEN LANE CLOSURES ARE NOT IN EFFECT SPACE CHANNELIZING DEVICES IN WORK AREAS NO GREATER IN FEET THAN TWICE THE POSTED SPEED LIMIT (MPH) EXCEPT, 10 FT ON-CENTER IN RADII, AND 3 FT OFF THE EDGE OF AN OPEN TRAVELWAY. REFER TO STANDARD SPECIFICATIONS FOR ROADS AND STRUCTURES SECTIONS 1130 (DRUMS), 1135 (CONES) AND 1180 (SKINNY DRUMS) FOR ADDITIONAL REQUIREMENTS.
- T) INSTALL TEMPORARY PAVEMENT MARKINGS AND TEMPORARY PAVEMENT MARKERS ON INTERIM LAYERS OF PAVEMENT AS FOLLOWS:
- | <u>ROAD NAME</u> | <u>MARKING</u> | <u>MARKER</u> |
|------------------|----------------|---------------|
| NC 12 (-L-)      | PAINT          | RAISED        |
- U) PLACE ONE APPLICATION OF PAINT FOR TEMPORARY TRAFFIC PATTERNS. PLACE A SECOND APPLICATION OF PAINT SIX (6) MONTHS AFTER THE INITIAL APPLICATION AND EVERY SIX MONTHS AS DIRECTED BY THE ENGINEER.
- V) TIE PROPOSED PAVEMENT MARKING LINES TO EXISTING PAVEMENT MARKING LINES.
- W) REMOVE/REPLACE ANY CONFLICTING/DAMAGED PAVEMENT MARKINGS AND MARKERS BY THE END OF EACH DAY'S OPERATION.

### LOCAL NOTES

- 1) THE CONTRACTOR SHALL BUILD AS MUCH AS POSSIBLE AWAY FROM TRAFFIC.
- 2) WORK ZONE VEHICLE ACCESS LOCATIONS SHALL FOLLOW ROADWAY STANDARD DRAWING 1101.05, MUST BE SPACED A MINIMUM OF 2500' APART, AND MUST BE APPROVED BY THE ENGINEER.

r:\n\traffic\trafficcontrol\top\NC12PEA\_TC\_TMP\_01B.dgn

5/24/2013

APPROVED: *K.A. Persiani* DATE: 5/28/2013

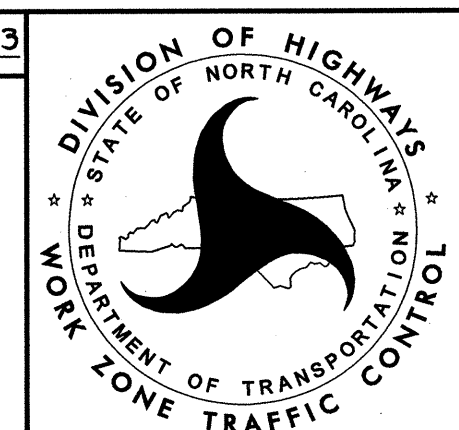
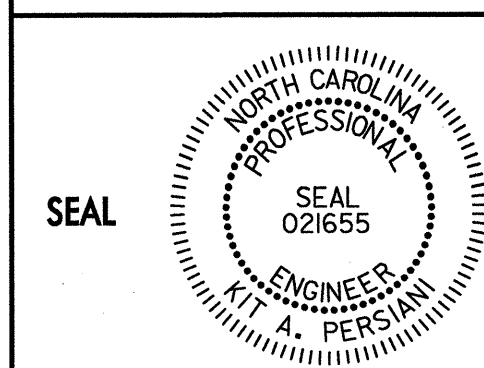

**TRANSPORTATION  
OPERATIONS PLAN**



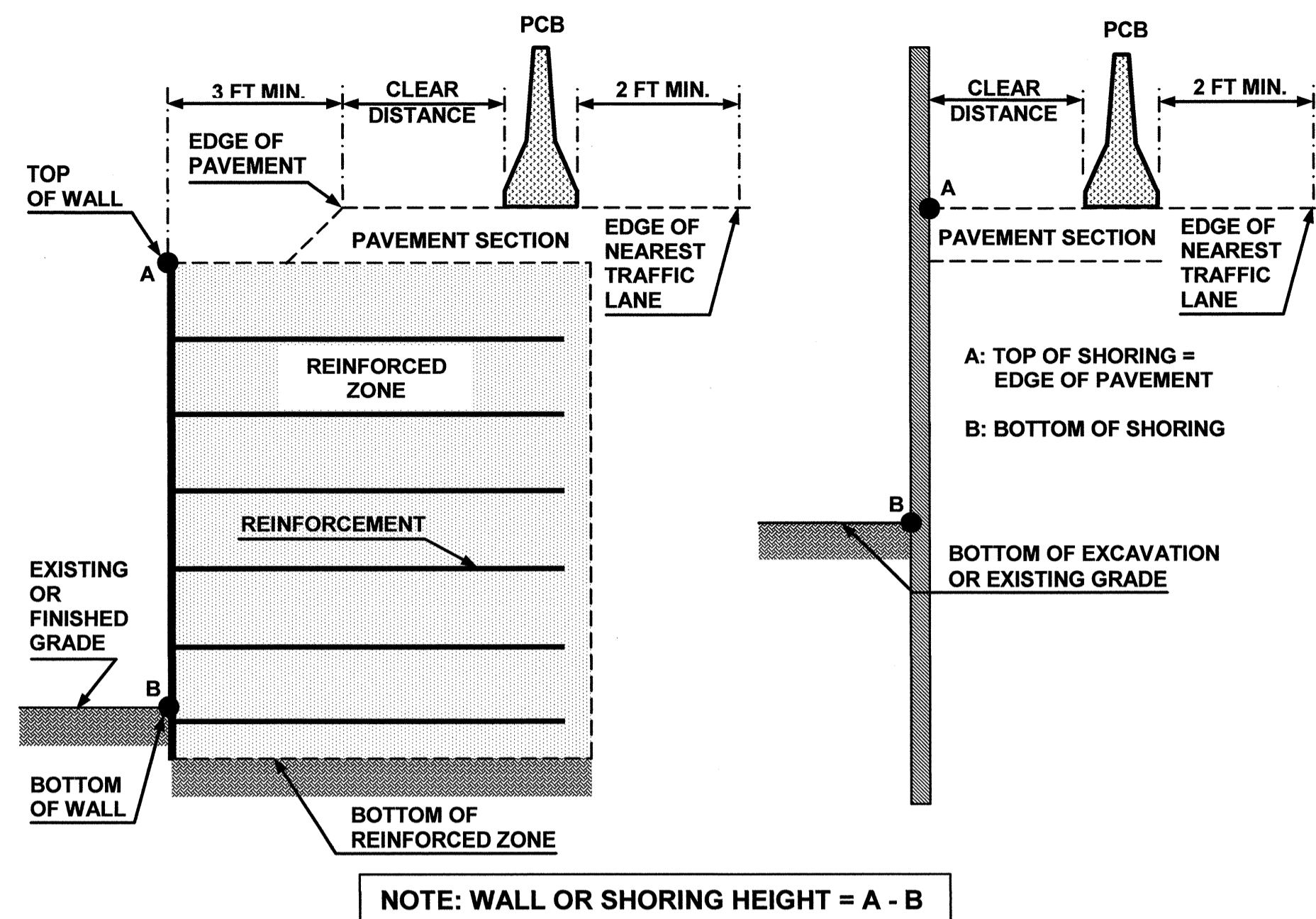

## FIGURE A

### NOTES

- 1- REFER TO THE TRAFFIC CONTROL PLANS FOR TEMPORARY SHORING LOCATIONS AND NOTES.
- 2- REFER TO THE "TEMPORARY SHORING" PROJECT SPECIAL PROVISION FOR INFORMATION ABOUT TEMPORARY SHORING AND PORTABLE CONCRETE BARRIER (PCB).
- 3- PCB IS REQUIRED IF TEMPORARY SHORING IS LOCATED WITHIN THE CLEAR ZONE IN ACCORDANCE WITH THE AASHTO ROADSIDE DESIGN GUIDE. DO NOT PLACE BARRIER DIRECTLY ON ANY SURFACE OTHER THAN ASPHALT OR CONCRETE. (CONTACT NCDOT PAVEMENT MANAGEMENT UNIT FOR APPLICABLE PAVEMENT DESIGN).
- 4- BASED ON THE CLEAR DISTANCE, OFFSET, DESIGN SPEED AND PAVEMENT TYPE, CHOOSE AN UNANCHORED OR ANCHORED PCB FROM THE TABLE SHOWN IN FIGURE B. CLEAR DISTANCE IS DEFINED AS SHOWN IN FIGURE A AND OFFSET IS DEFINED AS SHOWN IN FIGURE B.
- 5- AT THE CONTRACTOR'S OPTION OR IF THE MINIMUM REQUIRED CLEAR DISTANCE IS NOT AVAILABLE, SET PCB NEXT TO AND UP AGAINST THE TRAFFIC SIDE OF THE TEMPORARY SHORING EXCEPT FOR BARRIER ABOVE TEMPORARY WALLS. PCB WITH THE MINIMUM REQUIRED CLEAR DISTANCE IS REQUIRED ABOVE TEMPORARY WALLS.
- 6- USE NCDOT PORTABLE CONCRETE BARRIER (PCB) IN ACCORDANCE WITH ROADWAY STANDARD DRAWING NO. 1170.01 AND SECTION 1170 OF THE STANDARD SPECIFICATIONS.
- 7- PCB REQUIREMENTS FOR TEMPORARY WALLS APPLY TO TEMPORARY MECHANICALLY STABILIZED EARTH (MSE) WALLS AND TEMPORARY SOIL NAIL WALLS.
- 8- SET PCB WITH A MINIMUM HORIZONTAL DISTANCE OF 2 FT BETWEEN THE FRONT FACE OF THE BARRIER AND THE EDGE OF THE NEAREST TRAFFIC LANE AS SHOWN IN FIGURE A UNLESS OTHERWISE SHOWN IN THE PLANS AND OR AS APPROVED BY THE ENGINEER.
- 9- FOR PCB ABOVE AND BEHIND TEMPORARY WALLS, PROVIDE A MINIMUM DISTANCE OF 3 FT BETWEEN THE EDGE OF PAVEMENT AND THE WALL FACE AS SHOWN IN FIGURE A. IF THESE MINIMUM REQUIRED DISTANCES ARE NOT AVAILABLE, CONTACT THE ENGINEER.
- 10- TABLE SHOWN IN FIGURE B IS BASED ON NCDOT RESEARCH PROJECT NO. 2005-010 WITH VEHICLE TYPE USED FOR NCHRP 350 CRASH TESTS. BARRIER DEFLECTIONS AND RESULTING MINIMUM REQUIRED CLEAR DISTANCES MIGHT VARY SIGNIFICANTLY FOR LARGER HEAVIER VEHICLES, RUNS OF BARRIER LESS THAN 200 FT IN LENGTH AND WET OR DRY PAVEMENT.

Barrier Type	Pavement Type	Offset * ft	Design Speed, mph					
			<30	31-40	41-50	51-60	61-70	71-80
Unanchored PCB	Asphalt	<8	24	26	29	32	36	40
		8-14	26	28	31	35	38	42
		14-20	27	29	34	36	39	43
		20-26	28	31	35	38	40	44
		26-32	29	32	36	39	42	45
		32-38	30	34	38	41	43	46
		38-44	31	34	41	43	45	48
	44-50	31	35	41	43	46	49	
	50-56	32	36	42	44	47	50	
	>56	32	36	42	45	47	51	
	Concrete	<8	17	18	21	22	25	26
		8-14	19	20	23	25	26	29
		14-20	22	22	24	26	28	31
		20-26	23	24	26	27	30	34
26-32		24	25	27	28	32	35	
32-38		24	26	27	30	33	36	
38-44		25	26	28	30	34	37	
44-50	26	26	28	32	35	37		
50-56	26	26	28	32	35	38		
>56	26	27	29	32	36	38		
Anchored PCB	Asphalt	All Offsets	24 for All Design Speeds					
Anchored PCB	Concrete (including bridge approach slabs)	All Offsets	12 for All Design Speeds					

\* See Figure Below

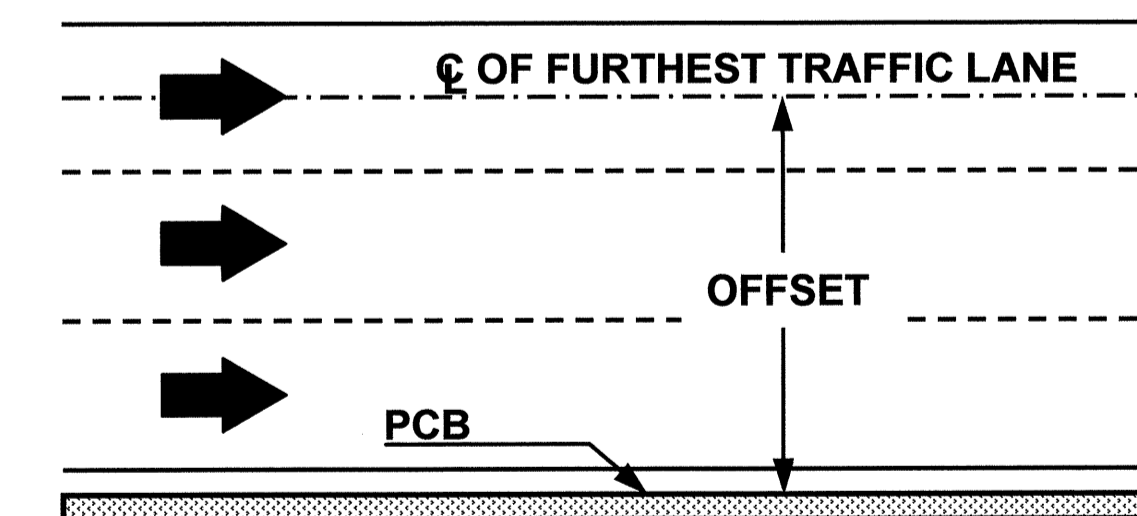

## FIGURE B

APPROVED:  DATE: 06-13-13 		<b>PORTABLE CONCRETE BARRIER AT TEMPORARY SHORING LOCATIONS</b>
-------------------------------	--	---





## PHASING NOTES

### PHASE I

**STEP 1**

INSTALL WORK ZONE ADVANCE WARNING SIGNS ALONG NC 12, IN ACCORDANCE WITH ROADWAY STANDARD DRAWING 1101.01, SHEET 3 OF 3.

**STEP 2**

WORKING AWAY FROM TRAFFIC & USING ROADWAY STANDARD DRAWING 1101.02 SHEET 1 OF 15 BEGIN CONSTRUCTION OF THE BRIDGE FROM -L- STA. 3170+30 +/- TO STA. 3175+80 +/-.

**STEP 3**

WHILE MAINTAINING TRAFFIC ON THE EXISTING ROADWAY AND USING ROADWAY STANDARD DRAWING 1101.02 SHEET 1 OF 15 AS NEEDED, PERFORM THE FOLLOWING AS SHOWN ON TMP-4 THRU TMP-9:

- A) CONSTRUCT TEMPORARY PAVEMENT WIDENING ALONG EXISTING NC 12 FOR THE FOLLOWING STATION RANGES:
  - L- STA. 3112+80± TO STA. 3122+20± RT.
  - L- STA. 3144+80± TO STA. 3158+70± RT.
  - L- STA. 3159+60± TO STA. 3164+80± LT.
  - L- STA. 3184+17± TO STA. 3195+80± RT.
- B) CONSTRUCT TEMPORARY WEDGING, AS NEEDED TO MAINTAIN DRAINAGE, LEFT OF -L- FOR THE FOLLOWING STATION RANGES:
  - L- STA. 3077+94± TO STA. 3110+07±
  - L- STA. 3118+94± TO STA. 3148+13±
  - L- STA. 3162+25± TO STA. 3166+25±
- C) INSTALL TEMPORARY PAVEMENT MARKINGS AS SHOWN FOR THE FOLLOWING STATION RANGES:
  - L- STA. 3076+46± TO STA. 3169+57±
  - L- STA. 3176+33± TO STA. 3215+11±
- D) SHIFT TRAFFIC TO A TWO-LANE, TWO-WAY PATTERN ONTO NEWLY CONSTRUCTED TEMPORARY PAVEMENT.

### PHASE II

**STEP 1**

WORKING AWAY FROM TRAFFIC & USING ROADWAY STANDARD DRAWING 1101.02 SHEET 1 OF 15 AND/OR 1101.04 AS NEEDED, PERFORM THE FOLLOWING UP TO THE EXISTING PAVEMENT ELEVATION OF NC 12 (AT TIE INS):

- A) CONSTRUCT TEMPORARY DETOUR FROM -DET- STA. 3078+13± TO STA. 3160+19± CONSTRUCT CROSSOVER -X1- FROM -X1- STA. 3157+02± TO STA. 3158+05±
- B) INSTALL TEMPORARY SHORING LOCATION #1 FROM -L- STA. 3159+25± TO -L- STA. 3168+50± 33'-69' RT. CONSTRUCT -DET- STA. 3160+47± TO STA. 3168+49± AND CROSSOVER -X1- FROM STA. 3158+46± TO STA. 3161+58±.
- C) INSTALL TEMPORARY SHORING LOCATION #2 FROM -L- STA. 3177+15± TO -L- STA. 3183+25± 40'-63' RT. CONSTRUCT -DET- STA. 3176+81± TO STA. 3180+58± AND CROSSOVER -X2- FROM -X2- STA. 3179+58± TO STA. 3183+77±.
- D) CONSTRUCT -DET- STA. 3181+02± TO STA. 3213+88±.
- E) INSTALL TYPE III BARRICADES AS SHOWN ON TMP-10, TMP-13, TMP-14 AND TMP-15.
- F) INSTALL PORTABLE CONCRETE BARRIER AS SHOWN FOR THE FOLLOWING STATION RANGES (SEE LOCAL NOTE 2):
  - DET- STA. 3082+00± TO STA. 3157+02± RT
  - DET- STA. 3161+22± TO STA. 3167+19± LT
  - X1- STA. 3158+41± TO -DET- STA. 3168+73± RT
  - DET- STA. 3176+60± TO -X2- STA. 3183+82± RT
  - DET- STA. 3185+09± TO STA. 3207+15± RT
- G) INSTALL WATER FILLED BARRIER AS SHOWN FOR THE FOLLOWING STATION RANGES:
  - DET- STA. 3157+79± TO STA. 3159+77± RT
  - DET- STA. 3160+53± TO STA. 3160+83± RT
  - DET- STA. 3180+35± TO STA. 3180+50± RT
  - DET- STA. 3181+41± TO STA. 3184+35± RT
  - X1- STA. 3157+78± TO STA. 3158+12± LT
  - X1- STA. 3158+85± TO STA. 3160+82± LT
  - X2- STA. 3180+36± TO STA. 3183+36± LT
  - X2- STA. 3184+07± TO STA. 3184+40± LT
- H) INSTALL TEMPORARY PAVEMENT MARKINGS AS SHOWN FOR THE FOLLOWING STATION RANGES:
  - DET- STA. 3078+43± TO STA. 3160+19±
  - DET- STA. 3160+60± TO STA. 3168+49±
  - DET- STA. 3176+81± TO STA. 3180+58±
  - DET- STA. 3181+02± TO STA. 3213+45±
  - X1- STA. 3157+02± TO STA. 3158+05±
  - X1- STA. 3158+46± TO STA. 3161+57±
  - X2- STA. 3179+58± TO STA. 3183+77±
  - X2- STA. 3184+14± TO STA. 3185+14±
- I) SHIFT VEHICULAR TRAFFIC ON EXISTING NC 12 ONTO A TWO-LANE, TWO WAY PATTERN ONTO NEWLY CONSTRUCTED TEMPORARY DETOUR ALIGNMENT, -DET-, -X1- AND -X2-.

R:\Traffic\TrafficControl\NCP\NCP2PEA\_TC\_TMP\_03.dgn

8/13/2013

APPROVED:  DATE: 8/13/2013			<h3 style="margin: 0;">TEMPORARY TRAFFIC CONTROL PHASING</h3>
----------------------------	--	--	---



## PHASING NOTES (CONTINUED)

### PHASE III

**STEP 1**

- A) AWAY FROM TRAFFIC BEGIN CONSTRUCTION OF THE BRIDGE FROM -L- STA. 3089+00 +/- TO STA. 3147+60 +/- AND FROM -L- STA. 3191+30 +/- TO STA. 3200+60+/-.
- B) INSTALL TEMPORARY SHORING AT THE FOLLOWING LOCATIONS:  
 #3 FROM -L- STA. 3167+85± TO STA. 3168+45±, 2' TO 18' RT  
 #4 FROM -L- STA. 3169+00± TO STA. 3169+35±, 6' TO 10' RT  
 #5 FROM -L- STA. 3176+70± TO STA. 3177+15±, 2' TO 8' RT
- C) AWAY FROM TRAFFIC CONSTRUCT PROPOSED BRIDGE & BRIDGE BENTS BEGINNING AT THE BREACH LOCATION/ TEMPORARY BRIDGE AND WORKING AWAY IN EACH DIRECTION (TO THE NORTH TIE AND TO THE SOUTH TIE) FROM -L- STA. 3163+20.00 TO STA. 3179+30.00 AS SHOWN ON TMP-16 AND TMP-17.

**STEP 2**

WORKING AWAY FROM TRAFFIC & USING ROADWAY STANDARD DRAWING 1101.02 SHEET 1 OF 15 AND/OR 1101.04 AS NEEDED, PERFORM THE FOLLOWING UP TO THE EXISTING PAVEMENT ELEVATION OF NC 12 (AT TIE INS):

- A) CONSTRUCT CROSSOVER -X3- FROM -X3- STA. 3159+00± TO STA. 3163+51±  
 CONSTRUCT CROSSOVER -X4- FROM -X4- STA. 3178+46± TO STA. 3182+16±
- B) INSTALL PORTABLE CONCRETE BARRIER AS SHOWN FOR THE FOLLOWING STATION RANGES:  
 -X3- STA. 3163+01± TO STA. 3163+51± LT  
 -X4- STA. 3178+46± TO STA. 3179+01± LT
- C) INSTALL WATER FILLED BARRIER AS SHOWN FOR THE FOLLOWING STATION RANGES:  
 -X1- STA. 3160+82± TO -DET- STA. 3162+86± LT  
 -X3- STA. 3162+75± TO STA. 3162+93± RT  
 -DET- STA. 3179+10± TO -X2- STA. 3180+36± LT  
 -X4- STA. 3179+09± TO STA. 3179+35± RT
- D) REMOVE PORTABLE CONCRETE BARRIER AS SHOWN FOR THE FOLLOWING STATION RANGES:  
 -DET- STA. 3160+70± TO STA. 3163+45± LT  
 -DET- STA. 3178+46± TO STA. 3180+25± LT
- E) REMOVE WATER FILLED BARRIER AS SHOWN FOR THE FOLLOWING STATION RANGES:  
 -DET- STA. 3159+00± TO STA. 3160+83± RT  
 -DET- STA. 3180+35± TO STA. 3182+17± RT
- F) INSTALL TEMPORARY PAVEMENT MARKINGS AS SHOWN FOR THE FOLLOWING STATION RANGES:  
 -X3- STA. 3159+00± TO STA. 3163+51±  
 -X4- STA. 3178+46± TO STA. 3182+20±
- G) SHIFT VEHICULAR TRAFFIC ONTO A ONE-LANE, ONE WAY PATTERN ONTO REALIGNED TEMPORARY ALIGNMENTS AS SHOWN ON TMP-19.

### PHASE IV

**STEP 1**

- A) AWAY FROM TRAFFIC CONSTRUCT PROPOSED BRIDGE BENT AT -L- STA. 3162+00.00 AND AT -L- STA. 3180+50.00 AS SHOWN ON TMP-19.  
 USING ROADWAY STANDARD DRAWING 1101.02 SHEET 1 OF 15, DELIVERIES OF GIRDERS/MATERIALS ARE TO BE MADE UTILIZING CROSSOVER ALIGNMENT ADJACENT TO BENT LOCATION.
- B) USING ROADWAY STANDARD DRAWING 1101.03 SHEET 8 OF 9 AS NEEDED, INSTALL GIRDERS FOR SPANS FROM -L- STA. 3162+00.00 TO STA. 3163+20.00 AND FROM -L- STA. 3179+30.00 TO STA. 3180+50.00.

### PHASE IV (CONTINUED)

**STEP 2**

WORKING AWAY FROM TRAFFIC & USING ROADWAY STANDARD DRAWING 1101.02 SHEET 1 OF 15 AND/OR 1101.04 AS NEEDED, PERFORM THE FOLLOWING UP TO THE EXISTING PAVEMENT ELEVATION OF NC 12 (AT TIE INS):

- A) WIDEN -DET-/-X3- FROM -DET- STA. 3158+06± TO -X3- STA. 3160+40± RT.  
 WIDEN -DET- FROM -DET- STA. 3181+64± TO STA. 3184+09± RT.  
 CONSTRUCT CROSSOVER -X5- FROM -X5- STA. 3160+40± TO STA. 3162+41±  
 CONSTRUCT CROSSOVER -X6- FROM -X6- STA. 3179+33± TO STA. 3181+70±
- B) INSTALL PORTABLE CONCRETE BARRIER AS SHOWN FOR THE FOLLOWING STATION RANGES:  
 -DET- STA. 3157+02± TO -X5- STA. 3162+41± RT  
 -X6- STA. 3179+01± TO -DET- STA. 3185+09± RT
- C) INSTALL WATER FILLED BARRIER AS SHOWN FOR THE FOLLOWING STATION RANGES:  
 -X5- STA. 3161+00± TO STA. 3162+41± LT  
 -X6- STA. 3179+10± TO STA. 3181+11± LT
- D) REMOVE PORTABLE CONCRETE BARRIER AS SHOWN FOR THE FOLLOWING STATION RANGES:  
 -X1- STA. 3157+02± TO STA. 3157+58± RT  
 -X1- STA. 3157+16± TO STA. 3159+18± RT  
 -X2- STA. 3182+90± TO STA. 3185+14± RT
- E) REMOVE WATER FILLED BARRIER AS SHOWN FOR THE FOLLOWING STATION RANGES:  
 -DET- STA. 3157+79± TO -X3- STA. 3161+00± RT  
 -X1- STA. 3157+78± TO -X5- STA. 3162+41± LT  
 -DET- STA. 3179+10± TO -X2- STA. 3184+40± LT  
 -X4- STA. 3181+11± TO -DET- STA. 3184+35± RT
- F) INSTALL TEMPORARY PAVEMENT MARKINGS AS SHOWN FOR THE FOLLOWING STATION RANGES:  
 -DET- STA. 3156+51± TO -X5- STA. 3162+41±  
 -X6- STA. 3179+01± TO STA. -DET- 3181+70±
- G) SHIFT VEHICULAR TRAFFIC ONTO A ONE-LANE, ONE WAY PATTERN ONTO REALIGNED TEMPORARY ALIGNMENTS -X5- AND -X6- AS SHOWN ON TMP-24 AND TMP-25.

### PHASE V

**STEP 1**

- A) AWAY FROM TRAFFIC CONSTRUCT PROPOSED BRIDGE BENT AT -L- STA. 3160+80.00 AND AT -L- STA. 3181+70.00 AS SHOWN ON TMP-24 AND TMP-25.  
 USING ROADWAY STANDARD DRAWING 1101.02 SHEET 1 OF 15, DELIVERIES OF GIRDERS/MATERIALS ARE TO BE MADE UTILIZING CROSSOVER ALIGNMENT ADJACENT TO BENT LOCATION.
- B) USING ROADWAY STANDARD DRAWING 1101.03 SHEET 8 OF 9 AS NEEDED, INSTALL GIRDERS FOR SPANS FROM -L- STA. 3160+80.00 TO STA. 3162+00.00 AND FROM -L- STA. 3180+50.00 TO STA. 3181+70.00.
- C) AWAY FROM TRAFFIC COMPLETE/CONSTRUCT REMAINDER OF BRIDGE, CONSTRUCT ROADWAY APPROACHES, & RETAINING WALLS ON THE NORTH AND SOUTH TIES.
- D) REMOVE TRAFFIC CONTROL DEVICES & SHIFT TRAFFIC TO FINAL PATTERN ON -L-.

### PHASE VI



**STEP 1**

- A) WORKING AWAY FROM TRAFFIC & USING ROADWAY STANDARD DRAWING 1101.04 AS NEEDED, TEMPORARILY CLOSE AND CONSTRUCT THE REFUGE DRIVEWAY FROM -ACCESS- STA. 3083+11.33 TO STA. 3087+27.65 AND REOPEN THE REFUGE DRIVEWAY TO TRAFFIC WHEN COMPLETE.

**STEP 2**

- WORKING AWAY FROM TRAFFIC & USING ROADWAY STANDARD DRAWING 1101.02 SHEET 1 OF 15 AND/OR 1101.04 AS NEEDED, PERFORM THE FOLLOWING:
- A) REMOVE TEMPORARY CONCRETE BARRIER FROM TEMPORARY DETOUR.
- B) INSTALL PERMANENT PAVEMENT MARKINGS ON THE REFUGE DRIVEWAY FROM -ACCESS- STA. 3083+11± TO STA. 3138+50±.
- C) SAWCUT AND REMOVE TEMPORARY DETOUR PAVEMENT AND TEMPORARY BRIDGE.
- D) REMOVE ALL WARNING SIGNS & TRAFFIC CONTROL DEVICES.

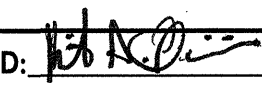
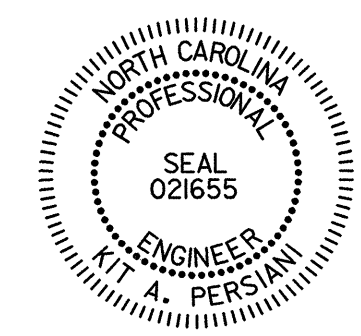
R:\TrafficControl\CP\NIC2PEA\_TC\_TMP\_03.dgn 9/19/2013

APPROVED:  DATE: 9/19/2013			<h2 style="margin: 0;">TEMPORARY TRAFFIC CONTROL PHASING</h2>
---	---	---	---

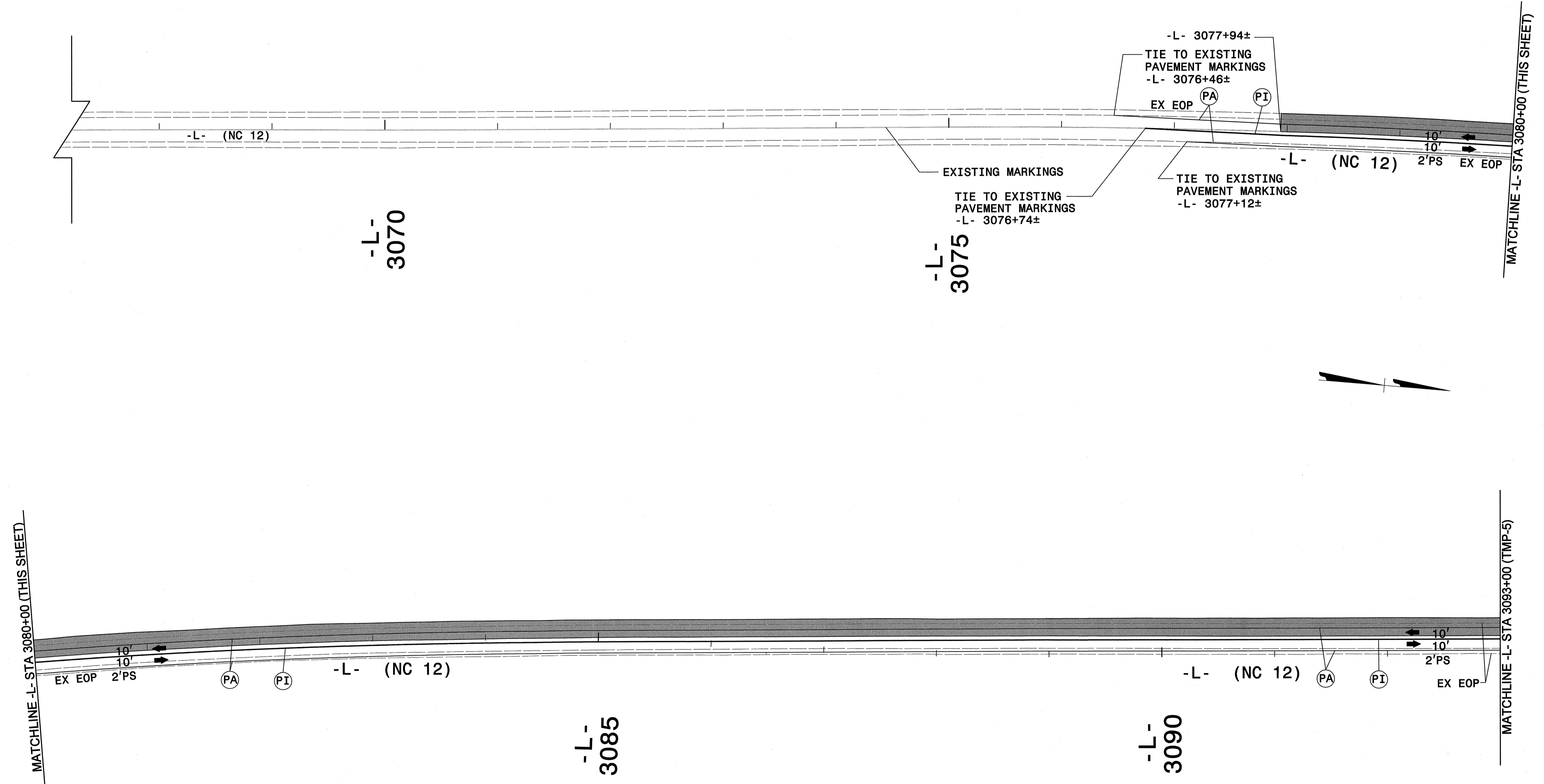

5/24/2013 r:\traffic\trafficcontrol\nc\2500A\TC\_TMP\_04.dgn

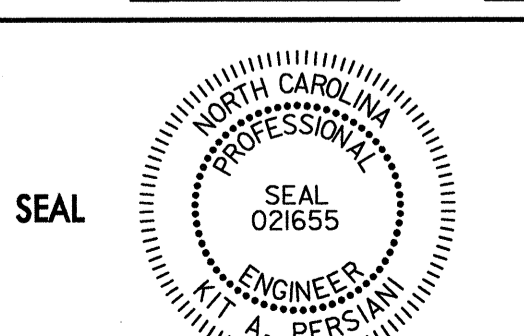
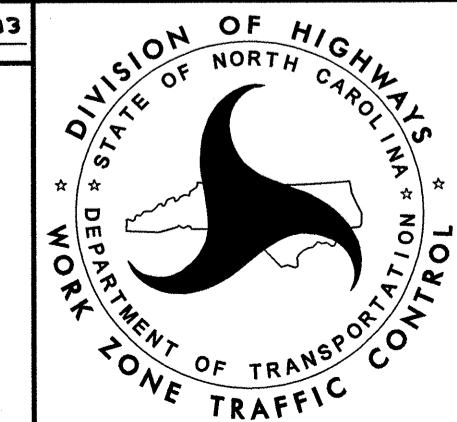
APPROVED: <i>Hit A. Persini</i> DATE: 5/28/2013 		<b>TEMPORARY TRAFFIC CONTROL          PHASE I DETAIL</b>
--	---	--

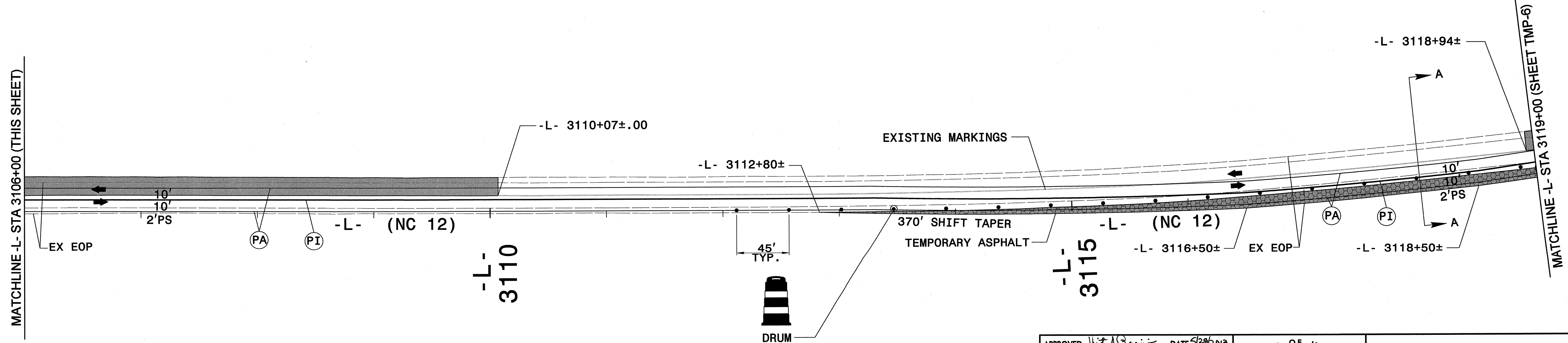
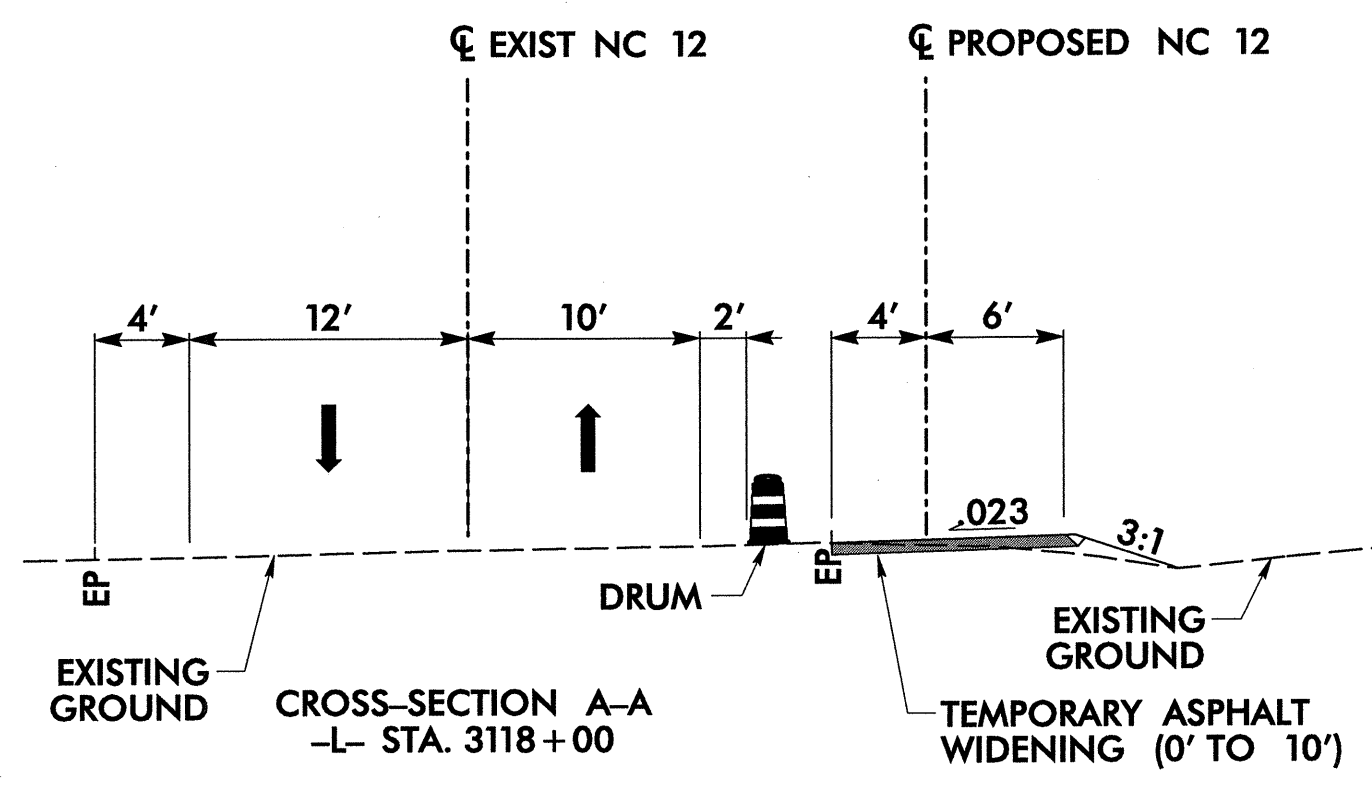
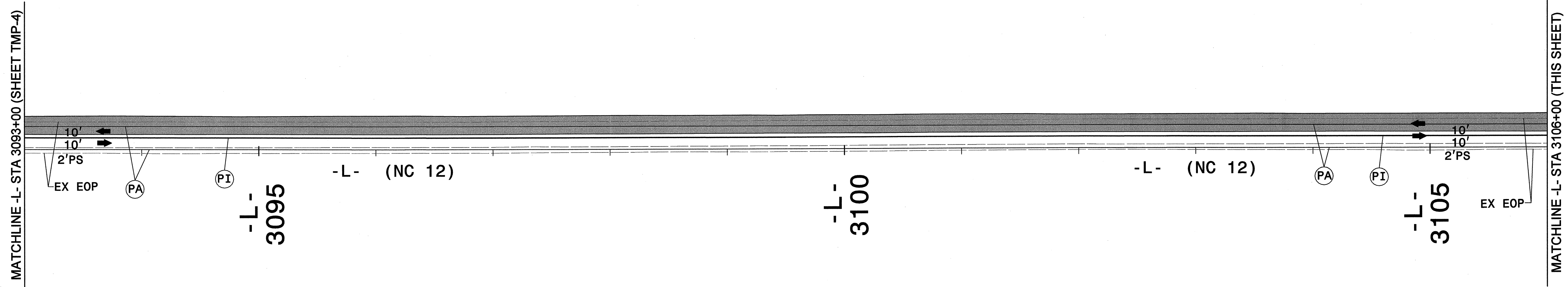

5/24/2013 r:\Traffic\TrafficControl\Ncp\NC12PEA\_TC\_TMP\_05.dgn

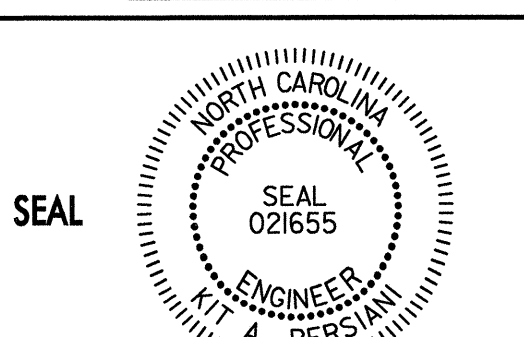
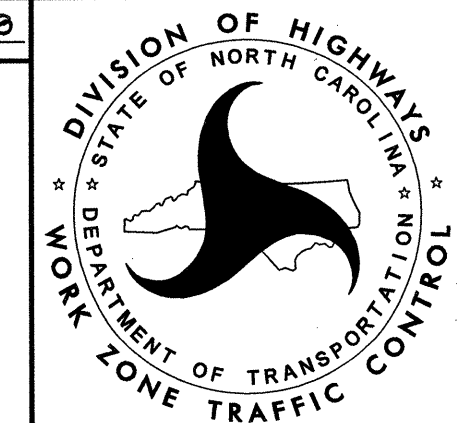
APPROVED: <i>Kit A. Persini</i> DATE: 5/28/2013 		<b>TEMPORARY TRAFFIC CONTROL PHASE I DETAIL</b>
--	---	---



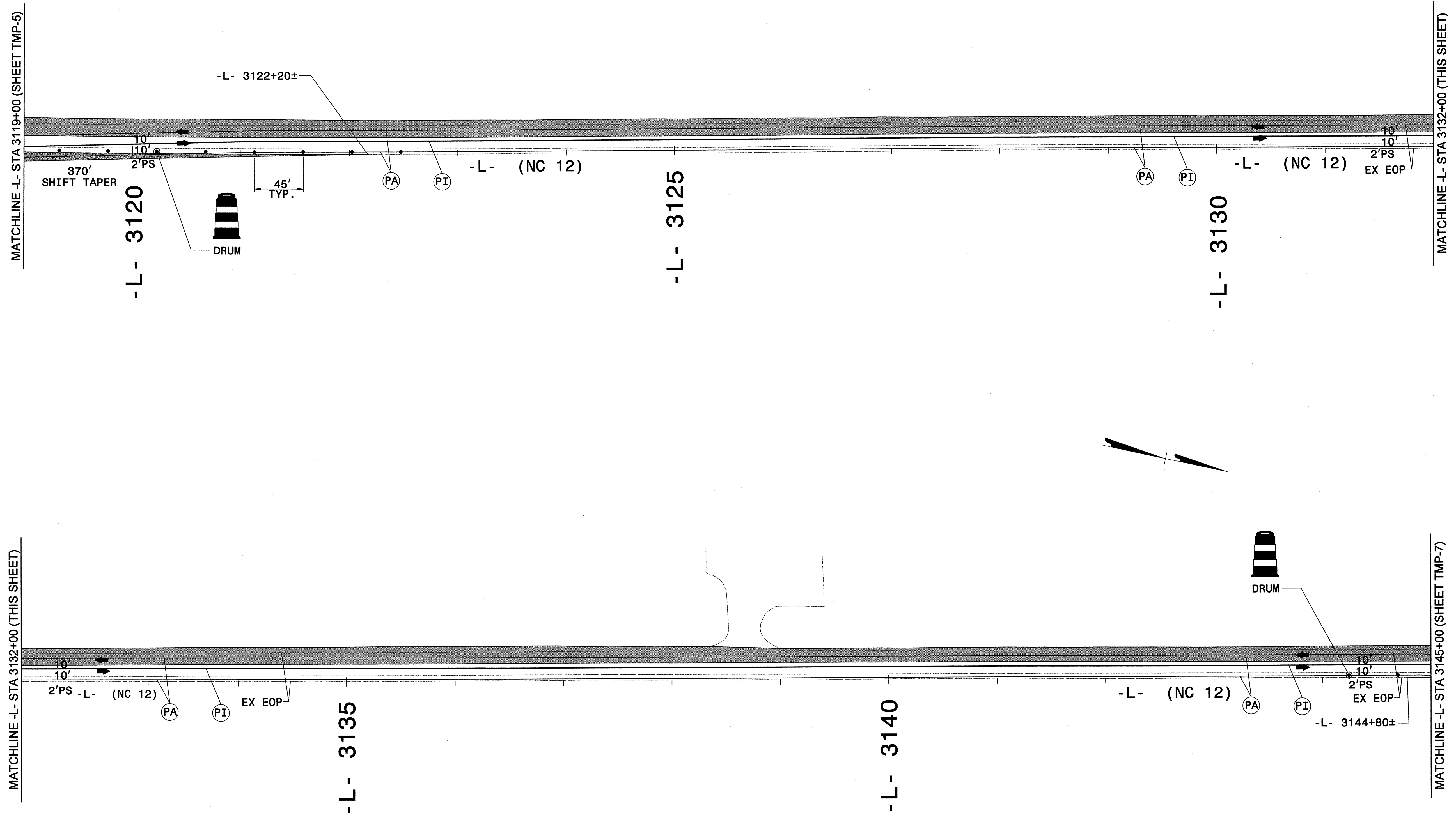

5/24/2013 r:\traffic\trafficcontrol\nc12\PEA\_TC\_TMP\_06.dgn

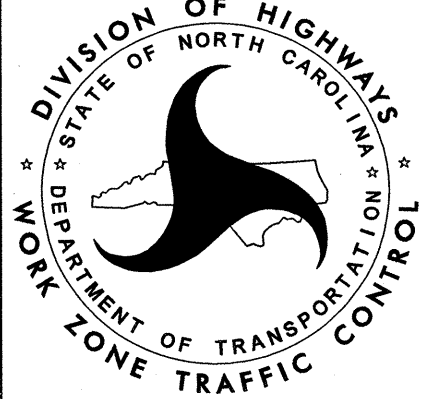
APPROVED: <i>H. A. Persiani</i> DATE: 5/29/2013			<b>TEMPORARY TRAFFIC CONTROL          PHASE I DETAIL</b>
---	---	---	--

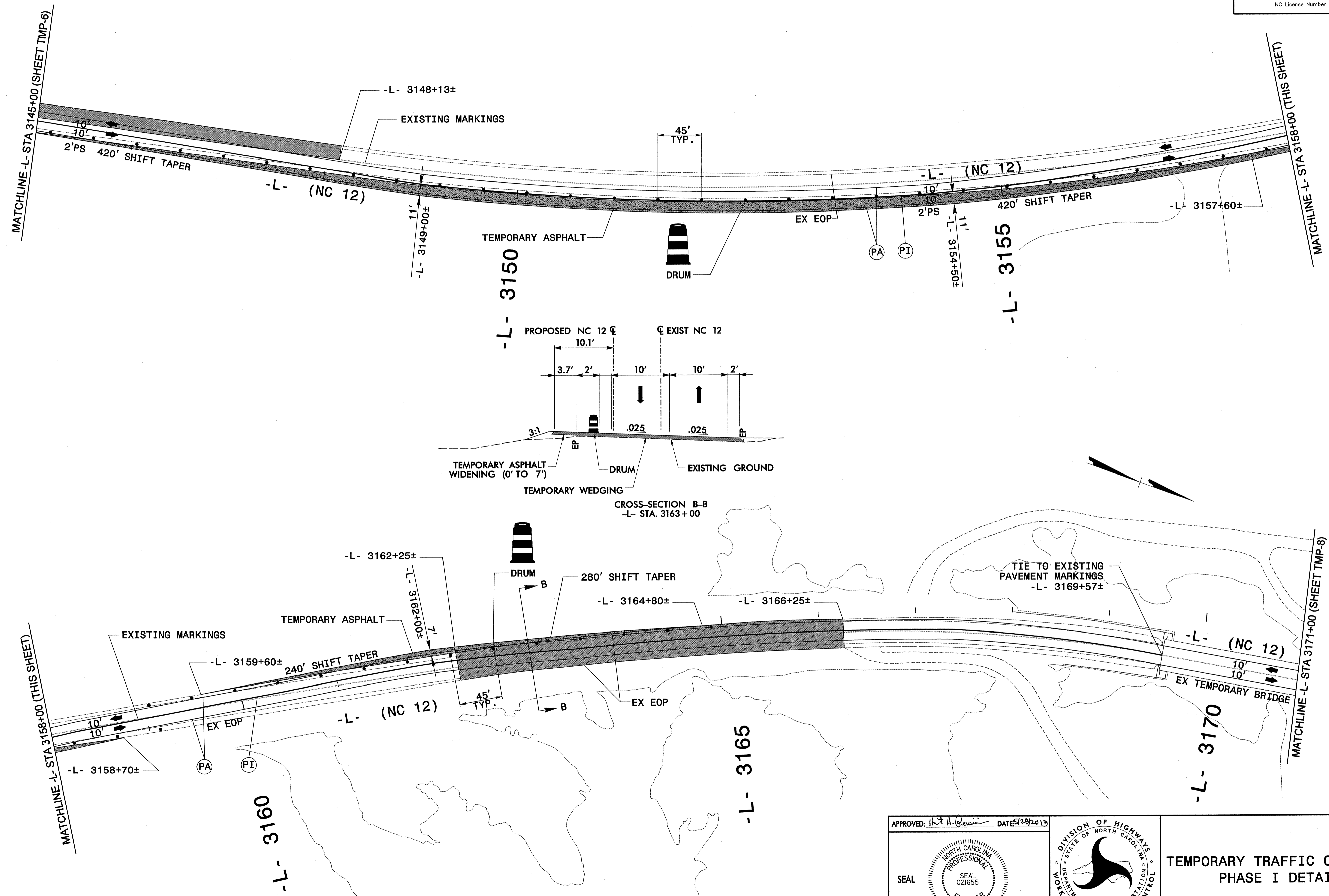

5/24/2013 r:\traffic\trafficcontrol\nc12\PEA\_TC\_TMP\_07.dgn

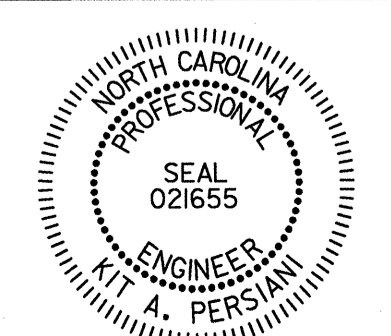
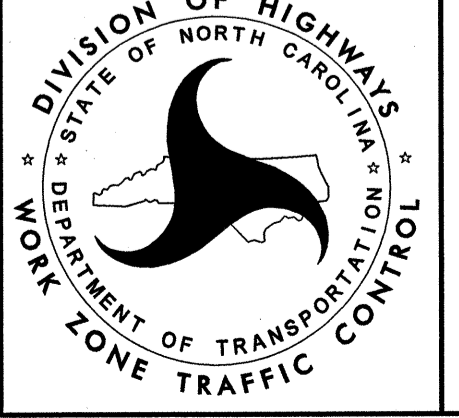
APPROVED: <i>H.A. Persiani</i> DATE: 5/20/2013			<b>TEMPORARY TRAFFIC CONTROL PHASE I DETAIL</b>
--	---	---	---

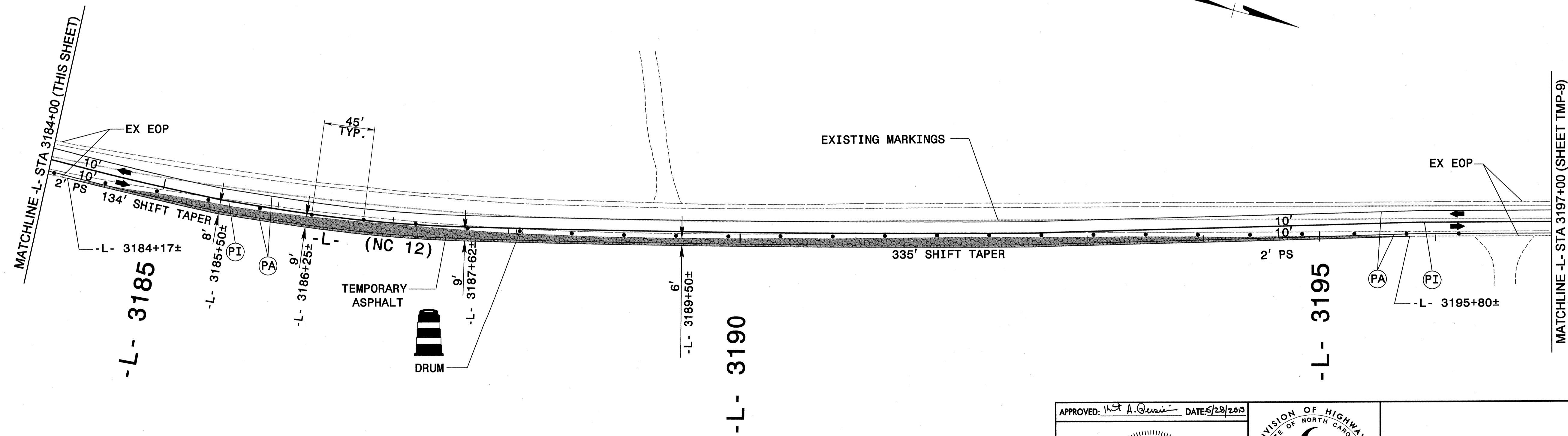
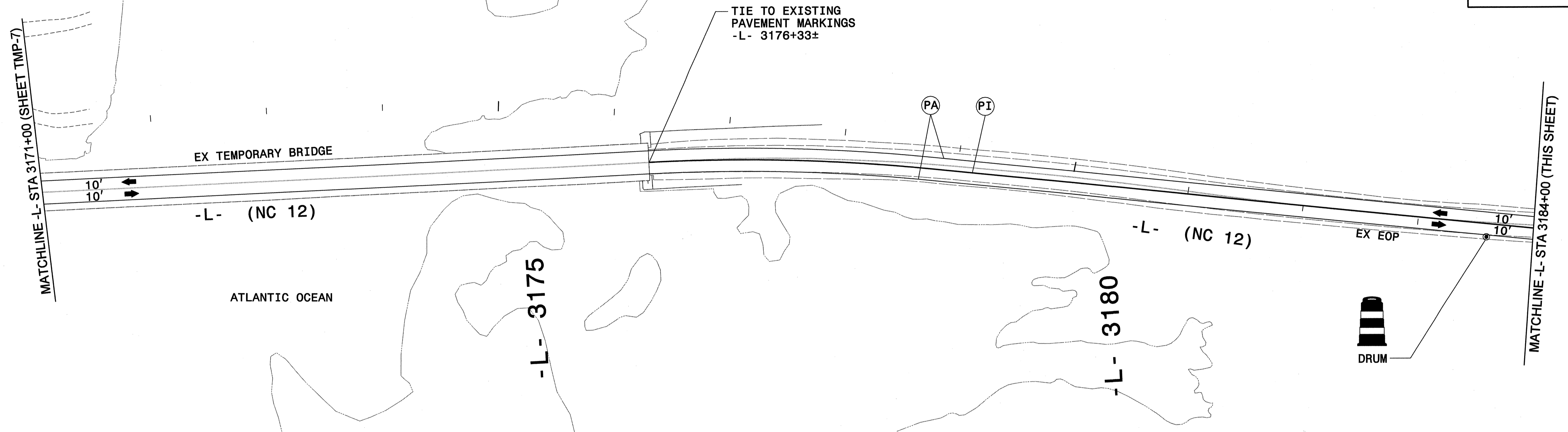

5/24/2013 r:\traffic\trafficontra\nc\2500A\JC\_TMP\_08.dgn

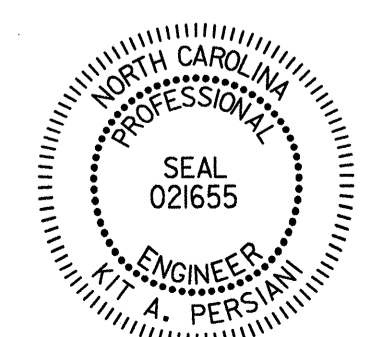
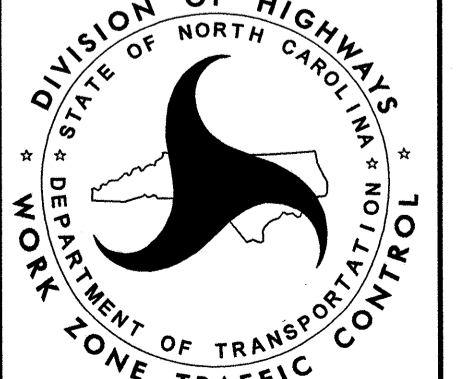
APPROVED: <i>A. Quasi</i> DATE: 5/28/2013			<b>TEMPORARY TRAFFIC CONTROL PHASE I DETAIL</b>
---	---	---	---



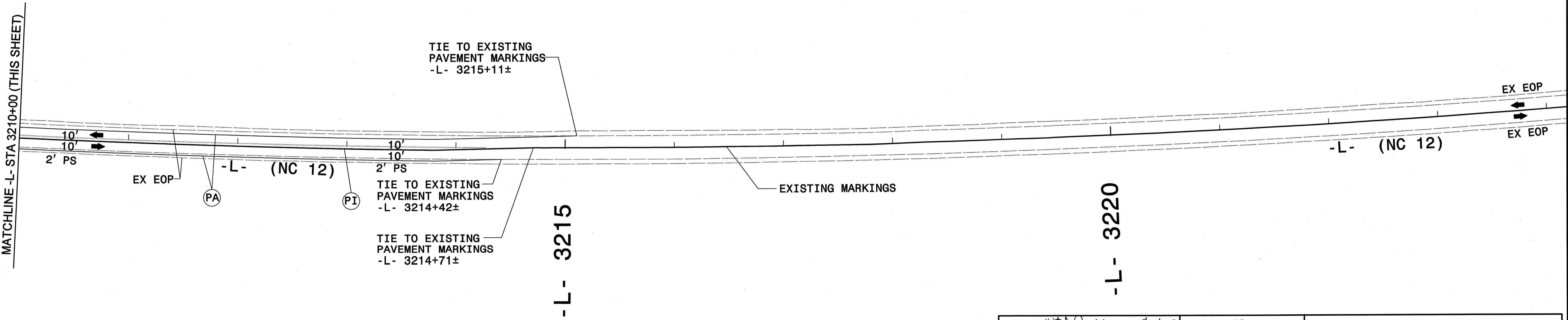
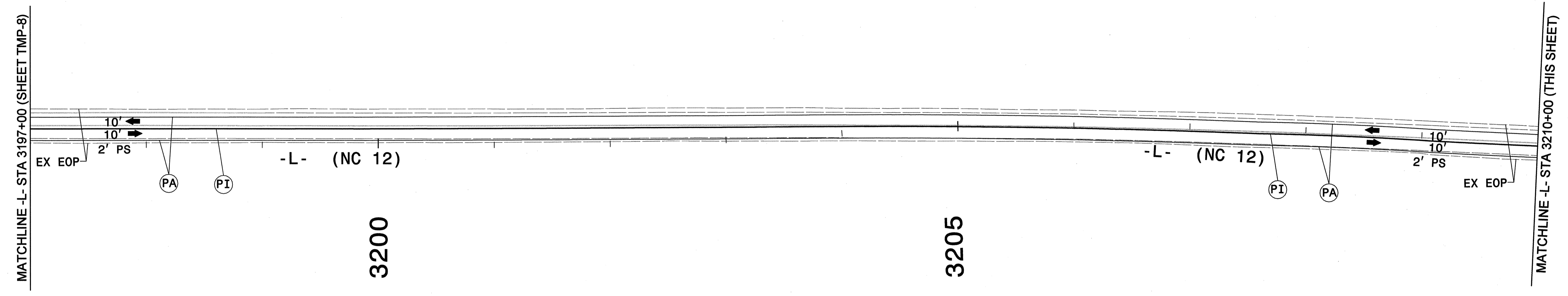

5/24/2013 r:\traffic\trafficcontrol\nc12\PEA\_TC\_TMP\_09.dgn

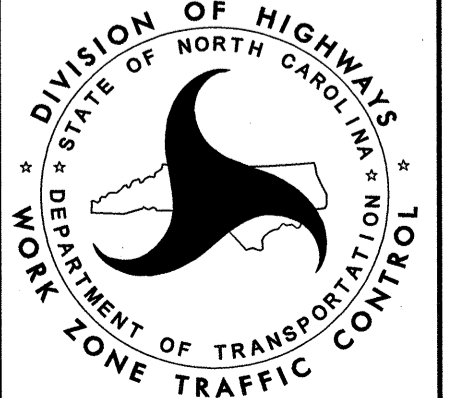
APPROVED: <i>H. A. Persiani</i> DATE: 5/20/2013			<b>TEMPORARY TRAFFIC CONTROL PHASE I DETAIL</b>
---	---	---	---

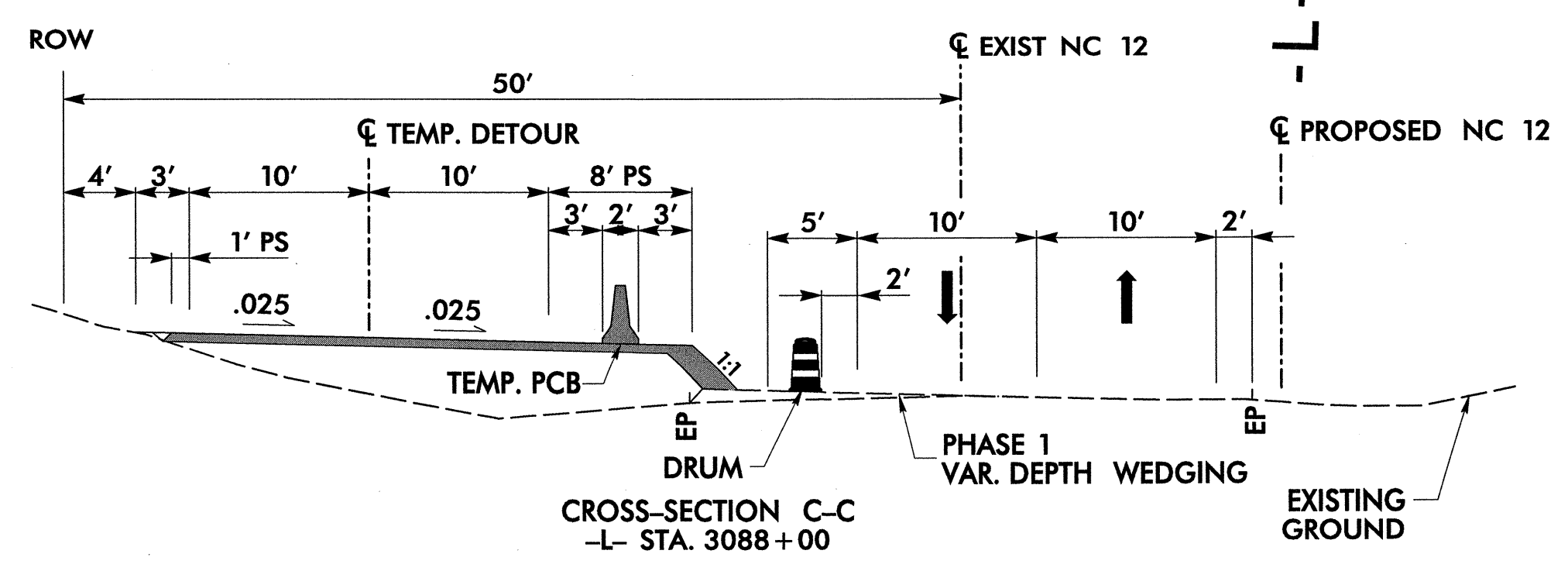
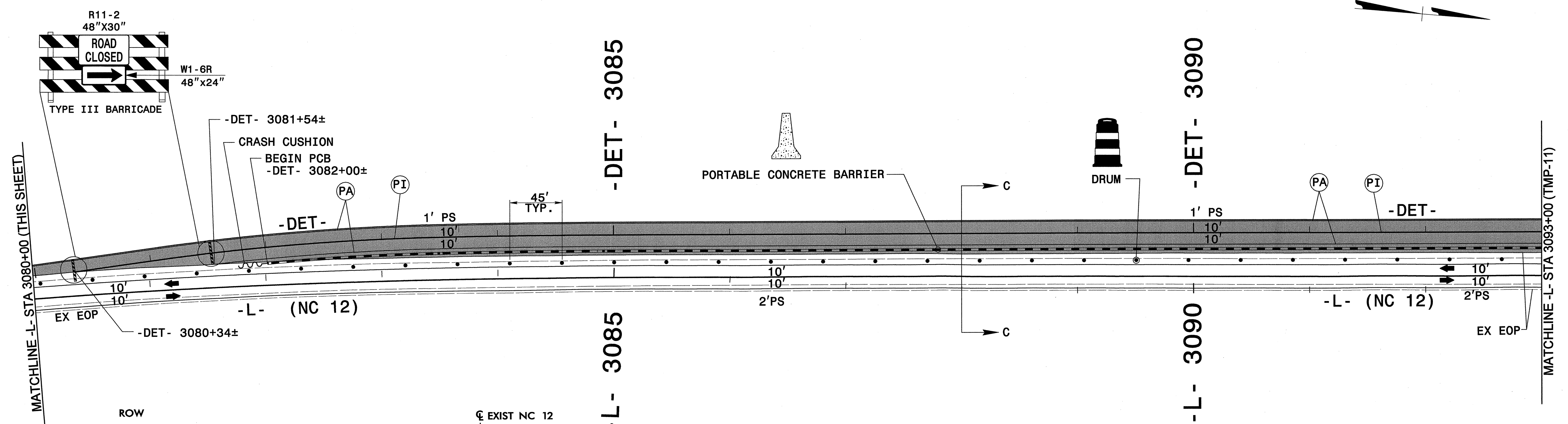
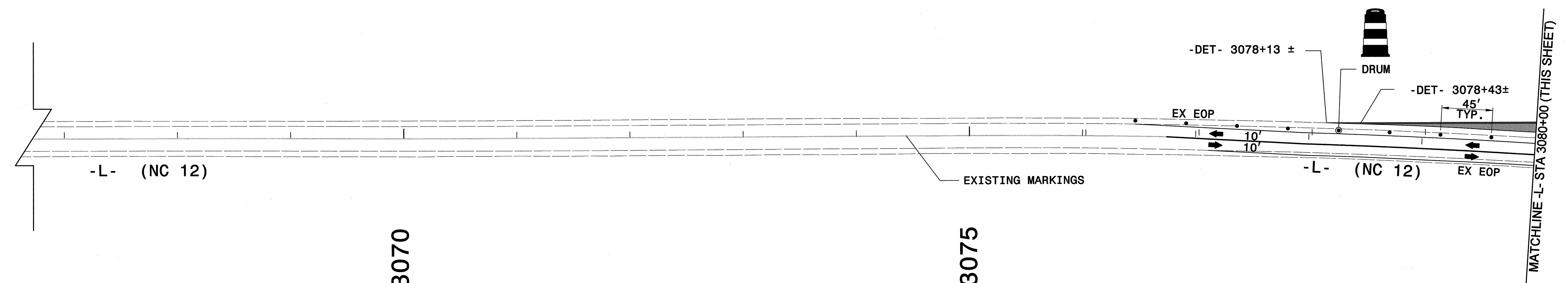

APPROVED: *[Signature]* DATE: 5/28/2013

SEAL

NORTH CAROLINA PROFESSIONAL ENGINEER  
 SEAL 021655  
 KIT A. PERSIANI

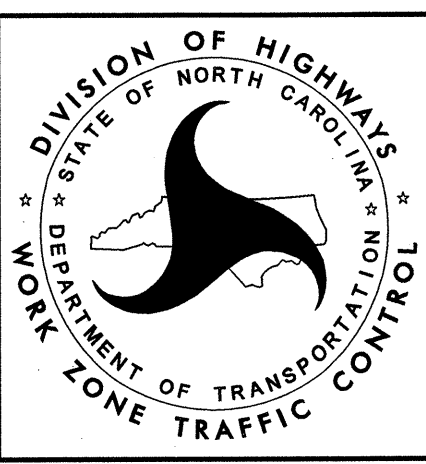

**TEMPORARY TRAFFIC CONTROL  
 PHASE II DETAIL**

5/24/2013 r:\traffic\trafficocontrol\nc\2500A\_TC\_TMP\_10.dgn

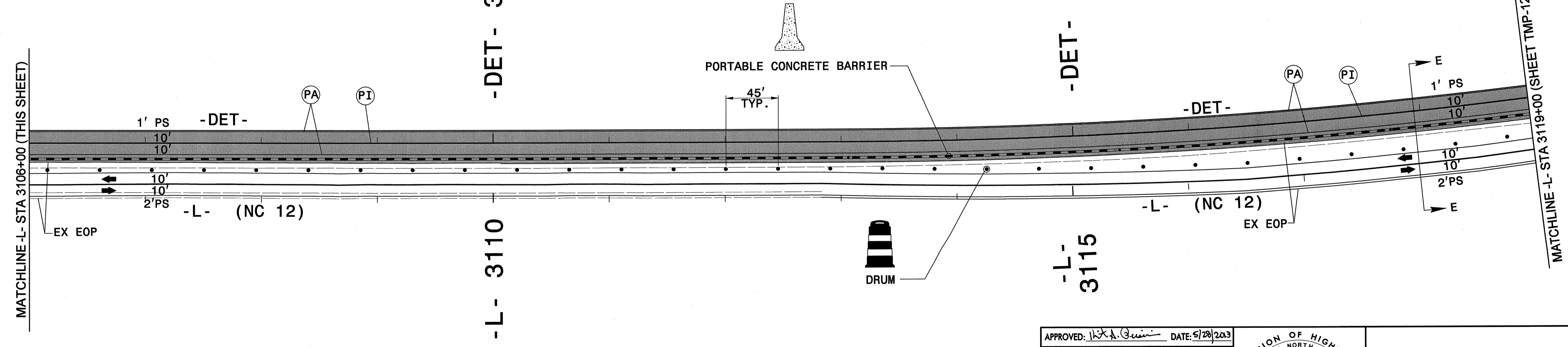
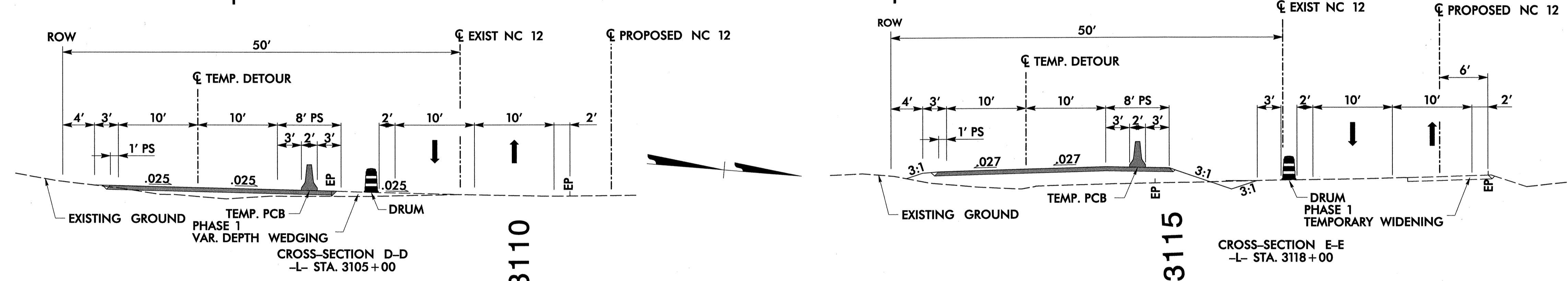
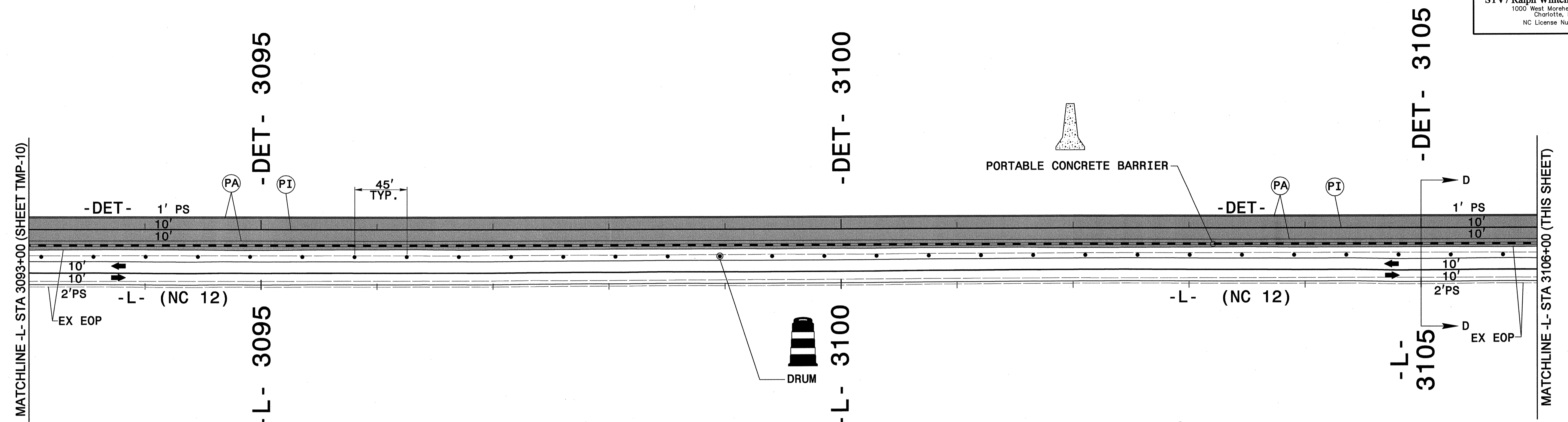

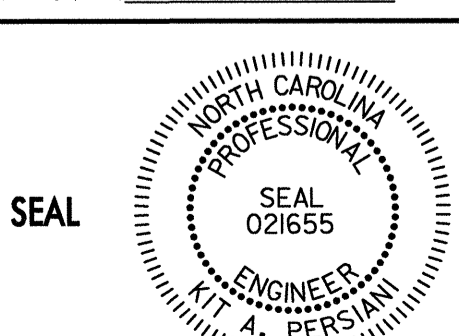
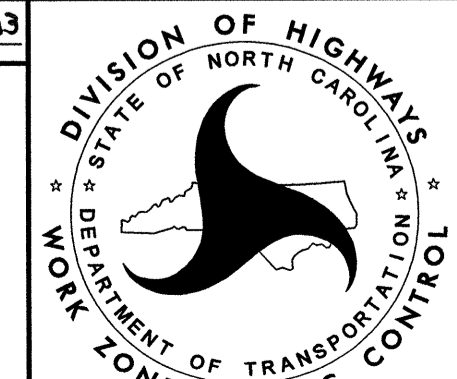

5/24/2013 r:\traffic\trafficcontrol\top\NC12PEA\_TC\_TMP\_11.dgn

APPROVED: <i>[Signature]</i> DATE: 5/28/2013			<b>TEMPORARY TRAFFIC CONTROL PHASE II DETAIL</b>
--	---	---	--

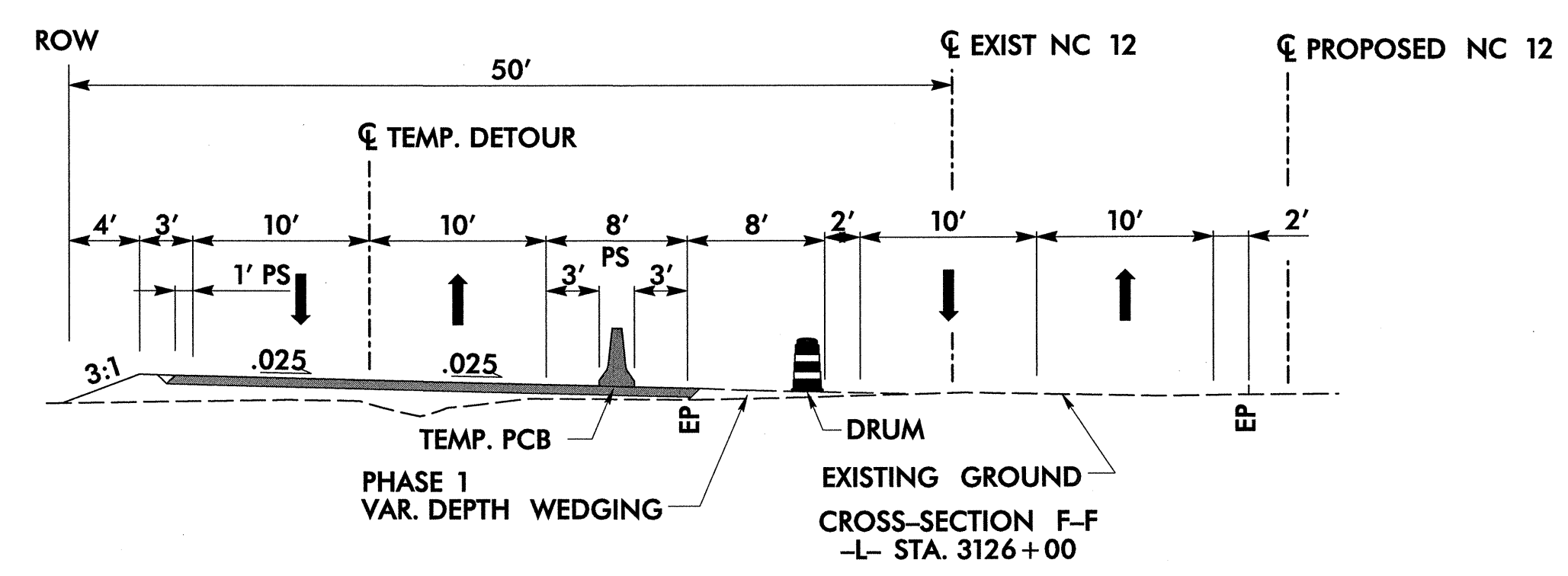
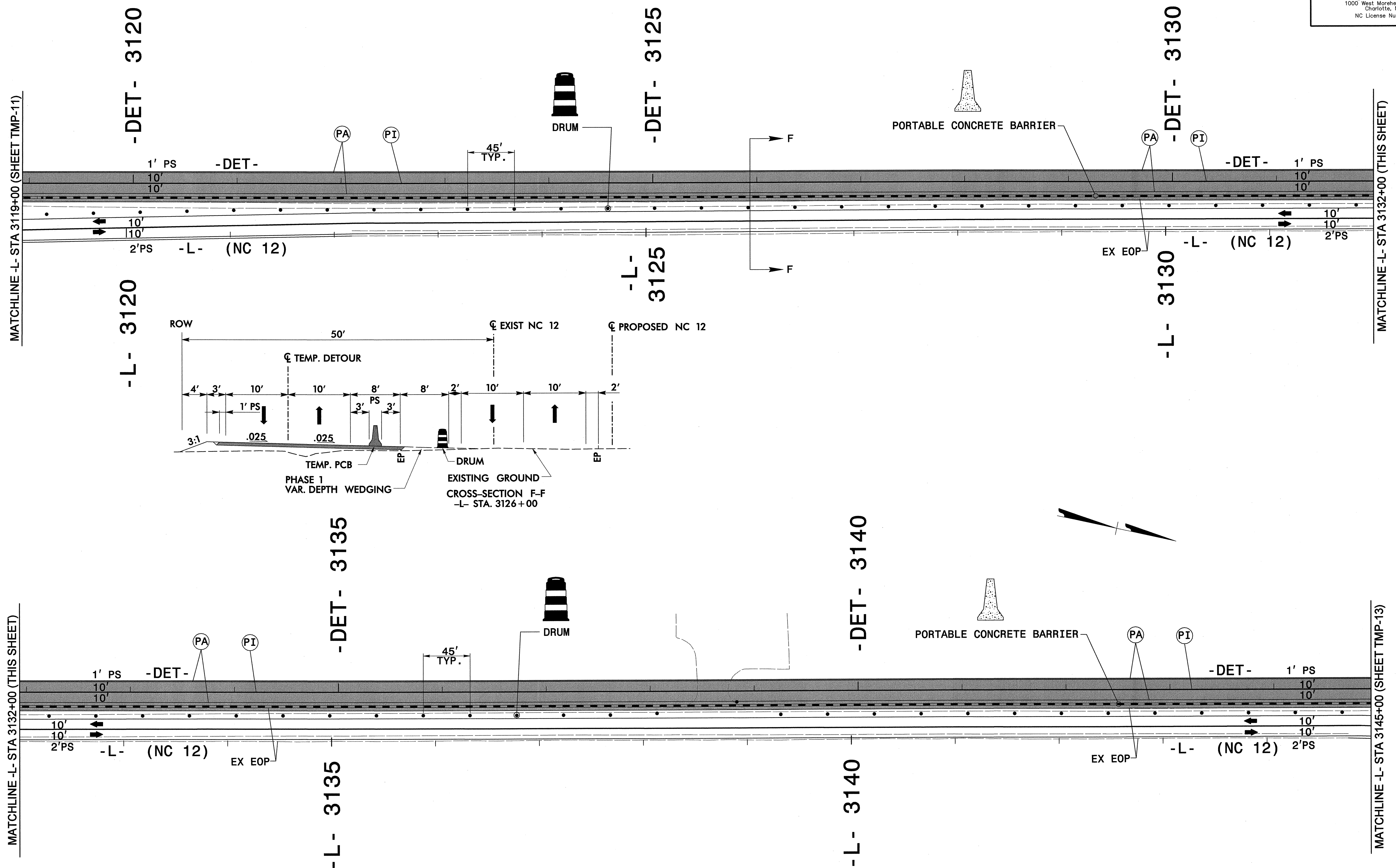



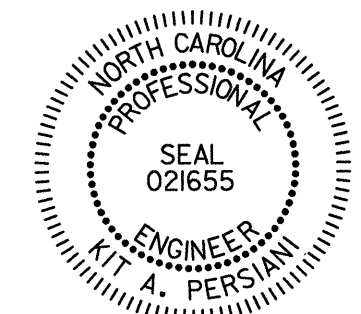

5/24/2013 r:\traffic\trafficcontrol\top\nc12\PEA\_TC\_TMP\_12.dgn

APPROVED: <i>[Signature]</i> DATE: 5/24/2013			<b>TEMPORARY TRAFFIC CONTROL          PHASE II DETAIL</b>
--	---	---	---

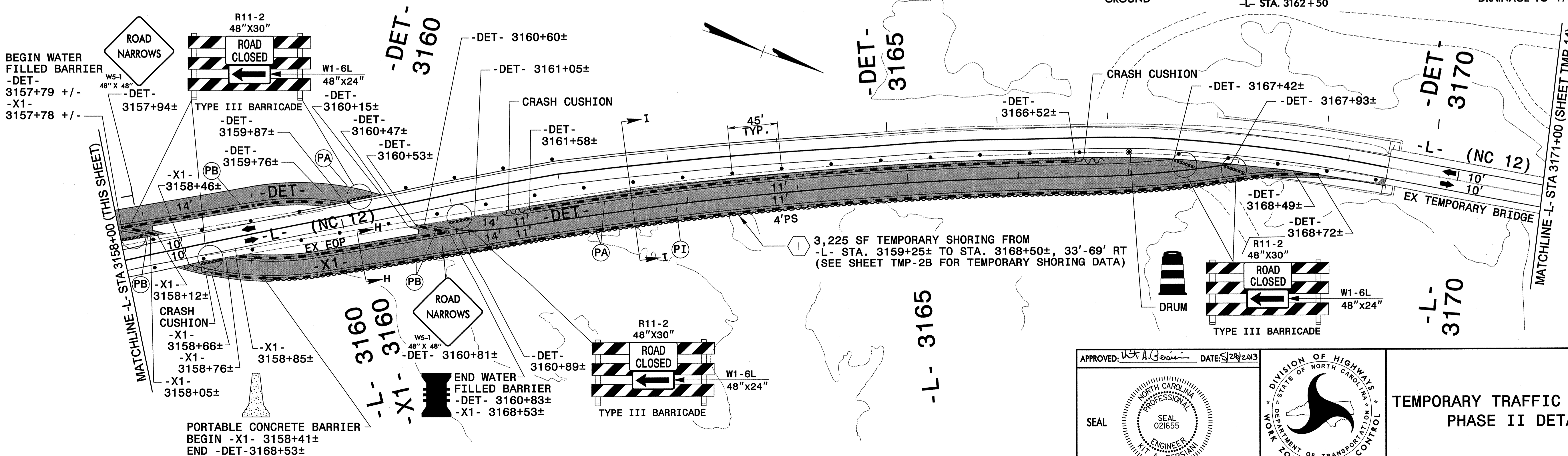
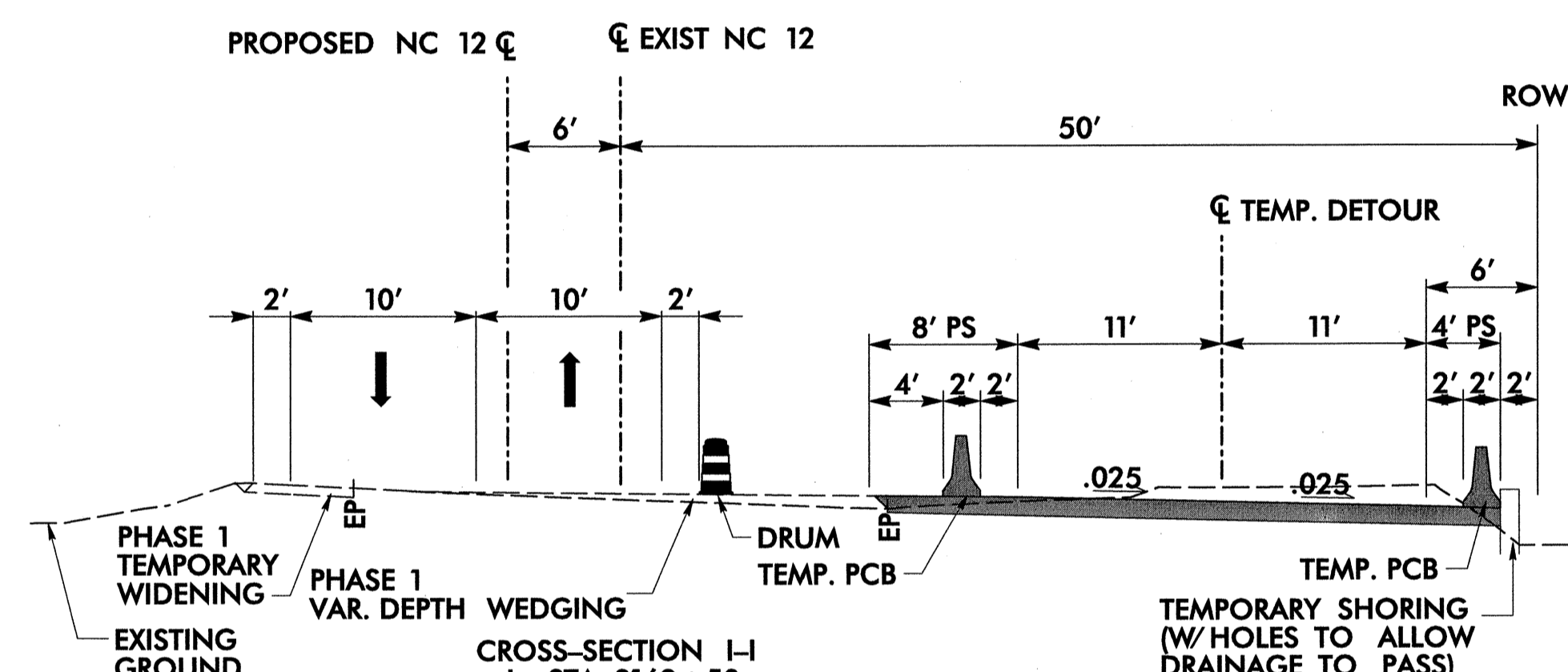
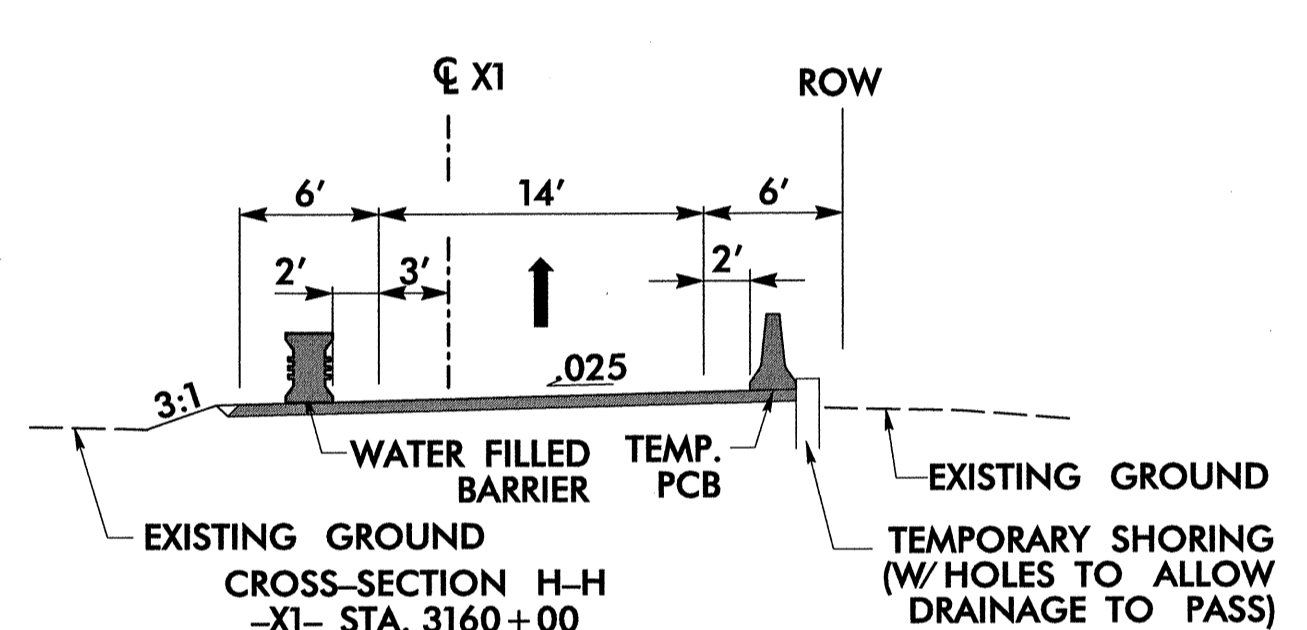
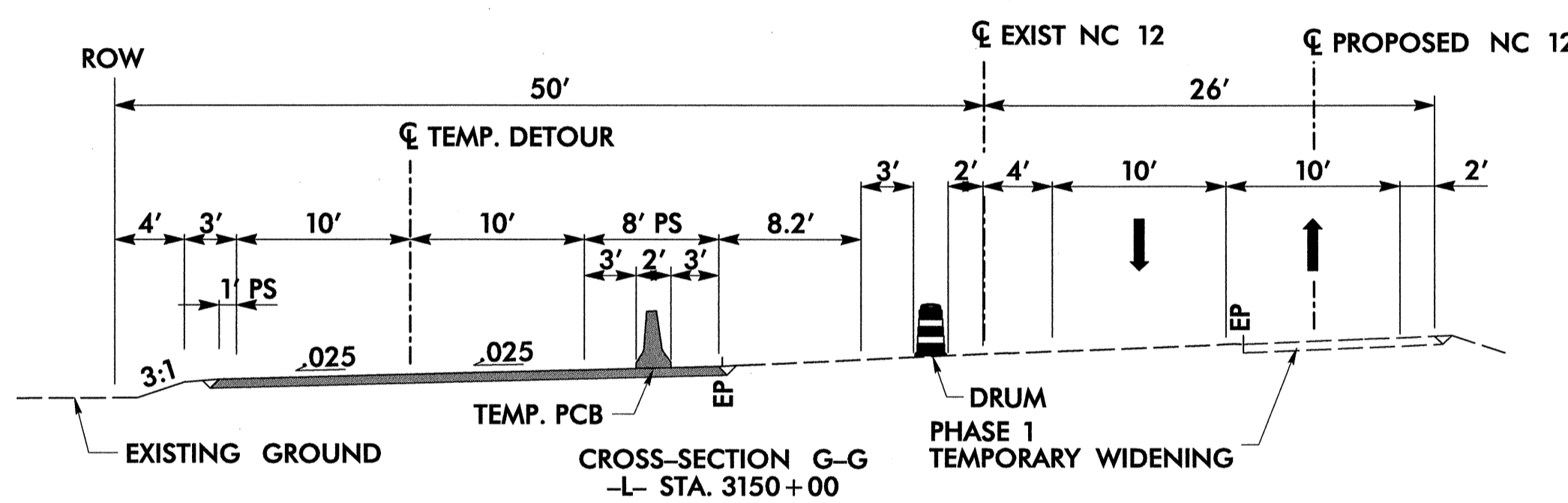
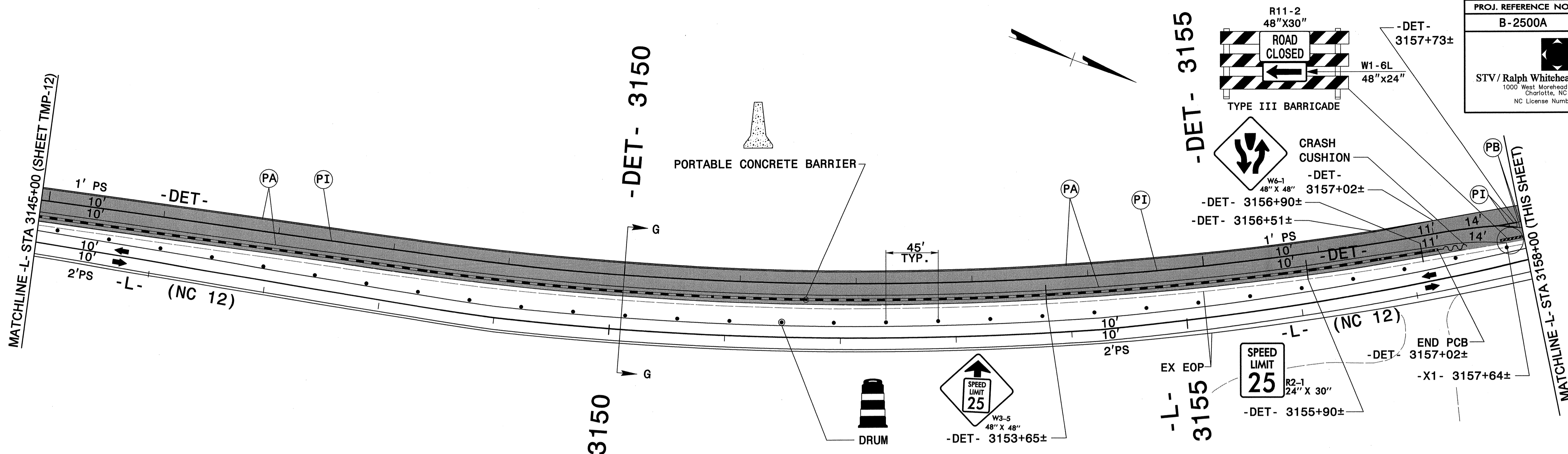



APPROVED: *[Signature]* DATE: 5/24/2013



SEAL

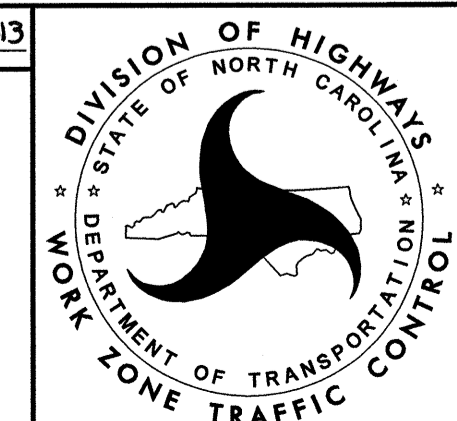

DEPARTMENT OF TRANSPORTATION  
WORK ZONE TRAFFIC CONTROL

**TEMPORARY TRAFFIC CONTROL  
PHASE II DETAIL**

5/24/2013 r:\traffic\trafficcontrol\nc12\PEA\_TC\_TMP\_13.dgn



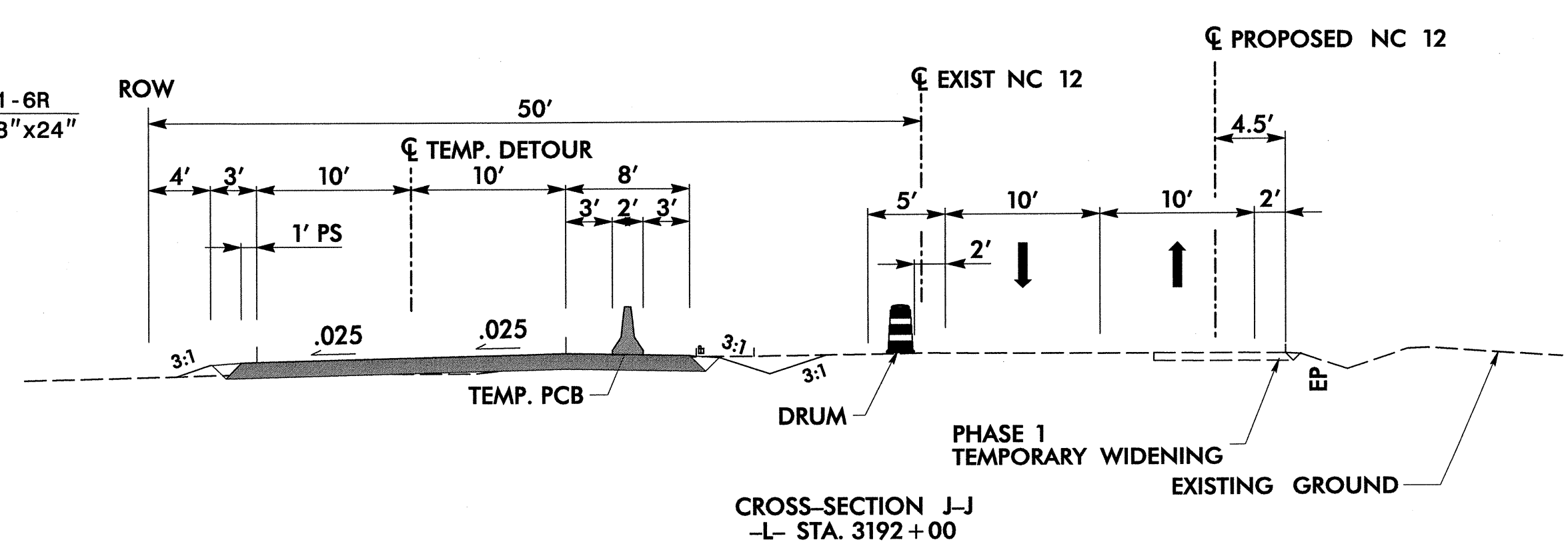
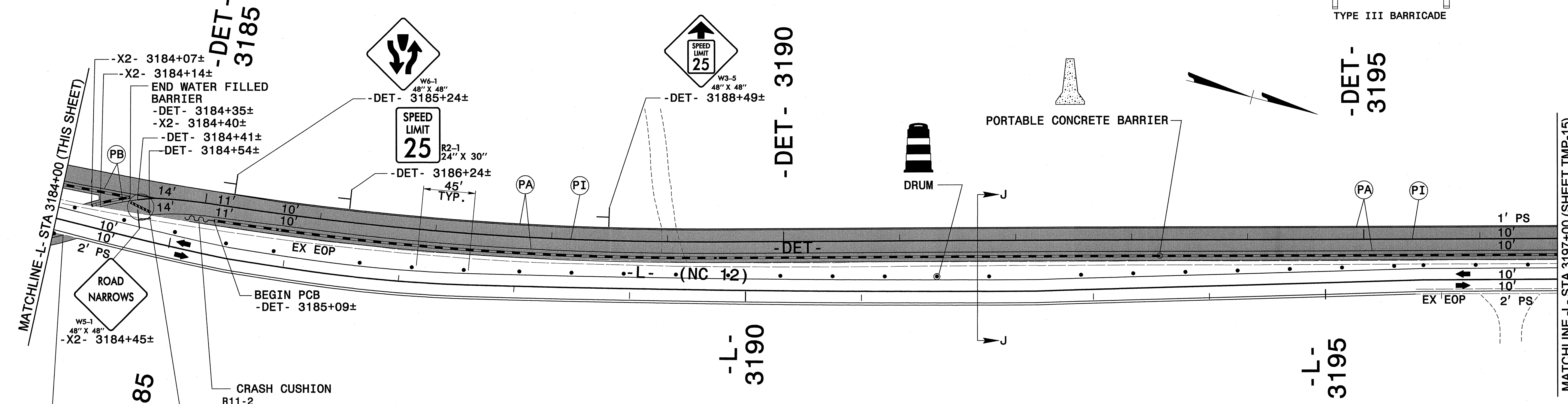
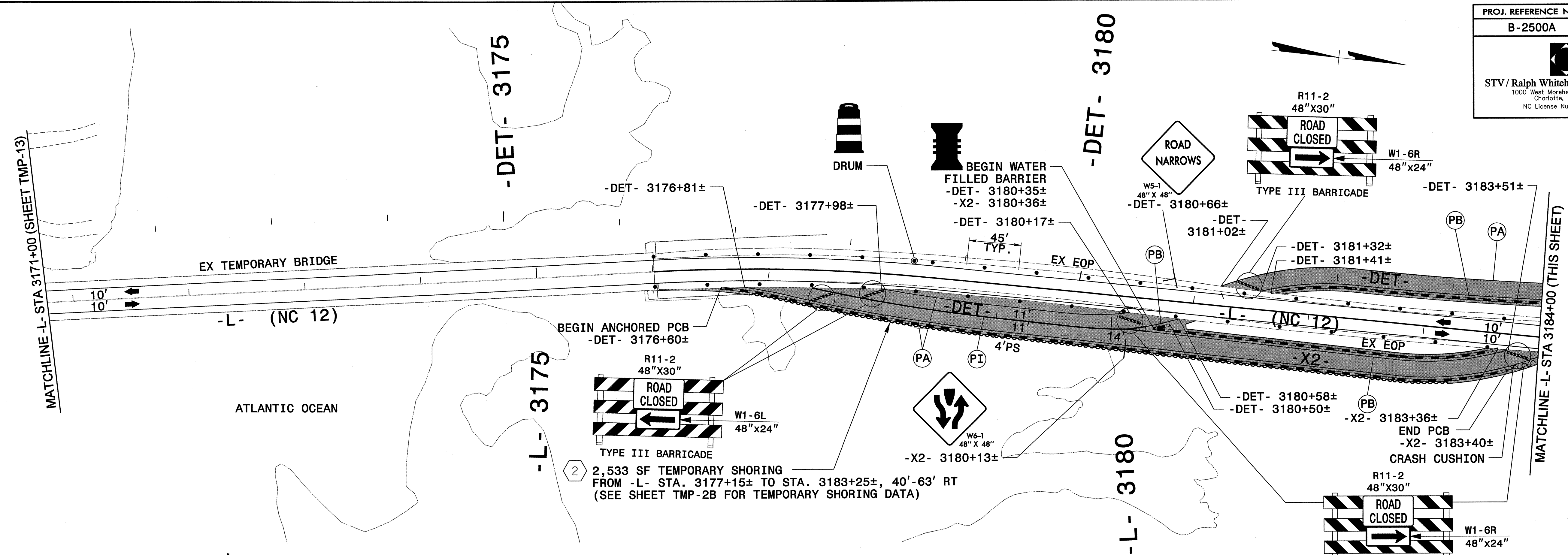

APPROVED: *[Signature]* DATE: 2/28/2013

SEAL

  
 NORTH CAROLINA  
 PROFESSIONAL  
 ENGINEER  
 M. A. PERSIANI

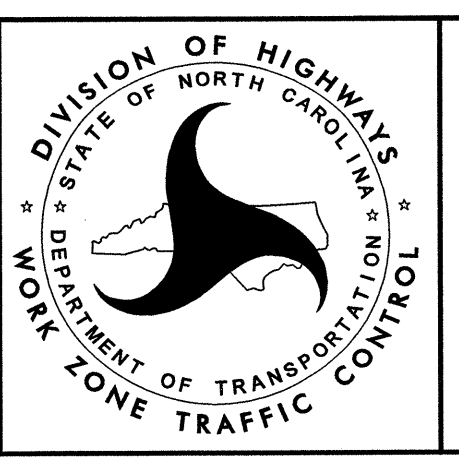



**TEMPORARY TRAFFIC CONTROL  
PHASE II DETAIL**

r:\draft\to\traffic\control\nc\2500A\_TC\_TMP\_14.dgn

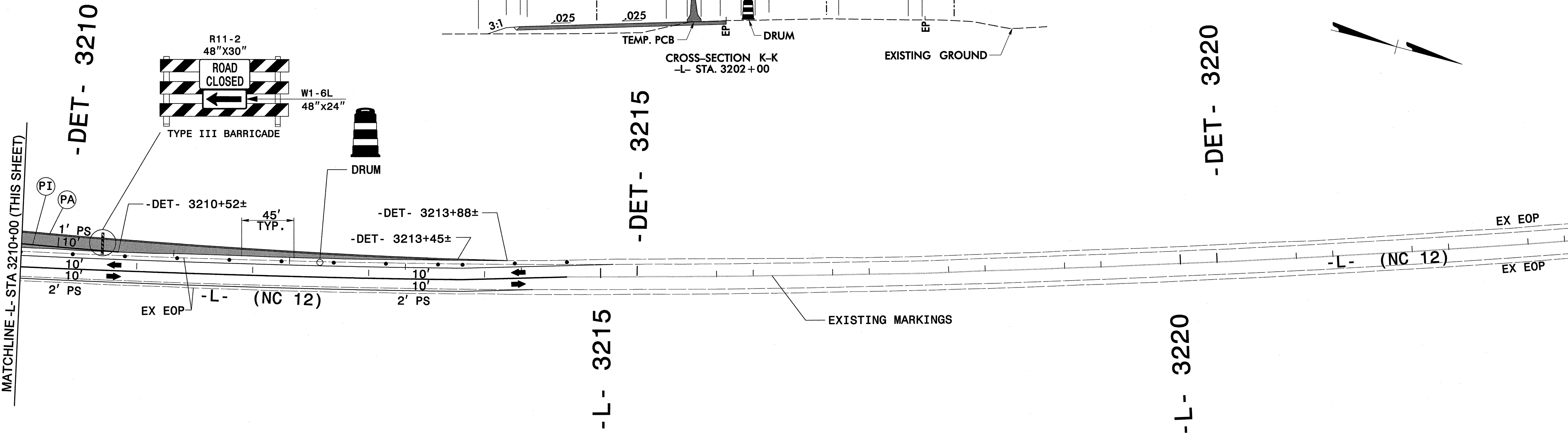
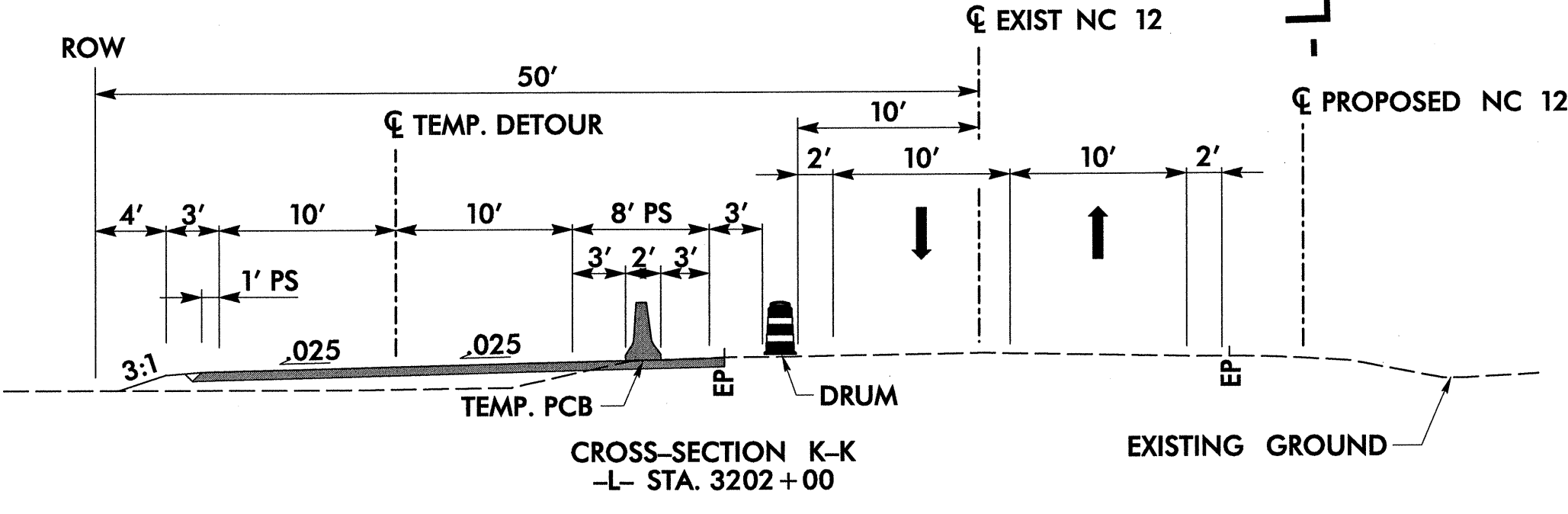
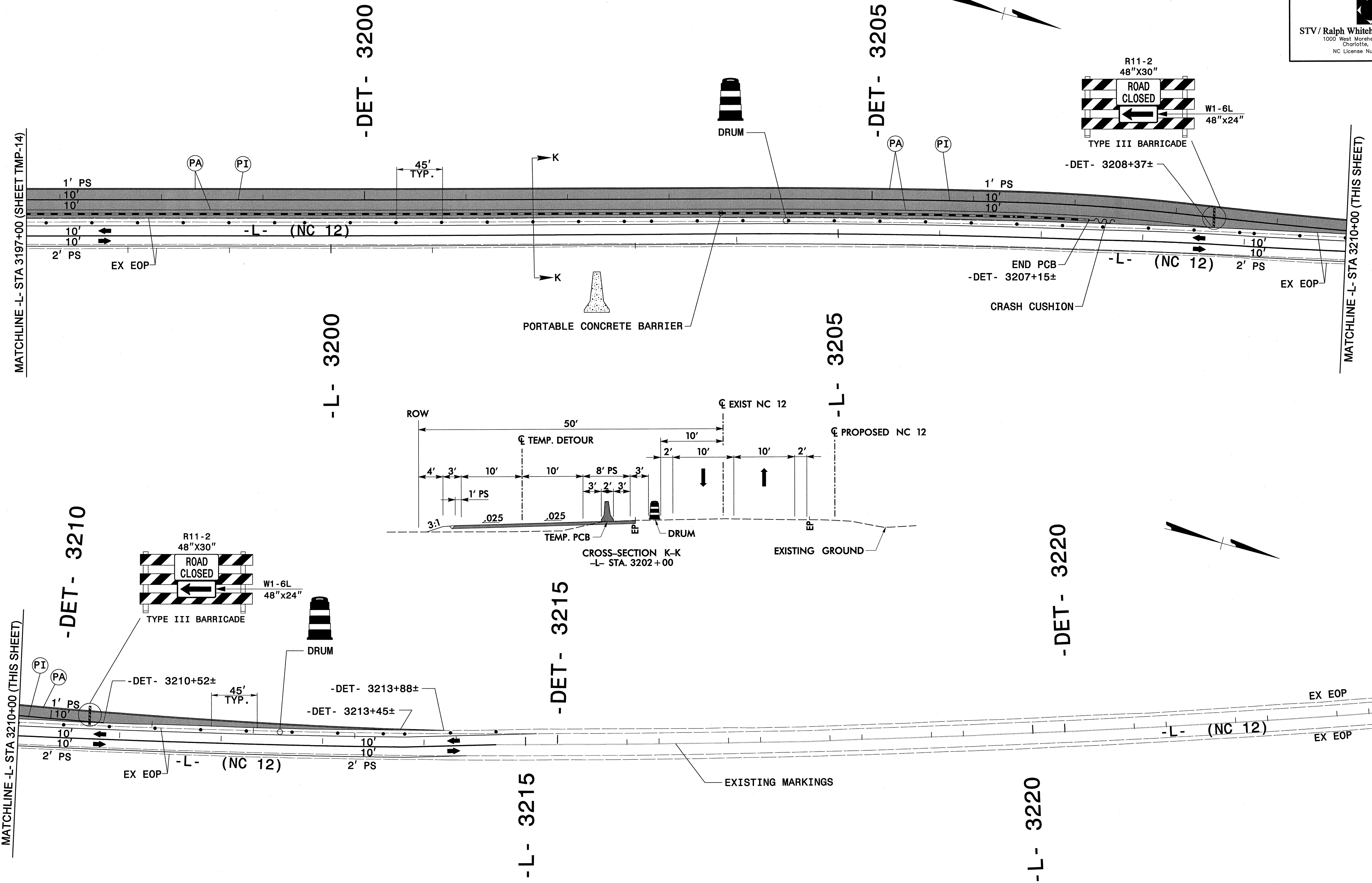



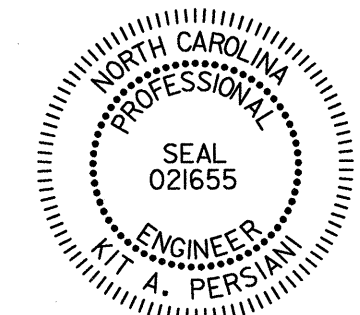

5/24/2013 r:\traffic\trafficcontrol\nc12\PEA\_TC\_TMP\_15.dgn

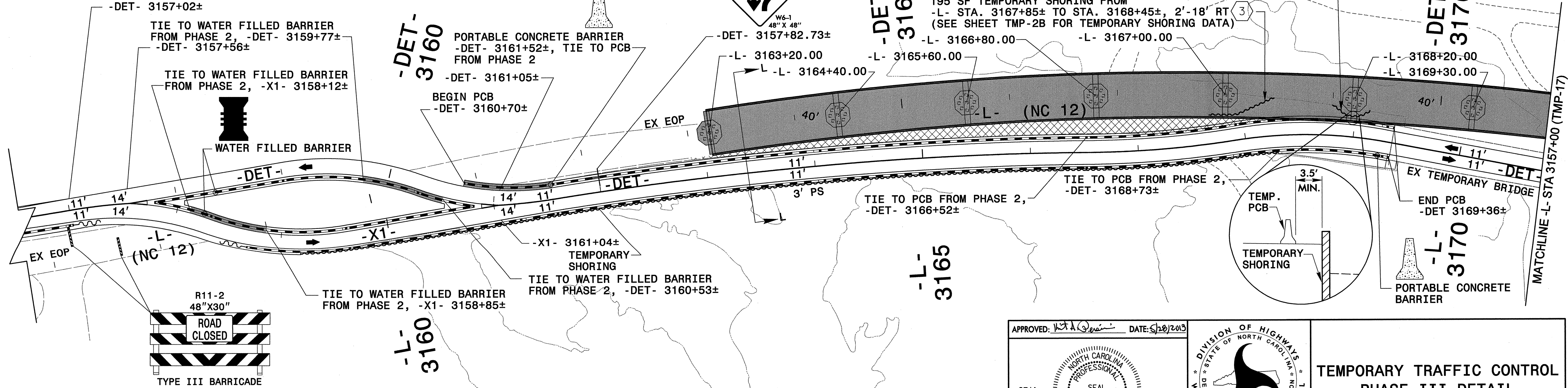
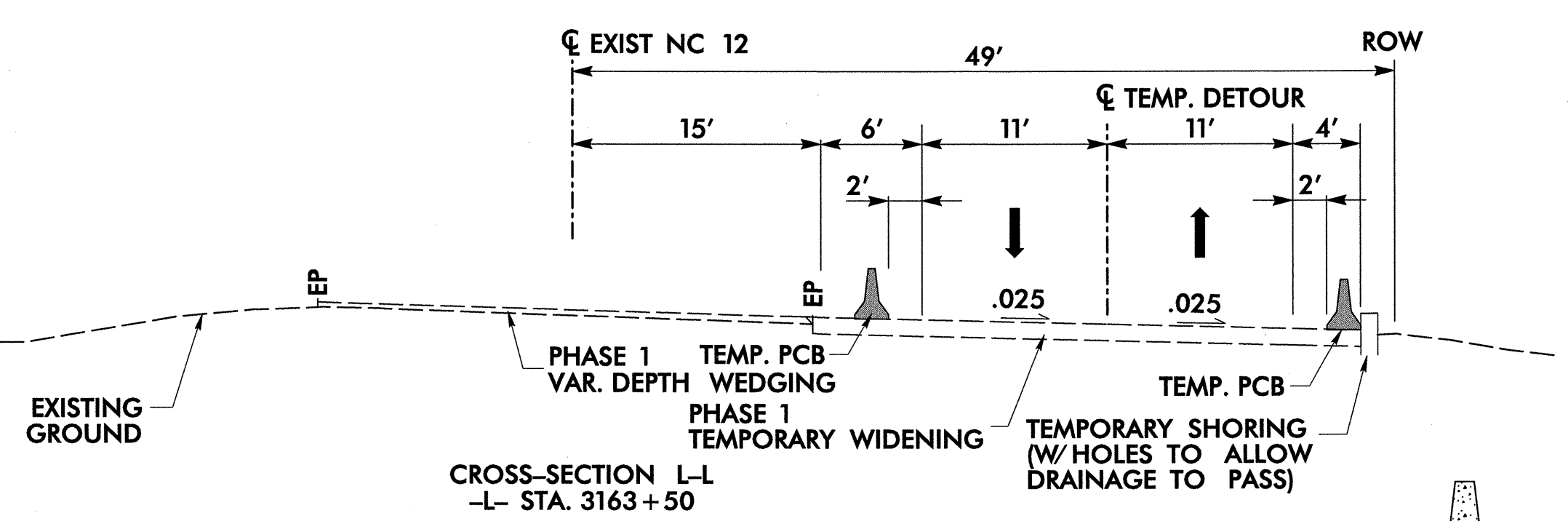
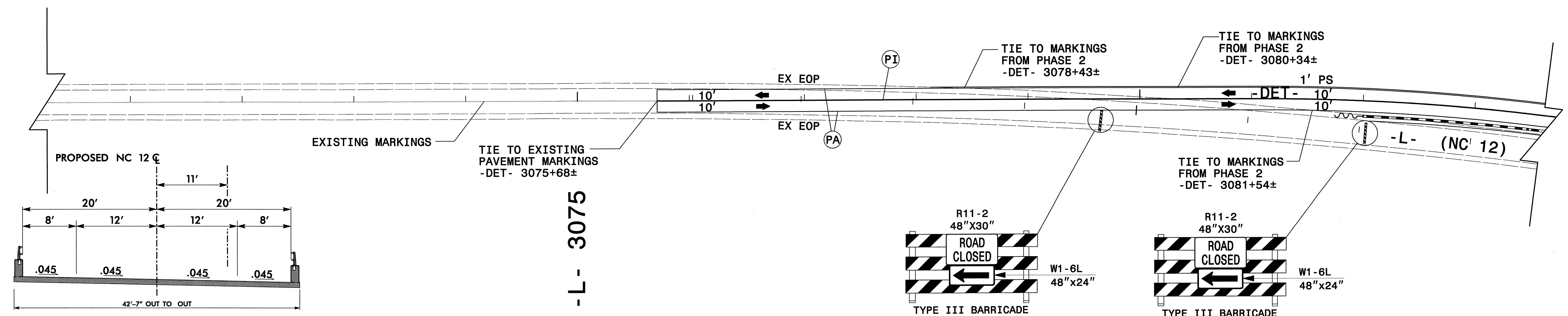
APPROVED: <i>[Signature]</i> DATE: 5/28/2013			<b>TEMPORARY TRAFFIC CONTROL PHASE II DETAIL</b>
--	---	---	--

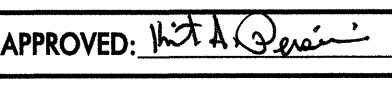

5/24/2013  
 r:\traffic\trafficcontrol\nc\2500A\TC\_TMP\_16.dgn

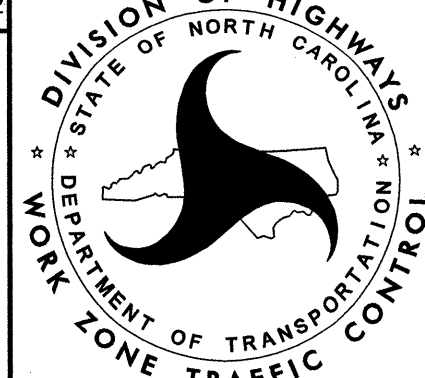
APPROVED:  DATE: 5/29/2013 	 DIVISION OF HIGHWAYS DEPARTMENT OF TRANSPORTATION WORK ZONE TRAFFIC CONTROL	<b>TEMPORARY TRAFFIC CONTROL PHASE III DETAIL</b>
--	--	---



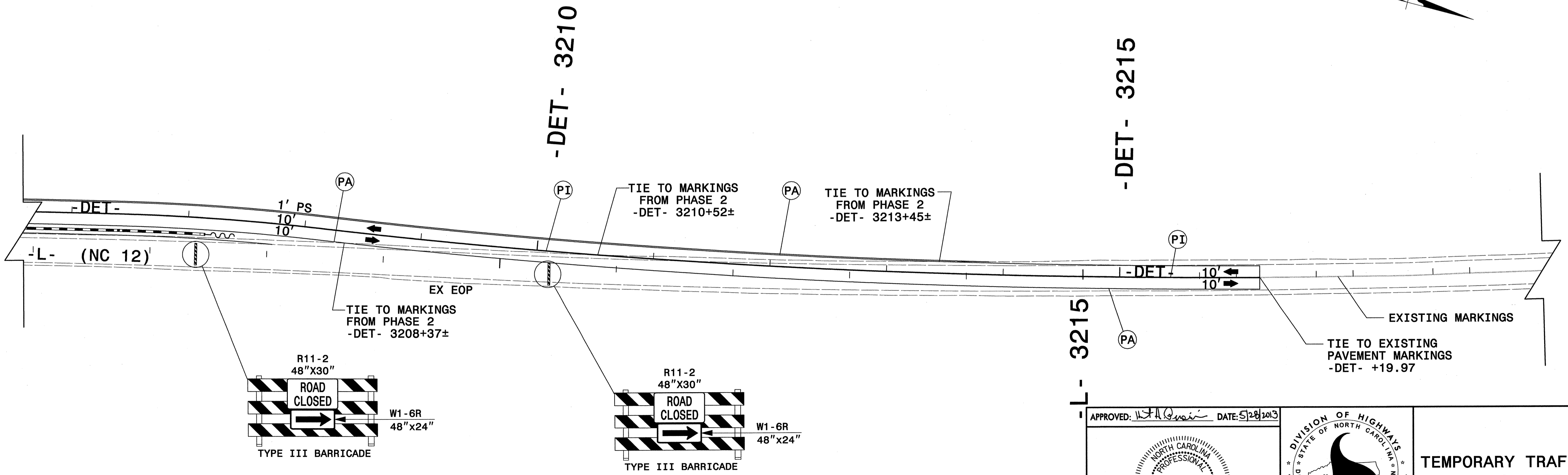
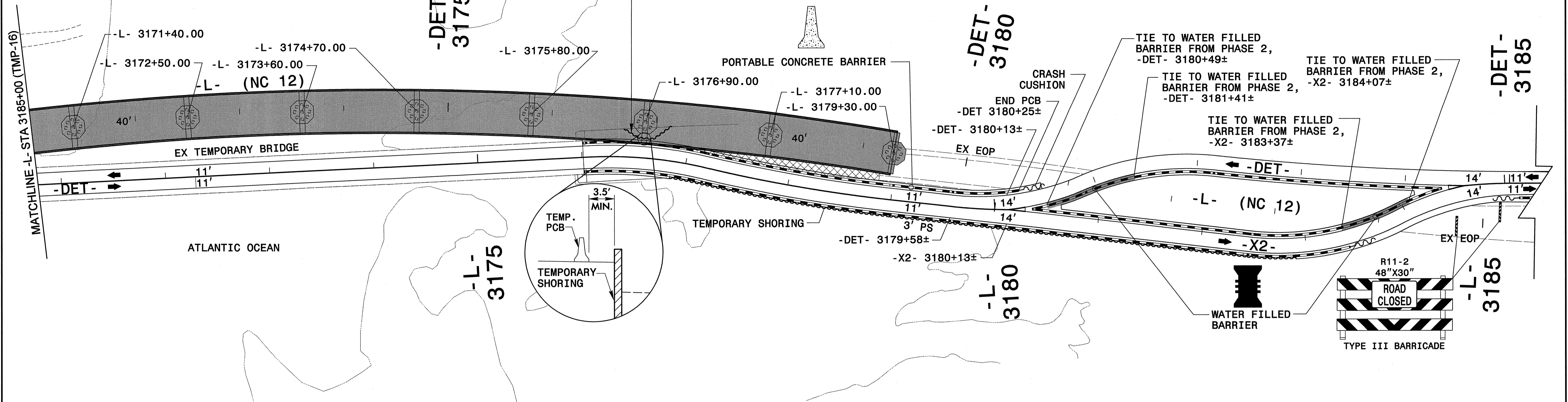

5/24/2013 r:\traffic\trafficcontrol\nc\2500A\TC\_TMP\_17.dgn

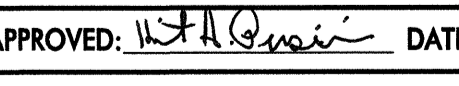
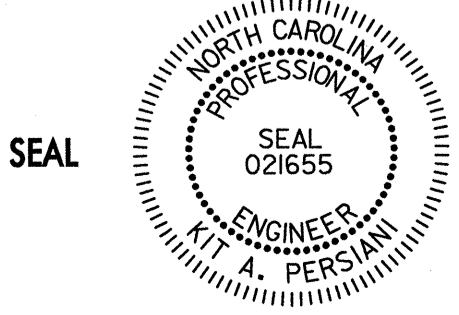
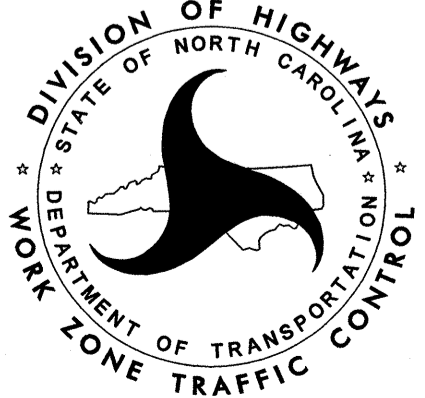
APPROVED:  DATE: 5/24/2013			<b>TEMPORARY TRAFFIC CONTROL PHASE III DETAIL</b>
SEAL			



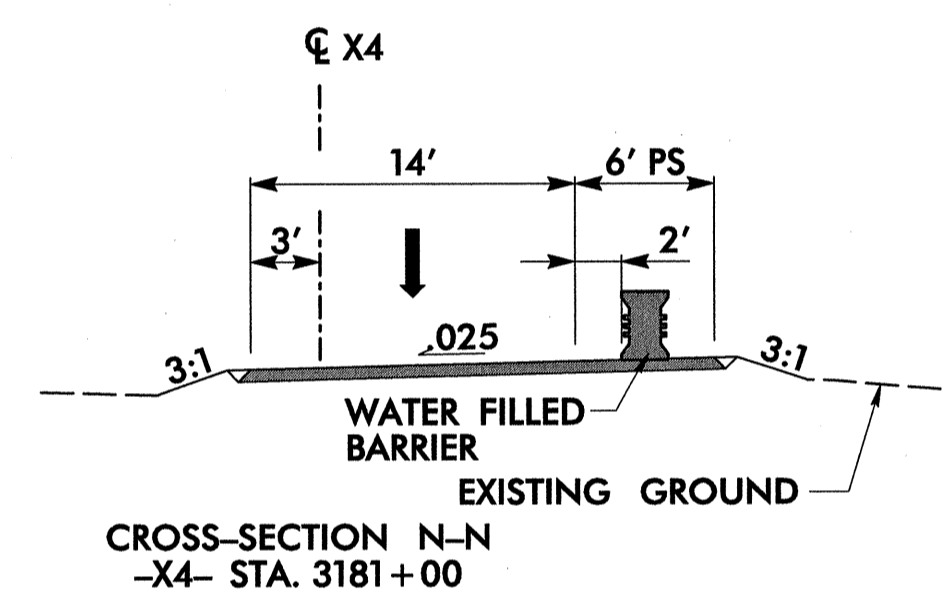
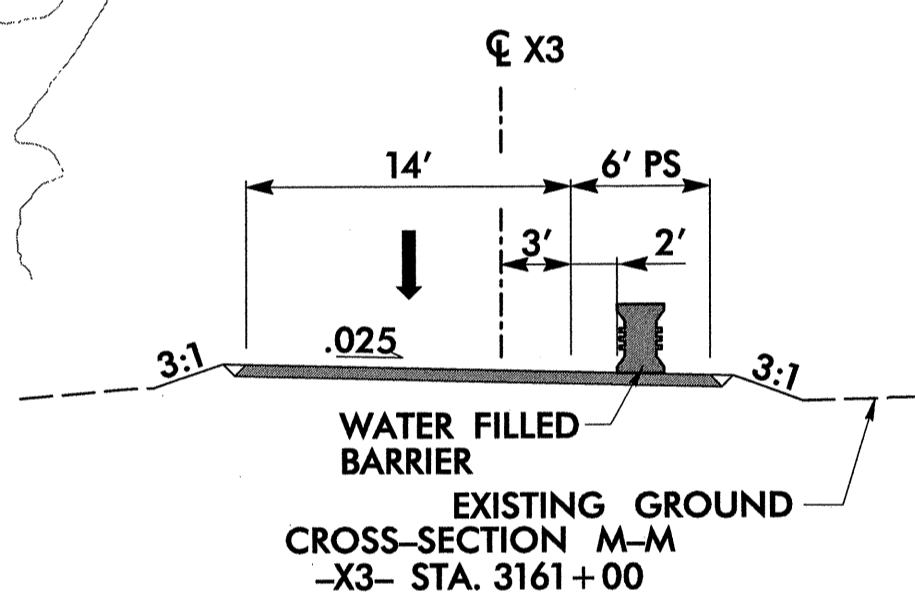
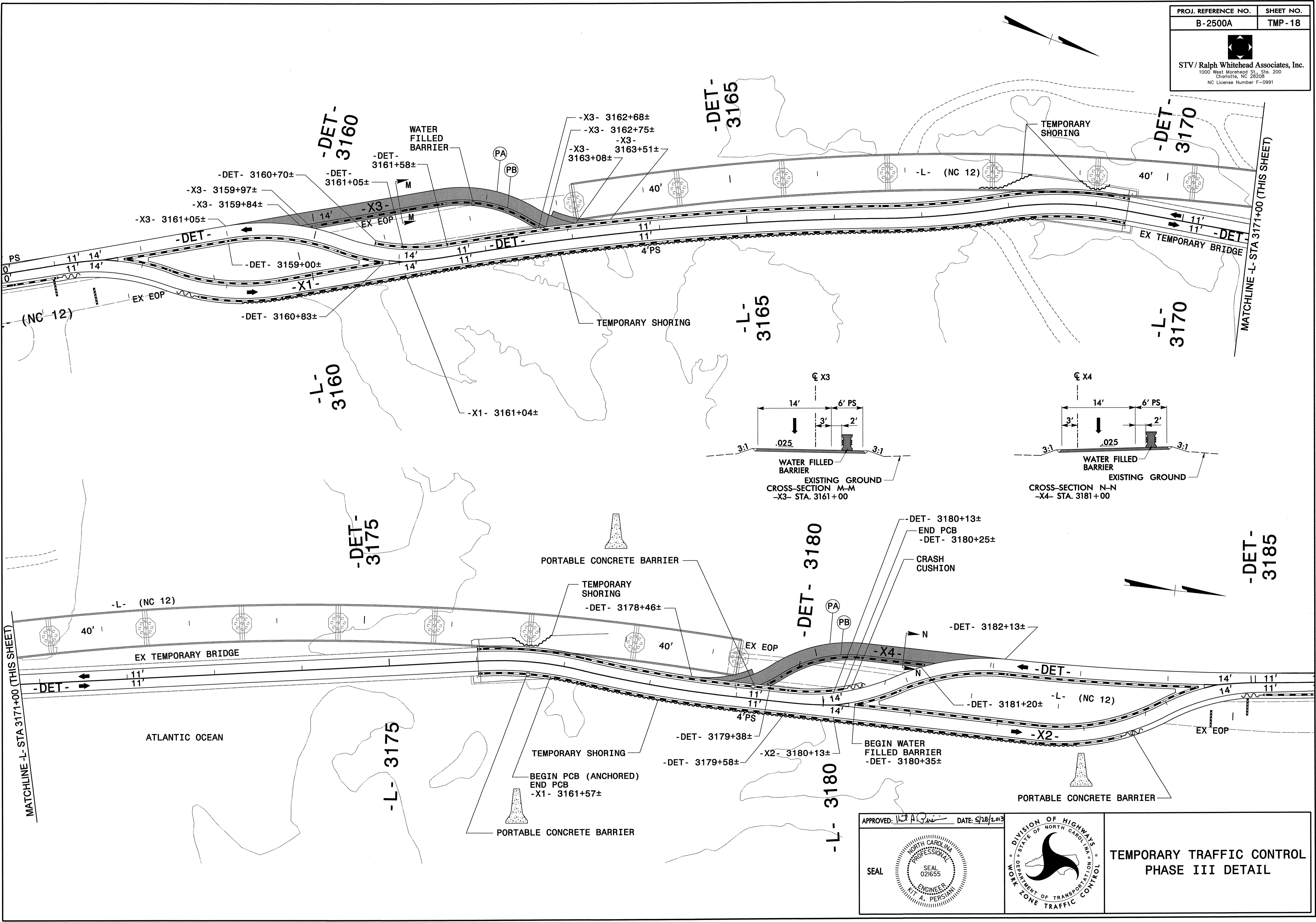

APPROVED: *[Signature]* DATE: 5/28/2013

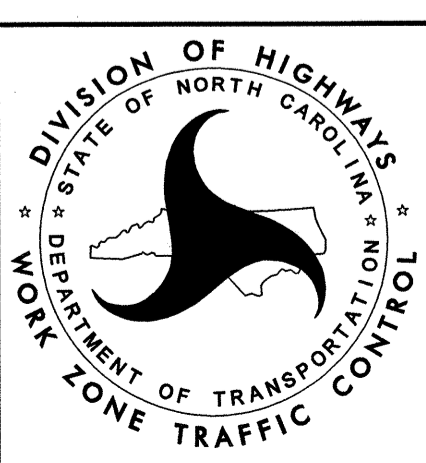
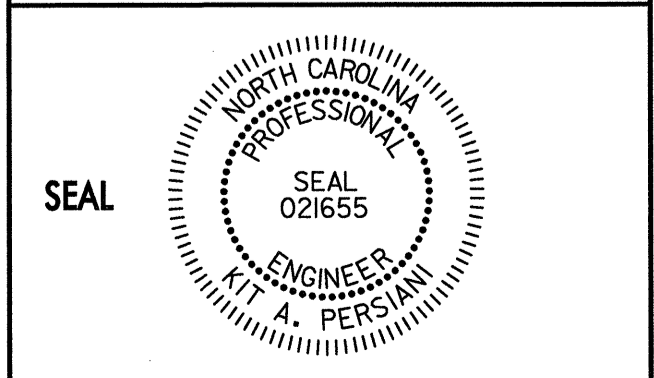

**TEMPORARY TRAFFIC CONTROL  
PHASE III DETAIL**

5/24/2013 r:\traffic\control\Nep\NCI2PEA-TC-TMP-18.dgn

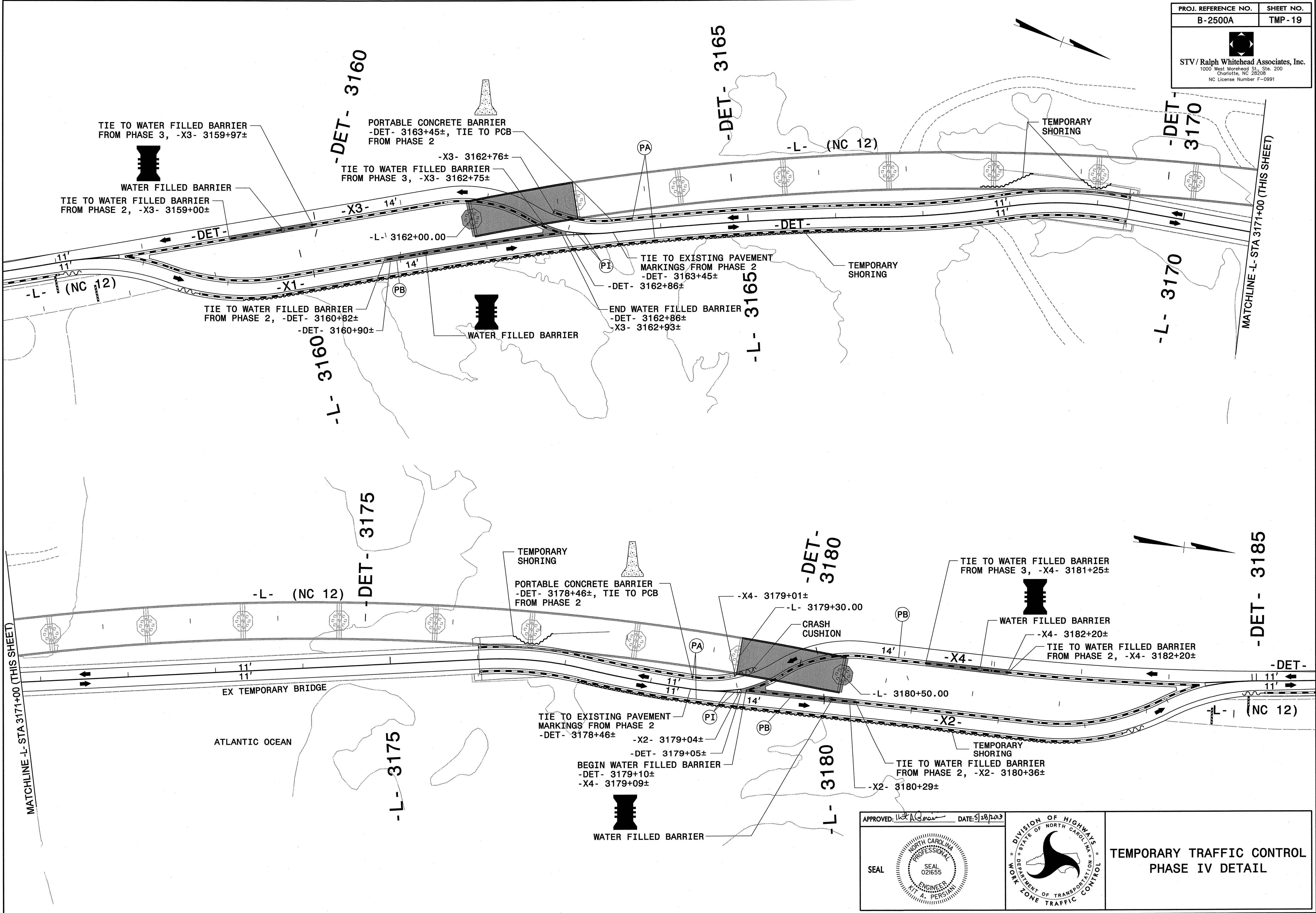

5/24/2013  
 r:\traffic\control\top\NC2PEA\_TC\_TMP\_19.dgn

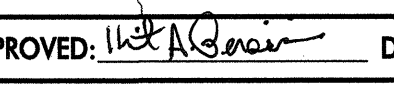
APPROVED:  DATE: 5/28/2013

SEAL

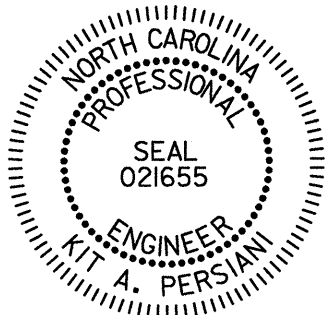
  
 NORTH CAROLINA  
 PROFESSIONAL  
 ENGINEER  
 M. A. PERSIANI  
 SEAL 021655

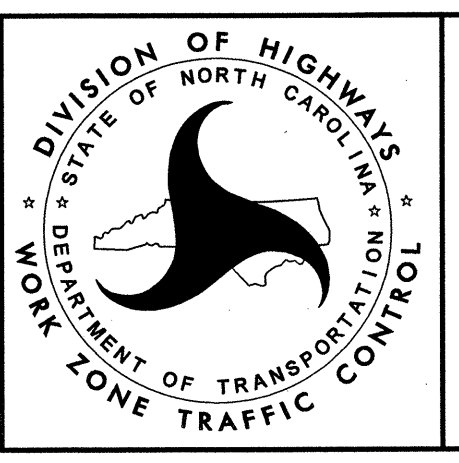

**TEMPORARY TRAFFIC CONTROL  
PHASE IV DETAIL**



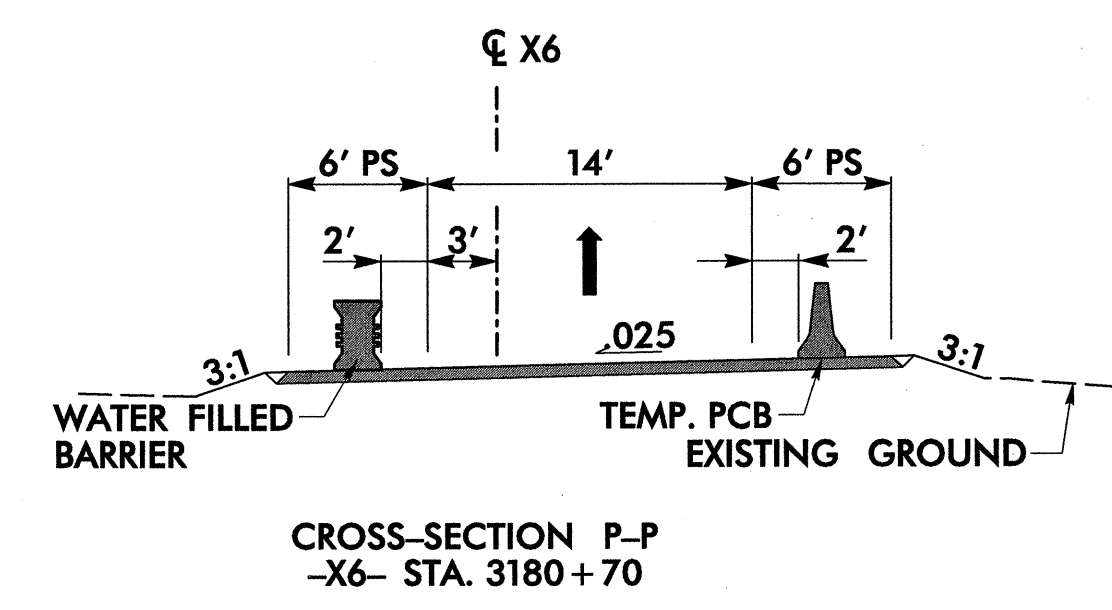
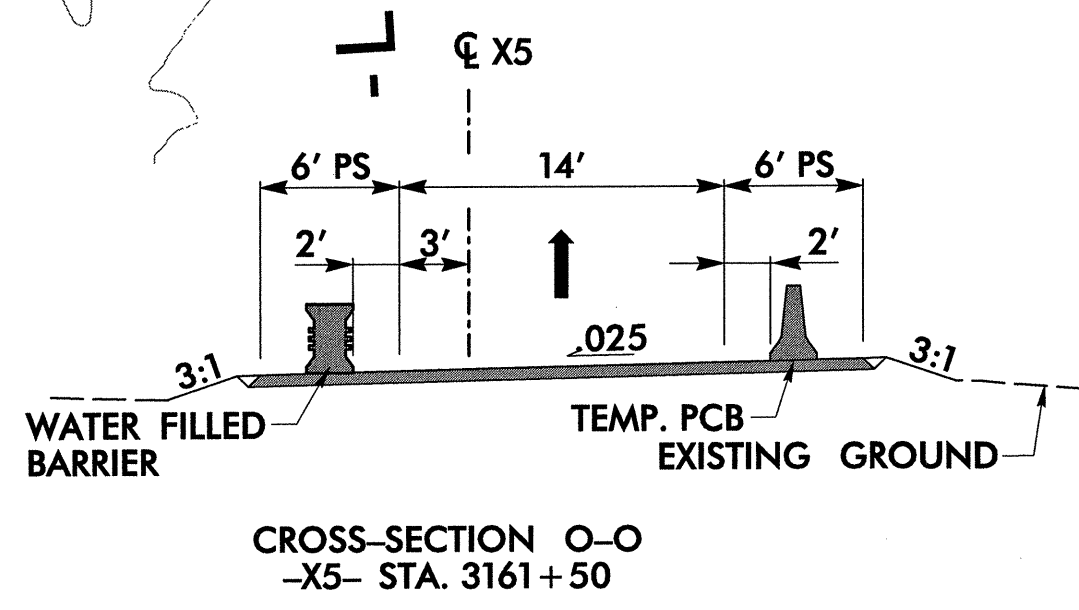
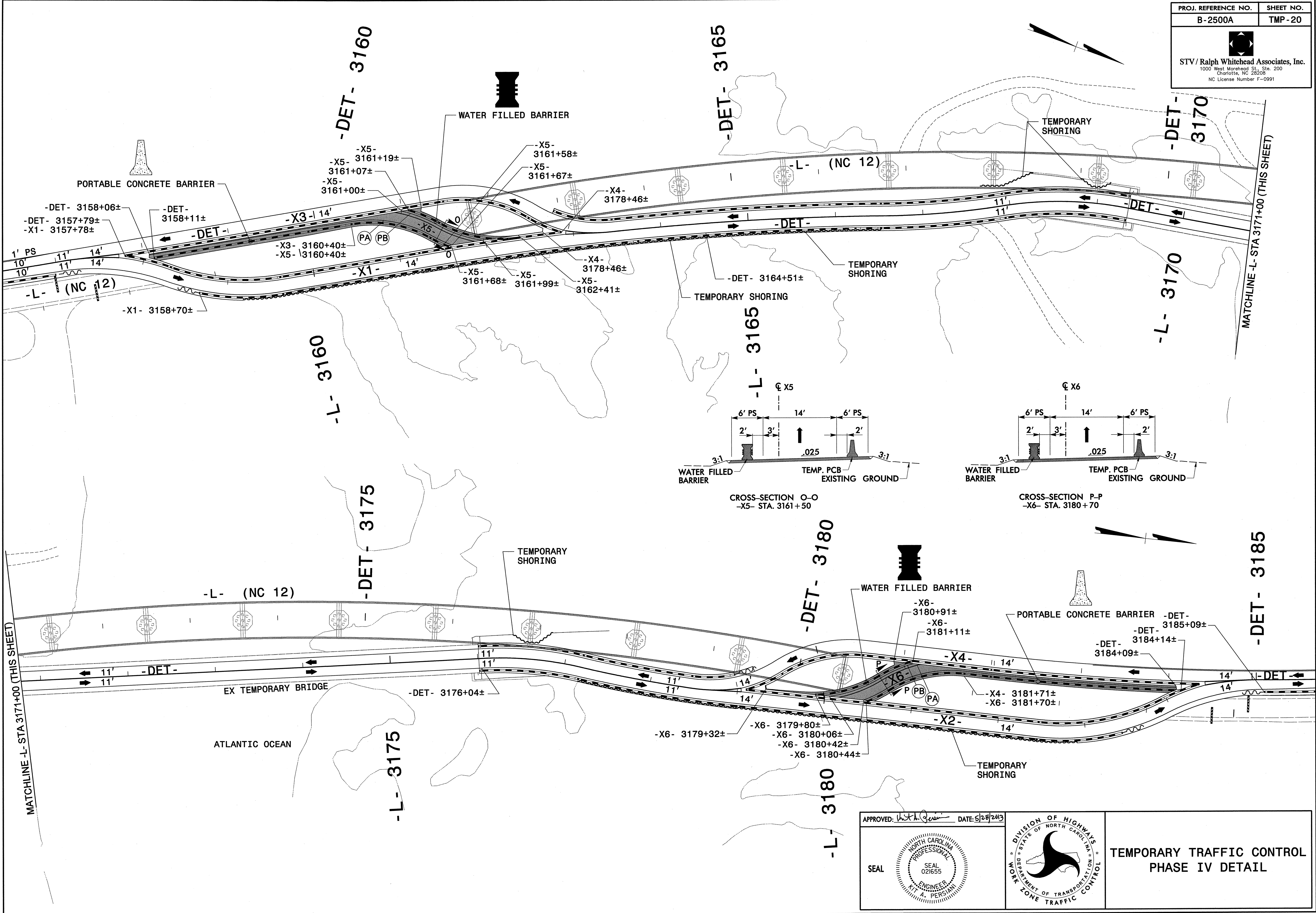

APPROVED: *[Signature]* DATE: 5/28/2013

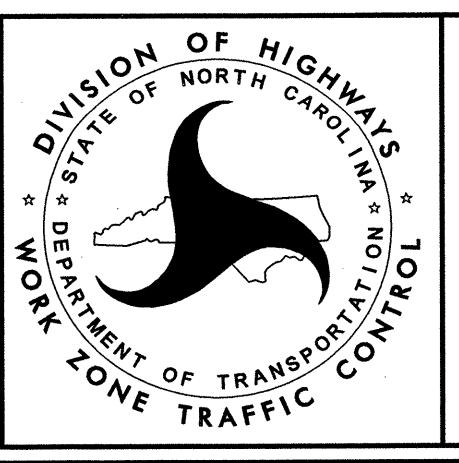
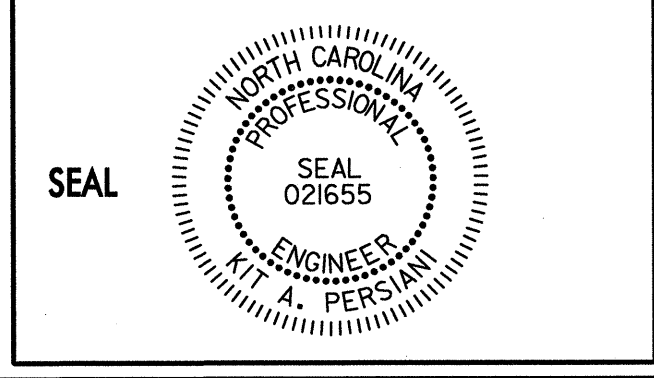

TEMPORARY TRAFFIC CONTROL  
PHASE IV DETAIL

5/24/2013 r:\traffic\trafficcontrol\nc\2PEA\_TC\_TMP\_20.dgn



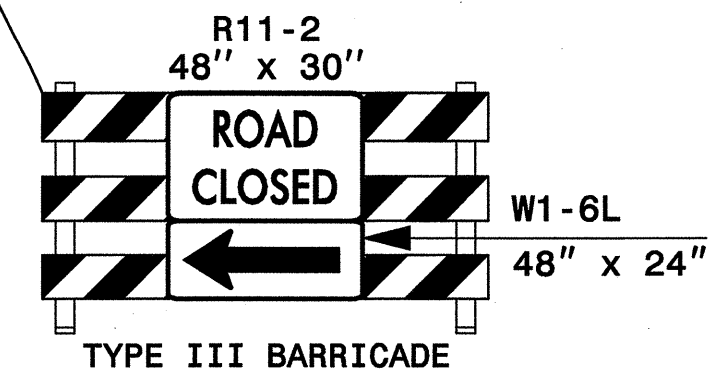
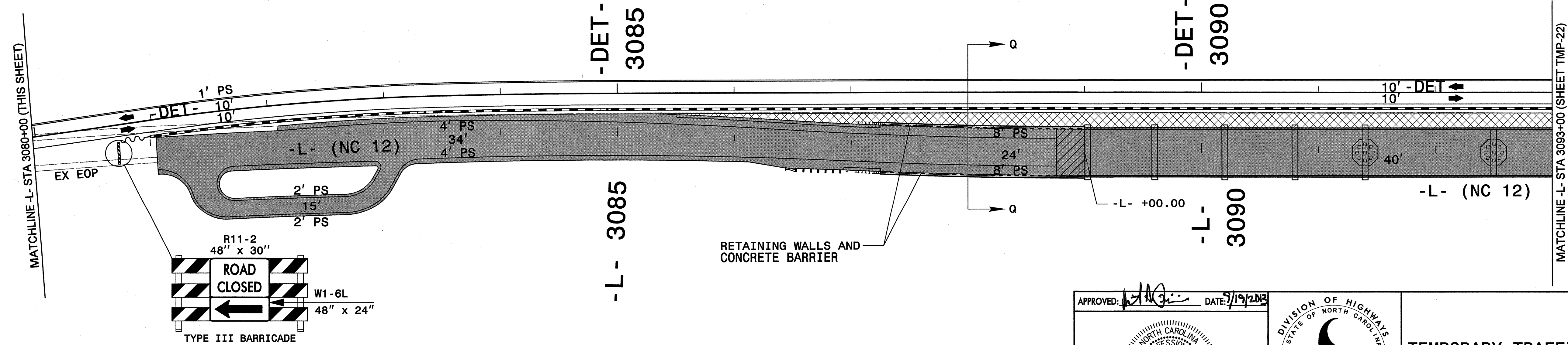
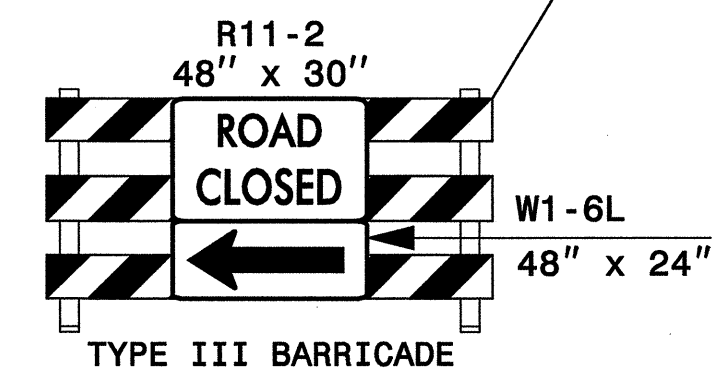
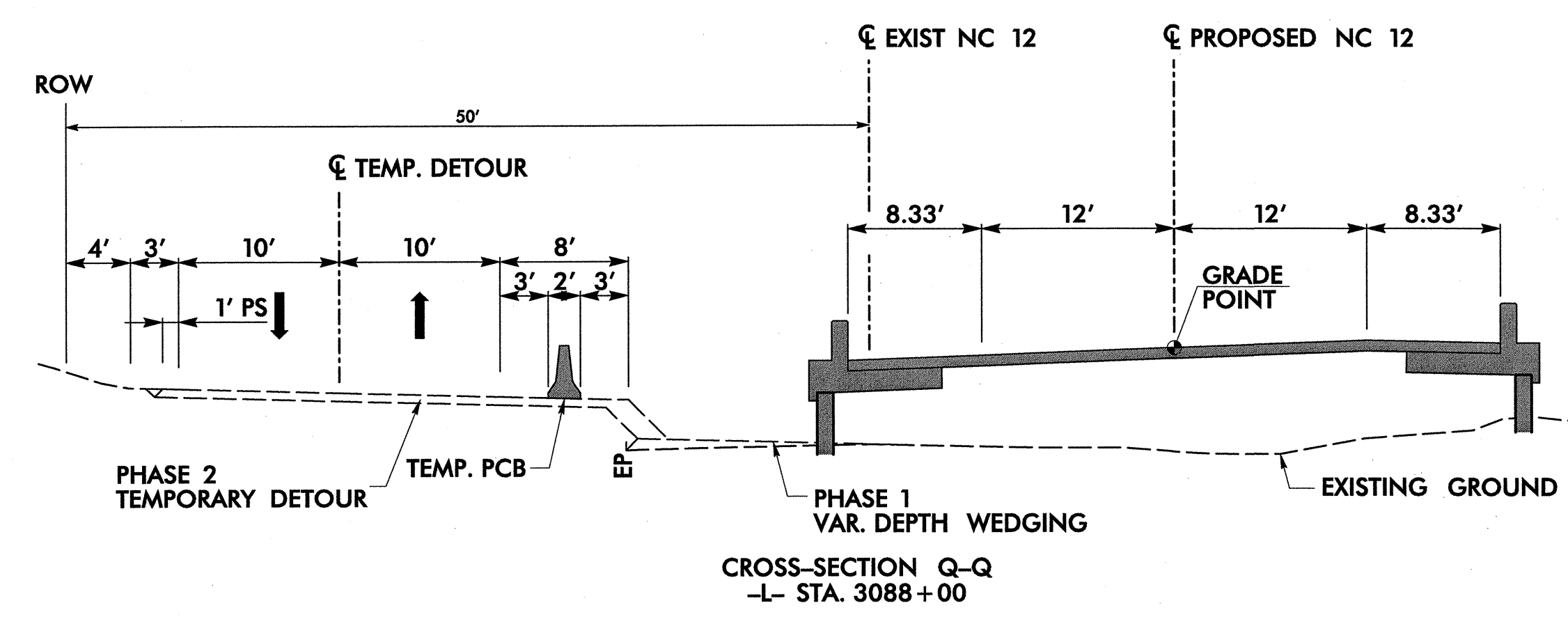
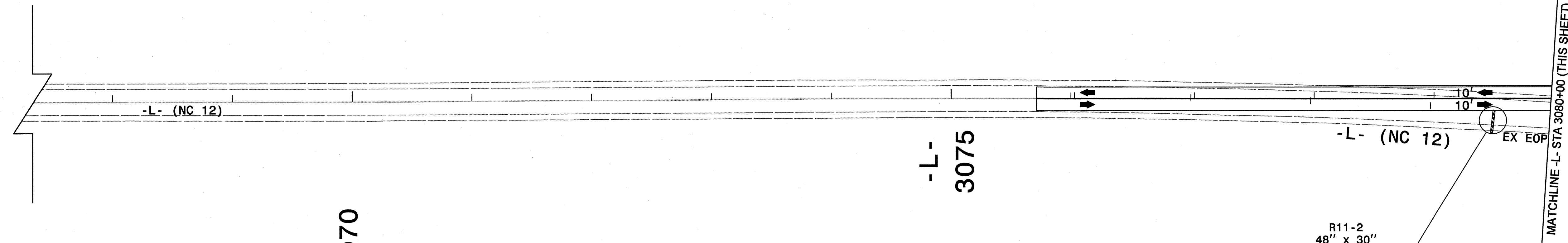

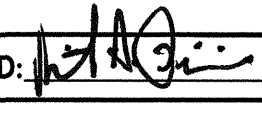
APPROVED:  DATE: 9/19/2013

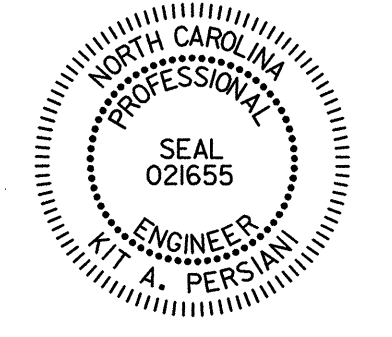
SEAL  
  
 NORTH CAROLINA PROFESSIONAL ENGINEER  
 SEAL 021655  
 P. T. PERSIANI

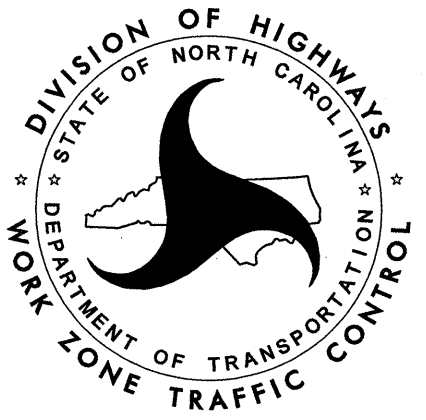

TEMPORARY TRAFFIC CONTROL  
PHASE V DETAIL

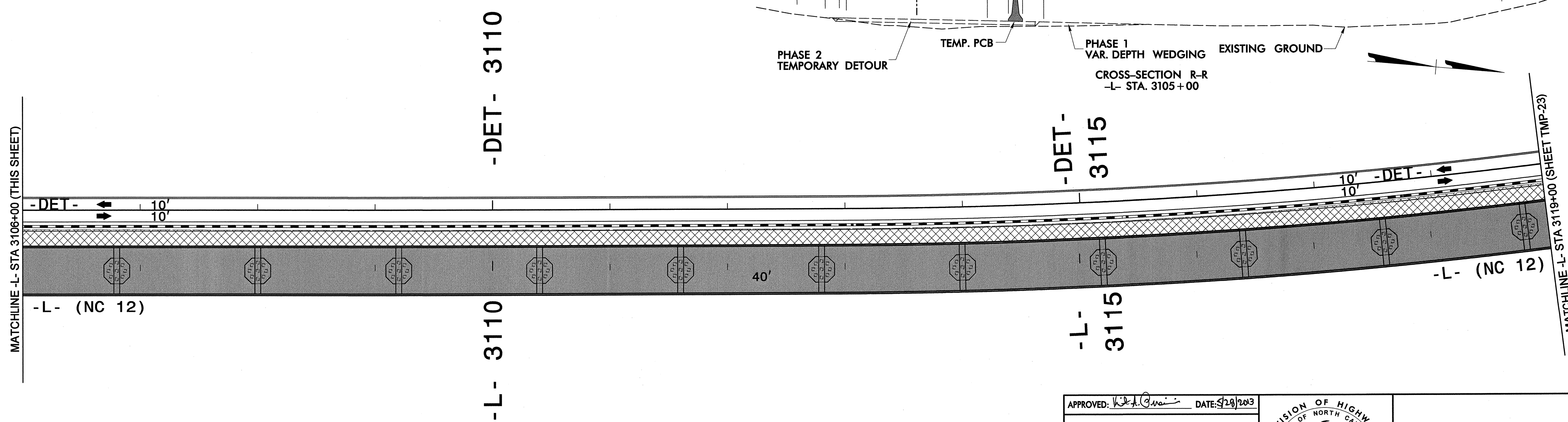
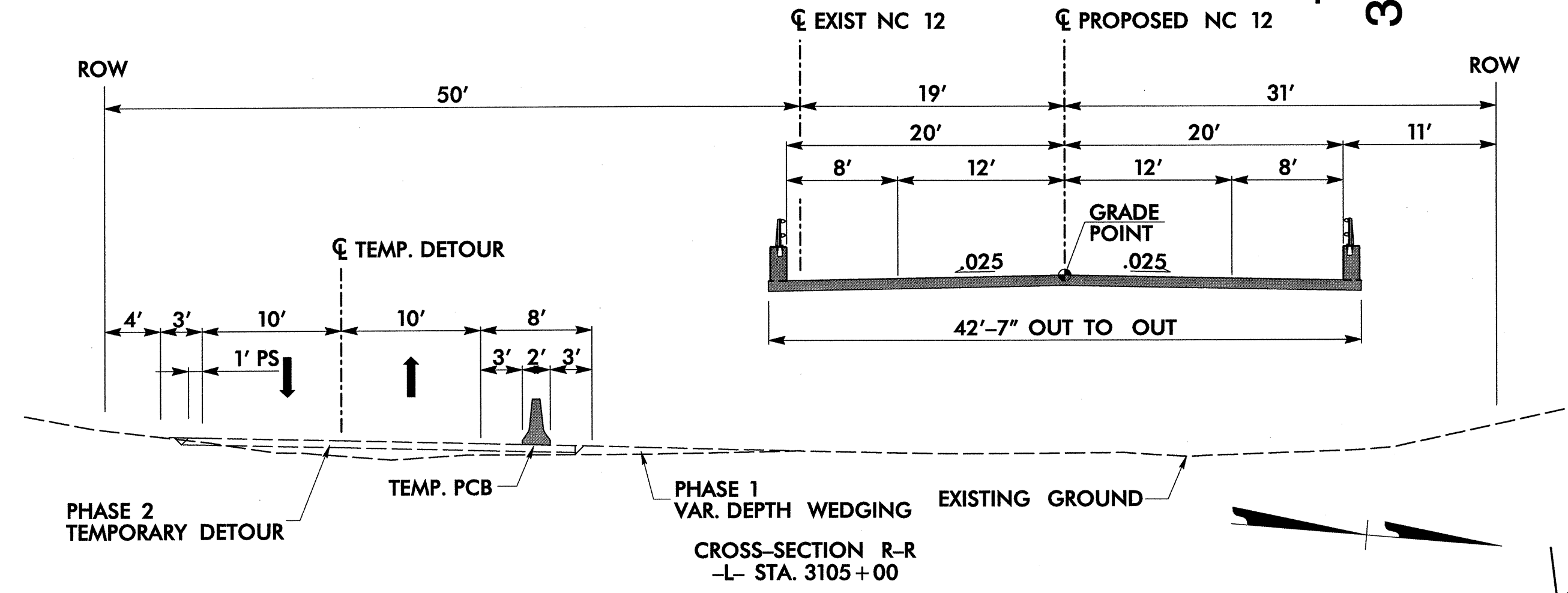
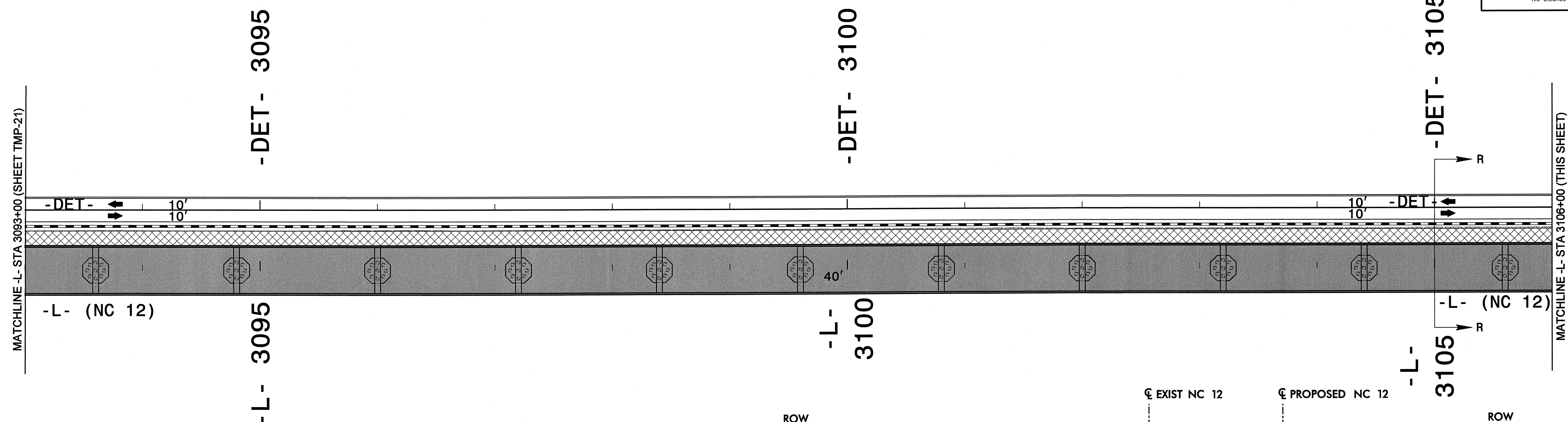

5/24/2013 r:\traffic\traffcontrol\ncp\nc12\PEA\_TC\_TMP\_22.dgn

APPROVED: *[Signature]* DATE: 5/28/2013

SEAL

  
 NORTH CAROLINA  
 PROFESSIONAL  
 ENGINEER  
 KIT A. PERSIANI

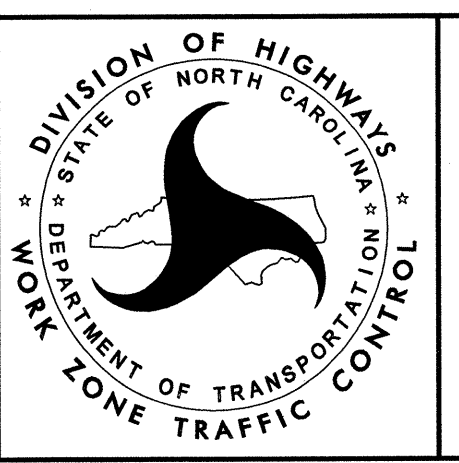

**TEMPORARY TRAFFIC CONTROL  
PHASE V DETAIL**



r:\traffic\trafficcontrol\ncp\NIC12PEA\_TC\_TMP\_23.dgn

5/24/2013

PROJ. REFERENCE NO.	SHEET NO.
B-2500A	TMP-23
 <b>STV / Ralph Whitehead Associates, Inc.</b> <small>1000 West Morehead St., Ste. 200 Charlotte, NC 28208 NC License Number F-0991</small>	

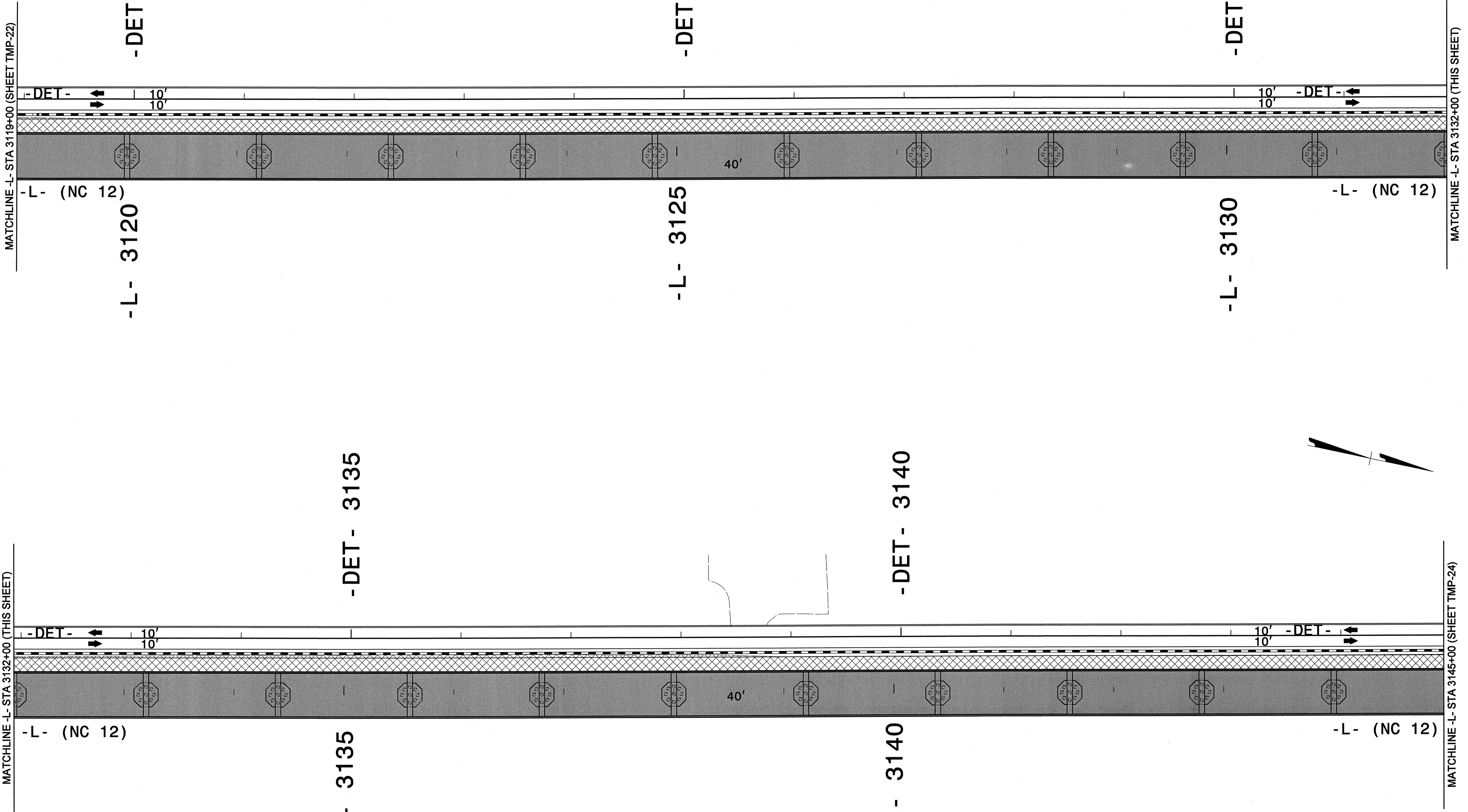

APPROVED: *Kit A. Persiani* DATE: 5/28/2013

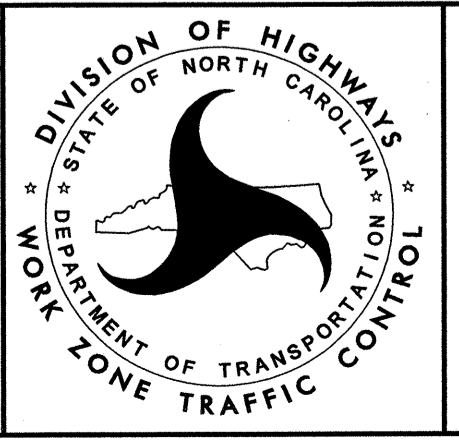
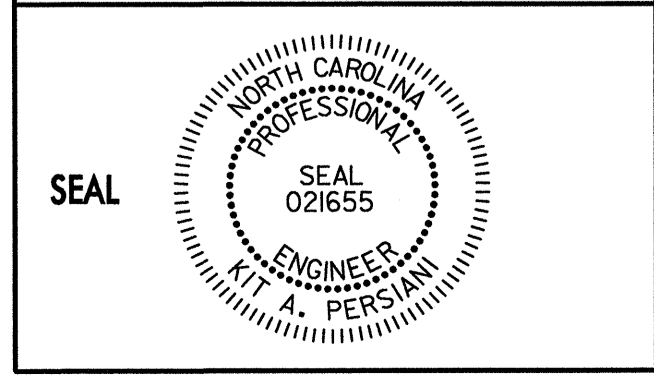

TEMPORARY TRAFFIC CONTROL  
PHASE V DETAIL



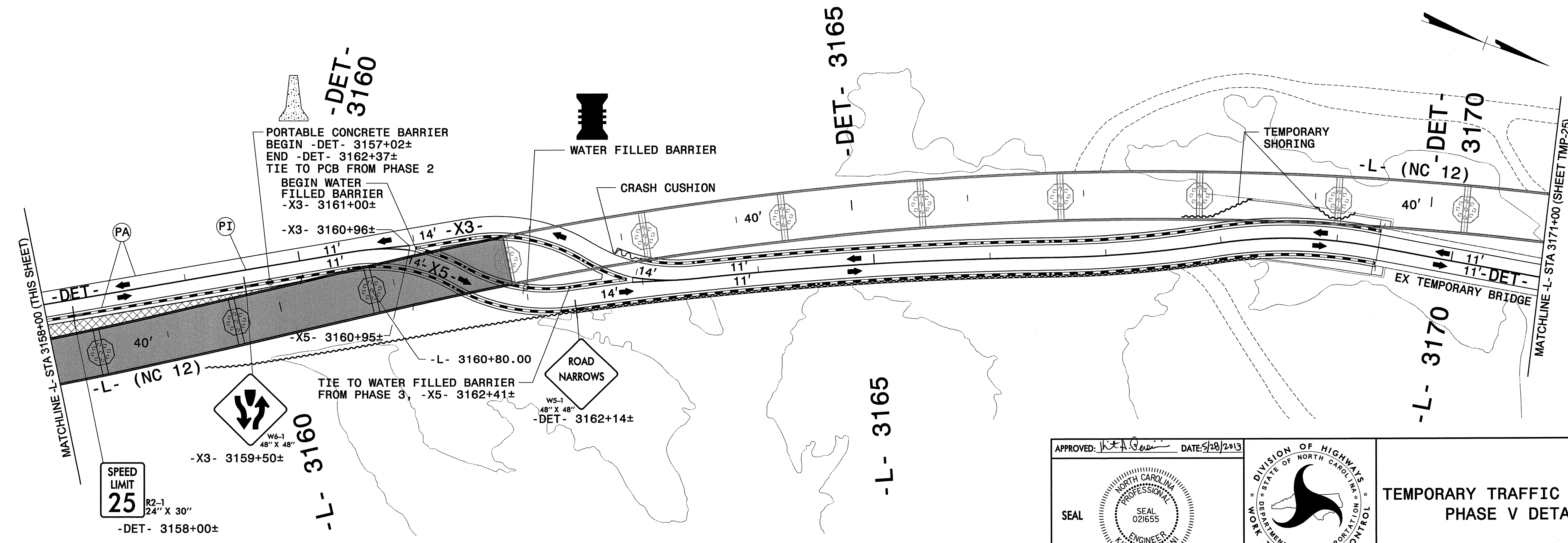
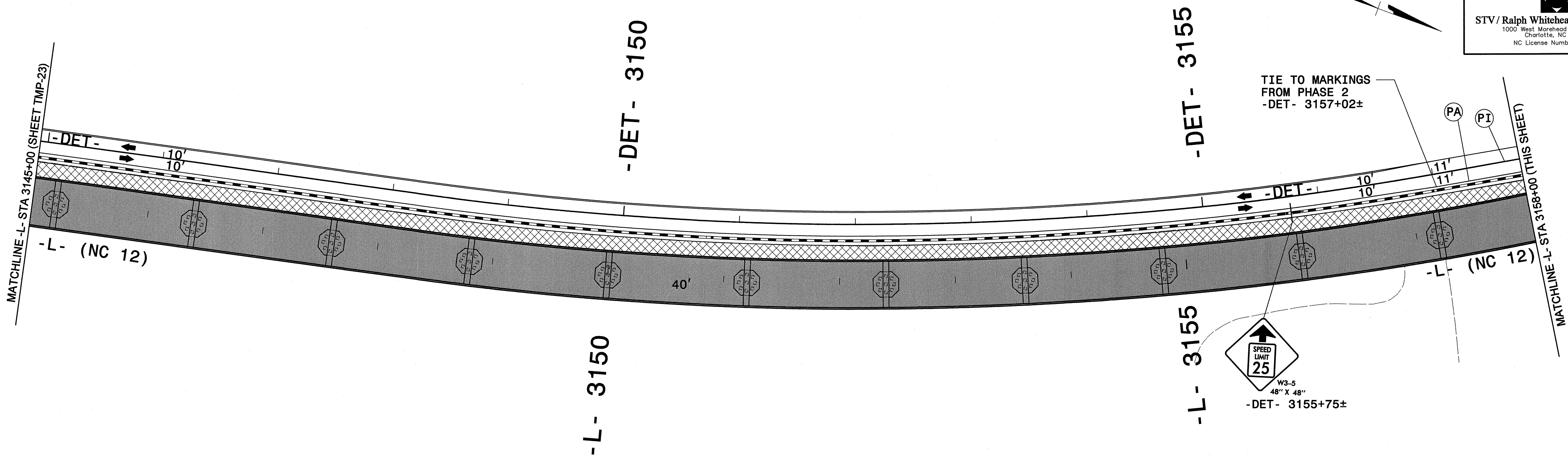

5/24/2013  
 r:\traffic\trafficcontrol\nc\2500A\_TC\_TMP\_24.dgn

APPROVED: *[Signature]* DATE: 5/28/2013

SEAL

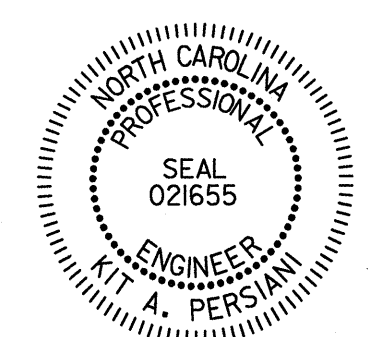
  
 NORTH CAROLINA  
 PROFESSIONAL  
 ENGINEER  
 M. A. PERSIANI  
 021655

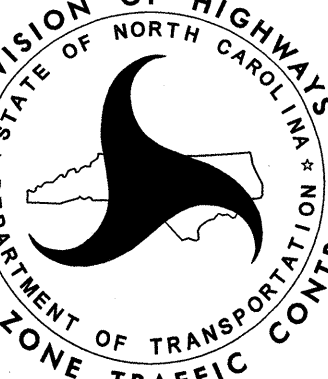

  
 DIVISION OF HIGHWAYS  
 STATE OF NORTH CAROLINA  
 DEPARTMENT OF TRANSPORTATION  
 WORK ZONE TRAFFIC CONTROL

**TEMPORARY TRAFFIC CONTROL  
PHASE V DETAIL**

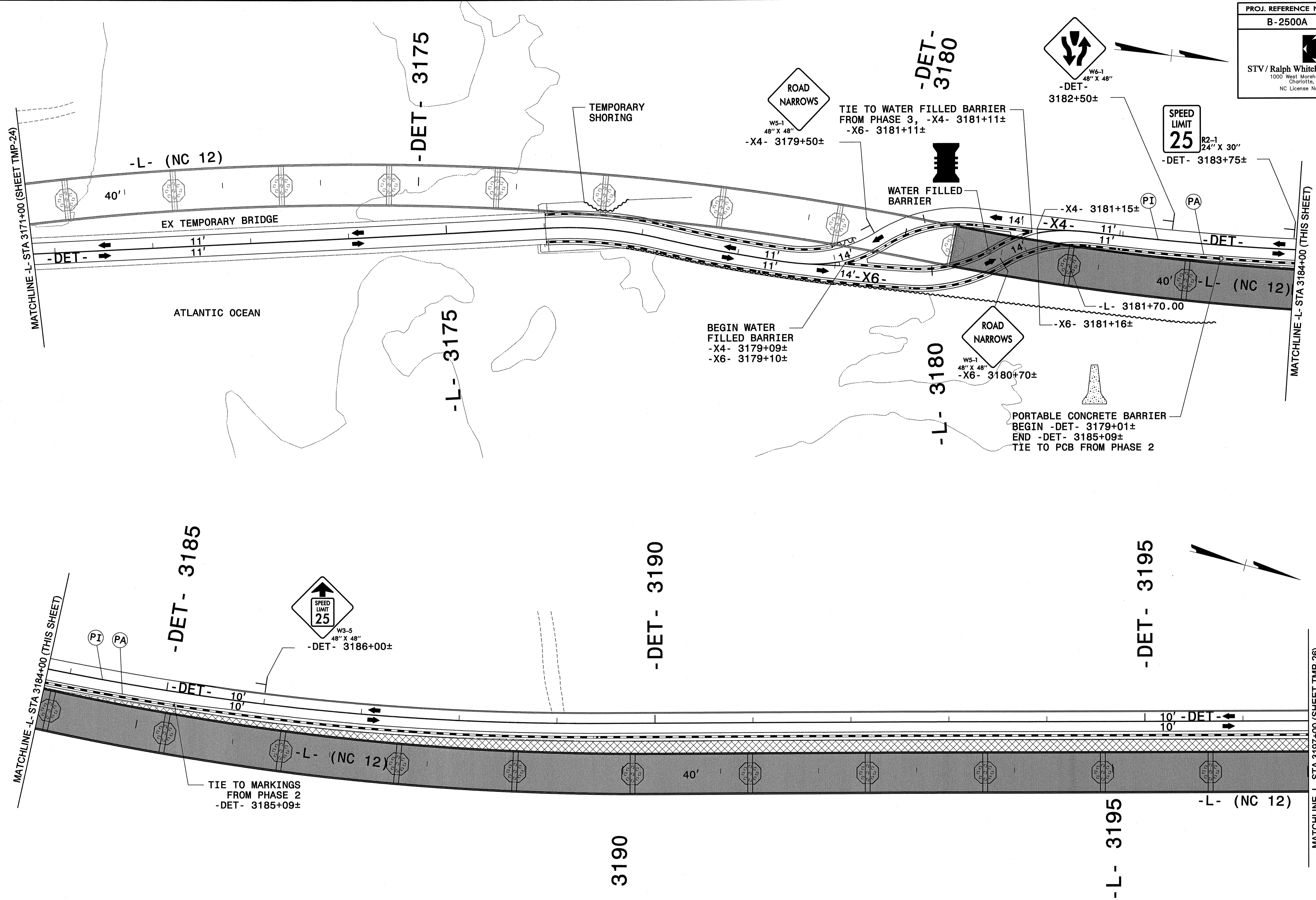

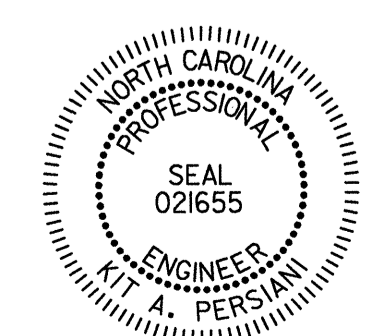

5/24/2013 r:\traffic\trafficcontrol\top\NIC12PEA\_TC\_TMP\_25.dgn

APPROVED: <i>[Signature]</i> DATE: 5/24/2013			<b>TEMPORARY TRAFFIC CONTROL PHASE V DETAIL</b>
--	---	---	---



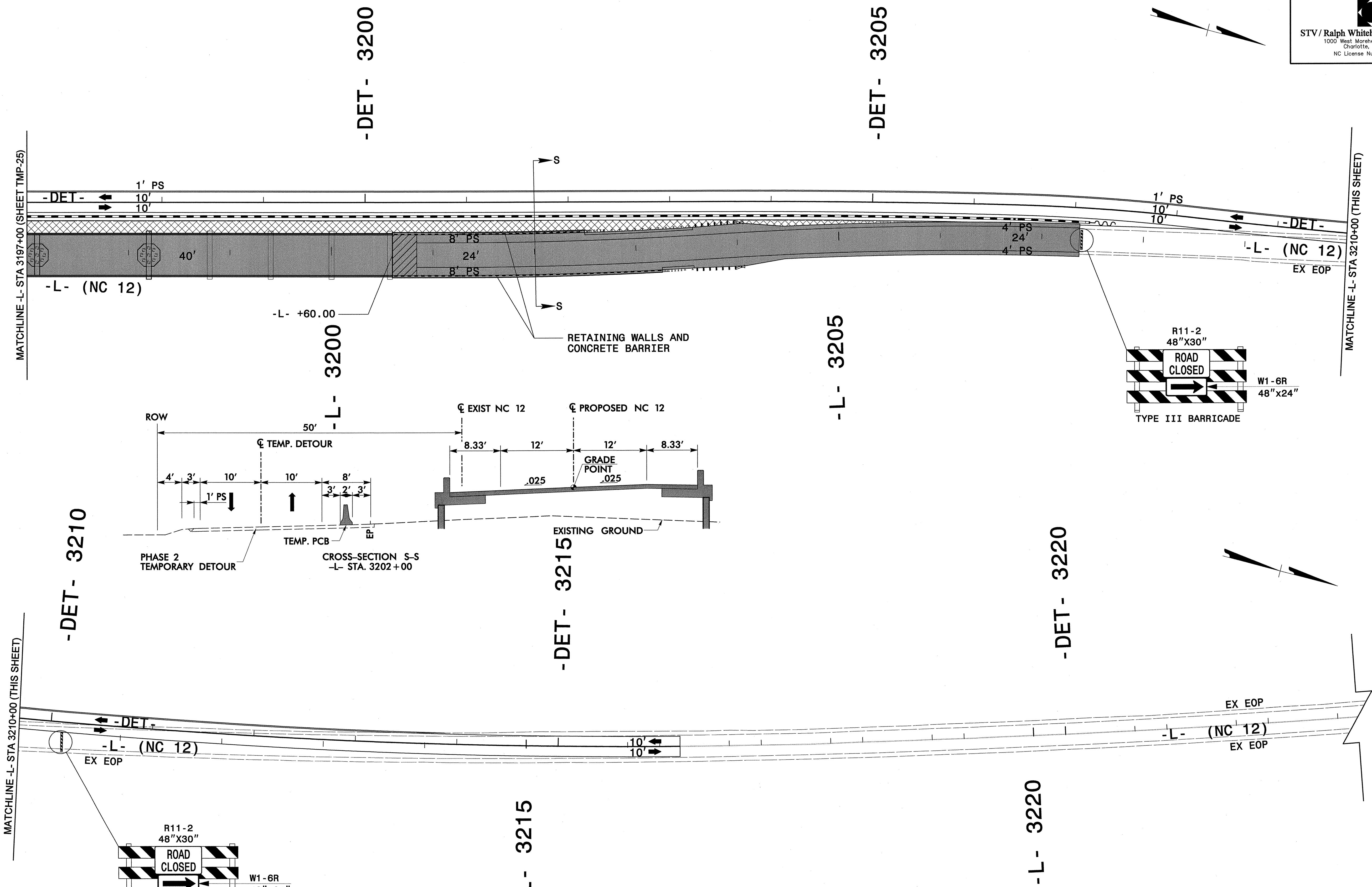

5/24/2013 r:\traffic\trafficcontrol\ncp\nc12\PEA\_TC\_TMP\_26.dgn

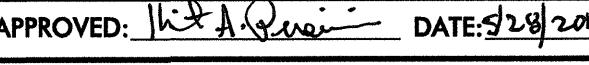
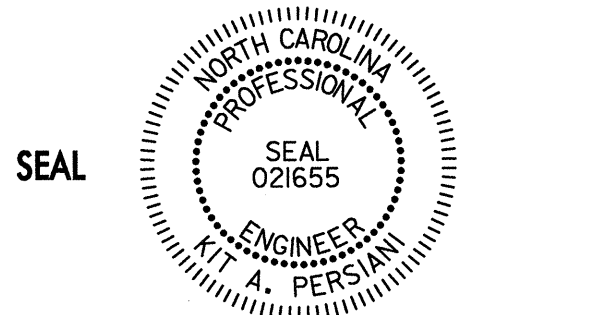
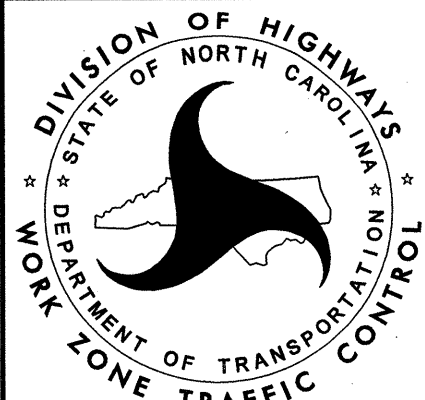
APPROVED:  DATE: 5/24/2013			<b>TEMPORARY TRAFFIC CONTROL PHASE V DETAIL</b>
---	---	---	---