

**STATE OF NORTH CAROLINA  
DEPARTMENT OF TRANSPORTATION**

**SIGNING & PAVEMENT MARKING PLAN  
DARE COUNTY**

**LOCATION: PHASE II, NC 12 LONG-TERM IMPROVEMENTS AT PEA ISLAND**

**PROJECT: B-2500A**

**CONTRACT: C203171**

**INDEX**

SHEET NO.	DESCRIPTION
PMP-1	SIGNING & PAVEMENT MARKING PLAN COVER SHEET
PMP-1A	FINAL PAVEMENT MARKING SCHEDULE
PMP-1B	SIGN DESIGNS
PMP-2 - PMP-6	SIGNING & PAVEMENT MARKING DETAILS

**ROADWAY STANDARD DRAWING**

THE FOLLOWING ROADWAY STANDARDS AS APPEAR IN "ROADWAY STANDARD DRAWINGS" - PROJECT SERVICES UNIT - N.C. DEPARTMENT OF TRANSPORTATION - RALEIGH, N.C., DATED JANUARY 2012 ARE APPLICABLE TO THIS PROJECT AND BY REFERENCE HEREBY ARE CONSIDERED A PART OF THESE PLANS:

STD. NO.	TITLE
903.30	BARRIER SIGN SUPPORT ASSEMBLY
904.10	ORIENTATION OF GROUND MOUNTED SIGN SUPPORTS
904.40	MILEPOST AND PLACEMENT
1205.01	PAVEMENT MARKINGS - LINE TYPES AND OFFSETS
1205.02	PAVEMENT MARKINGS - TWO-LANE AND MULTILANE ROADWAYS
1205.04	PAVEMENT MARKINGS - INTERSECTIONS
1205.05	PAVEMENT MARKINGS - TURN LANES
1205.08	PAVEMENT MARKINGS - SYMBOLS AND WORD MESSAGES
1205.09	PAVEMENT MARKINGS - PAINTED ISLANDS
1205.12	PAVEMENT MARKINGS - BRIDGES
1250.01	RAISED PAVEMENT MARKERS - INSTALLATION SPACING
1251.01	RAISED PAVEMENT MARKERS - PERMANENT AND TEMPORARY
1261.01	GUARDRAIL AND BARRIER DELINEATORS - INSTALLATION SPACING
1261.02	GUARDRAIL AND BARRIER DELINEATORS - TYPES AND MOUNTING
1262.01	GUARDRAIL END DELINEATION

**GENERAL NOTES**

THE FOLLOWING GENERAL NOTES APPLY AT ALL TIMES FOR THE DURATION OF THE CONSTRUCTION PROJECT, EXCEPT WHEN OTHERWISE NOTED IN THE PLAN, OR DIRECTED BY THE ENGINEER.

- A) INSTALL PAVEMENT MARKINGS AND PAVEMENT MARKERS ON THE FINAL SURFACE AS FOLLOWS:

ROAD NAME	MARKING	MARKER
NC 12	THERMOPLASTIC	RAISED
NC 12 (BRIDGE)	HIGHLY REFLECTIVE ELEMENTS POLYUREA	RAISED
- B) TIE PROPOSED PAVEMENT MARKING LINES TO EXISTING PAVEMENT MARKING LINES.
- C) REMOVE/REPLACE ANY CONFLICTING/DAMAGED PAVEMENT MARKINGS AND MARKERS.
- D) PASSING ZONES WILL BE DETERMINED IN THE FIELD AND MUST BE APPROVED BY THE ENGINEER.
- E) REMOVE ALL RESIDUE AND SURFACE LAITANCE BY ACCEPTABLE METHODS ON THE CONCRETE SURFACES PRIOR TO PLACING COLD APPLIED PLASTIC PAVEMENT MARKING MATERIAL.
- F) MARKERS SHALL BE INSTALLED ACCORDING TO THE NCDOT ROADWAY STANDARD DRAWING 1250.01.
- G) SIGN FURNISHED BY CONTRACTOR.
- H) THE BACKGROUND FOR MILEPOST SIGNS SHALL BE GRADE "C" REFLECTIVE SHEETING. THE LEGEND AND BORDER FOR MILEPOST SIGNS SHALL BE GRADE "C" REFLECTIVE SHEETING.

**SIGNS SUMMARY OF QUANTITIES**

ITEM NO.	ITEM DESCRIPTION	QUANTITY	UNIT
4025000000	CONTRACTOR FURNISHED, TYPE D SIGN	39	SF
4025000000	CONTRACTOR FURNISHED, TYPE E SIGN	77	SF
4025000000	CONTRACTOR FURNISHED, TYPE MILEMARKER SIGN	18	SF
4072000000	SUPPORTS, 3-LB STEEL U-CHANNEL	321	LF
4078000000	SUPPORTS, 2-LB STEEL U-CHANNEL	6	EA
4096000000	SIGN ERECTION, TYPE D	5	EA
4102000000	SIGN ERECTION, TYPE E	15	EA
4114000000	SIGN ERECTION, MILEMARKERS	6	EA

**PLAN REVIEWED BY: N.C.D.O.T. SIGNING AND DELINEATION UNIT**

<b>AYMAN ALQUDWAH, PE</b>	SIGNING & DELINEATION REGIONAL ENGINEER
<b>MITCH EATON</b>	SIGNING & DELINEATION PROJECT DESIGN ENGINEER

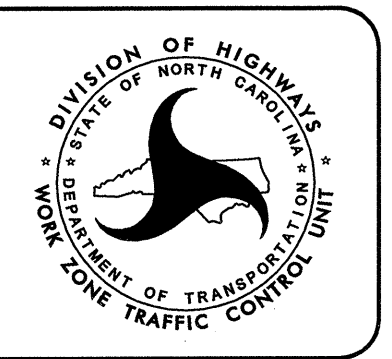

**PLAN PREPARED BY:  
STV / Ralph Whitehead Associates, Inc.**

<b>KIT A. PERSIANI, PE</b>	TRAFFIC ENGINEER
<b>SEAN C. STEPHENS, EI</b>	TRANSPORTATION DESIGNER

  
**STV / Ralph Whitehead Associates, Inc.**  
 1000 West Morehead St., Ste. 200  
 Charlotte, NC 28208  
 NC License Number F-0991

**CONTRACT: C203171**

**PROJECT: B-2500A**

**STATE OF NORTH CAROLINA  
 DEPARTMENT OF TRANSPORTATION**

**SIGNING & PAVEMENT MARKING PLAN  
 DARE COUNTY**

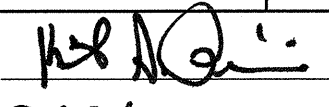
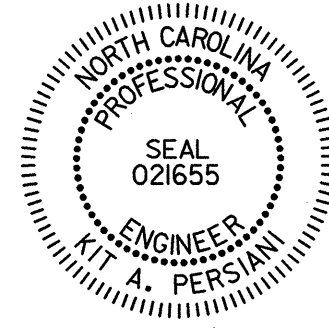
TIP NO. B-2500A	SHEET NO. PMP-1A
APPROVED: 	
DATE: 9/19/13	
SEAL	
	

**FINAL PAVEMENT MARKING SCHEDULE**

<u>SYMBOL</u>	<u>DESCRIPTION</u>	<u>BREAKDOWN</u>	<u>PAY ITEM</u>
PAVEMENT MARKING LINES			
T2	WHITE STOPBAR		THERMOPLASTIC (24", 120 MILS)
T13	3' - 9' WHITE MINISKIP		THERMOPLASTIC (8", 120 MILS)
TA	WHITE EDGE LINE		THERMOPLASTIC (4", 90 MILS)
TB	YELLOW EDGE LINE		THERMOPLASTIC (4", 90 MILS)
TE	WHITE SOLID LANE LINE		THERMOPLASTIC (4", 120 MILS)
TI	YELLOW DOUBLE CENTER LINE		THERMOPLASTIC (4", 120 MILS)
TP	YELLOW DIAGONAL LINE		THERMOPLASTIC (8", 90 MILS)
VA	WHITE EDGE LINE		POLYUREA (4")
VI	YELLOW DOUBLE CENTER LINE		POLYUREA (4")
PAVEMENT SYMBOLS			
UA	LEFT TURN ARROW		THERMOPLASTIC (90 MILS)
UC	STRAIGHT ARROW		THERMOPLASTIC (90 MILS)
UE	COMBO. STRAIGHT / RIGHT ARROW		THERMOPLASTIC (90 MILS)
PAVEMENT MARKERS			
MA	YELLOW & YELLOW		PERMANENT RAISED



STV/Ralph Whitehead Associates, Inc.  
1000 West Morehead St., Ste. 200  
Charlotte, NC 28208  
NC License Number F-0991

TIP NO. SHEET NO.

B-2500A PMP-1B

APPROVED: *[Signature]*

DATE: 9/19/2013

SEAL

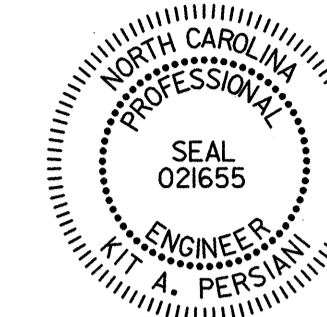

**SIGN NUMBER:** 303  
**TYPE:** D  
**QUANTITY:** 1  
**SIGN WIDTH:** 6'-0"  
**HEIGHT:** 1'-6"  
**TOTAL AREA:** 9.0 Sq.Ft.  
**BORDER TYPE:** FLUSH  
**RECESS:** 0"  
**WIDTH:** 0.5"  
**RADII:** 1.5"  
**NO. Z BARS:**  
**LENGTH:**

**BACKG COLOR:** Green  
**COPY COLOR:** White

SYMBOL	X	Y	WID	HT
AR_Type D	57.9	6	6	9

**DESIGN BY:** none  
**CHECKED BY:**  
**PROJECT ID:** B-2500A  
**DIV:** 1  
**DATE:** Sep 18, 2013

**USE NOTES:** 1,2  
1. Legend and border(except those that are colored black) shall be direct applied Grade C sheeting.  
2. Background shall be Grade C reflective sheeting.

Letter spacings are to start of next letter

Series/Size	Text Length
D 2000	46.9

FILENAME: B-2500A\_Sign-RS-118 NORTH CAROLINA D.O.T. SIGN DETAIL

**SIGN NUMBER:** 305  
**TYPE:** D  
**QUANTITY:** 1  
**SIGN WIDTH:** 6'-0"  
**HEIGHT:** 1'-6"  
**TOTAL AREA:** 9.0 Sq.Ft.  
**BORDER TYPE:** FLUSH  
**RECESS:** 0"  
**WIDTH:** 0.5"  
**RADII:** 1.5"  
**NO. Z BARS:**  
**LENGTH:**

**BACKG COLOR:** Green  
**COPY COLOR:** White

SYMBOL	X	Y	WID	HT
AR_Type D	5.1	6	6	9

**DESIGN BY:** none  
**CHECKED BY:**  
**PROJECT ID:** B-2500A  
**DIV:** 1  
**DATE:** Sep 18, 2013

**USE NOTES:** 1,2  
1. Legend and border(except those that are colored black) shall be direct applied Grade C sheeting.  
2. Background shall be Grade C reflective sheeting.

Letter spacings are to start of next letter

Series/Size	Text Length
D 2000	46.9

FILENAME: B-2500A\_Sign-RS-118 NORTH CAROLINA D.O.T. SIGN DETAIL

**SIGN NUMBER:** 304  
**TYPE:** D  
**QUANTITY:** 1  
**SIGN WIDTH:** 6'-0"  
**HEIGHT:** 1'-6"  
**TOTAL AREA:** 9.0 Sq.Ft.  
**BORDER TYPE:** FLUSH  
**RECESS:** 0"  
**WIDTH:** 0.5"  
**RADII:** 1.5"  
**NO. Z BARS:**  
**LENGTH:**

**BACKG COLOR:** Green  
**COPY COLOR:** White

SYMBOL	X	Y	WID	HT
AR_Type D	6.6	4.5	6	9

**DESIGN BY:** none  
**CHECKED BY:**  
**PROJECT ID:** B-2500A  
**DIV:** 1  
**DATE:** Sep 18, 2013

**USE NOTES:** 1,2  
1. Legend and border(except those that are colored black) shall be direct applied Grade C sheeting.  
2. Background shall be Grade C reflective sheeting.

Letter spacings are to start of next letter

Series/Size	Text Length
D 2000	46.9

FILENAME: B-2500A\_Sign-RS-118 NORTH CAROLINA D.O.T. SIGN DETAIL

**SIGN NUMBER:** 301,302  
**TYPE:** D  
**QUANTITY:** 2  
**SIGN WIDTH:** 3'-0"  
**HEIGHT:** 2'-0"  
**TOTAL AREA:** 6.0 Sq.Ft.  
**BORDER TYPE:** FLUSH  
**RECESS:** 0"  
**WIDTH:** 0.5"  
**RADII:** 3"  
**NO. Z BARS:**  
**LENGTH:**

**BACKG COLOR:** Green  
**COPY COLOR:** White

SYMBOL	X	Y	WID	HT
AR_Type D				

**DESIGN BY:** none  
**CHECKED BY:**  
**PROJECT ID:** B-2500A  
**DIV:** 1  
**DATE:** Sep 13, 2013

**USE NOTES:** 1,2  
1. Legend and border(except those that are colored black) shall be direct applied Grade C sheeting.  
2. Background shall be Grade C reflective sheeting.

Letter spacings are to start of next letter

Series/Size	Text Length
B 2000	29.7
B 2000	11

FILENAME: B-2500A\_Sign-RS-118 NORTH CAROLINA D.O.T. SIGN DETAIL

**SIGN DESIGNS**

9/19/2013  
R:\Roadway\Proj\MP\NC12PEA\_Lrdy\_PMP01B.dgn  
ogroves

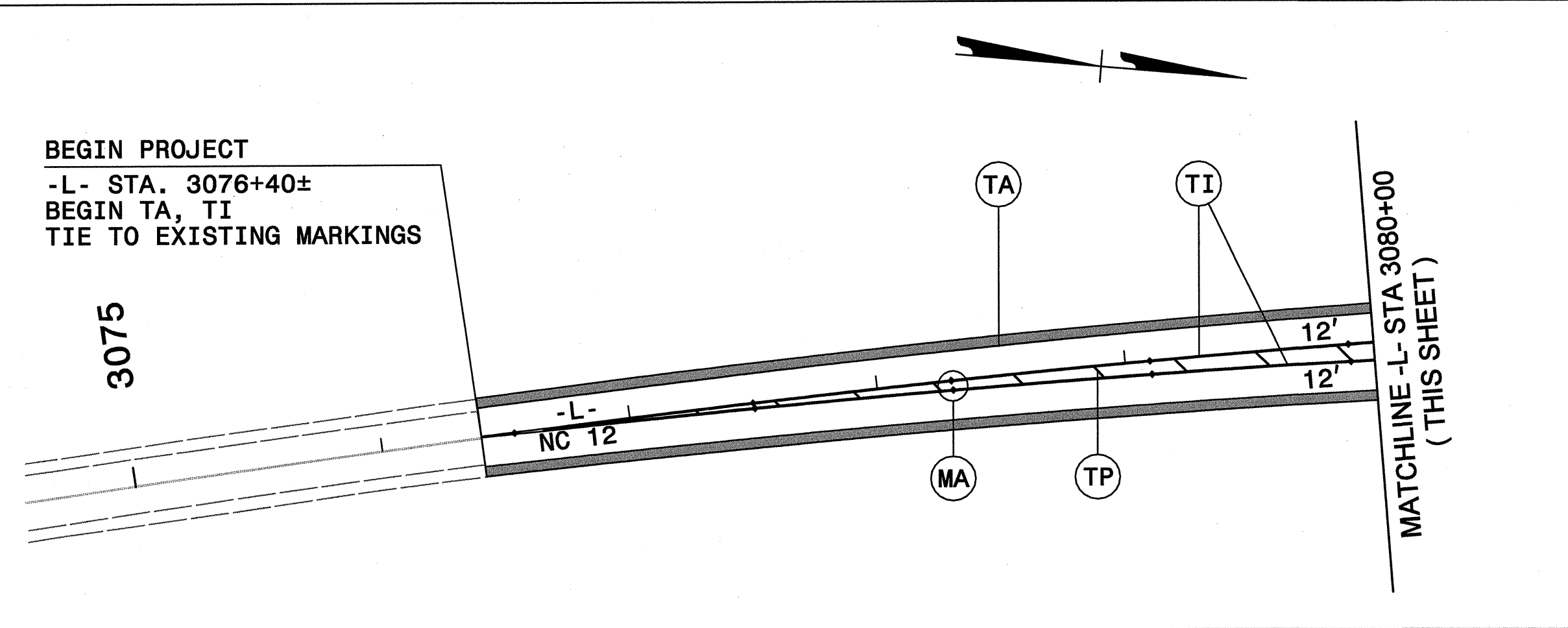
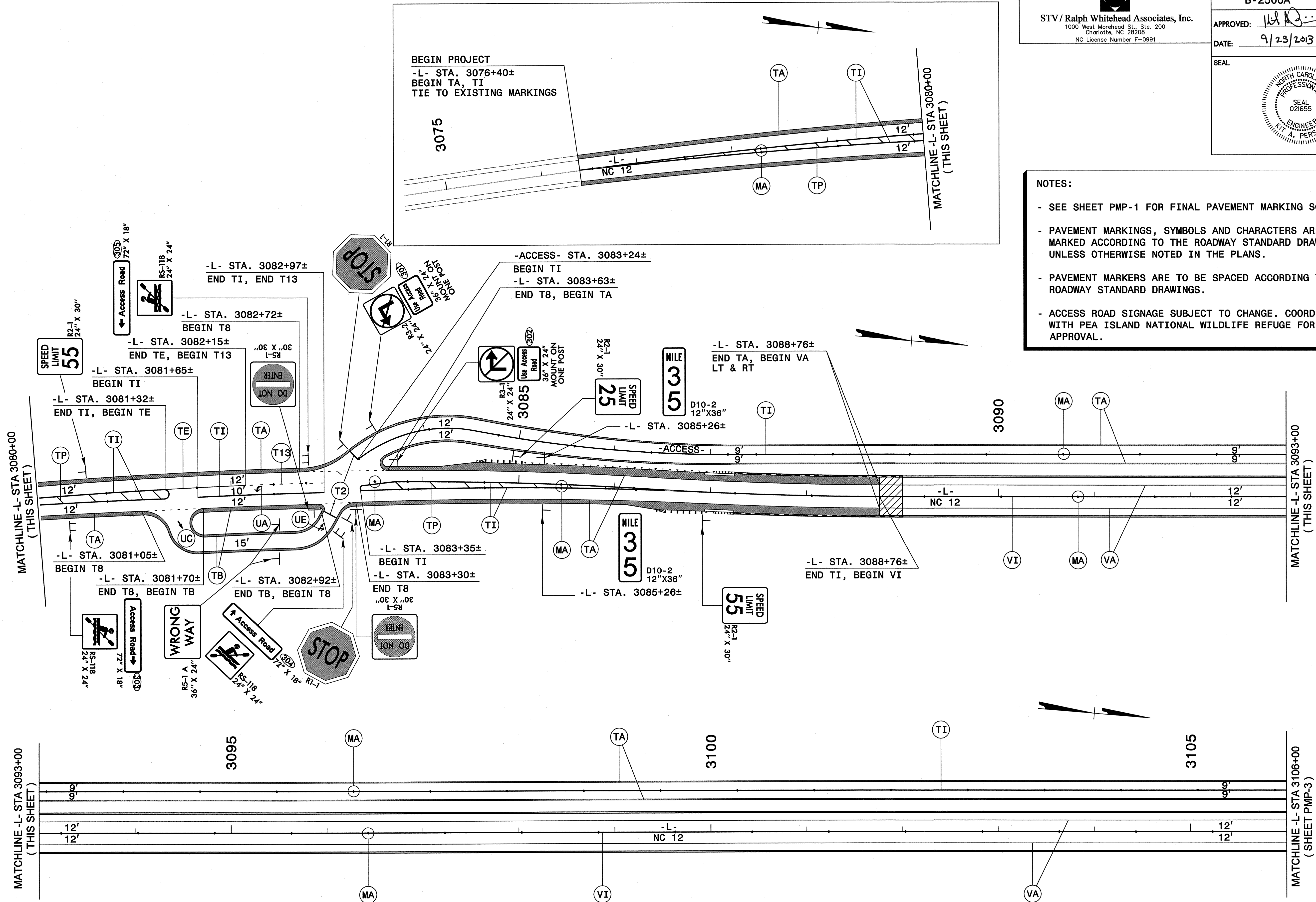

**NOTES:**

- SEE SHEET PMP-1 FOR FINAL PAVEMENT MARKING SCHEDULE.
- PAVEMENT MARKINGS, SYMBOLS AND CHARACTERS ARE TO BE MARKED ACCORDING TO THE ROADWAY STANDARD DRAWINGS UNLESS OTHERWISE NOTED IN THE PLANS.
- PAVEMENT MARKERS ARE TO BE SPACED ACCORDING TO THE ROADWAY STANDARD DRAWINGS.
- ACCESS ROAD SIGNAGE SUBJECT TO CHANGE. COORDINATE WITH PEA ISLAND NATIONAL WILDLIFE REFUGE FOR FINAL APPROVAL.

**SIGNING AND PAVEMENT MARKING DETAIL**



STV / Ralph Whitehead Associates, Inc.  
 1000 West Morehead St., Ste. 200  
 Charlotte, NC 28208  
 NC License Number F-0991

TIP NO.	SHEET NO.
B-2500A	PMP-3
APPROVED: <i>[Signature]</i>	
DATE: 9/16/2013	
SEAL	

**NOTES:**

- SEE SHEET PMP-1 FOR FINAL PAVEMENT MARKING SCHEDULE.
- PAVEMENT MARKINGS, SYMBOLS AND CHARACTERS ARE TO BE MARKED ACCORDING TO THE ROADWAY STANDARD DRAWINGS UNLESS OTHERWISE NOTED IN THE PLANS.
- PAVEMENT MARKERS ARE TO BE SPACED ACCORDING TO THE ROADWAY STANDARD DRAWINGS.

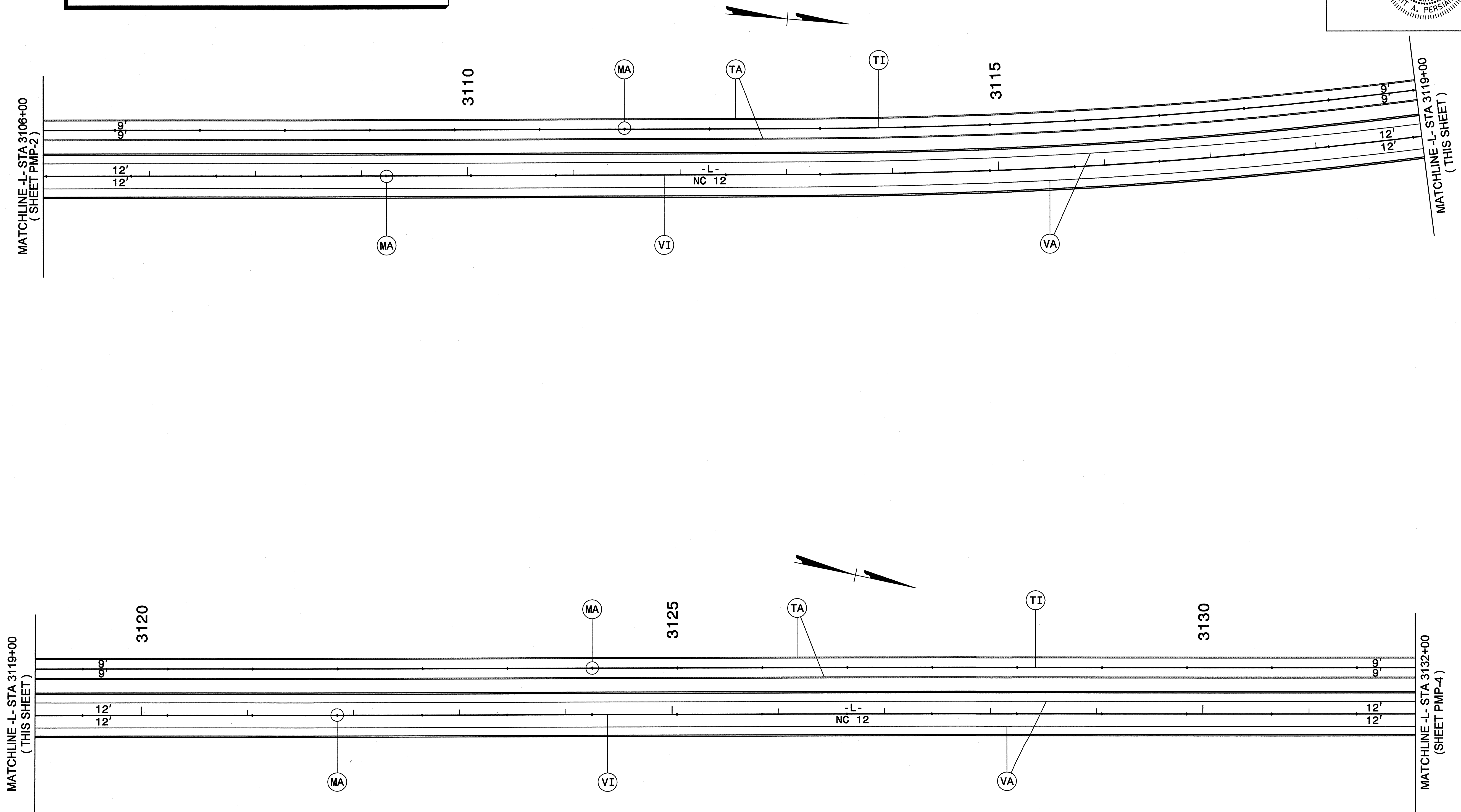

**SIGNING AND PAVEMENT MARKING DETAIL**

TIP NO.	SHEET NO.
B-2500A	PMP-4
APPROVED: <i>K.A. Persiani</i>	
DATE: 7/16/2013	
SEAL	

STV / Ralph Whitehead Associates, Inc.  
 1000 West Morehead St., Ste. 200  
 Charlotte, NC 28208  
 NC License Number F-0991

NOTES:

- SEE SHEET PMP-1 FOR FINAL PAVEMENT MARKING SCHEDULE.
- PAVEMENT MARKINGS, SYMBOLS AND CHARACTERS ARE TO BE MARKED ACCORDING TO THE ROADWAY STANDARD DRAWINGS UNLESS OTHERWISE NOTED IN THE PLANS.
- PAVEMENT MARKERS ARE TO BE SPACED ACCORDING TO THE ROADWAY STANDARD DRAWINGS.

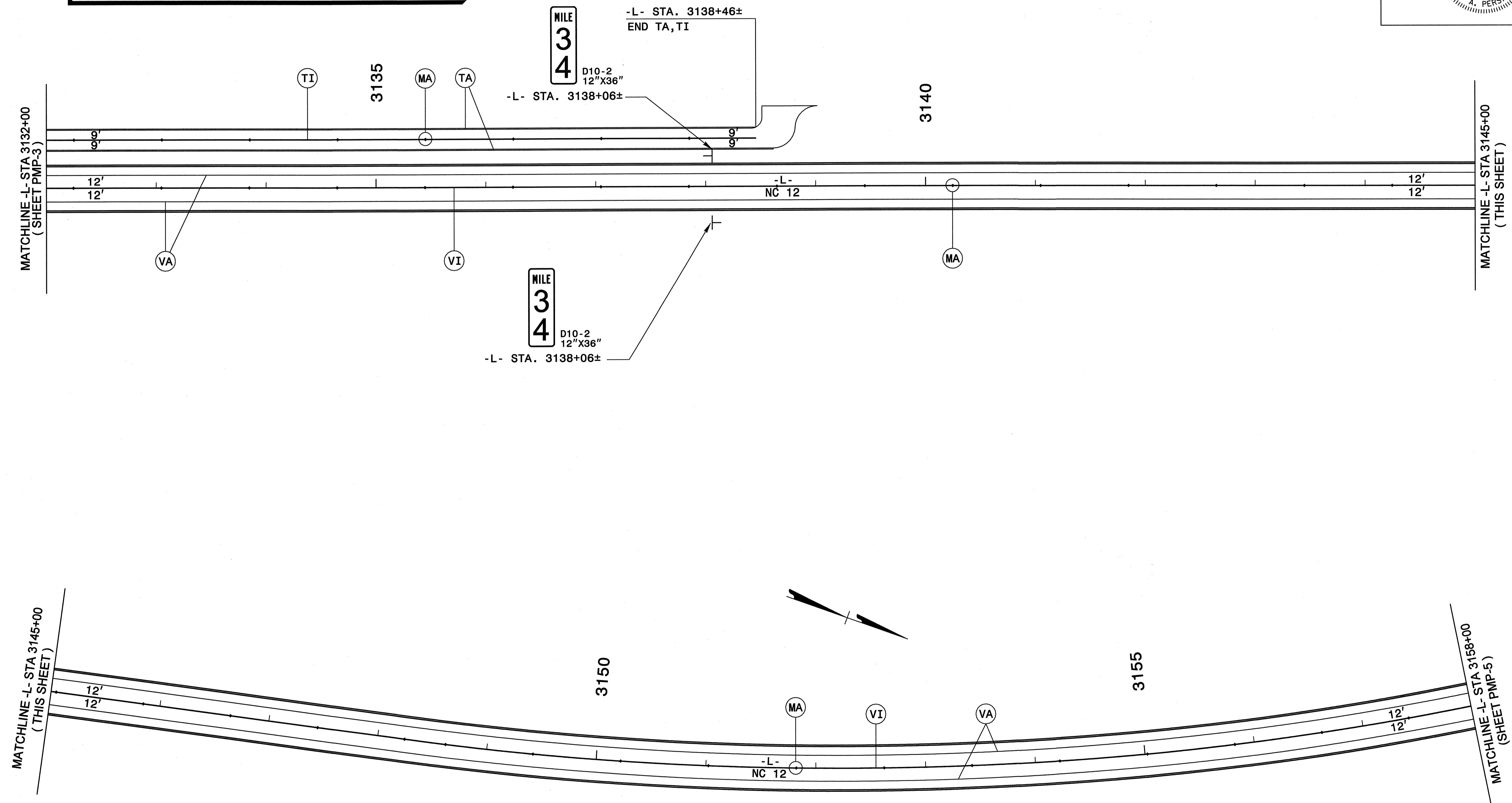

**SIGNING AND PAVEMENT MARKING DETAIL**

9/16/2013  
 R:\Roadway\Proj\PM\NCC2PEA\_Lrdy\_PMP04.dgn  
 cgroves

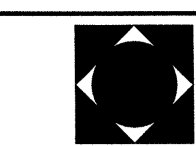

STV / Ralph Whitehead Associates, Inc.  
 1000 West Morehead St., Ste. 200  
 Charlotte, NC 28208  
 NC License Number F-0991

TIP NO.	SHEET NO.
B-2500A	PMP-5
APPROVED: <i>[Signature]</i>	
DATE: 9/14/2013	
SEAL	

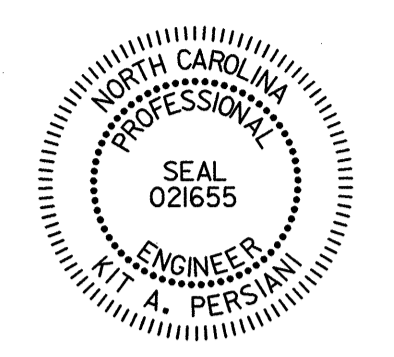

**NOTES:**

- SEE SHEET PMP-1 FOR FINAL PAVEMENT MARKING SCHEDULE.
- PAVEMENT MARKINGS, SYMBOLS AND CHARACTERS ARE TO BE MARKED ACCORDING TO THE ROADWAY STANDARD DRAWINGS UNLESS OTHERWISE NOTED IN THE PLANS.
- PAVEMENT MARKERS ARE TO BE SPACED ACCORDING TO THE ROADWAY STANDARD DRAWINGS.

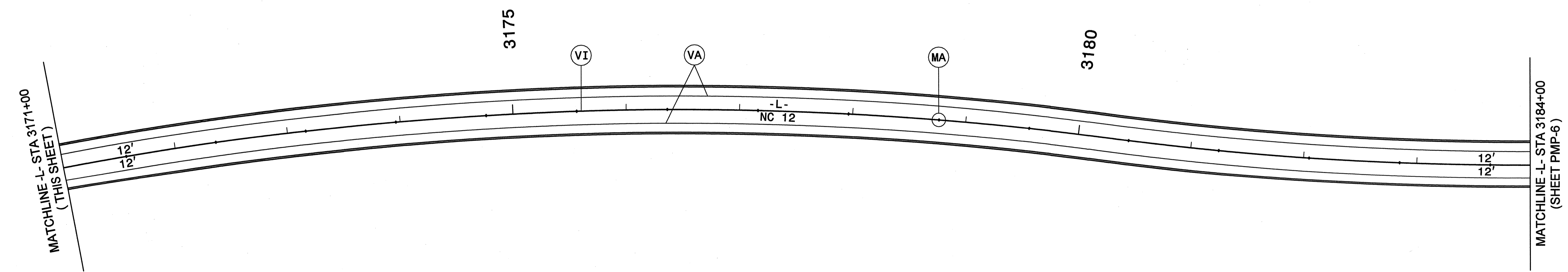
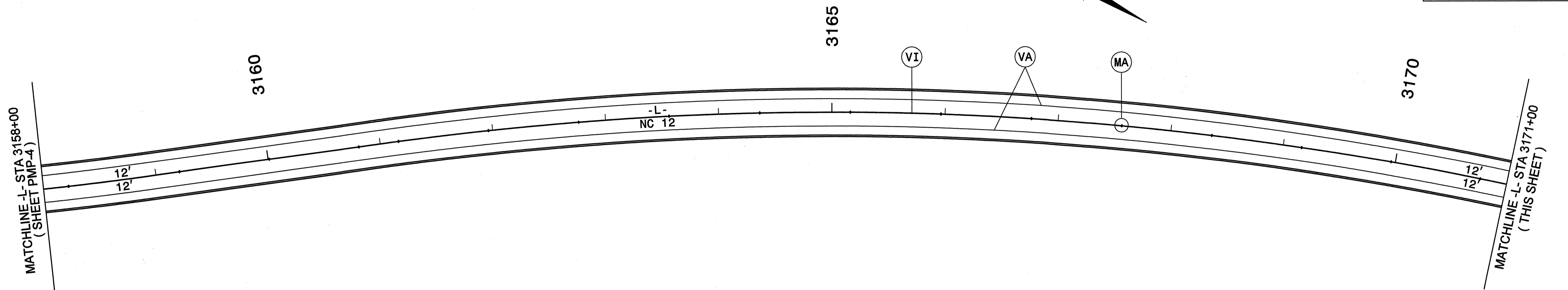

**SIGNING AND PAVEMENT MARKING DETAIL**

9/16/2013  
 R:\Roadway\Proj\PM\NCI2PEA\_Lrdy\_PMP05.dgn  
 ogroves

STV/Ralph Whitehead Associates, Inc.  
1000 West Morehead St., Ste. 200  
Charlotte, NC 28208  
NC License Number F-0991

APPROVED: *[Signature]*

DATE: 9/16/2013

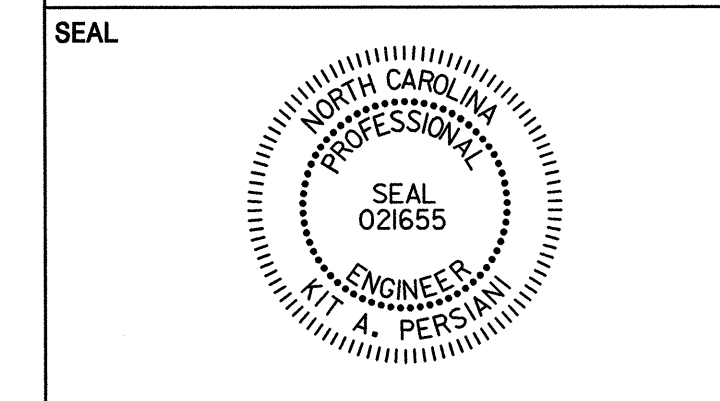

NOTES:  
- SEE SHEET PMP-1 FOR FINAL PAVEMENT MARKING SCHEDULE.  
- PAVEMENT MARKINGS, SYMBOLS AND CHARACTERS ARE TO BE MARKED ACCORDING TO THE ROADWAY STANDARD DRAWINGS UNLESS OTHERWISE NOTED IN THE PLANS.  
- PAVEMENT MARKERS ARE TO BE SPACED ACCORDING TO THE ROADWAY STANDARD DRAWINGS.

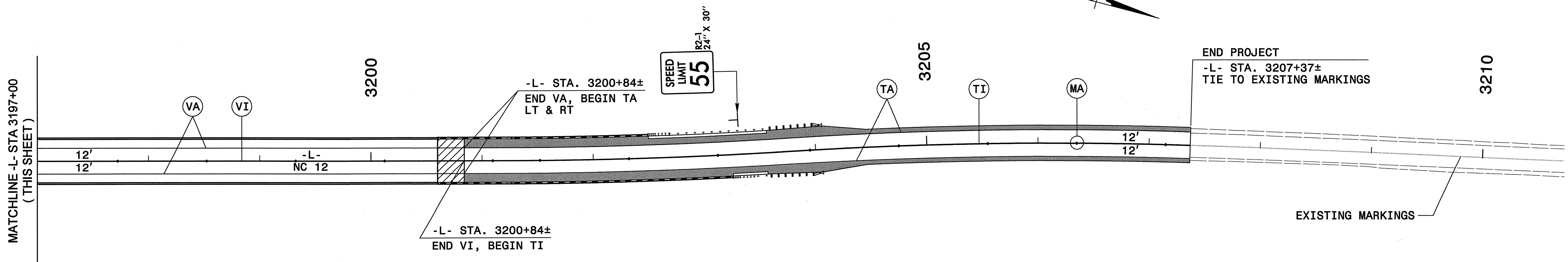
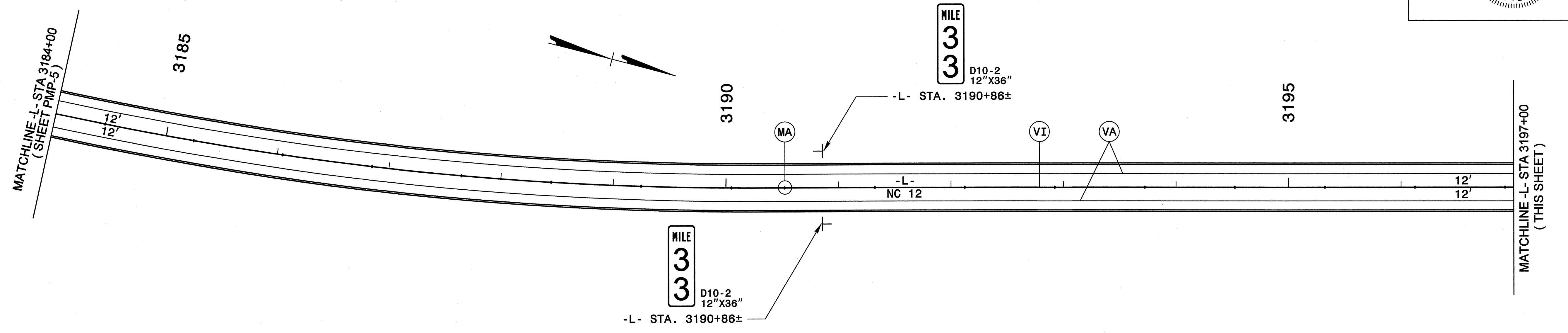

**SIGNING AND PAVEMENT MARKING DETAIL**

9/16/2013  
R:\Roadway\Proj\PM\NC12PEA\_rdy\_PMP06.dgn  
cgraves