

TIP NO. I-4733	SHEET NO. SIGN-1
APPROVED: <i>Betsy L. Watson</i>	
DATE: 4/26/13	
SEAL	

**STATE OF NORTH CAROLINA
DEPARTMENT OF TRANSPORTATION**

**SIGNING PLAN
MECKLENBURG COUNTY**

**LOCATION: CORNELIUS, MODIFY INTERCHANGE AT I-77
AND SR 5544 (W CATAWBA AVE)**

T.I.P.: I-4733

CONTRACT: C203203

ROADWAY STANDARD DRAWINGS

THE FOLLOWING ROADWAY STANDARDS AS APPEAR IN "ROADWAY STANDARD DRAWINGS" - PROJECT SERVICES UNIT - N.C. DEPARTMENT OF TRANSPORTATION - RALEIGH, N.C., DATED JANUARY 2012 ARE APPLICABLE TO THIS PROJECT AND BY REFERENCE HEREBY ARE CONSIDERED A PART OF THESE PLANS:

STD. NO.	TITLE
901.10	TYPE 'A' SIGNS
901.20	TYPE 'B' SIGNS
901.50	ARROWS AND SHIELDS
901.70	SIGN STRINGERS AND SUPPORT SPACING
901.80	SIGN MOUNTING DETAILS - FOR TYPE A AND TYPE B SIGNS
903.10	GROUND MOUNTED SIGN SUPPORTS
904.10	ORIENTATION OF GROUND MOUNTED SIGNS
904.50	MOUNTING OF TYPE 'D', 'E' AND 'F' SIGNS ON 'U' CHANNEL POSTS

GENERAL NOTES

- . SIGNS FURNISHED BY STATE.
- . ALL TYPE 'D' SIGNS SHALL BE MOUNTED ON TWO U-CHANNEL POSTS UNLESS OTHERWISE INDICATED ON THE PLANS.
- . IF REMOVAL OR RELOCATION OF SIGNS ON PRIVATE STREET (NON-STATE MAINTAINED) IS REQUIRED DUE TO CONSTRUCTION, THE CONTRACTOR SHALL INFORM THE ENGINEER. THE WORK WILL BE COMPLETED BY OTHERS.
- . SIGNING PLANS DO NOT INCLUDE TEMPORARY CONSTRUCTION SIGNING. SEE TRAFFIC CONTROL PLANS.
- . WHEN NOT STATIONED OR DIMENSIONED ON PLANS, ALL 'E' AND 'F' SIGNS SHALL BE FIELD LOCATED BY THE ENGINEER
- . ALL EXISTING SIGNS ON "U" CHANNEL POST WITHIN THE PROJECT LIMITS SHALL BE REMOVED AND DISPOSED OF UNLESS OTHERWISE NOTED ON PLANS.
- . WHEN EXISTING SIGNS ARE REMOVED AND INSTALLED ON NEW SUPPORTS, THE RE-ERECTION SHALL IMMEDIATELY FOLLOW THE REMOVAL.
- . THE BACKGROUND FOR TYPE E & F SIGNS SHALL BE TYPE C REFLECTIVE SHEETING.
- . SEE ROADWAY PLANS FOR GUARD/GUIDE RAIL DETAILS.

SUMMARY OF QUANTITIES

ITEM NO.		ITEM DESCRIPTION	QUANTITY	UNIT
DESC. NO.	SECT. NO.			
4048000000	902	REINFORCED CONCRETE SIGN FOUNDATIONS.....	7	C.Y.
4054000000	902	PLAIN CONCRETE SIGN FOUNDATIONS.....	2	C.Y.
4060000000	903	SUPPORTS, BREAKAWAY STEEL BEAM.....	7336	LB.
4066000000	903	SUPPORTS, SIMPLE STEEL BEAM.....	346	LB.
4072000000	903	SUPPORTS, 3-LB STEEL U-CHANNEL.....	1205	L.F.
4096000000	904	SIGN ERECTION, TYPE D.....	3	EA.
4102000000	904	SIGN ERECTION, TYPE E.....	67	EA.
4108000000	904	SIGN ERECTION, TYPE F.....	11	EA.
4110000000	904	SIGN ERECTION, TYPE A (GROUND MOUNTED).....	7	EA.
4116100000	904	SIGN ERECTION, RELOCATE, TYPE A (GROUND MOUNTED).....	6	EA.
4116100000	904	SIGN ERECTION, RELOCATE, TYPE B (GROUND MOUNTED).....	1	EA.
4116100000	904	SIGN ERECTION, RELOCATE, TYPE D.....	3	EA.
4116100000	904	SIGN ERECTION, RELOCATE, TYPE F.....	2	EA.
4138000000	907	DISPOSAL OF SUPPORT, STEEL BEAM.....	7	EA.
4155000000	907	DISPOSAL OF SIGN SYSTEM, U-CHANNEL.....	40	EA.
4192000000	907	DISPOSAL OF SUPPORT, U-CHANNEL.....	2	EA.
4238000000	907	DISPOSAL OF SIGN, D, E, OR F.....	1	EA.
4360000000	SP	GENERIC SIGNING ITEM (DISPOSAL OF SIGN SYSTEM ON SPAN WIRE).....	1	EA.

INDEX

SHEET NO.	DESCRIPTION
SIGN-1	TITLESHEET
SIGN-1A	REVISED SIGNING ROADWAY STANDARD DRAWING
SIGN-2	SUPPORT INFORMATION
SIGN-3-3A	E AND F SHEETS
SIGN-4-4B	SIGN DESIGNS
SIGN-5-8	SIGN DETAIL SHEETS

PLAN REVIEWED BY: N.C.D.O.T. SIGNING AND DELINEATION UNIT

KELVIN JORDAN SIGNING & DELINEATION REGIONAL ENGINEER
WALTER JOHNSON SIGNING & DELINEATION DESIGN ENGINEER

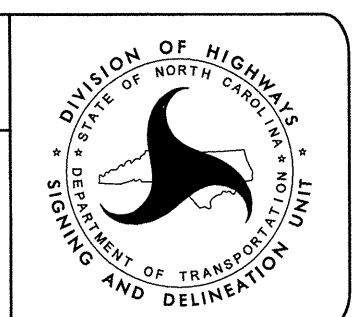

PLAN PREPARED BY:

BETSY L. WATSON, P.E. TRAFFIC ENGINEER
ROSI R. HENNEIN TRANSPORTATION TECHNICIAN



APPROVED: *RAW*
DATE: 3/8/12



STATE OF NORTH CAROLINA
DEPT. OF TRANSPORTATION
DIVISION OF HIGHWAYS
RALEIGH, N.C.

1-12

ENGLISH DETAIL DRAWING FOR
GROUND MOUNTED SIGN SUPPORTS

SHEET 2 OF 3
903D10

BEAM SHAPE	BOLT SIZE	SLIP BASE PLATE DATA							KEEPER PLATE DATA							HINGE CONNECTION DATA							BREAK AWAY SUPPORT WEIGHT CONSTANT LBS.			
		A ₁	B ₁	C ₁	D ₁	E ₁	T ₁	R ₁	A ₂	B ₂	C ₂	D ₂	E ₂	R ₂	T ₂	BOLT SIZE	F	G	H	I	J	K		L	R ₃	T ₃
S3X5.7	1/2"DIA. X 3"	7"	4"	1"	3/4"	2 1/2"	1"	9/32"	7"	4"	1"	3/4"	2 1/2"	9/32"	28 GAUGE	1/2"DIA. X 1 1/4"	2 1/4"	3 1/2"	4"	1 1/2"	1"	1 1/2"	2"	9/32"	3/8"	18
S4X7.7	1/2"DIA. X 3"	8"	4"	1"	3/4"	2 1/2"	1"	9/32"	8"	4"	1"	3/4"	2 1/2"	9/32"	28 GAUGE	1/2"DIA. X 1 1/4"	2 5/8"	3 1/2"	4"	1 1/2"	1"	1 1/2"	2"	9/32"	3/8"	20
W6X9	1/2"DIA. X 3"	10"	5"	1"	3/4"	3 1/2"	1"	9/32"	10"	5"	1"	3/4"	3 1/2"	9/32"	28 GAUGE	1/2"DIA. X 1 1/4"	4"	3 1/2"	4"	3/4"	1"	1 1/2"	2"	9/32"	3/8"	32
W6X12	5/8"DIA. X 3 3/4"	11"	5"	1 1/4"	7/8"	3 1/4"	1 1/4"	1 1/32"	11"	5"	1 1/4"	7/8"	3 1/4"	1 1/32"	28 GAUGE	5/8"DIA. X 2 1/4"	4"	4"	4 1/2"	3/4"	1 1/8"	5/8"	2 1/4"	1 1/32"	3/8"	39
W6X16	5/8"DIA. X 3 3/4"	12"	6"	1 1/4"	7/8"	4 1/4"	1 1/2"	1 1/32"	12"	6"	1 1/4"	7/8"	4 1/4"	1 1/32"	28 GAUGE	5/8"DIA. X 2 1/2"	4"	4"	4 1/2"	3/4"	1 1/8"	5/8"	2 1/4"	1 1/32"	1/2"	47
W8X18	5/8"DIA. X 4 1/4"	13 1/2"	6 1/2"	1 1/4"	7/8"	4 3/4"	1 1/2"	1 1/32"	13 1/2"	6 1/2"	1 1/4"	7/8"	4 3/4"	1 1/32"	28 GAUGE	5/8"DIA. X 2 1/2"	5 1/4"	4"	4 1/2"	1"	1 1/8"	5/8"	2 1/4"	1 1/32"	1/2"	70
W8X21	3/4"DIA. X 4 1/4"	14"	7"	1 1/2"	1"	5"	1 1/2"	1 1/32"	14"	7"	1 1/2"	1"	5"	1 1/32"	28 GAUGE	3/4"DIA. X 2 3/4"	5 1/4"	6"	7"	1"	1 3/4"	3/4"	3 1/2"	1 1/32"	1/2"	73
W10X22	3/4"DIA. X 4 1/4"	16"	8"	1 1/2"	1"	6"	1 1/2"	1 1/32"	16"	8"	1 1/2"	1"	6"	1 1/32"	28 GAUGE	3/4"DIA. X 2 3/4"	5 3/4"	6"	7"	1"	1 3/4"	3/4"	3 1/2"	1 1/32"	1/2"	119
W10X26	3/4"DIA. X 4 3/4"	16 1/2"	8"	1 1/2"	1"	6"	1 3/4"	1 1/32"	16 1/2"	8"	1 1/2"	1"	6"	1 1/32"	28 GAUGE	3/4"DIA. X 2 3/4"	5 3/4"	6"	7"	1"	1 3/4"	3/4"	3 1/2"	1 1/32"	5/8"	140
W12X26	3/4"DIA. X 4 3/4"	18 1/2"	9"	1 1/2"	1"	7"	1 3/4"	1 1/32"	18 1/2"	9"	1 1/2"	1"	7"	1 1/32"	28 GAUGE	3/4"DIA. X 2 3/4"	6 1/2"	6"	7"	1"	1 3/4"	3/4"	3 1/2"	1 1/32"	5/8"	176
W14X30	1"DIA. X 5"	22"	9"	2"	1 1/2"	6"	2"	1 1/32"	22"	9"	2"	1 1/2"	6"	1 1/32"	28 GAUGE	1"DIA. X 3"	6 3/4"	7"	8"	1 1/4"	2"	1"	4"	1 1/32"	5/8"	205
W16X31	1"DIA. X 5"	24"	9"	2"	1 1/2"	6"	2"	1 1/32"	24"	9"	2"	1 1/2"	6"	1 1/32"	28 GAUGE	1"DIA. X 3 1/4"	5 1/2"	7"	8"	1 1/4"	2"	1"	4"	1 1/32"	3/4"	223
W18X35	1"DIA. X 5"	25"	9"	2"	1 1/2"	6"	2"	1 1/32"	25"	9"	2"	1 1/2"	6"	1 1/32"	28 GAUGE	1"DIA. X 3 1/4"	6"	7"	8"	1 1/4"	2"	1"	4"	1 1/32"	3/4"	243
W18X40	1"DIA. X 5 1/2"	26"	9"	2"	1 1/2"	6"	2 1/4"	1 1/32"	26"	9"	2"	1 1/2"	6"	1 1/32"	28 GAUGE	1"DIA. X 3 3/4"	6"	7"	8"	1 1/4"	2"	1"	4"	1 1/32"	7/8"	278
W21X44	1"DIA. X 5 1/2"	29"	9"	2"	1 1/2"	6"	2 1/2"	1 1/32"	29"	9"	2"	1 1/2"	6"	1 1/32"	28 GAUGE	1"DIA. X 3 3/4"	6 1/2"	7"	8"	1 1/4"	2"	1"	4"	1 1/32"	7/8"	310

2" FLAT TURNS
TOP AND BOTTOM
(SEE NOTE 10)

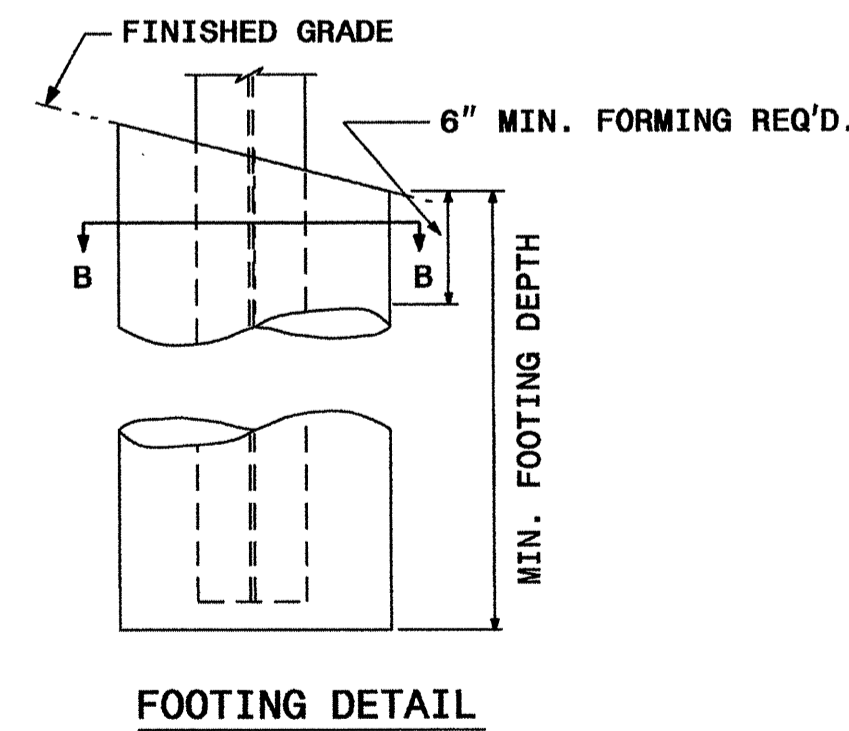
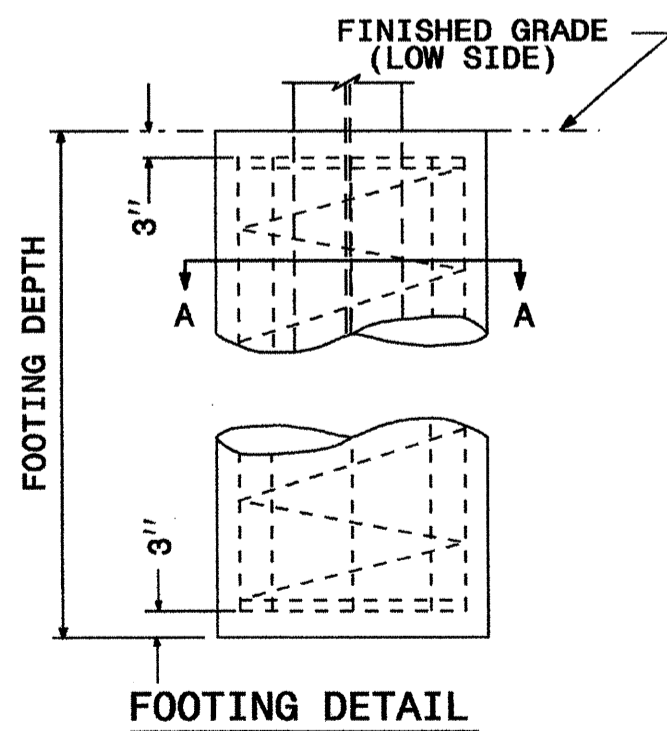
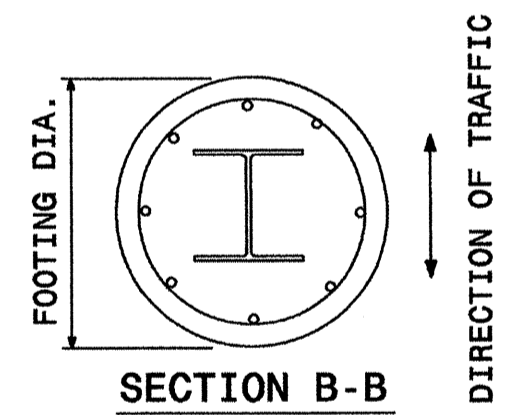
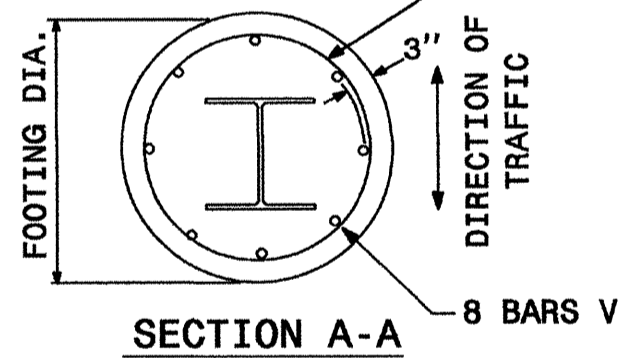

FOUNDATION DATA *		
FOOTING DIAMETER	REINFORCEMENT	SPIRAL BAR
1' 6"	8 # 6 BARS	#3 BAR, 6" PITCH
2'	8 # 7 BARS	#3 BAR, 6" PITCH
2' 6"	8 # 9 BARS	#3 BAR, 6" PITCH
3'	8 # 11 BARS	#3 BAR, 6" PITCH
3' 6"	8 # 12 BARS	#3 BAR, 6" PITCH
4'	8 # 14 BARS	#3 BAR, 6" PITCH

* FOUNDATION DIMENSIONS ARE SHOWN IN PLANS

STATE OF NORTH CAROLINA
DEPT. OF TRANSPORTATION
DIVISION OF HIGHWAYS
RALEIGH, N.C.

1-12

ENGLISH DETAIL DRAWING FOR
GROUND MOUNTED SIGN SUPPORTS

SHEET 2 OF 3
903D10

REVISED SIGNING
ROADWAY STANDARD DRAWING

APPROVED: *Betsy L. Watson*

DATE: 4/22/13

SEAL



Stantec
 Stantec Consulting Services Inc.
 801 Jones Franklin Road
 Suite 300
 Raleigh, NC 27606
 Tel. (919) 851-6866
 Fax. (919) 851-7024
 www.stantec.com
 License No. F-0672

SUPPORT CHART

SIGN NO.	SIGN TYPE	SIGN SIZE (in.)			ROADWAY STATION	NO. OF SUP.	BEAM SECTION	SUPPORT TYPE BA or S	ATTACH METHOD	MOUNTING METHOD	HORIZ. CLR.* (ft.)	LENGTH (ft)			LEFT SUPPORT (ft)			CENTER SUPPORT (ft)			RIGHT SUPPORT (ft)			FOOTING DIAMETER (ft.)	FOOTING DEPTH (ft.)	B/A SUPPORT WEIGHTS (lbs.)	SIMPLE SUPPORT WEIGHTS (lbs.)	REINF. FTGS. (c.y.)	PLAIN FTGS. (c.y.)	FIELD VERIFIED SEE NOTE 2 (mm/dd/yy)															
		w	x	h								SNS HT H	MTG HT C	EMBED-MENT	S	L	TOTAL LENGTH	S	L	TOTAL LENGTH	S	L	TOTAL LENGTH																						
101	A	126	X	162	-L- STA 15+25	2	W6x16	BA	N/A	N/A	18.00	13.50	7.00	6	1.00	21.50	27.50	0.00	0.00	0.00	2.00	22.50	28.50	1.5	6.5	1028.38	0.00	0.85	0.00																
102	A	102	X	84	-L- STA 18+20	2	W6x12	BA	N/A	N/A	18.00	7.00	7.00	4	1.00	15.00	19.00	0.00	0.00	0.00	3.40	17.40	21.40	1.5	4.5	570.16	0.00	0.59	0.00																
103	A	102	X	84	-L- STA 21+40	2	W6x9	S	N/A	N/A	18.00	7.00	7.00	4	0.40	14.40	18.40	0.00	0.00	0.00	2.00	16.00	20.00	1.5	4.5	0.00	345.60	0.59	0.00																
104	A	114	X	102	-L- STA 24+60	2	W6x12	BA	N/A	N/A	18.00	8.50	7.00	4.5	0.70	16.20	20.70	0.00	0.00	0.00	2.50	18.00	22.50	1.5	5	603.76	0.00	0.65	0.00																
105	A	126	X	162	-L- STA 29+10	2	W6x16	BA	N/A	N/A	18.00	13.50	7.00	5.5	1.50	22.00	27.50	0.00	0.00	0.00	3.10	23.60	29.10	1.5	6	1037.98	0.00	0.79	0.00																
106	A	114	X	102	-L- STA 27+75	2	W6x12	BA	N/A	N/A	18.00	8.50	7.00	4.5	0.60	16.10	20.60	0.00	0.00	0.00	2.40	17.90	22.40	1.5	5	601.36	0.00	0.65	0.00																
107	A	108	X	150	-Y1- STA 11+80	2	W6x16	BA	N/A	N/A	18.00	12.50	7.00	5.5	3.70	23.20	28.70	0.00	0.00	0.00	5.50	25.00	30.50	1.5	6	1079.58	0.00	0.79	0.00																
901	B	90	X	48	-RPB- 12+30	2	S3x5.7	BA	N/A	N/A	18.00	4.00	7.00	3.5	2.00	13.00	16.50	0.00	0.00	0.00	2.70	13.70	17.20	1	4	227.62	0.00	0.00	0.23																
902	A	90	X	72	-RPB- STA 13+35	2	W6x9	BA	N/A	N/A	18.00	6.00	7.00	3.5	2.30	15.30	18.80	0.00	0.00	0.00	3.30	16.30	19.80	1.5	4	410.52	0.00	0.52	0.00																
903	A	90	X	72	-RPB- STA 13+55	2	S4x7.7	BA	N/A	N/A	18.00	6.00	7.00	4	2.00	15.00	19.00	0.00	0.00	0.00	2.70	15.70	19.70	1.00	4.5	338.60	0.00	0.00	0.26																
904	A	90	X	72	-RPB- STA 15+40	2	W6x9	BA	N/A	N/A	18.00	6.00	7.00	4	2.90	15.90	19.90	0.00	0.00	0.00	4.20	17.20	21.20	1.50	4.5	433.02	0.00	0.59	0.00																
905	A	90	X	72	-RPD- STA 16+50	2	S4x7.7	BA	N/A	N/A	18.00	6.00	7.00	4	1.50	14.50	18.50	0.00	0.00	0.00	2.00	15.00	19.00	1.00	4.5	329.36	0.00	0.00	0.26																
906	A	90	X	72	-RPD- STA 16+80	2	S4x7.7	BA	N/A	N/A	18.00	6.00	7.00	4	2.00	15.00	19.00	0.00	0.00	0.00	2.70	15.70	19.70	1.00	4.5	338.60	0.00	0.00	0.26																
907	A	90	X	72	-RPD- STA 18+60	2	S4x7.7	BA	N/A	N/A	18.00	6.00	7.00	4	1.90	14.90	18.90	0.00	0.00	0.00	2.50	15.50	19.50	1.00	4.5	336.29	0.00	0.00	0.26																
																							TOTAL	7335.24	TOTAL	345.60	TOTAL	6.02	TOTAL	1.28											USE:	7336	346	7	2

NOTES

- DIMENSION "S" REPRESENTS AN INCREASE (+), OR A DECREASE (-) IN POLE LENGTH, RELATIVE TO THE ELEVATION OF THE EDGE OF PAVEMENT.
- FIELD VERIFICATIONS SHALL BE REQUIRED FOR ALL SUPPORTS, SEE (*) ARTICLE 903-3. FABRICATORS SHALL BE AISC CERTIFIED IN CATEGORY 1, SEE (*) ARTICLE 1072-1. (*) = N.C.D.O.T. STANDARD SPECIFICATIONS FOR ROADS AND STRUCTURES
- PLAN LOCATIONS FOR EXISTING UTILITIES ARE BASED ON THE BEST AVAILABLE INFORMATION AND, THEREFORE MAY NOT BE PRECISELY ACCURATE. THEREFORE, IT IS INCUMBENT UPON THE CONTRACTOR TO DETERMINE THE EXACT LOCATION OF UTILITIES BEFORE BEGINNING WORK IN A LOCATION.

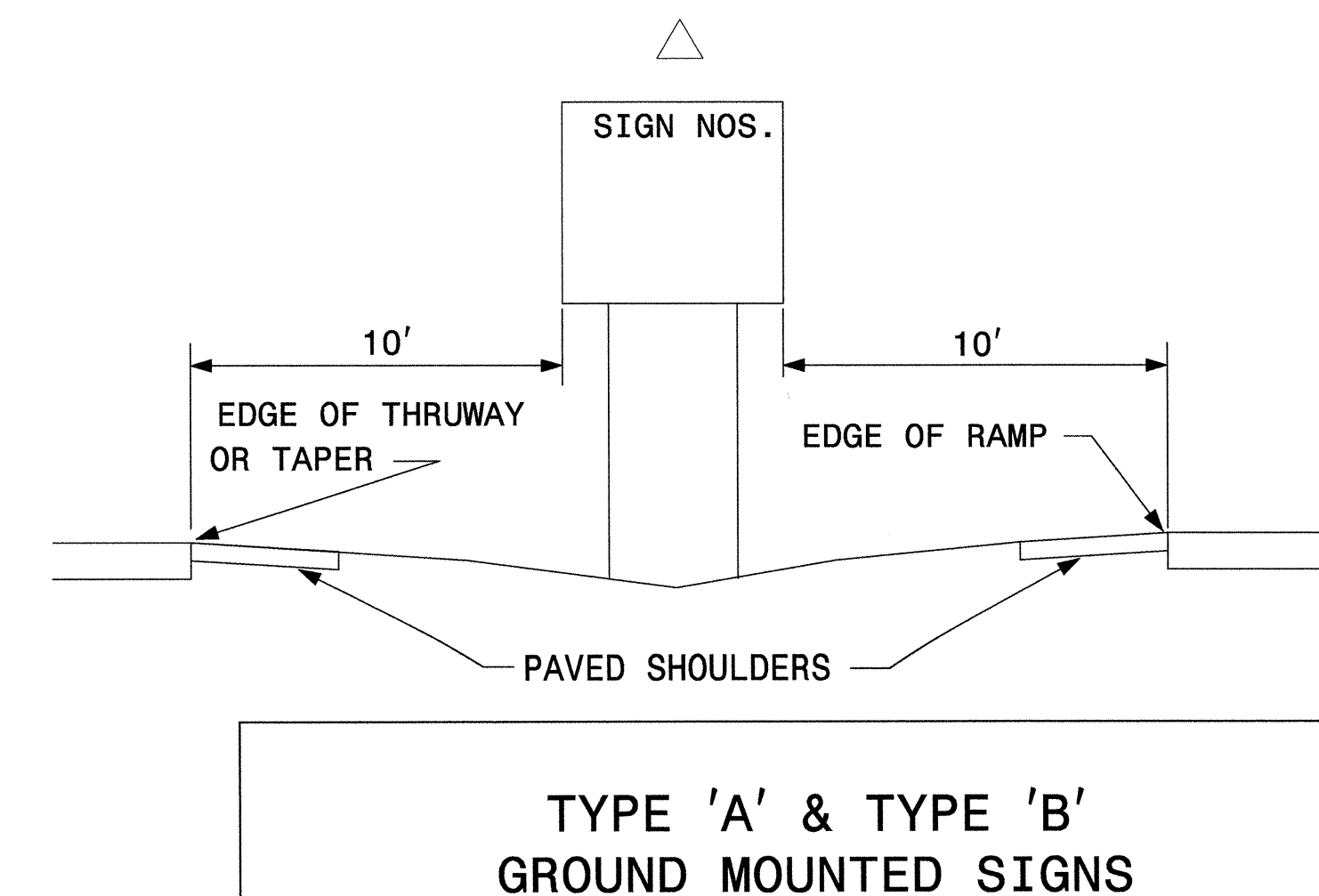
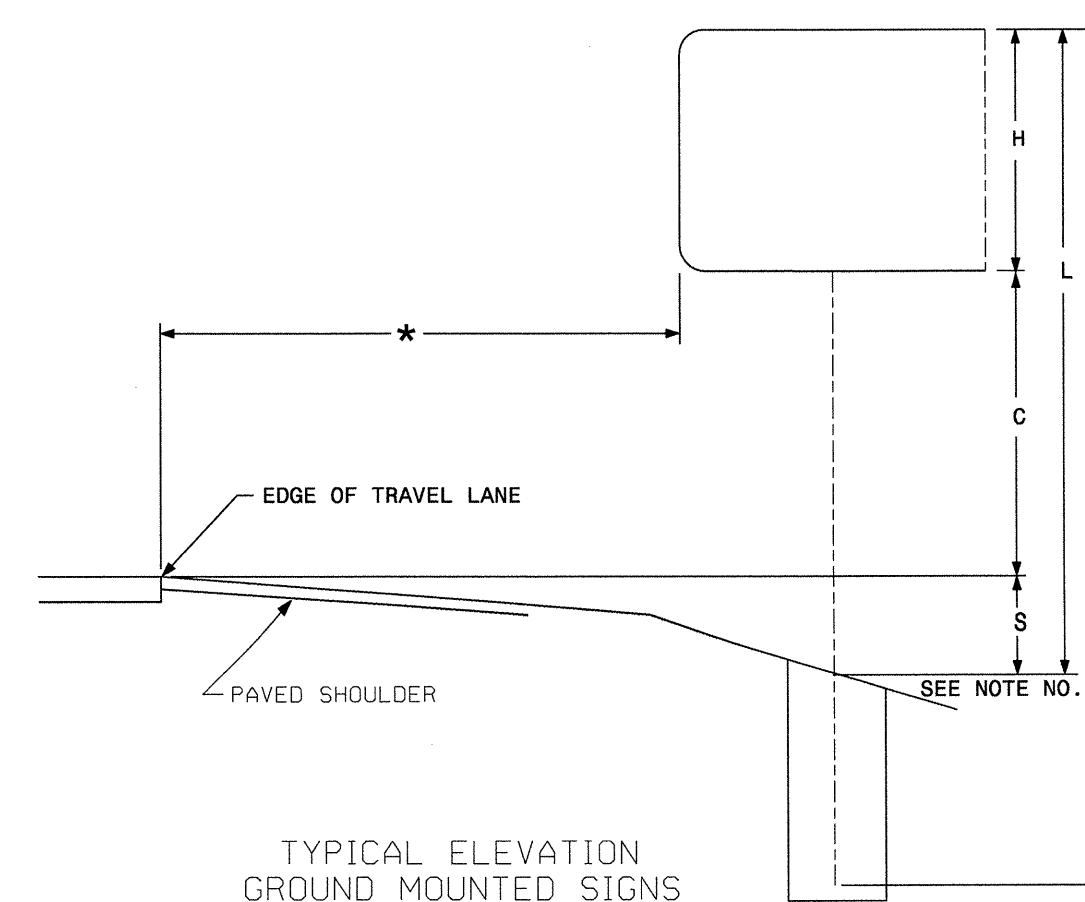

APPROVED: *Betsy L. Watson*

DATE: 4/22/13

SEAL

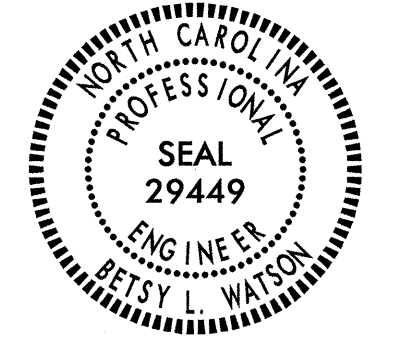

Stantec
Stantec Consulting Services Inc.
801 Jones Franklin Road
Suite 300
Raleigh, NC 27606
Tel. (919) 851-8866
Fax. (919) 851-7024
www.stantec.com
License No. F-0672

401 QUANTITY REQ'D 1

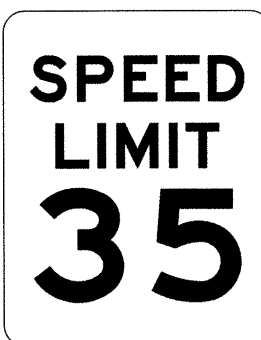

24 X 30
R2-1

ONE "U" POST PER SIGN

406 QUANTITY REQ'D 7



36 X 36
R5-1

ONE "U" POST PER SIGN

411 QUANTITY REQ'D 2

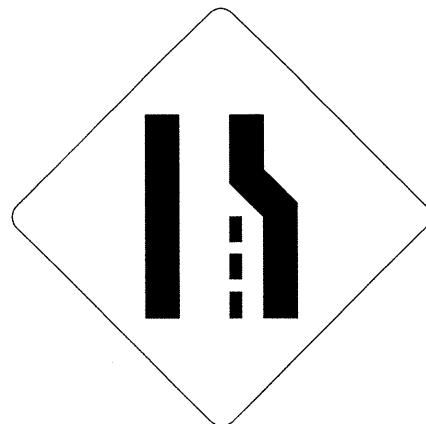

36 X 36
W4-2R

ONE "U" POST PER SIGN

416 QUANTITY REQ'D 4



36 X 36
W11-2

FLUORESCENT YELLOW/GREEN
ONE "U" POST PER SIGN

421 QUANTITY REQ'D 2

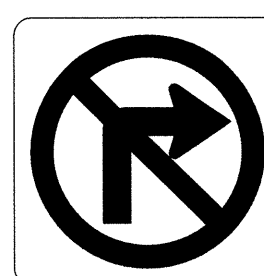

36 X 36
R3-1

ONE "U" POST PER SIGN

402 QUANTITY REQ'D 2



36 X 36
R3-7R

ONE "U" POST PER SIGN

407 QUANTITY REQ'D 4

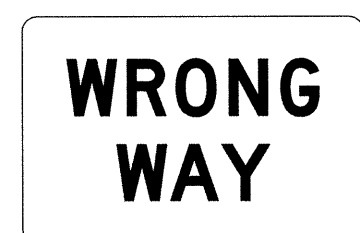

42 X 30
R5-1a

ONE "U" POST PER SIGN

412 QUANTITY REQ'D 2



36 X 12
R6-1R

MOUNT ABOVE SIGN 409
IN 2 INSTALLATIONS

417 QUANTITY REQ'D 2



30 X 18
W16-7pR

FLUORESCENT YELLOW/GREEN
MOUNT BELOW SIGN 416
IN 2 INSTALLATIONS

422 QUANTITY REQ'D 2

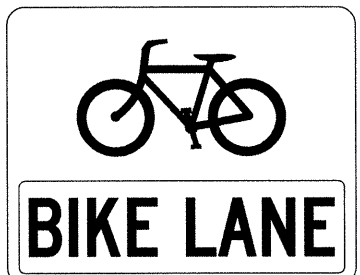

30 X 24
R3-17

ONE "U" POST PER SIGN

403 QUANTITY REQ'D 2



36 X 36
R3-7L

ONE "U" POST PER SIGN

408 QUANTITY REQ'D 2

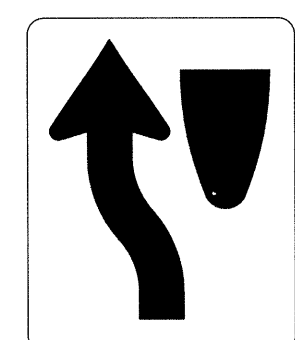

24 X 30
R4-8

ONE "U" POST PER SIGN

413 QUANTITY REQ'D 6



54 X 18
R6-1L

TWO "U" POSTS PER SIGN

418 QUANTITY REQ'D 2



30 X 18
W16-7pL

FLUORESCENT YELLOW/GREEN
MOUNT BELOW SIGN 416
IN 2 INSTALLATIONS

423 QUANTITY REQ'D 1

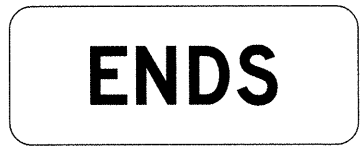

30 X 12
R3-17b

MOUNT BELOW SIGN 422
IN 1 INSTALLATION

404 QUANTITY REQ'D 4

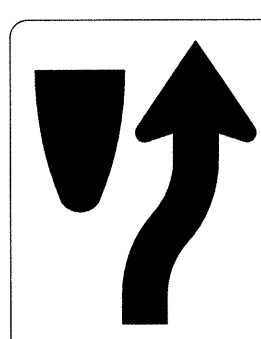

24 X 30
R4-7

ONE "U" POST PER SIGN

409 QUANTITY REQ'D 2

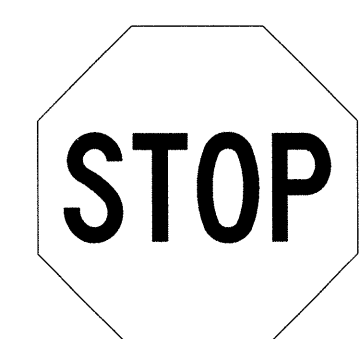

30 X 30
R1-1

ONE "U" POST PER SIGN

414 QUANTITY REQ'D 2

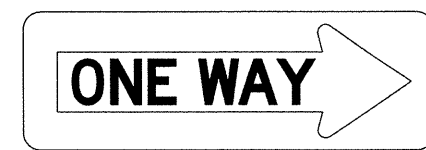

54 X 18
R6-1R

MOUNT BEHIND SIGN 413
IN 2 INSTALLATIONS

419 QUANTITY REQ'D 4



36 X 36
R3-2

MOUNT BEHIND SIGN 406
IN 2 INSTALLATIONS
ONE "U" POST PER SIGN

405 QUANTITY REQ'D 6

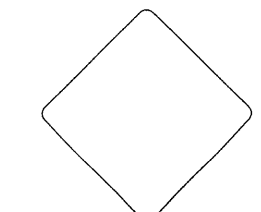

18 X 18
OM1-3

MOUNT BELOW SIGN 404
IN 4 INSTALLATIONS
MOUNT BELOW SIGN 408
IN 2 INSTALLATIONS

410 QUANTITY REQ'D 2

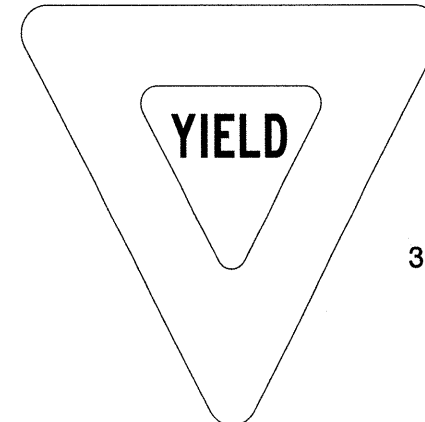

36 X 36 X 36
R1-2

ONE "U" POST PER SIGN

415 QUANTITY REQ'D 4

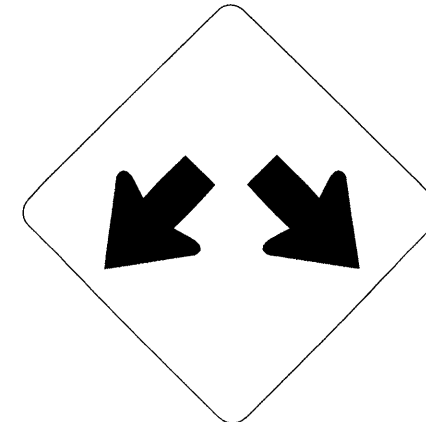

36 X 36
W12-1

ONE "U" POST PER SIGN

420 QUANTITY REQ'D 2

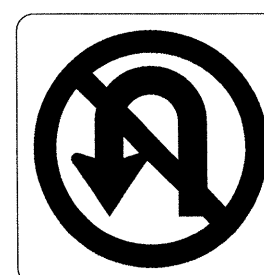

36 X 36
R3-4

MOUNT BEHIND SIGN 404
IN 2 INSTALLATIONS

TYPE 'E' SIGNS

4/21/2013 10:41:00 AM C:\Users\frheinlein\Documents\CADD\Signing_Layout_Plans\I-4733_sign_sheets\I-5.dgn

APPROVED: *Betsy L. Watson*

DATE: 4/22/13

SEAL

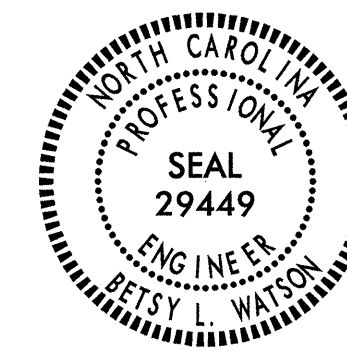

Stantec
Stantec Consulting Services Inc.
801 Jones Franklin Road
Suite 300
Raleigh, NC 27606
Tel. (919) 851-6866
Fax. (919) 851-7024
www.stantec.com
License No. F-0672

501 506

TWO "U" POSTS PER SIGN

507

TWO "U" POSTS PER SIGN

502

TWO "U" POSTS PER SIGN

508

MOUNT BEHIND SIGN 504
IN 1 INSTALLATION

503

MOUNT BELOW SIGN 301
IN 1 INSTALLATION

509

MOUNT BELOW SIGN 303
IN 1 INSTALLATION

504

TWO "U" POSTS PER SIGN

510

TWO "U" POSTS PER SIGN

505

MOUNT BELOW SIGN 302
IN 1 INSTALLATION

511

ONE "U" POST PER SIGN

TYPE 'F' SIGNS

SIGN NUMBER: 101
 TYPE: A
 QUANTITY: 1
 SIGN WIDTH: 126"
 HEIGHT: 162"
 TOTAL AREA: 141.8 Sq.Ft.
 BORDER TYPE: FLUSH
 RADII: 12"
 WIDTH: 2"
 RECESS: 0"
 NO. Z BARS: 4
 LENGTH: 118.0

BACKG COLOR: Green
 COPY COLOR: White

SYMBOL	X	Y	WID	HT
M1_1	25.1	112.5	24	24
M1_4	76.9	112.5	24	24
M1_1	26.1	41.9	24	24

MAT'L: 0.125" (3.2MM) ALUMINUM

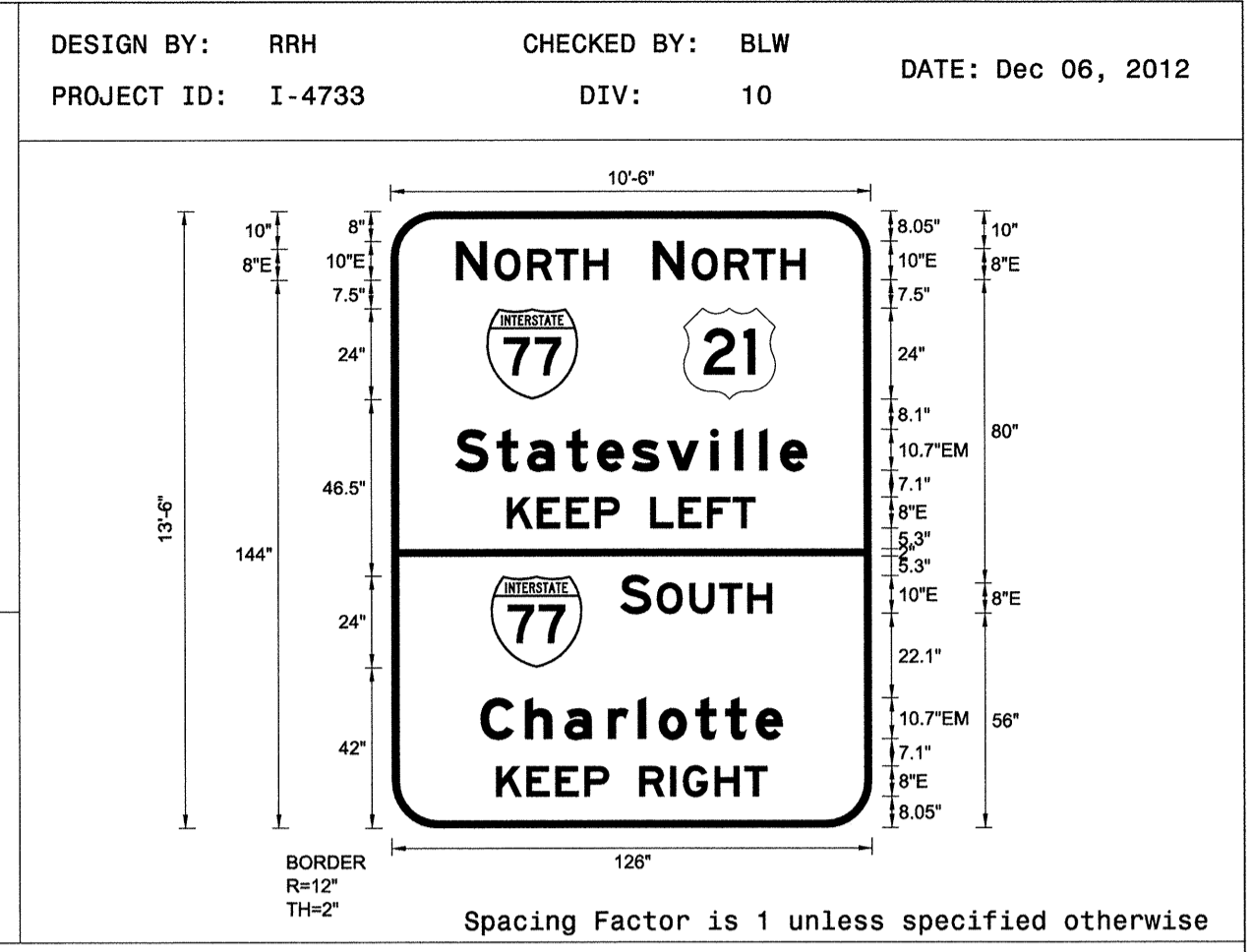

USE NOTES

- Legend and border (except those that are colored black) shall be direct applied Grade C sheeting.
- Background shall be Grade C reflective sheeting.
- Shields; A, B, and C type arrows shall be on 0.032" (0.8mm) aluminum and demountable.

LETTER POSITIONS

Letter spacings are to start of next letter

	N	O	R	T	H																Series/Size Text Length
17.1	8.1	2.1	8.6	7.4	7.4	6.5	68.9														E 2000
	N	O	R	T	H																E 2000
68.9	8.1	2.1	8.6	7.4	7.4	6.5	17.1														40
	S	t	a	t	e	s	v	i	l	l	e										EM 2000
16.8	10.9	8	10.3	8	9.2	9.2	11.3	6.4	6.4	5.5	7.1	16.8									92.3
	K	E	E	P	L	E	F	T													E 2000
30.4	7.9	7.6	7.6	6.5	8	7.4	7.6	6.6	6	30.4											65.2
	S	O	U	T	H																E 2000
60.1	8.1	1.5	8.6	7.8	7.4	6.5	26.1														39.8
	C	h	a	r	l	o	t	t	e												EM 2000
23.4	11.7	10.4	11.3	7.9	5.5	9.5	7.9	8	7.1	23.4											79.3
	K	E	E	P	R	I	G	H	T												E 2000
27.4	7.9	7.6	7.6	6.5	8	8.1	3.3	8.3	7.8	6	27.4										71.1

SIGN NUMBER: 103
 TYPE: A
 QUANTITY: 1
 SIGN WIDTH: 102"
 HEIGHT: 84"
 TOTAL AREA: 59.5 Sq.Ft.
 BORDER TYPE: FLUSH
 RADII: 9"
 WIDTH: 2"
 RECESS: 0"
 NO. Z BARS: 2
 LENGTH: 94.0

BACKG COLOR: Green
 COPY COLOR: White

SYMBOL	X	Y	WID	HT
M1_1	14.1	51.2	24	24
AR_Type A	36.6	6.1	18.3	28.7

MAT'L: 0.125" (3.2MM) ALUMINUM

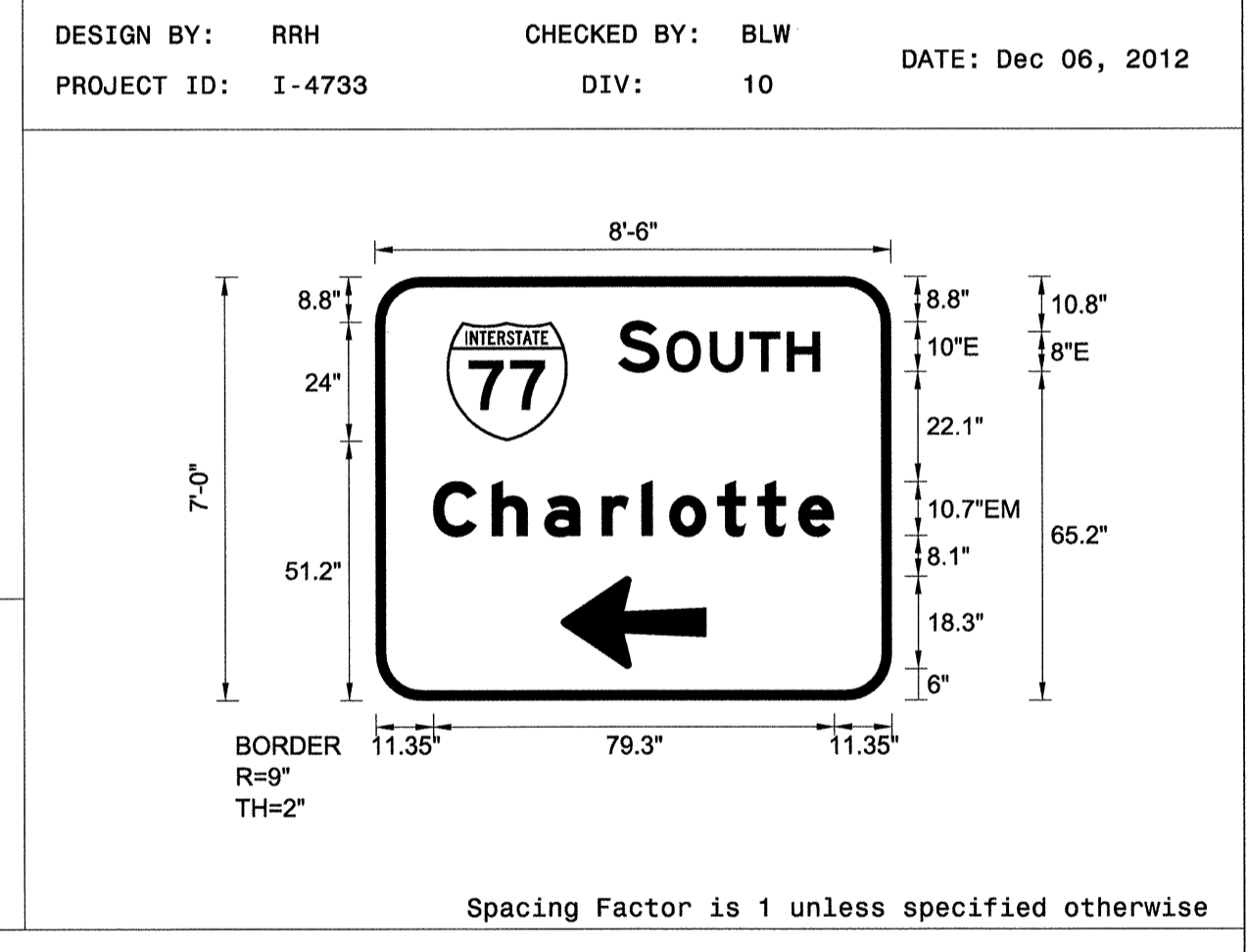

USE NOTES

- Legend and border (except those that are colored black) shall be direct applied Grade C sheeting.
- Background shall be Grade C reflective sheeting.
- Shields; A, B, and C type arrows shall be on 0.032" (0.8mm) aluminum and demountable.

LETTER POSITIONS

Letter spacings are to start of next letter

	S	O	U	T	H																Series/Size Text Length	
48.1	8.1	1.5	8.6	7.8	7.4	6.5	14.1														E 2000	
	C	h	a	r	l	o	t	t	e													EM 2000
11.4	11.7	10.4	11.3	7.9	5.5	9.5	7.9	8	7.1	11.4											79.3	

SIGN NUMBER: 102
 TYPE: A
 QUANTITY: 1
 SIGN WIDTH: 102"
 HEIGHT: 84"
 TOTAL AREA: 59.5 Sq.Ft.
 BORDER TYPE: FLUSH
 RADII: 9"
 WIDTH: 2"
 RECESS: 0"
 NO. Z BARS: 2
 LENGTH: 94.0

BACKG COLOR: Green
 COPY COLOR: White

SYMBOL	X	Y	WID	HT
M1_1	14.1	51.2	24	24
AR_Type A	36.6	6.1	18.3	28.7

MAT'L: 0.125" (3.2MM) ALUMINUM

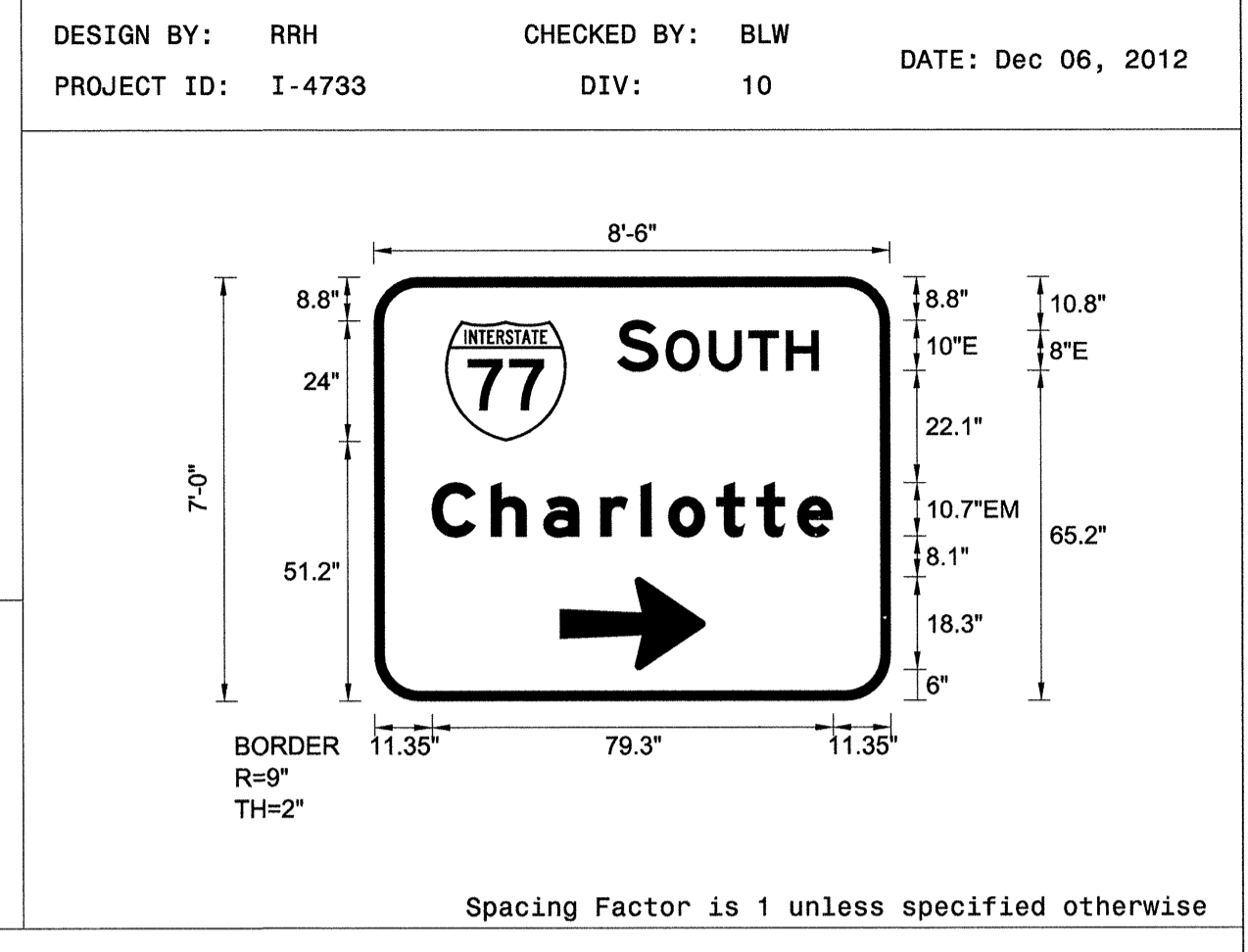

USE NOTES

- Legend and border (except those that are colored black) shall be direct applied Grade C sheeting.
- Background shall be Grade C reflective sheeting.
- Shields; A, B, and C type arrows shall be on 0.032" (0.8mm) aluminum and demountable.

LETTER POSITIONS

Letter spacings are to start of next letter

	S	O	U	T	H																Series/Size Text Length	
48.1	8.1	1.5	8.6	7.8	7.4	6.5	14.1														E 2000	
	C	h	a	r	l	o	t	t	e													EM 2000
11.4	11.7	10.4	11.3	7.9	5.5	9.5	7.9	8	7.1	11.4											79.3	

SIGN NUMBER: 104
 TYPE: A
 QUANTITY: 1
 SIGN WIDTH: 114"
 HEIGHT: 102"
 TOTAL AREA: 80.8 Sq.Ft.
 BORDER TYPE: FLUSH
 RADII: 12"
 WIDTH: 2"
 RECESS: 0"
 NO. Z BARS: 3
 LENGTH: 106.0

BACKG COLOR: Green
 COPY COLOR: White

SYMBOL	X	Y	WID	HT
M1_1	19.7	51.2	24	24
M1_4	70.3	51.2	24	24
AR_Type A	42.6	6	18.3	28.7

MAT'L: 0.125" (3.2MM) ALUMINUM

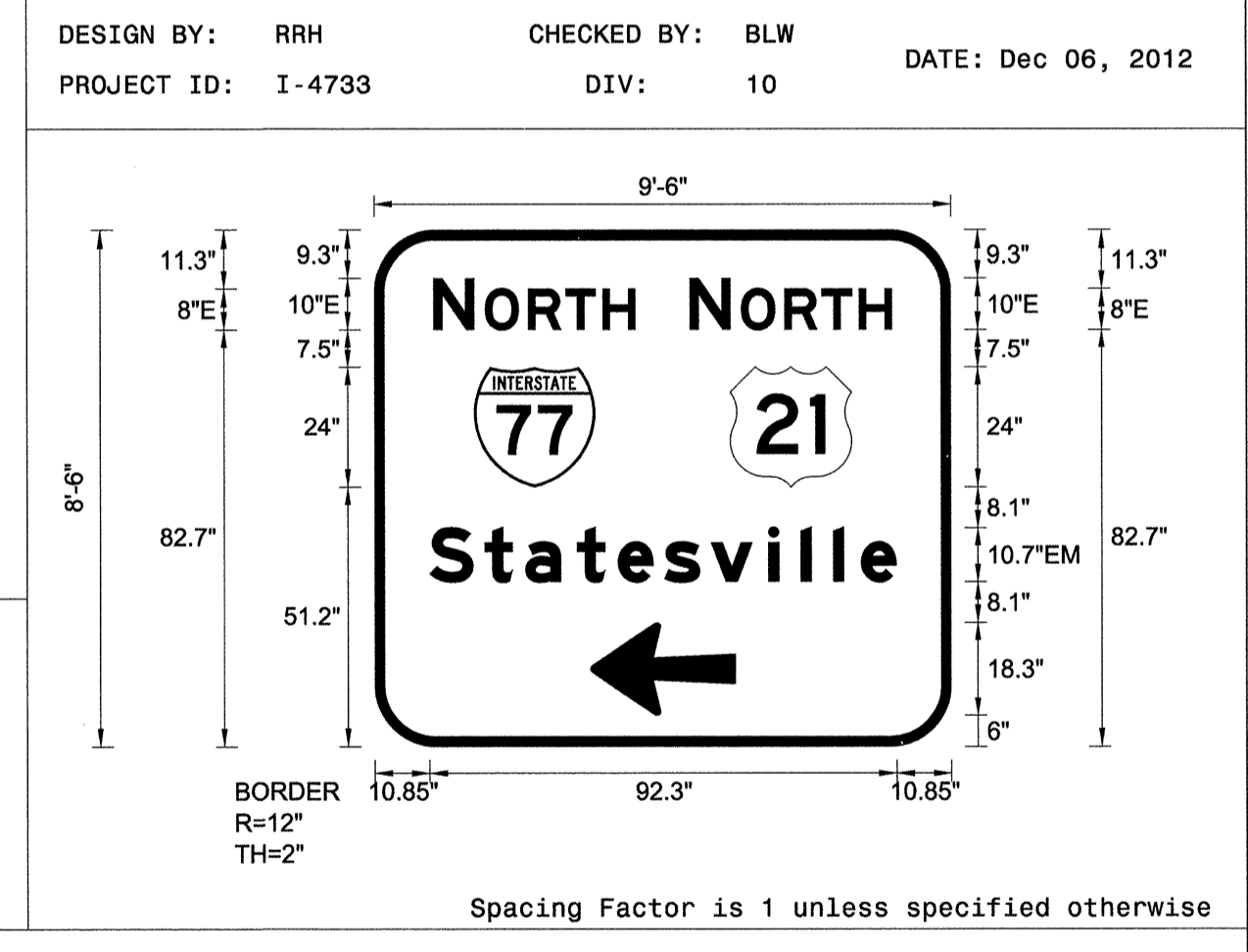

USE NOTES

- Legend and border (except those that are colored black) shall be direct applied Grade C sheeting.
- Background shall be Grade C reflective sheeting.
- Shields; A, B, and C type arrows shall be on 0.032" (0.8mm) aluminum and demountable.

LETTER POSITIONS

Letter spacings are to start of next letter

	N	O	R	T	H																Series/Size Text Length	
11.7	8.1	2.1	8.6	7.4	7.4	6.5	62.4														E 2000	
	N	O	R	T	H																	E 2000
62.4	8.1	2.1	8.6	7.4	7.4	6.5	11.7														40	
	S	t	a	t	e	s	v	i	l	l	e											EM 2000
10.8	10.9	8	10.3	8	9.2	9.2	11.3	6.4	6.4	5.5	7.1	10.8									92.3	

TIP NO. I-4733 SHEET NO. SIGN-4

APPROVED: *Betsy L. Watson*

DATE: 4/22/13

SEAL

Stantec Consulting Services Inc.
 801 Jones Franklin Road
 Suite 300
 Raleigh, NC 27606
 Tel. (919) 851-6866
 Fax. (919) 851-7024
 www.stantec.com
 License No. F-0672

TYPE 'A' SIGNS

4/21/2013 U:\Traffic\Signing\CADD\Signing\Layout_Plans\I-4733_s\sign_sheets I - 5.dgn

APPROVED: *Betsy L. Watson*

DATE: 4/22/13

SEAL

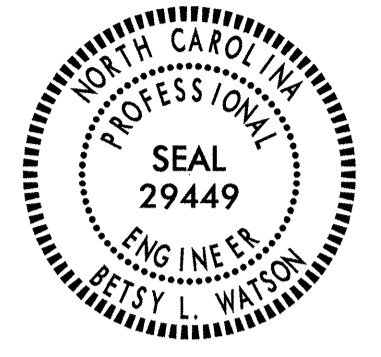

Stantec Consulting Services Inc.
801 Jones Franklin Road
Suite 300
Raleigh, NC 27606
Tel. (919) 851-6866
Fax. (919) 851-7024
www.stantec.com
License No. F-0672

SIGN NUMBER: 105
TYPE: A
QUANTITY: 1

BACKG COLOR: Green
COPY COLOR: White

SYMBOL	X	Y	WID	HT
M1_1	26.1	130	24	24
M1_1	25.1	42	24	24
M1_4	76.9	42	24	24

SIGN WIDTH: 126"
HEIGHT: 162"
TOTAL AREA: 141.8 Sq.Ft.

BORDER TYPE: FLUSH
RADI: 12"
WIDTH: 2"
RECESS: 0"

NO. Z BARS: 4
LENGTH: 118.0

MAT'L: 0.125" (3.2MM) ALUMINUM

DESIGN BY: RRH CHECKED BY: BLW
PROJECT ID: I-4733 DIV: 10 DATE: Dec 06, 2012

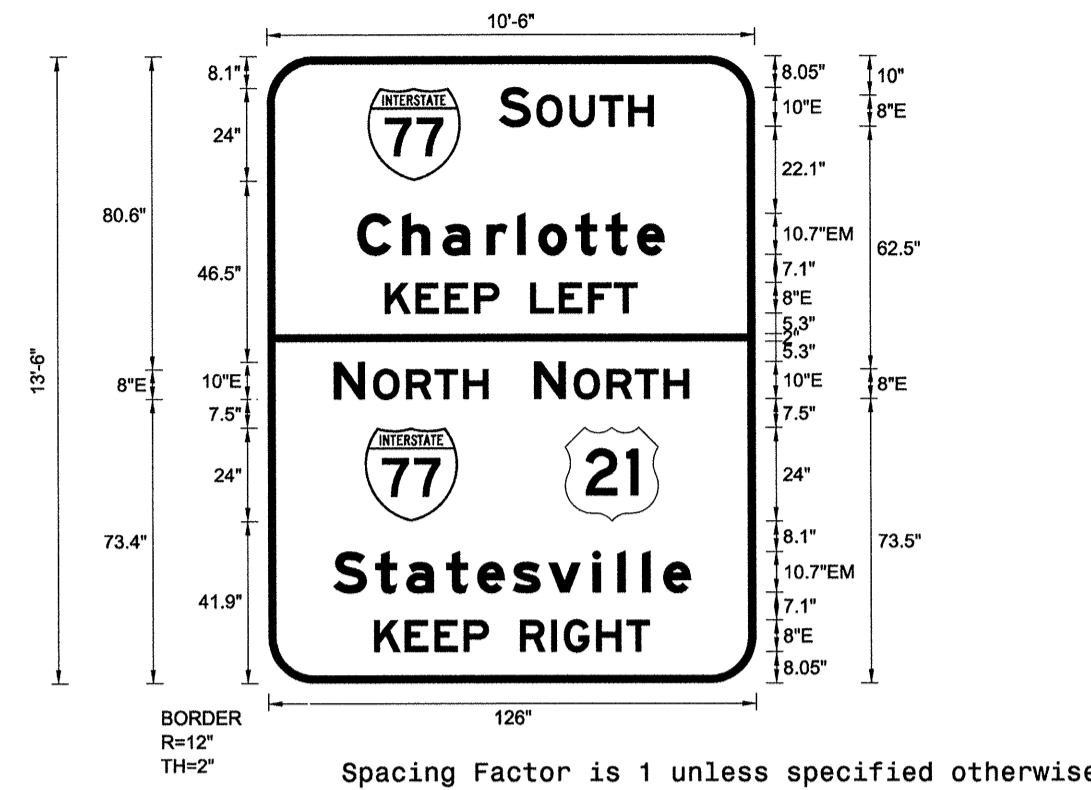

- USE NOTES
- Legend and border (except those that are colored black) shall be direct applied Grade C sheeting.
 - Background shall be Grade C reflective sheeting.
 - Shields; A, B, and C type arrows shall be on 0.032" (0.8mm) aluminum and demountable.

LETTER POSITIONS

Letter spacings are to start of next letter

	S	O	U	T	H						Series/Size Text Length	
60.1	8.1	1.5	8.6	7.8	7.4	6.5	26.1				E 2000	
	C	h	a	r	l	o	t	t	e		EM 2000	
23.4	11.7	10.4	11.3	7.9	5.5	9.5	7.9	8	7.1	23.4	79.3	
	K	E	E	P	L	E	F	T			E 2000	
30.4	7.9	7.6	7.6	6.5	8	7.4	7.6	6.6	6	30.4	65.2	
	N	O	R	T	H						E 2000	
17.1	8.1	2.1	8.6	7.4	7.4	6.5	68.9				40	
	N	O	R	T	H						E 2000	
68.9	8.1	2.1	8.6	7.4	7.4	6.5	17.1				40	
	S	t	a	t	e	s	v	i	l	l	e	EM 2000
16.8	10.9	8	10.3	8	9.2	9.2	11.3	6.4	6.4	5.5	7.1	16.8
	K	E	E	P	R	I	G	H	T		E 2000	
27.4	7.9	7.6	7.6	6.5	8	8.1	3.3	8.3	7.8	6	27.4	

SIGN NUMBER: 106
TYPE: A
QUANTITY: 1

BACKG COLOR: Green
COPY COLOR: White

SYMBOL	X	Y	WID	HT
M1_1	19.7	51.2	24	24
M1_4	70.3	51.2	24	24
AR_Type A	42.6	6	18.3	28.7

SIGN WIDTH: 114"
HEIGHT: 102"
TOTAL AREA: 80.8 Sq.Ft.

BORDER TYPE: FLUSH
RADI: 12"
WIDTH: 2"
RECESS: 0"

NO. Z BARS: 3
LENGTH: 106.0

MAT'L: 0.125" (3.2MM) ALUMINUM

DESIGN BY: RRH CHECKED BY: BLW
PROJECT ID: I-4733 DIV: 10 DATE: Dec 06, 2012

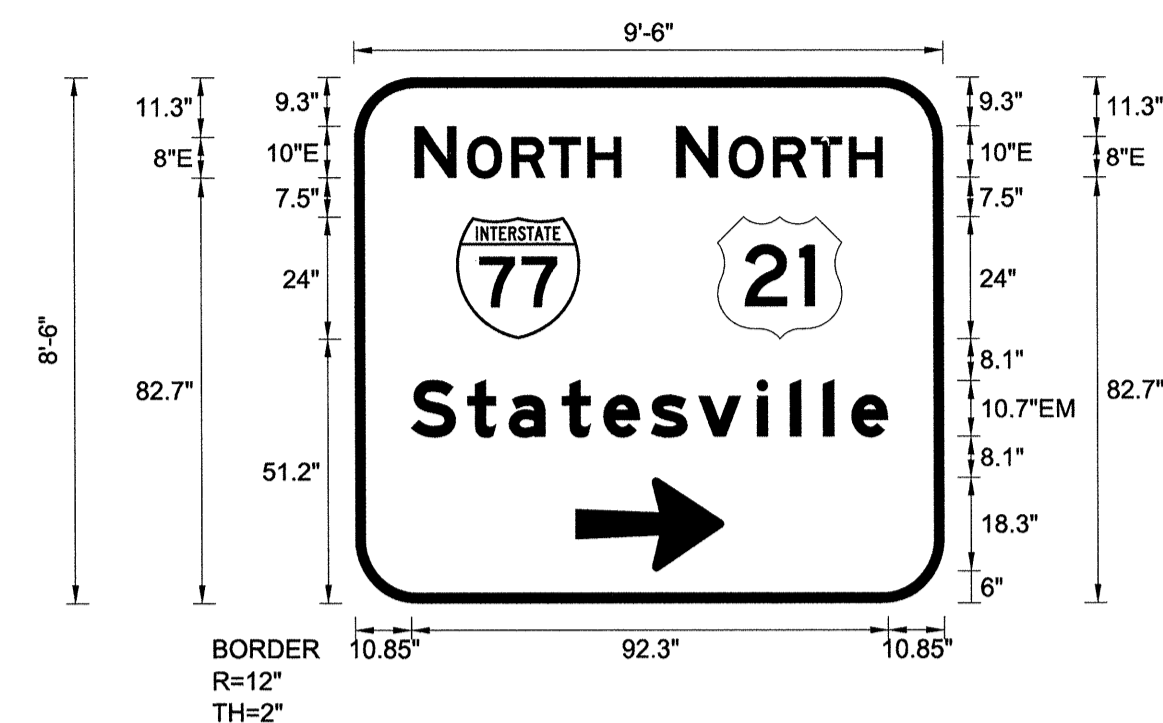

- USE NOTES
- Legend and border (except those that are colored black) shall be direct applied Grade C sheeting.
 - Background shall be Grade C reflective sheeting.
 - Shields; A, B, and C type arrows shall be on 0.032" (0.8mm) aluminum and demountable.

LETTER POSITIONS

Letter spacings are to start of next letter

	N	O	R	T	H						Series/Size Text Length	
11.7	8.1	2.1	8.6	7.4	7.4	6.5	62.4				E 2000	
	N	O	R	T	H						E 2000	
62.4	8.1	2.1	8.6	7.4	7.4	6.5	11.7				40	
	S	t	a	t	e	s	v	i	l	l	e	EM 2000
10.8	10.9	8	10.3	8	9.2	9.2	11.3	6.4	6.4	5.5	7.1	10.8

SIGN NUMBER: 107
TYPE: A
QUANTITY: 1

BACKG COLOR: Green
COPY COLOR: White

SYMBOL	X	Y	WID	HT
M1_1	16.1	86.7	24	24
M1_4	67.9	86.7	24	24
M1_1	17.1	21	24	24

SIGN WIDTH: 108"
HEIGHT: 150"
TOTAL AREA: 112.5 Sq.Ft.

BORDER TYPE: FLUSH
RADI: 12"
WIDTH: 2"
RECESS: 0"

NO. Z BARS: 4
LENGTH: 100.0

MAT'L: 0.125" (3.2MM) ALUMINUM

DESIGN BY: RRH CHECKED BY: BLW
PROJECT ID: I-4733 DIV: 10 DATE: Dec 06, 2012

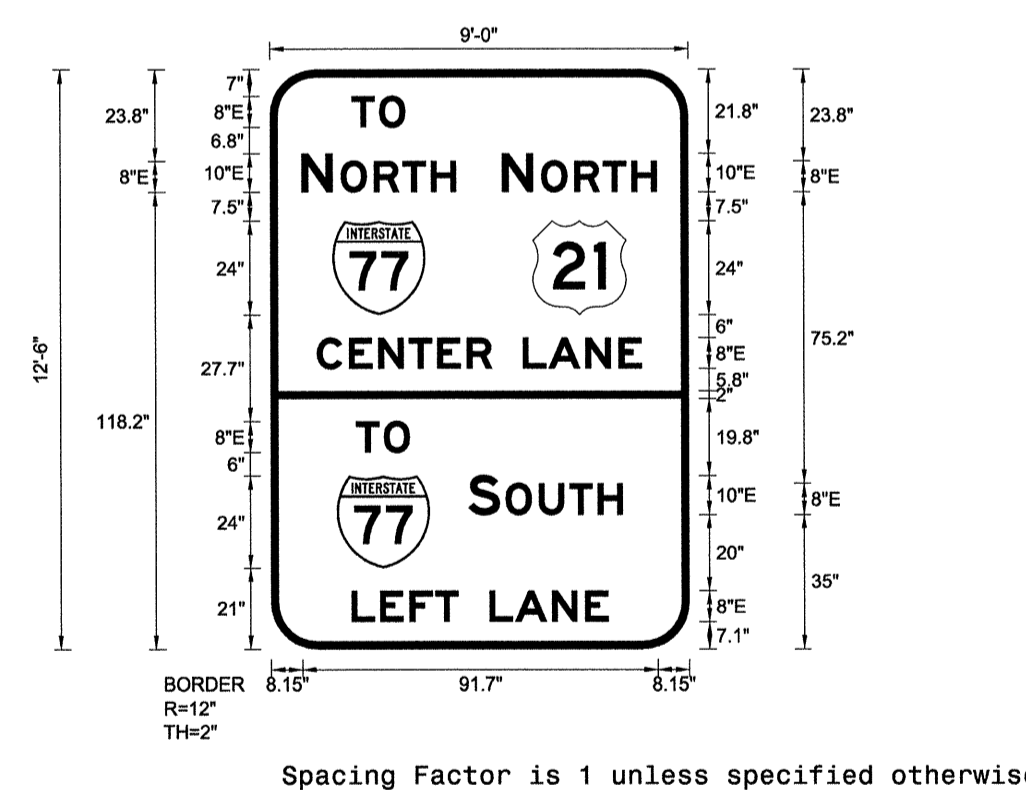

- USE NOTES
- Legend and border (except those that are colored black) shall be direct applied Grade C sheeting.
 - Background shall be Grade C reflective sheeting.
 - Shields; A, B, and C type arrows shall be on 0.032" (0.8mm) aluminum and demountable.

LETTER POSITIONS

Letter spacings are to start of next letter

	T	O									Series/Size Text Length	
21.2	7.1	6.7	73								E 2000	
	N	O	R	T	H						E 2000	
8.1	8.1	2.1	8.6	7.4	7.4	6.5	59.9				40	
	N	O	R	T	H						E 2000	
59.9	8.1	2.1	8.6	7.4	7.4	6.5	8.1				40	
	C	E	N	T	E	R	L	A	N	E	E 2000	
12	8.3	7.6	7.8	7.4	7.6	6.5	8	6.6	9.5	8.6	6	12
	T	O									E 2000	
22.2	7.1	6.7	72								13.8	
	S	O	U	T	H						E 2000	
51.1	8.1	1.5	8.6	7.8	7.4	6.5	17.1				39.8	
	L	E	F	T	L	A	N	E			E 2000	
20.8	7.4	7.6	6.6	6	8	6.6	9.5	8.6	6	20.8	66.3	

TYPE 'A' SIGNS

APPROVED: *Betsy L. Watson*

DATE: 4/22/13

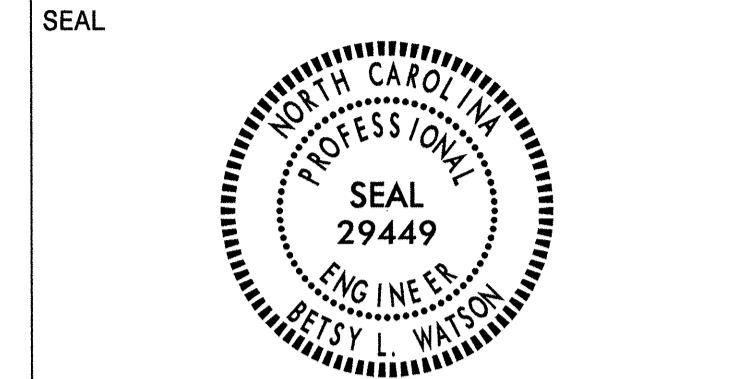

Stantec
Stantec Consulting Services Inc.
801 Jones Franklin Road
Suite 300
Raleigh, NC 27606
Tel. (919) 851-8866
Fax. (919) 851-7024
www.stantec.com
License No. F-0672

SIGN NUMBER: 301
TYPE: D
QUANTITY: 1
SIGN WIDTH: 96"
HEIGHT: 36"
TOTAL AREA: 24.0 Sq.Ft.
BORDER TYPE: FLUSH
RADI: 3"
WIDTH: 1"
RECESS: 0"
NO. Z BARS:
LENGTH:

BACKG COLOR: Green
COPY COLOR: White

SYMBOL	X	Y	WID	HT
AR_Type D	16	23	8	12
AR_Type D	78.5	5	8	12

MAT'L: 0.125" (3.2MM) ALUMINUM

DESIGN BY: RRH CHECKED BY: BLW DATE: Dec 06, 2012
PROJECT ID: I-4733 DIV: 10

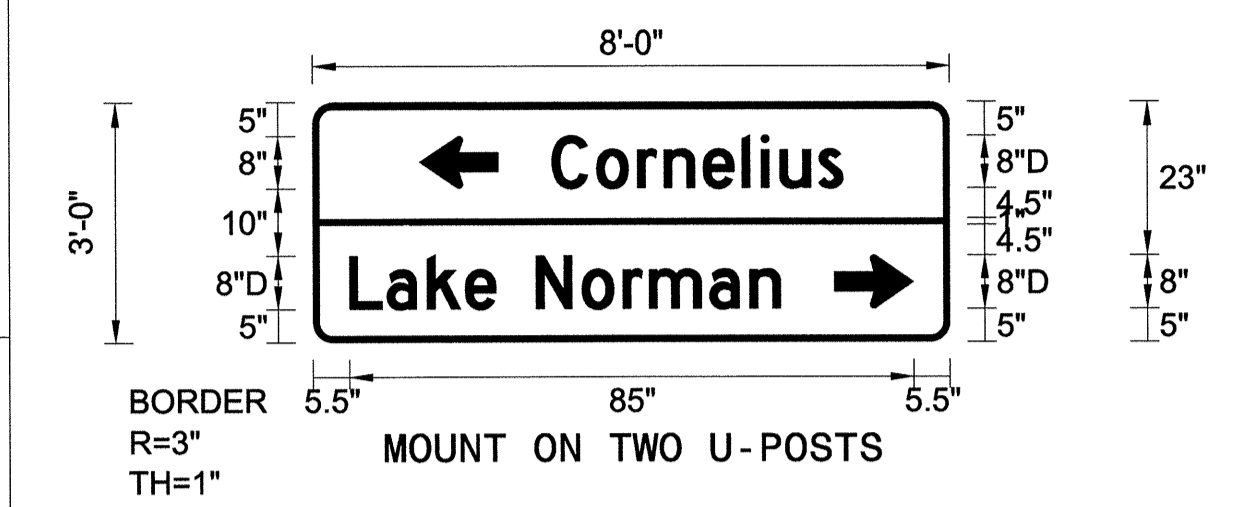

USE NOTES
1. Legend and border (except those that are colored black) shall be direct applied Grade C sheeting.
2. Background shall be Grade C reflective sheeting.

Spacing Factor is 1 unless specified otherwise

LETTER POSITIONS

Letter spacings are to start of next letter												Series/Size Text Length	
C	o	r	n	e	l	i	u	s				D 2000	
36	6.7	6.2	4	5.9	5.8	2.9	2.8	5.8	3.8	16		43.9	
L	a	k	e	N	o	r	m	a	n			D 2000	
5.5	5.6	6.1	5.8	4.7	6	6.9	6.2	4	9	6.1	4.7	25.5	65

SIGN NUMBER: 302
TYPE: D
QUANTITY: 1
SIGN WIDTH: 78"
HEIGHT: 24"
TOTAL AREA: 13.0 Sq.Ft.
BORDER TYPE: FLUSH
RADI: 3"
WIDTH: 1"
RECESS: 0"
NO. Z BARS:
LENGTH:

BACKG COLOR: Green
COPY COLOR: White

SYMBOL	X	Y	WID	HT
AR_Type D	9	6	8	12

MAT'L: 0.125" (3.2MM) ALUMINUM

DESIGN BY: RRH CHECKED BY: BLW DATE: Dec 06, 2012
PROJECT ID: I-4733 DIV: 10

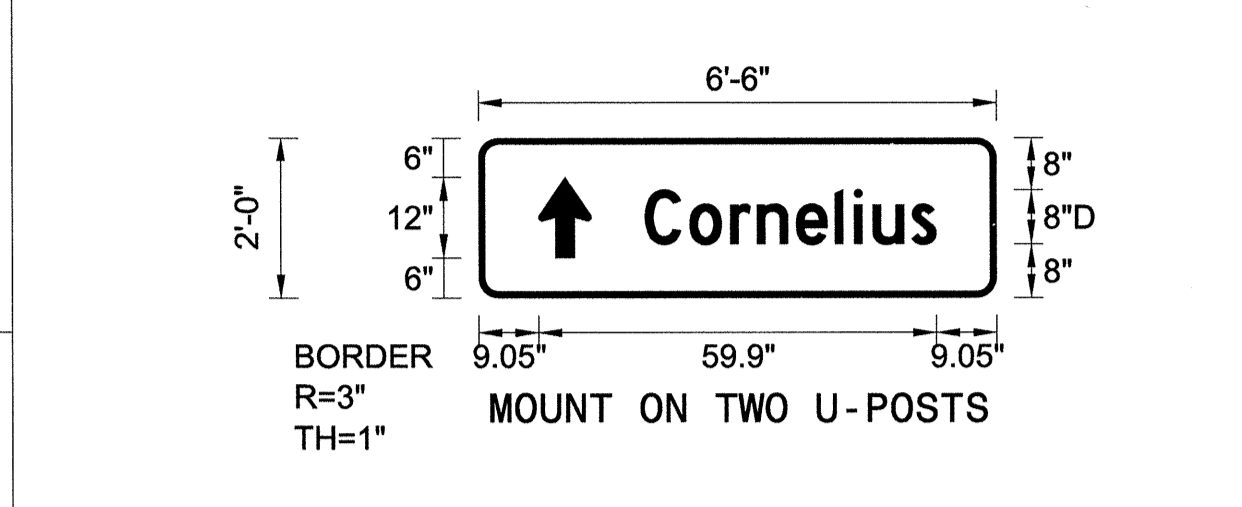

USE NOTES
1. Legend and border (except those that are colored black) shall be direct applied Grade C sheeting.
2. Background shall be Grade C reflective sheeting.

Spacing Factor is 1 unless specified otherwise

LETTER POSITIONS

Letter spacings are to start of next letter											Series/Size Text Length
C	o	r	n	e	l	i	u	s			D 2000
25	6.7	6.2	4	5.9	5.8	2.9	2.8	5.8	3.8	9	43.9

SIGN NUMBER: 303
TYPE: D
QUANTITY: 1
SIGN WIDTH: 96"
HEIGHT: 36"
TOTAL AREA: 24.0 Sq.Ft.
BORDER TYPE: FLUSH
RADI: 3"
WIDTH: 1"
RECESS: 0"
NO. Z BARS:
LENGTH:

BACKG COLOR: Green
COPY COLOR: White

SYMBOL	X	Y	WID	HT
AR_Type D	5.5	23	8	12
AR_Type D	68	5	8	12

MAT'L: 0.125" (3.2MM) ALUMINUM

DESIGN BY: RRH CHECKED BY: BLW DATE: Dec 06, 2012
PROJECT ID: I-4733 DIV: 10

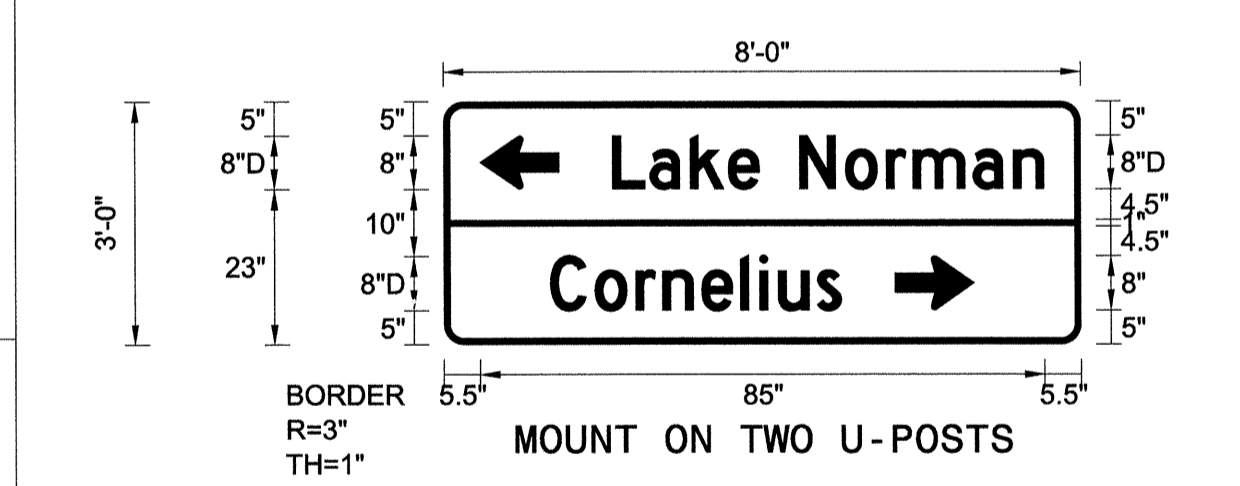

USE NOTES
1. Legend and border (except those that are colored black) shall be direct applied Grade C sheeting.
2. Background shall be Grade C reflective sheeting.

Spacing Factor is 1 unless specified otherwise

LETTER POSITIONS

Letter spacings are to start of next letter												Series/Size Text Length	
L	a	k	e	N	o	r	m	a	n			D 2000	
25.5	5.6	6.1	5.8	4.7	6	6.9	6.2	4	9	6.1	4.7	5.5	65
C	o	r	n	e	l	i	u	s				D 2000	
16	6.7	6.2	4	5.9	5.8	2.9	2.8	5.8	3.8	36			43.9

4/2/2013 U:\Frontier\Signing\CADD\Signing_Layout_Plans\I-4733_Sign_sheets\I-5.dgn

APPROVED: *Betsy L. Watson*

DATE: 4/22/13

SEAL



Stantec
 Stantec Consulting Services Inc.
 801 Jones Franklin Road
 Suite 300
 Raleigh, NC 27606
 Tel. (919) 851-8866
 Fax. (919) 851-7024
 www.stantec.com
 License No. F-0672



BEGIN STATE SIGNING PROJECT
 I-4733 -L- STA. 11+50

SEE NOTE 7
 JCT JCT *600' +/- WEST
 OF STA 10+00

- PROJECT NOTES**
- 1 SIGN ERECTION, RELOCATE SIGN TYPE A
 - 2 SIGN ERECTION, RELOCATE SIGN TYPE B
 - 3 SIGN ERECTION, RELOCATE SIGN TYPE D
 - 4 SIGN ERECTION, RELOCATE SIGN TYPE F
 - 5 DISPOSAL OF SIGN SYSTEM ON SPAN WIRE
 - 6 DISPOSAL OF SUPPORT, STEEL BEAM
 - 7 DISPOSAL OF SIGN SYSTEM, U-CHANNEL
 - 8 DISPOSAL OF SUPPORT, U-CHANNEL
 - 9 DISPOSAL OF SIGN, D, E, OR F

EXISTING SIGNING
 CATAWBA AVE
 STA. 11+50 TO 23+05

APPROVED: *Betsy L. Watson*

DATE: 4/22/13

SEAL

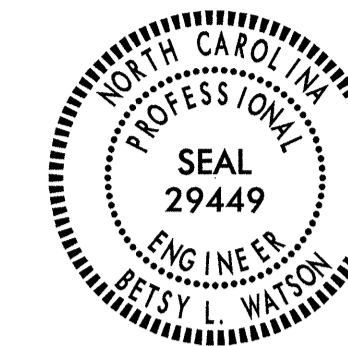

Stantec Consulting Services Inc.
801 Jones Franklin Road
Suite 300
Raleigh, NC 27606
Tel. (919) 851-6866
Fax. (919) 851-7024
www.stantec.com
License No. F-0672

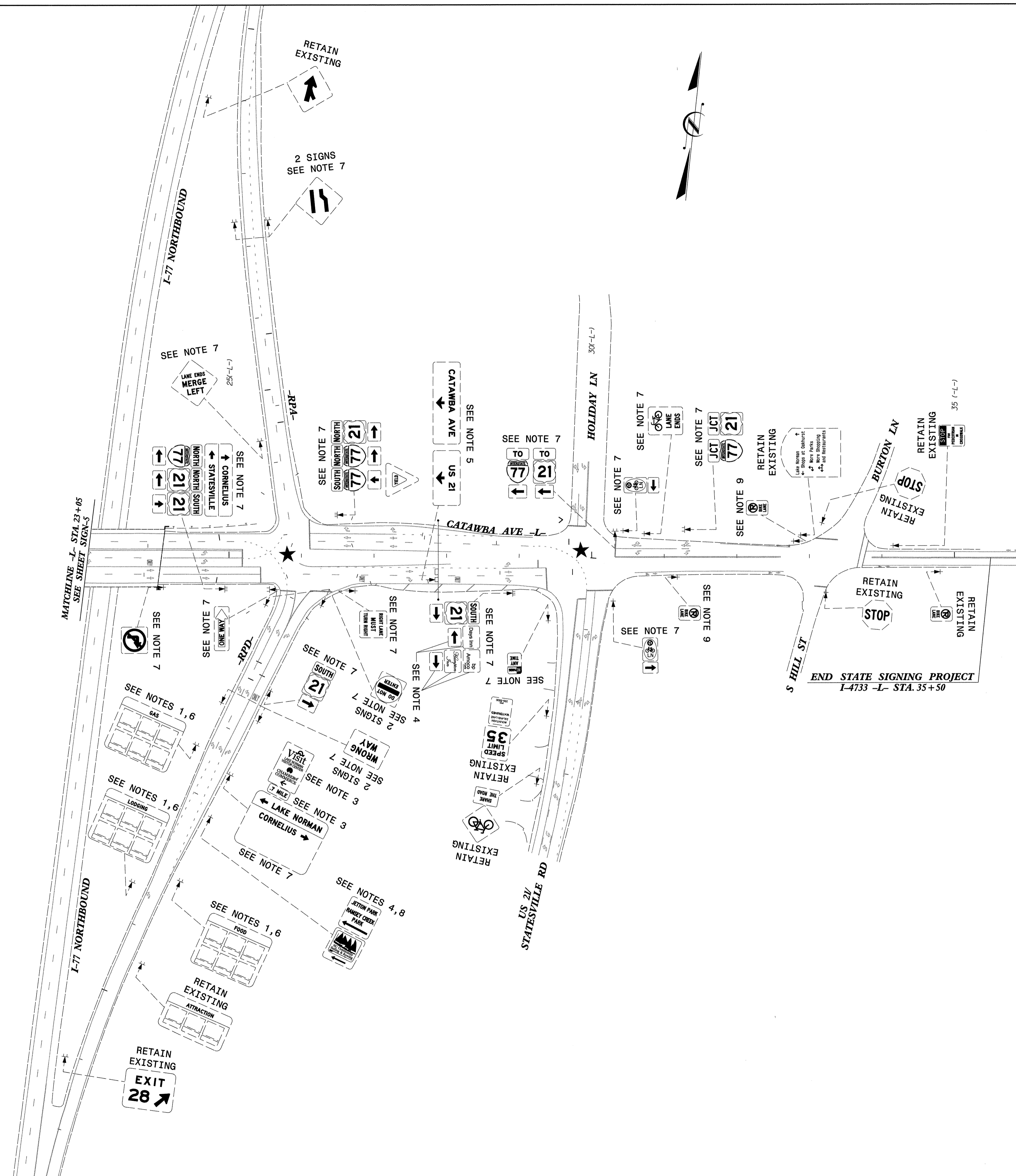

PROJECT NOTES

- 1 SIGN ERECTION, RELOCATE SIGN TYPE A
- 2 SIGN ERECTION, RELOCATE SIGN TYPE B
- 3 SIGN ERECTION, RELOCATE SIGN TYPE D
- 4 SIGN ERECTION, RELOCATE SIGN TYPE F
- 5 DISPOSAL OF SIGN SYSTEM ON SPAN WIRE
- 6 DISPOSAL OF SUPPORT, STEEL BEAM
- 7 DISPOSAL OF SIGN SYSTEM, U-CHANNEL
- 8 DISPOSAL OF SUPPORT, U-CHANNEL
- 9 DISPOSAL OF SIGN, D, E, OR F

EXISTING SIGNING
CATAWBA AVE
STA. 23+05 TO 36+00

APPROVED: *Patsy L. Watson*

DATE: 4/22/13

SEAL



Stantec
Stantec Consulting Services Inc.
801 Jones Franklin Road
Suite 300
Raleigh, NC 27606
Tel. (919) 851-6866
Fax. (919) 851-7024
www.stantec.com
License No. F-0672

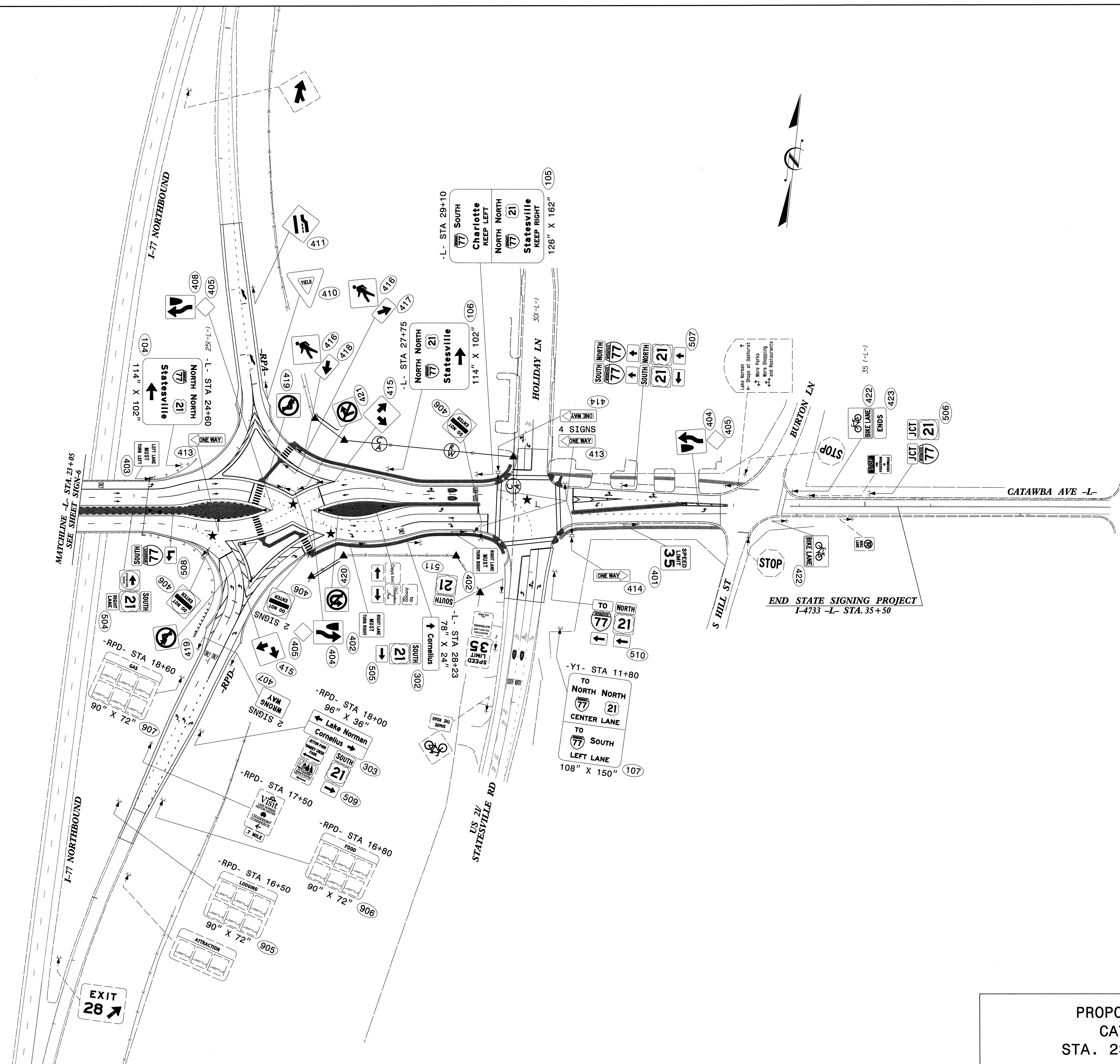

PROPOSED SIGNING
CATAWBA AVE
STA. 23+05 TO 38+75