

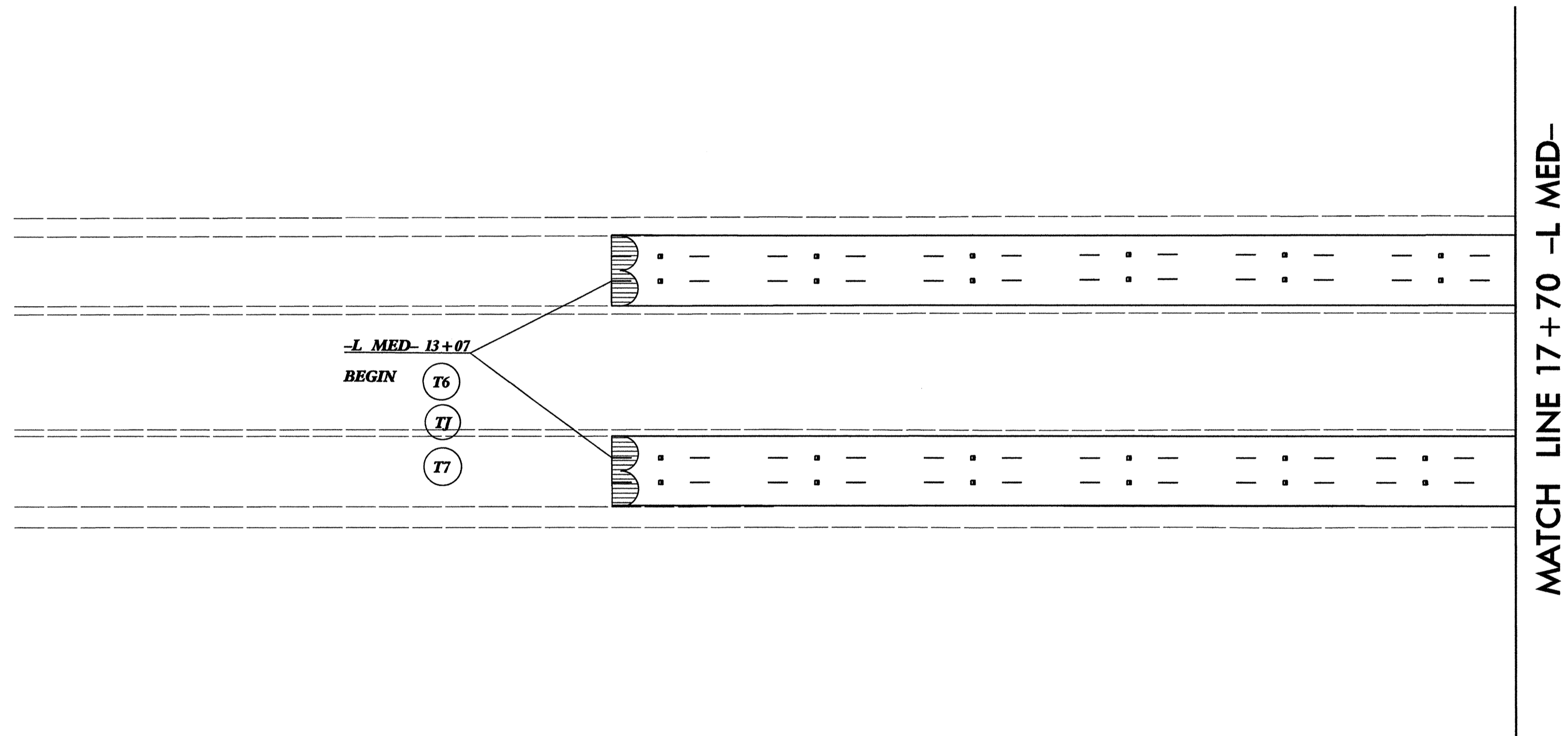



PROJECT REFERENCE NO.	SHEET NO.
I-5314	PMP 2
RW SHEET NO.	
DIVISION DESIGN & CONSTRUCT ENGINEER	
	
<i>Greg S. Davis</i> 4-1-13	



REVISIONS

PROJECT REFERENCE NO.	SHEET NO.
I-5314	PMP 3
RW SHEET NO.	
DIVISION DESIGN & CONSTRUCT ENGINEER  <i>Greg S. Davis</i> 4-1-13	

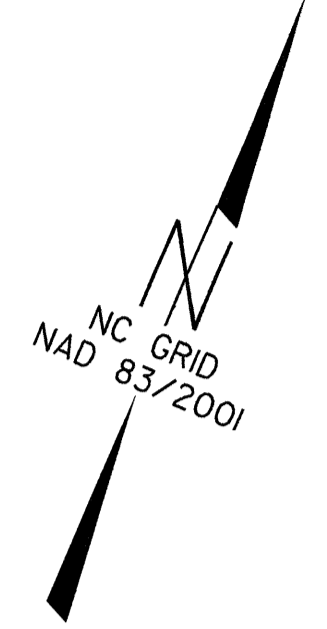

MATCH LINE 17+70 -L MED-

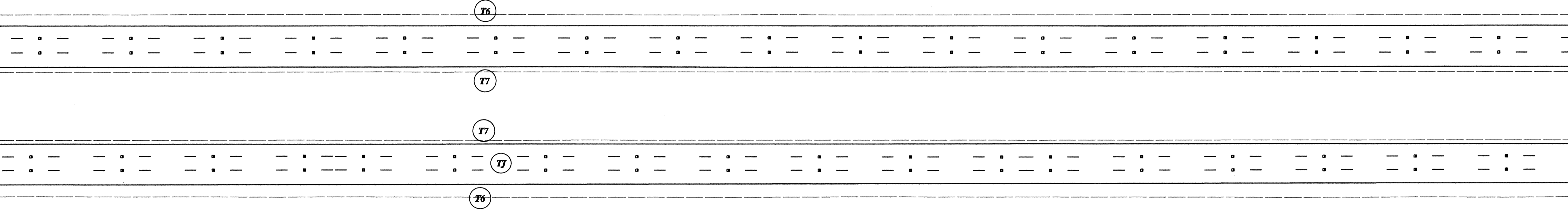

MATCH LINE 31+58 -L MED-

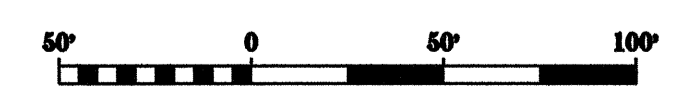

REVISIONS

8/17/99

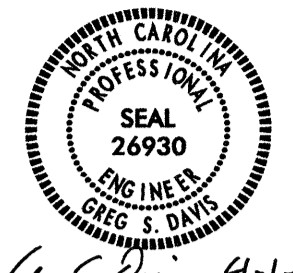
PROJECT REFERENCE NO. I-5314	SHEET NO. PMP 4
RW SHEET NO.	
DIVISION DESIGN & CONSTRUCT ENGINEER	
	
Greg S. Davis 4-1-13	

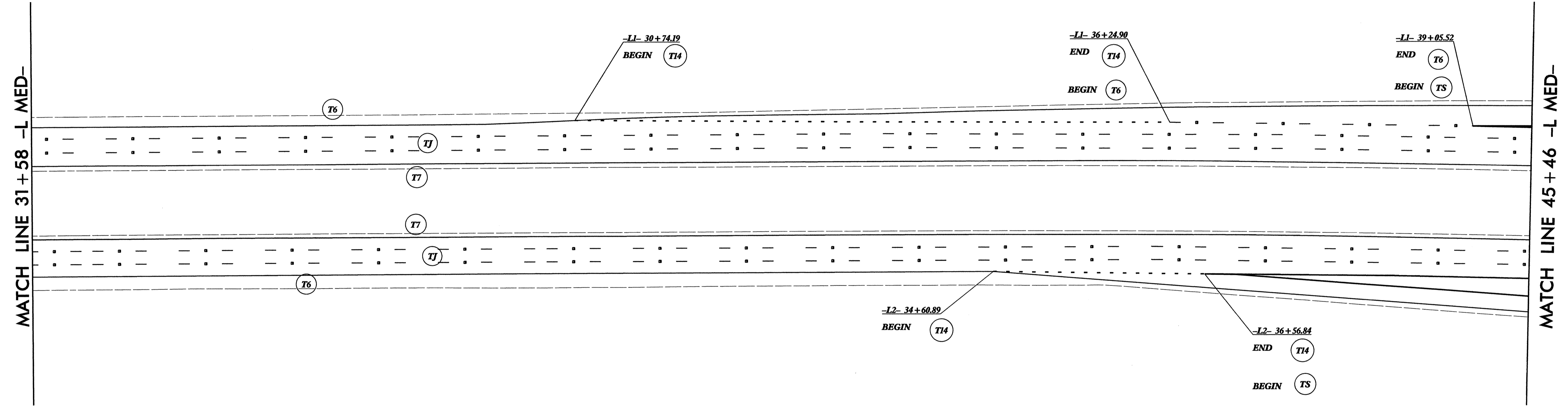
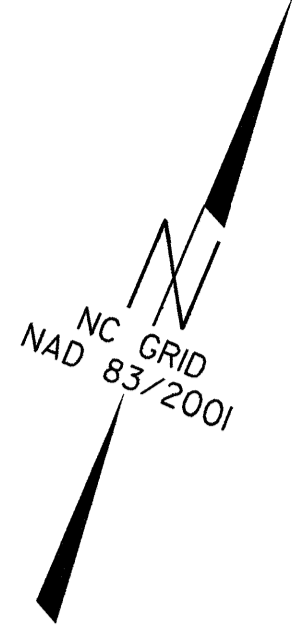

REVISIONS

Q:\APR-2013 Iltz3  
 C:\drive8\_pr\_0\projects\rd\yengde\p\I-5314\psh\pmp\I-5314\_PSH\_PMP 4.dgn  
 11/08/2013 2:46:03

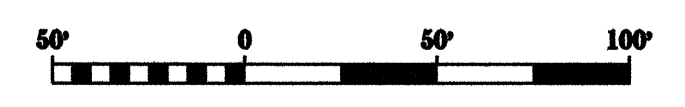

PROJECT REFERENCE NO. I-5314	SHEET NO. PMP 5
RW SHEET NO.	
DIVISION DESIGN & CONSTRUCT ENGINEER  <i>Greg S. Davis</i> 4-1-13	

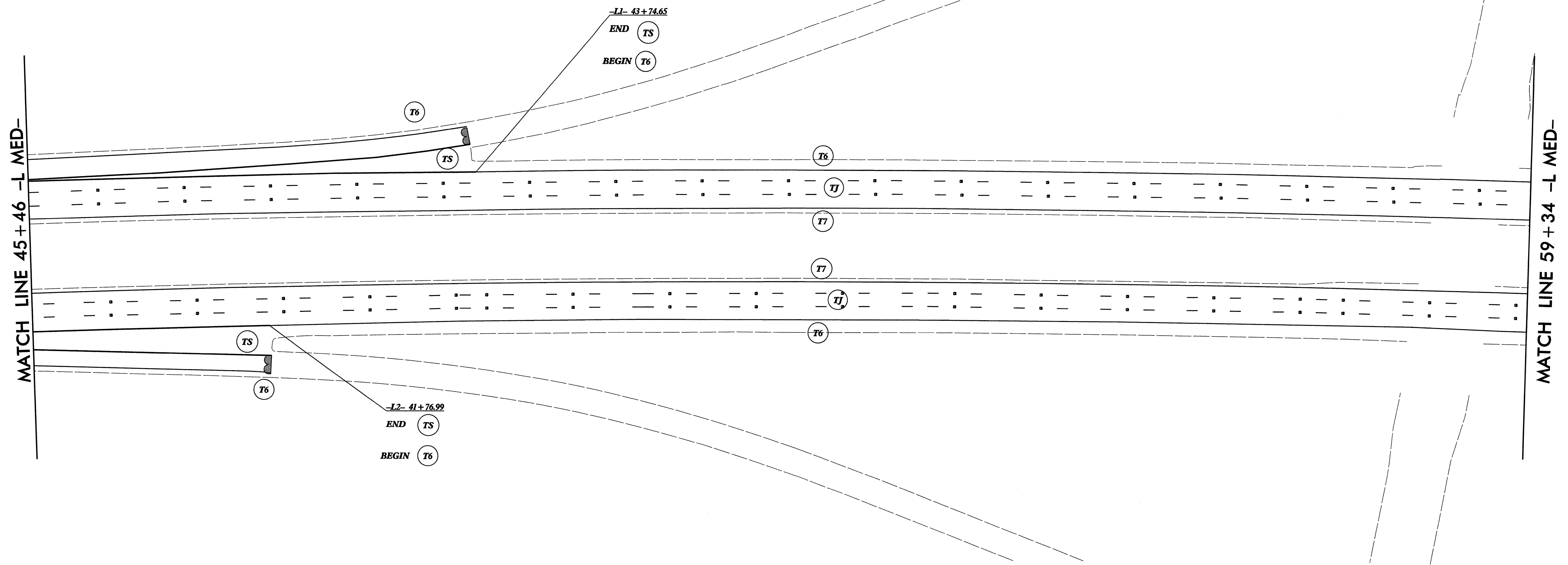
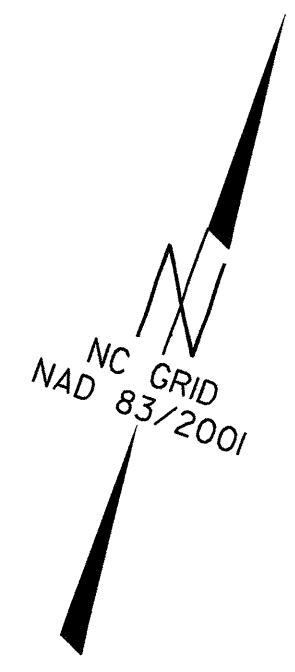

REVISIONS

01-APR-2013 11:23  
 C:\drive\pr\21681001\5314\psd\iph\I-5314\psh\pmp\I-5314\_PSH\_PMP\_5.dgn  
 01-APR-2013 11:23

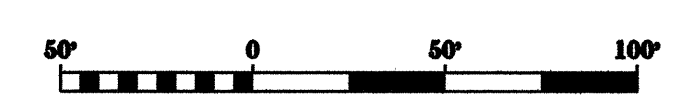

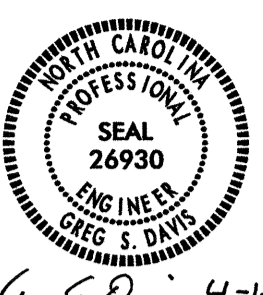
PROJECT REFERENCE NO.	SHEET NO.
I-5314	PMP 6
RW SHEET NO.	
DIVISION DESIGN & CONSTRUCT ENGINEER	
	
GSD on 4-143	

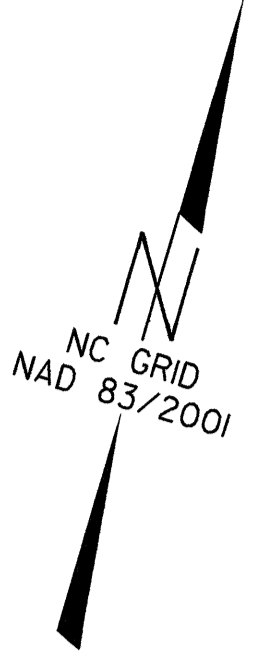

MATCH LINE 59 + 34 - L MED-

MATCH LINE 73 + 22 - L MED-

-L1- 62 + 77.32  
 BEGIN (TS)  
 END (T6)

-L1- 66 + 06.68  
 END (TS)  
 BEGIN (T14)

-L2- 63 + 10.47  
 BEGIN (TS)  
 END (T6)

(T6)

(T7)

(T7)

(T7)

(T7)

(T6)

(TS)

(T6)

(TS)

(T6)

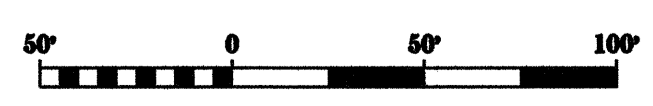

REVISIONS

01-APR-2013 litz3  
 4:46:56 PM  
 C:\Users\lit33\Documents\Projects\I-5314\I-5314\_PSH.PMP\_6.dgn



8/17/99

01-APR-2013 11:23  
C:\p06\cpr\proj\5314\psd\5314\_PSH\_PMP\_7.dgn

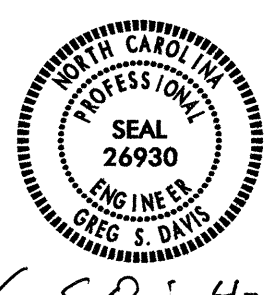
PROJECT REFERENCE NO. I-5314	SHEET NO. PMP 7
RW SHEET NO.	
DIVISION DESIGN & CONSTRUCT ENGINEER	
	
GSD 4-1-13	

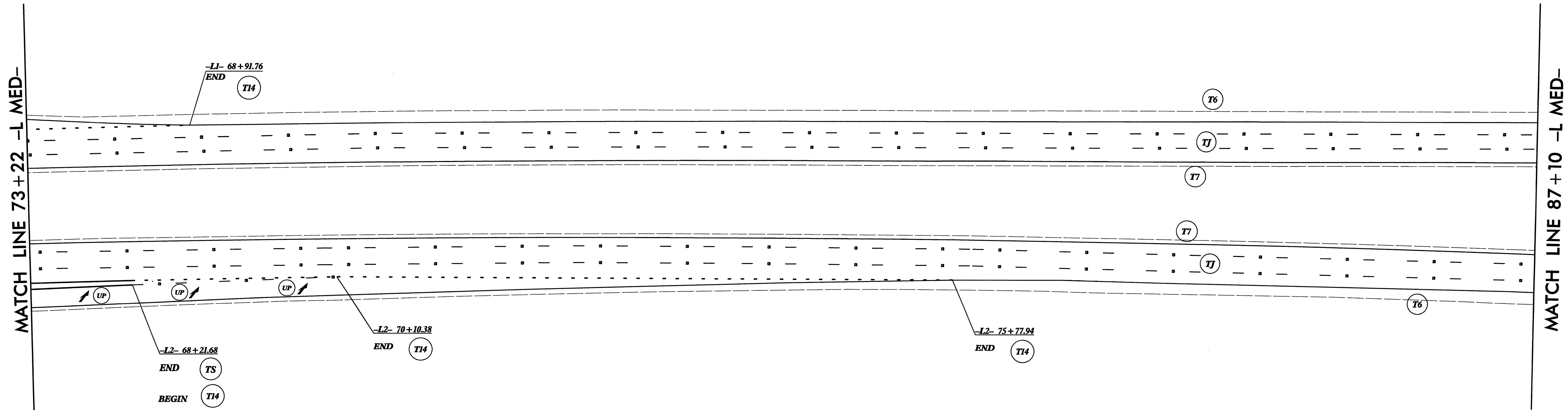
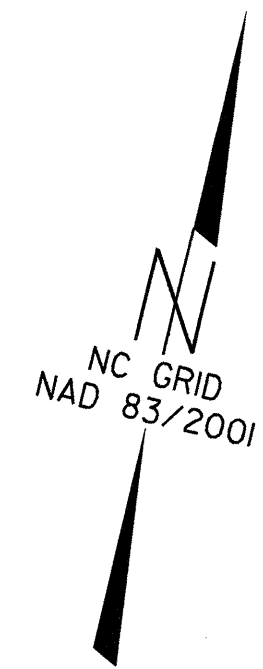

REVISIONS

8/17/99

REVISIONS

C:\APR\_2013\_11z3  
2-pr  
0108740246463  
I:\5314\psh\pmp\5314\_PSH\_PMP\_8.dgn

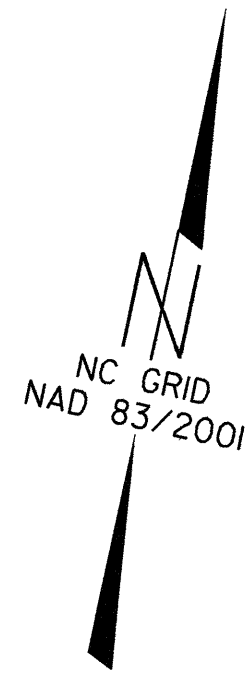

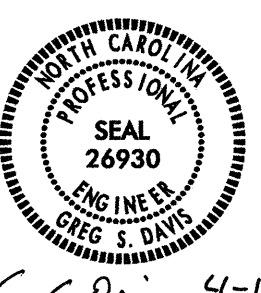
PROJECT REFERENCE NO.	SHEET NO.
I-5314	PMP 8
RW SHEET NO.	
DIVISION DESIGN & CONSTRUCT ENGINEER  <i>G.S. Davis</i> 4-1-13	

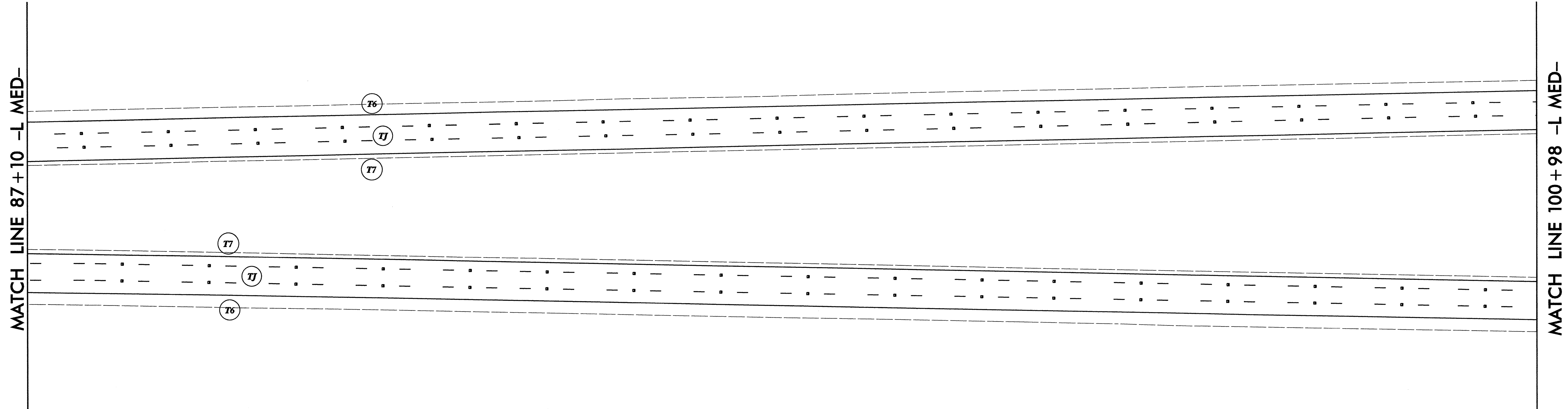



8/17/99

PROJECT REFERENCE NO.	SHEET NO.
I-5314	PMP 9
RW SHEET NO.	
DIVISION DESIGN & CONSTRUCT ENGINEER	
 Greg S. Davis 4-1-13	

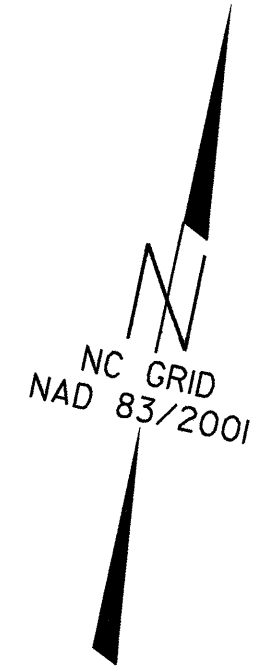

REVISIONS

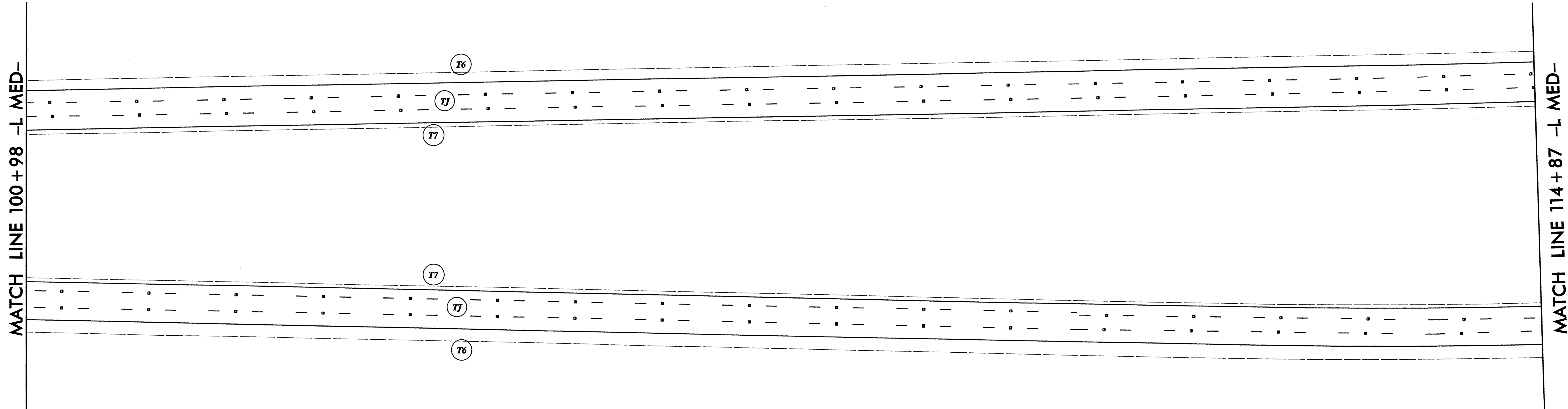

01-APR-2013 11:23  
 C:\d\8-pr-9\pmp\pmp\1-5314\psh\pmp\1-5314\_PSH\_PMP\_9.dgn  
 10/16/13

8/17/99

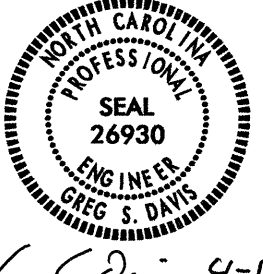
PROJECT REFERENCE NO.	SHEET NO.
I-5314	PMP 10
RW SHEET NO.	
DIVISION DESIGN & CONSTRUCT ENGINEER  <i>Greg S. Davis</i> 4-1-13	



REVISIONS

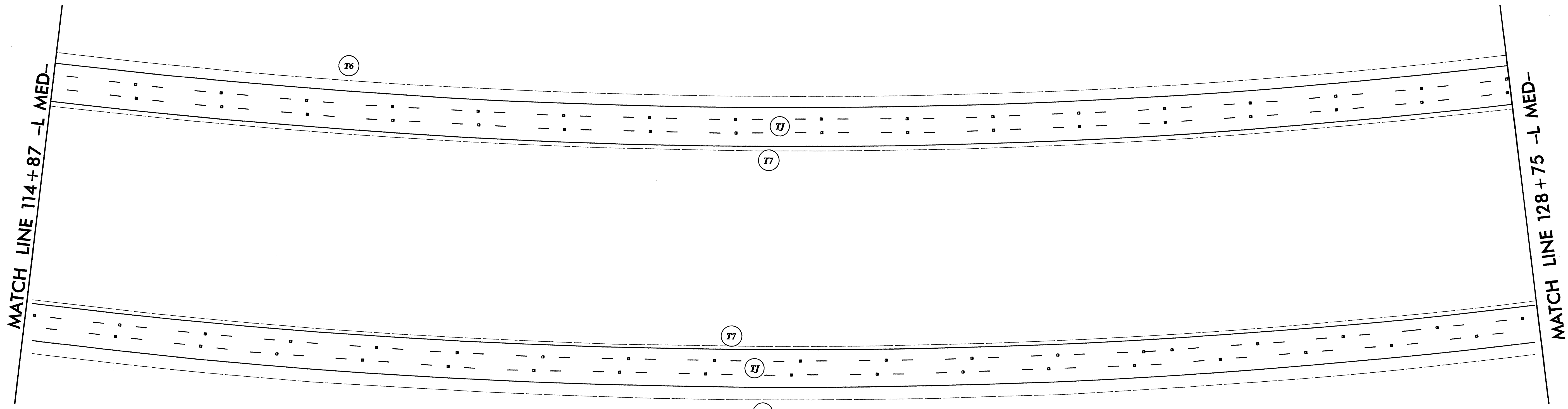

01-APR-2013 11:23  
 C:\Users\paul\Documents\Projects\I-5314\psh\pmp\I-5314\_PSH.PMP 10.dgn



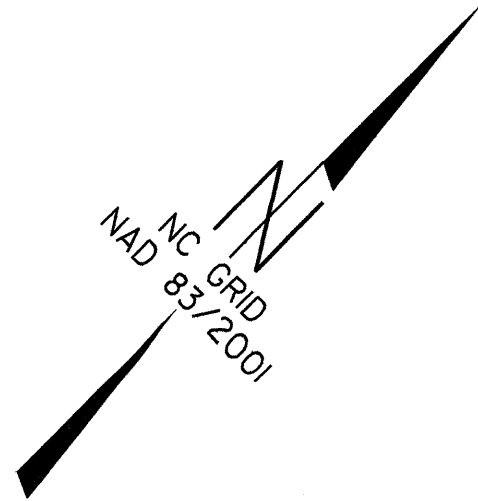

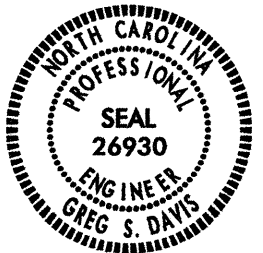
PROJECT REFERENCE NO. I-5314	SHEET NO. PMP 12
RW SHEET NO.	
DIVISION DESIGN & CONSTRUCT ENGINEER	
 G.S.D. 4-1-13	

REVISIONS

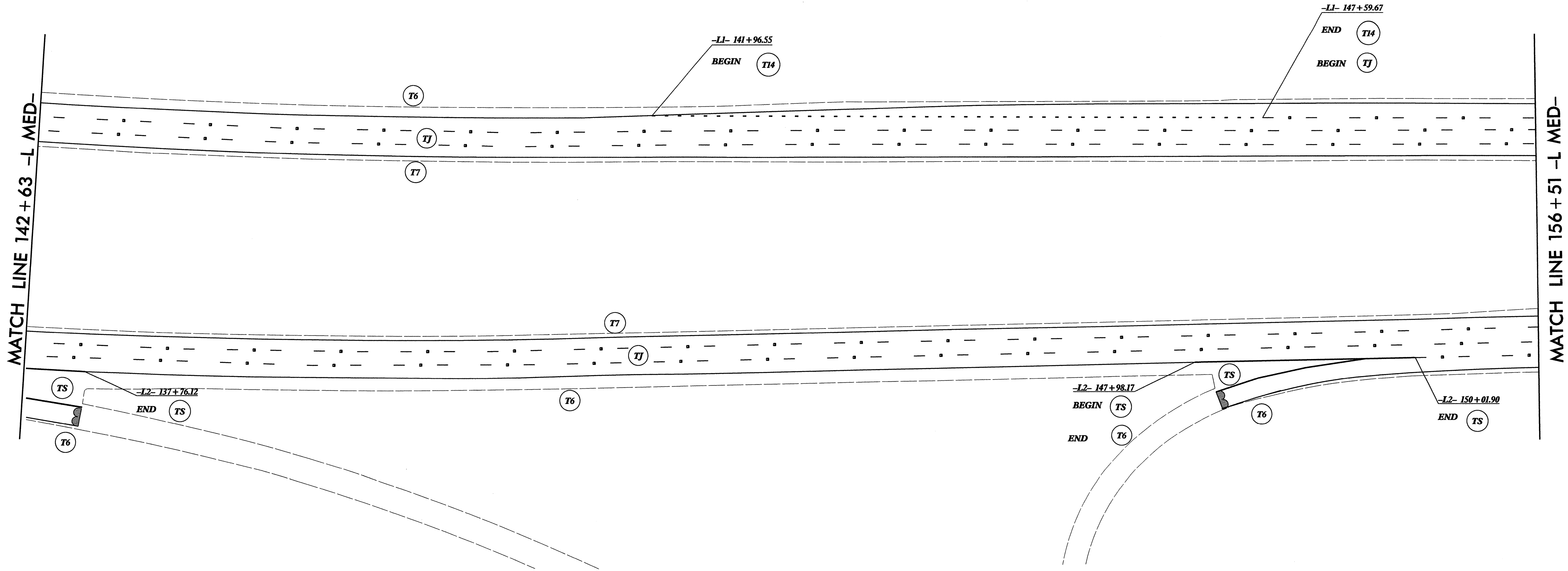



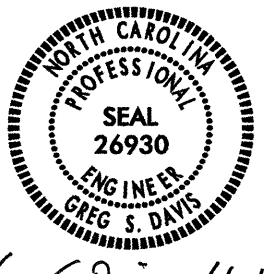

8/17/99

01-APR-2013 11:23  
C:\GIS\p1\91180\APR\5314\psh\pmp\1-5314\_PSH\_PMP\_14.dgn

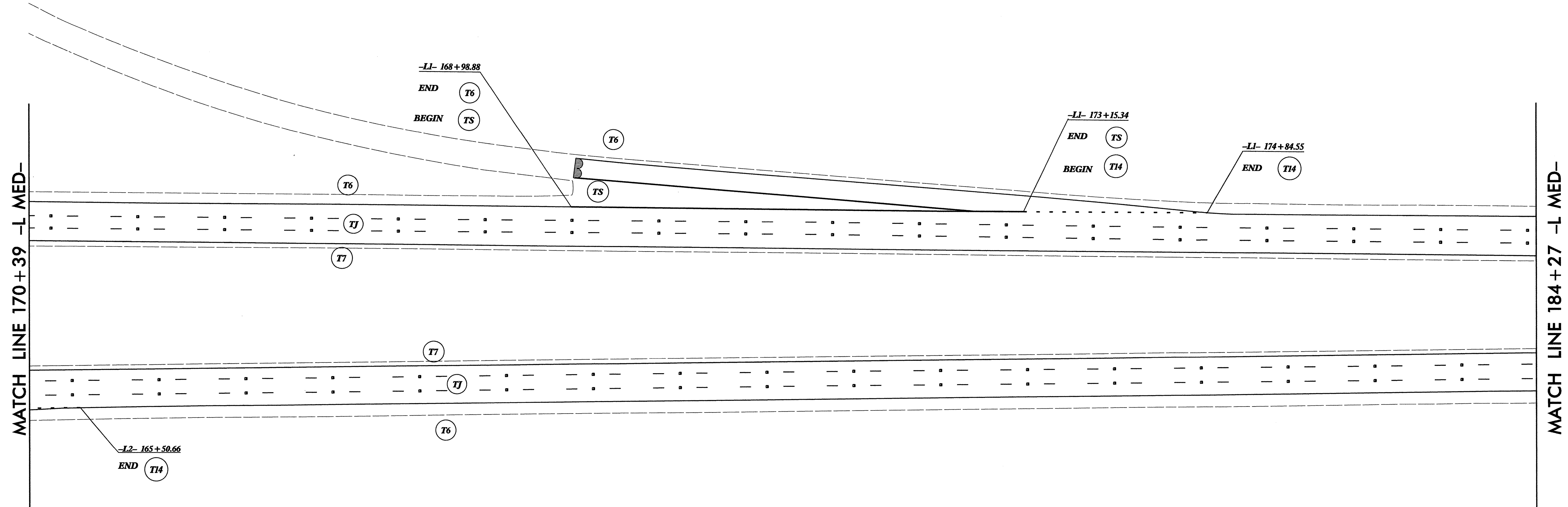
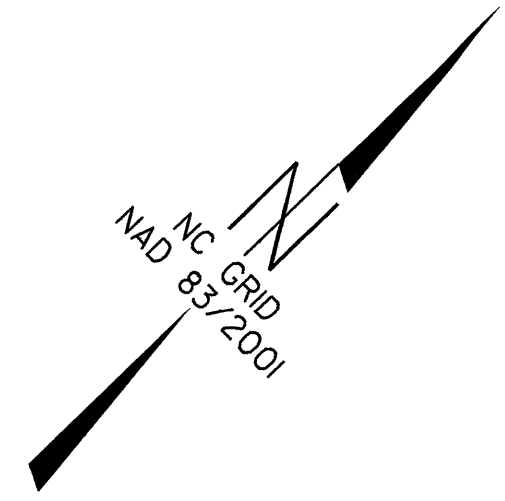
PROJECT REFERENCE NO. I-5314	SHEET NO. PMP 14
RW SHEET NO.	
DIVISION DESIGN & CONSTRUCT ENGINEER  <i>Greg S. Davis</i> 4-1-13	



REVISIONS

PROJECT REFERENCE NO.	SHEET NO.
I-5314	PMP 15
RW SHEET NO.	
DIVISION DESIGN & CONSTRUCT ENGINEER	
	
Greg S. Davis 4-1-13	

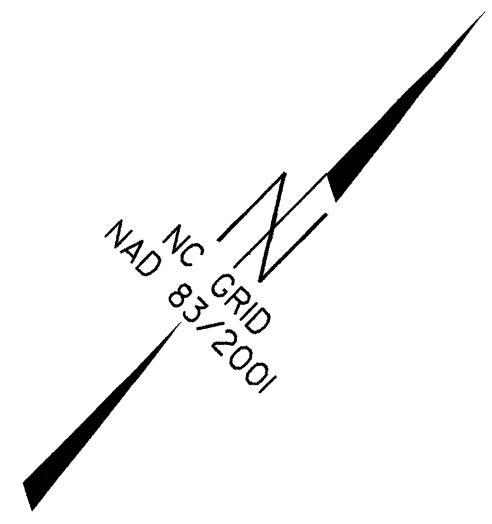

REVISIONS

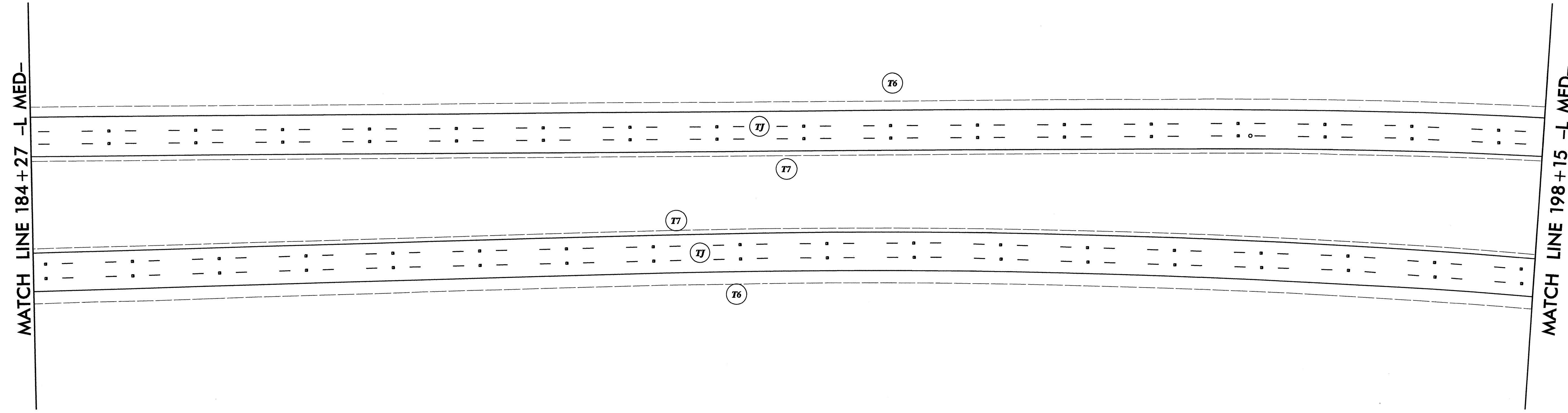

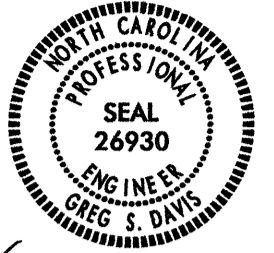

PROJECT REFERENCE NO.	SHEET NO.
I-5314	PMP 16
RW SHEET NO.	
DIVISION DESIGN & CONSTRUCT ENGINEER  <i>Greg S. Davis</i> 4-1-13	

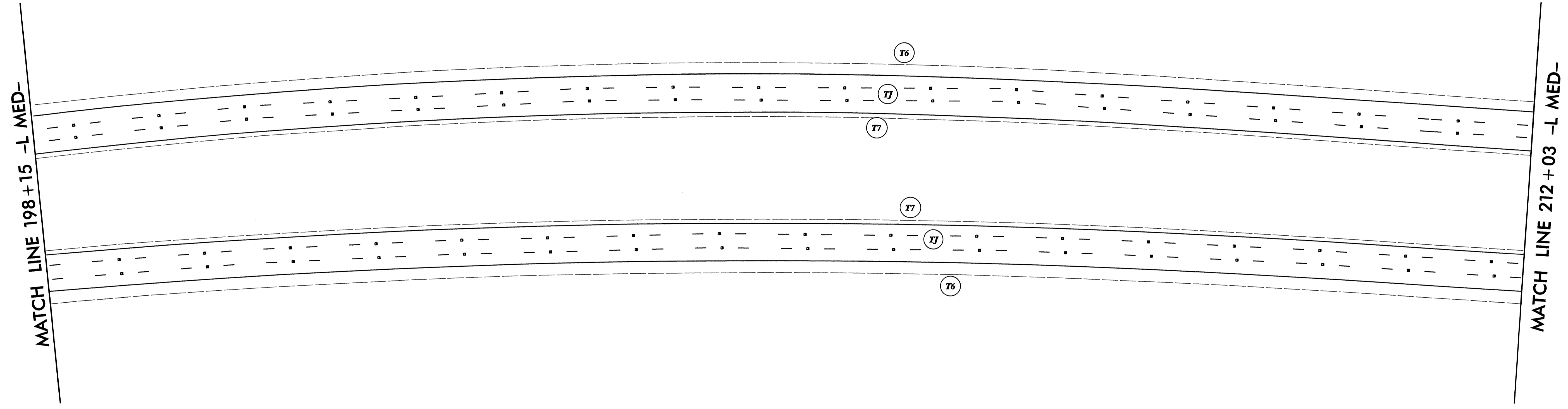
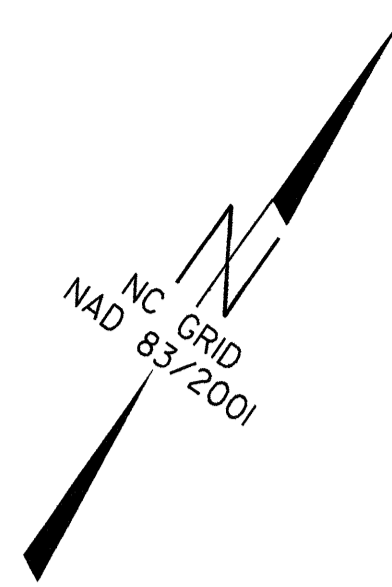

REVISIONS

Q1-AFR-2013 11z23  
 C:\drive2-pr-21-01-01\psh\5314\psh\5314\psh\5314\_PSH\_PMP\_16.dgn  
 4/1/13 10:21:13 AM





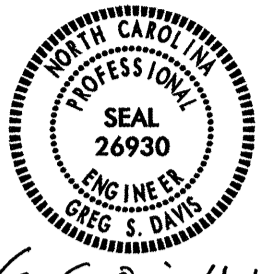

8/17/99

PROJECT REFERENCE NO.	SHEET NO.
I-5314	PMP 20
RW SHEET NO.	
DIVISION DESIGN & CONSTRUCT ENGINEER  <i>Greg S. Davis</i> 4-1-13	

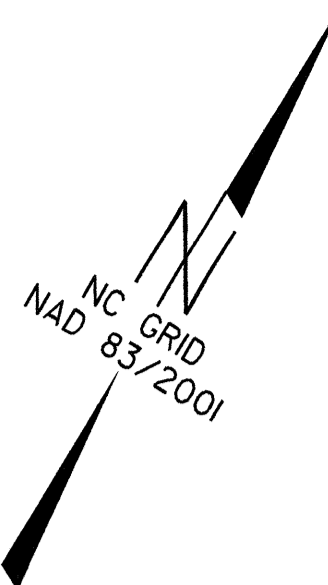

REVISIONS

MATCH LINE 253+67 -L MED-

MATCH LINE 267+55 -L MED-

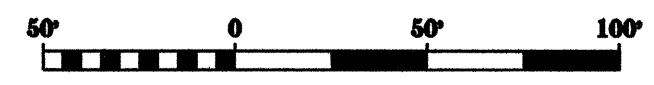
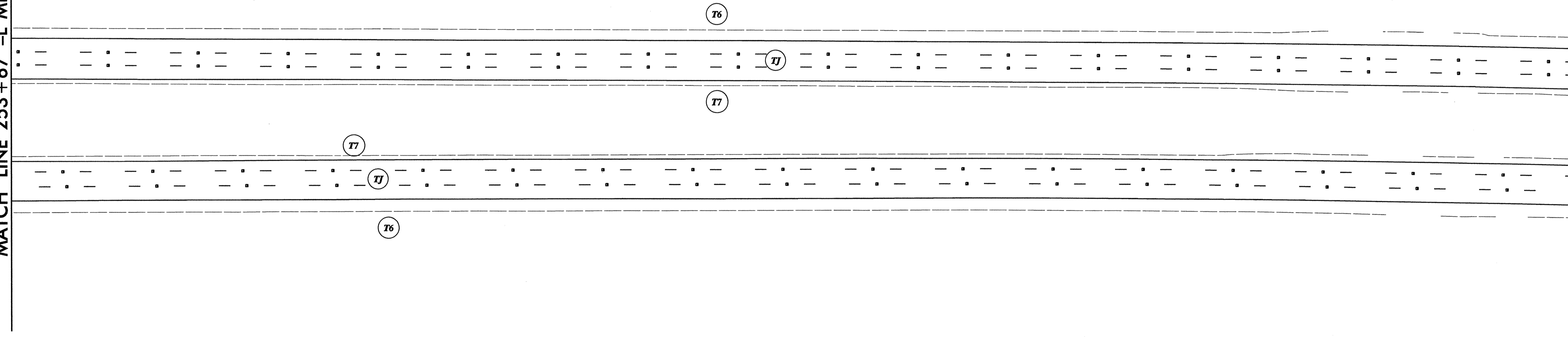

01-APP-2013-1123  
 C:\apps\prg\cadd\psh\pmp\5314\psh\pmp\5314\_PSH\_PMP\_20.dgn  
 05/21/13 10:46:53

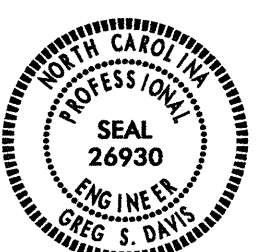
PROJECT REFERENCE NO.	SHEET NO.
I-5314	PMP 21
RW SHEET NO.	
DIVISION DESIGN & CONSTRUCT ENGINEER	
	
Greg S. Davis 4-1-13	

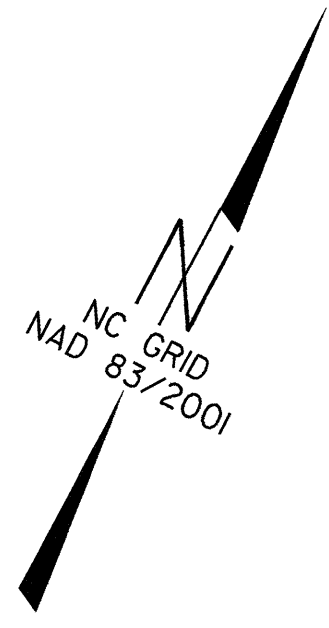

REVISIONS

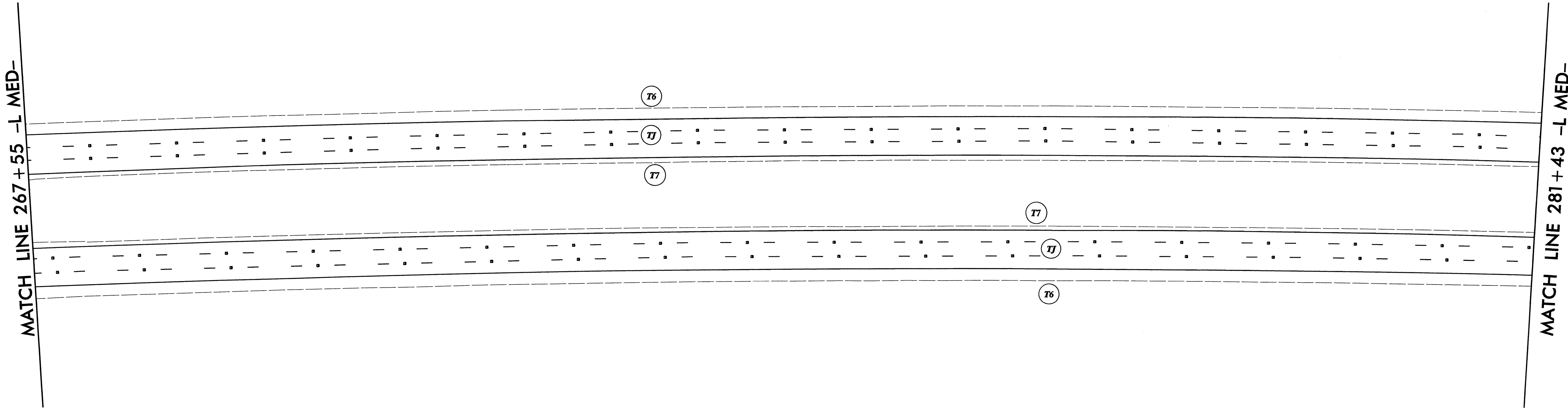

Q:\AFR\2013\1623  
 C:\Users\pratt\OneDrive\Documents\1623\1623.dwg  
 I:\5314\psh\pmp\I-5314\_PSH\_PMP\_21.dgn



8/17/99

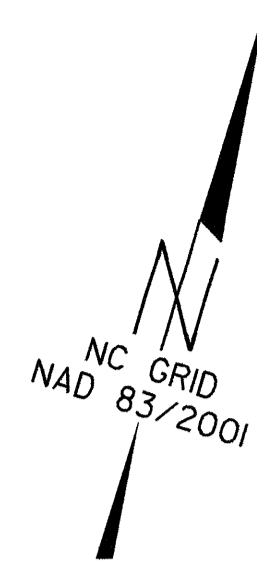

PROJECT REFERENCE NO.	SHEET NO.
I-5314	PMP 22
RW SHEET NO.	
DIVISION DESIGN & CONSTRUCT ENGINEER	
	
Greg S. Davis 4-1-13	

REVISIONS

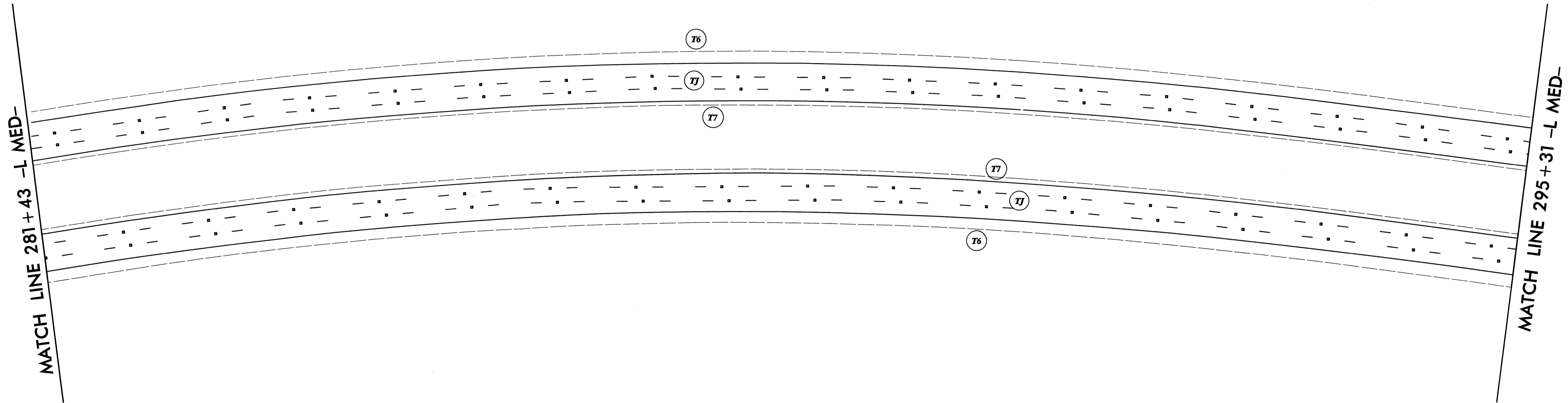

C:\APP\2013\1123\GIS\GIS\prj\01-5314\psd\pmp\5314\_PSH\_PMP\_22.dgn  
 01-APP-2013-1123-01-5314-PSH-PMP-22.dgn  
 01-APP-2013-1123-01-5314-PSH-PMP-22.dgn



8/17/99

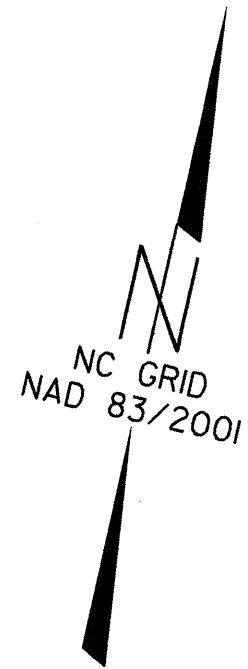

PROJECT REFERENCE NO. I-5314	SHEET NO. PMP 23
RW SHEET NO.	
DIVISION DESIGN & CONSTRUCT ENGINEER	
 Greg S. Davis 4-1-13	

REVISIONS

MATCH LINE 295+31 -L MED-

MATCH LINE 309+19 -L MED-

-L1- 294+09.96  
 END (TJ) (T6) (T7)  
 BEGIN (VJ) (V6) (V7)

-L1- 296+14.38  
 END (VJ) (V6) (V7)  
 BEGIN (TJ) (T6) (T7)

-L2- 294+97.11  
 END (TJ) (T6) (T7)  
 BEGIN (VJ) (V6) (V7)

-L1- 294+25.47  
 END (VJ) (V6) (V7)  
 BEGIN (TJ) (T6) (T7)

-L1- 296+29.00  
 END (VJ) (V6) (V7)  
 BEGIN (TJ) (T6) (T7)

-L2- 297+06.08  
 END (VJ) (V6) (V7)  
 BEGIN (TJ) (T6) (T7)

-L2- 295+12.42  
 END (TJ) (T6) (T7)  
 BEGIN (VJ) (V6) (V7)

-L2- 297+20.62  
 END (VJ) (V6) (V7)  
 BEGIN (TJ) (T6) (T7)



01-APR-2013 11:23  
 C:\Users\pmp\Documents\Projects\I-5314\psh\pmp\I-5314\_PSH\_PMP\_23.dgn





