

STATE OF NORTH CAROLINA  
NCDOT RAIL DIVISION

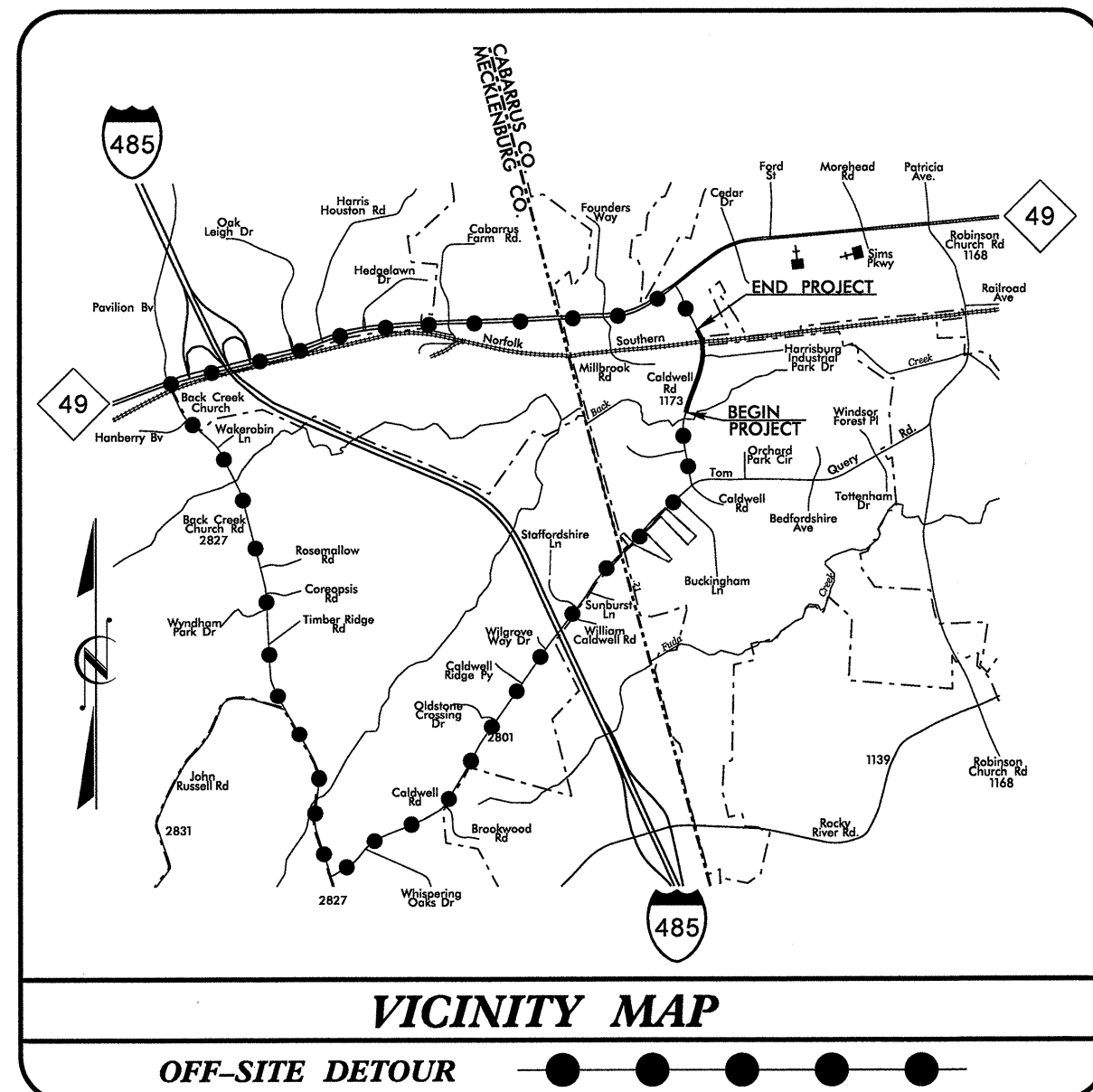

STATE	STATE PROJECT REFERENCE NO.	SHEET NO.	TOTAL SHEETS
N.C.	P-5208F	EC1	
STATE PROJ. NO.	F.A. PROJ. NO.	DESCRIPTION	
50000.1.STR22TIB		PE	

TIP PROJECT: P-5208F



LOCATION: PROPOSED CALDWELL ROAD (SR 1173) GRADE SEPARATION OVER THE NSNCRR RAILROAD IN HARRISBURG

# EROSION CONTROL PLANS

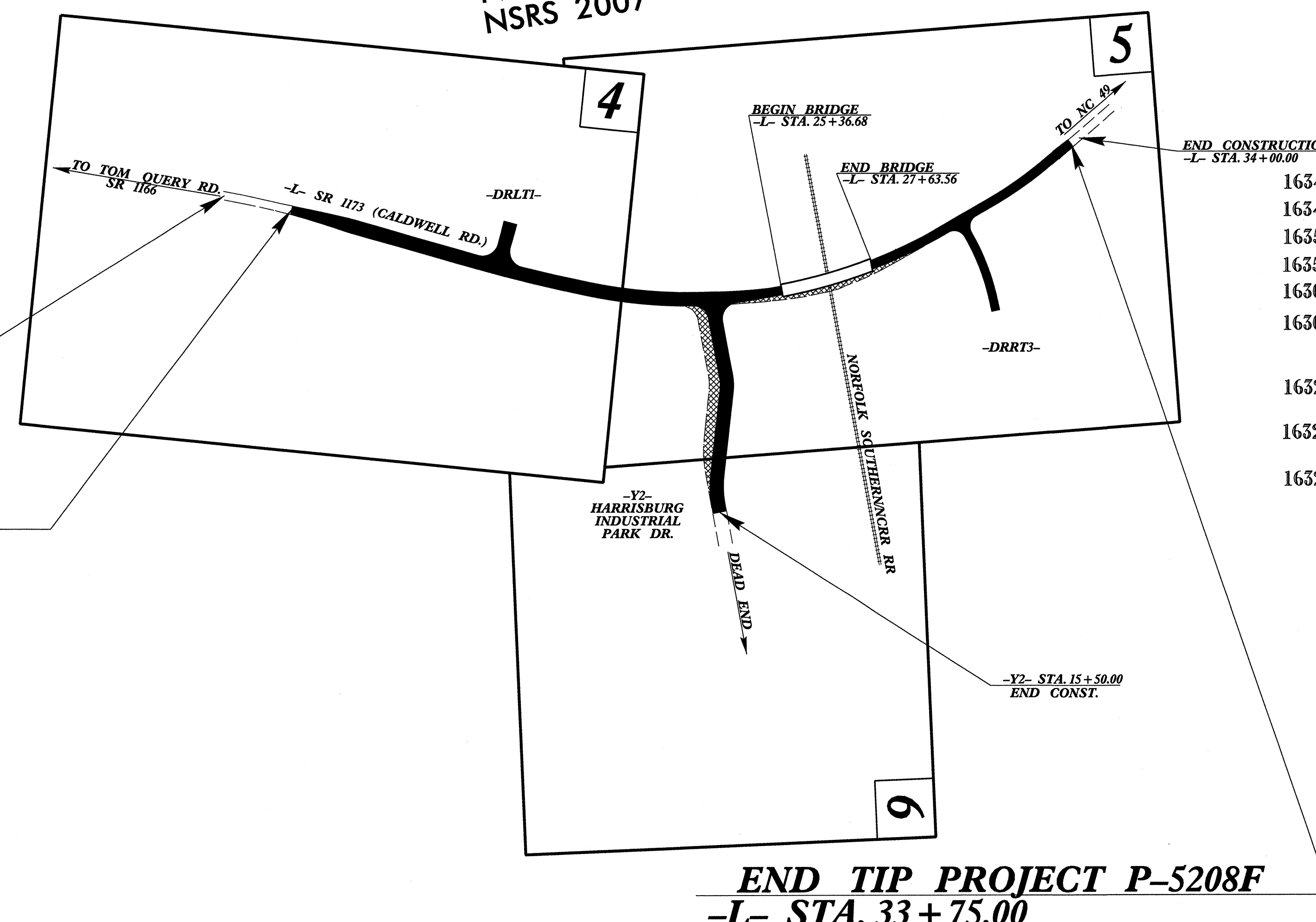
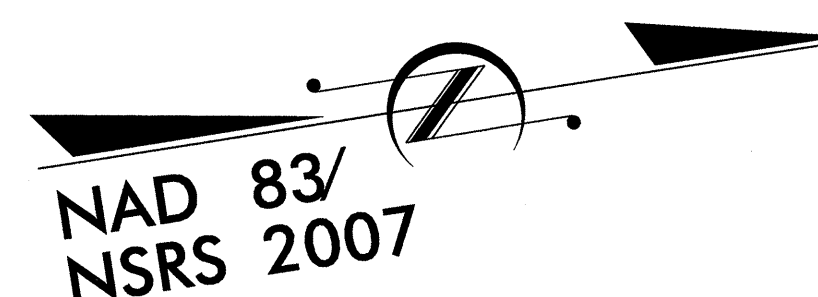

**BEGIN TIP PROJECT P-5208F**  
-L- STA. 12 + 50.00

**END TIP PROJECT P-5208F**  
-L- STA. 33 + 75.00

THESE EROSION AND SEDIMENT CONTROL PLANS COMPLY WITH THE REGULATIONS SET FORTH BY THE NCG-010000 GENERAL CONSTRUCTION PERMIT EFFECTIVE AUGUST 3, 2011 ISSUED BY THE NORTH CAROLINA DEPARTMENT OF ENVIRONMENT AND NATURAL RESOURCES DIVISION OF WATER QUALITY.

### EROSION AND SEDIMENT CONTROL MEASURES

Std. #	Description	Symbol
1630.03	Temporary Silt Ditch	TSD
1630.05	Temporary Diversion	TD
1605.01	Temporary Silt Fence	
1606.01	Special Sediment Control Fence	▲▲▲
1622.01	Temporary Berms and Slope Drains	—
	Silt Basin Type B	▢
1633.01	Temporary Rock Silt Check Type-A	▣
	Temporary Rock Silt Check Type-A with Matting and Polyacrylamide (PAM)	▣
	Temporary Rock Silt Check Type-B	▣
	Wattle/Coir Fiber Wattle	—
	Wattle/Coir Fiber Wattle with Polyacrylamide (PAM)	—
1634.01	Temporary Rock Sediment Dam Type-A	▣
1634.02	Temporary Rock Sediment Dam Type-B	▣
1635.01	Rock Pipe Inlet Sediment Trap Type-A	▣
1635.02	Rock Pipe Inlet Sediment Trap Type-B	▣
1630.04	Stilling Basin	▣
1630.06	Special Stilling Basin	▣
	Rock Inlet Sediment Trap:	
1632.01	Type A	A
1632.02	Type B	B
1632.03	Type C	C
	Skimmer Basin	▣

THIS PROJECT CONTAINS EROSION CONTROL PLANS FOR CLEARING AND GRUBBING PHASE OF CONSTRUCTION.

LEVEL III-A EROSION CONTROL CERTIFICATION BY:  
**JAMES C. DAVIS, P.E.**  
CERTIFICATION NO.: 633

CONTRACT:

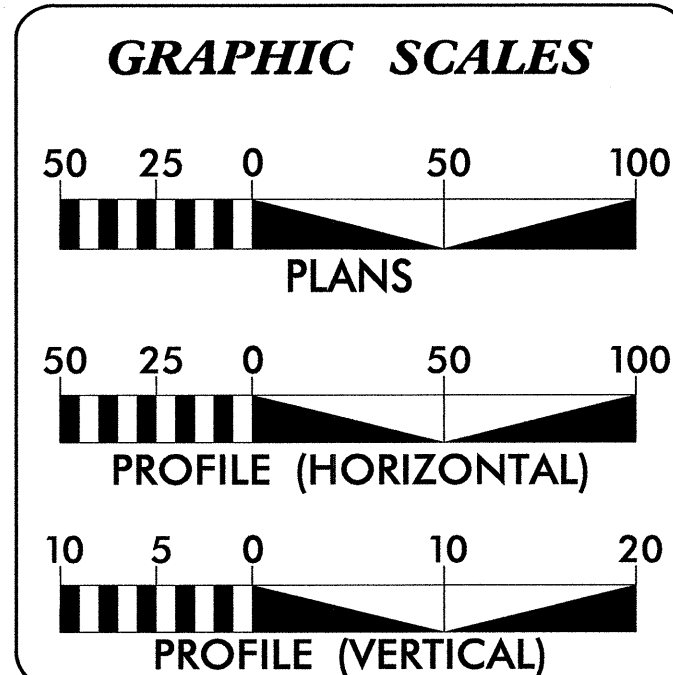

ROADSIDE ENVIRONMENTAL UNIT  
DIVISION OF HIGHWAYS  
STATE OF NORTH CAROLINA  
2012 STANDARD SPECIFICATIONS

#### Roadway Standard Drawings

The following roadway english standards as appear in "Roadway Standard Drawings"- Roadway Design Unit - N. C. Department of Transportation - Raleigh, N. C., dated January 2012 and the latest revision thereto are applicable to this project and by reference hereby are considered a part of these plans.

- |  |  |
|--|--|
| 1604.01 Railroad Erosion Control Detail  | 1632.01 Rock Inlet Sediment Trap Type A      |
| 1605.01 Temporary Silt Fence             | 1632.02 Rock Inlet Sediment Trap Type B      |
| 1606.01 Special Sediment Control Fence   | 1632.03 Rock Inlet Sediment Trap Type C      |
| 1607.01 Gravel Construction Entrance     | 1633.01 Temporary Rock Silt Check Type A     |
| 1622.01 Temporary Berms and Slope Drains | 1633.02 Temporary Rock Silt Check Type B     |
| 1630.01 Riser Basin                      | 1634.01 Temporary Rock Sediment Dam Type A   |
| 1630.02 Silt Basin Type B                | 1634.02 Temporary Rock Sediment Dam Type B   |
| 1630.03 Temporary Silt Ditch             | 1635.01 Rock Pipe Inlet Sediment Trap Type A |
| 1630.04 Stilling Basin                   | 1635.02 Rock Pipe Inlet Sediment Trap Type B |
| 1630.05 Temporary Diversion              | 1640.01 Coir Fiber Baffle                    |
| 1630.06 Special Stilling Basin           | 1645.01 Temporary Stream Crossing            |
| 1631.01 Matting Installation             |  |

**WETHERILL ENGINEERING**  
Prepared for the North Carolina Department of Transportation in the Office of:  
559 JONES FRANKLIN ROAD  
SUITE 164  
RALEIGH, N.C. 27606  
License No. F-0377  
Tel: 919 851 8077  
Fax: 919 851 8107

2012 STANDARD SPECIFICATIONS

RIGHT OF WAY DATE: **APRIL 16, 2012**

LETTING DATE: **MAY 21, 2013**

**EDWARD G. WETHERILL, PE**  
PROJECT ENGINEER

**BOB A. MAY, PE**  
PROJECT DESIGN ENGINEER

**HYDRAULICS ENGINEER**

**JAMES C. DAVIS, P.E.**  
1/21/13

**ROADWAY DESIGN ENGINEER**

SIGNATURE: \_\_\_\_\_

NC DEPARTMENT OF TRANSPORTATION  
**RAIL DIVISION**  
PLANNING AND DEVELOPMENT

CAPITAL TARD  
154 RAIL SERVICE CENTER  
RALEIGH, NC 27609-1544

PROJECT REFERENCE NO. P-5208F	SHEET NO. EC-2
RW SHEET NO.	
ROADWAY DESIGN ENGINEER	HYDRAULICS ENGINEER

# COIR FIBER WATTLE DETAIL

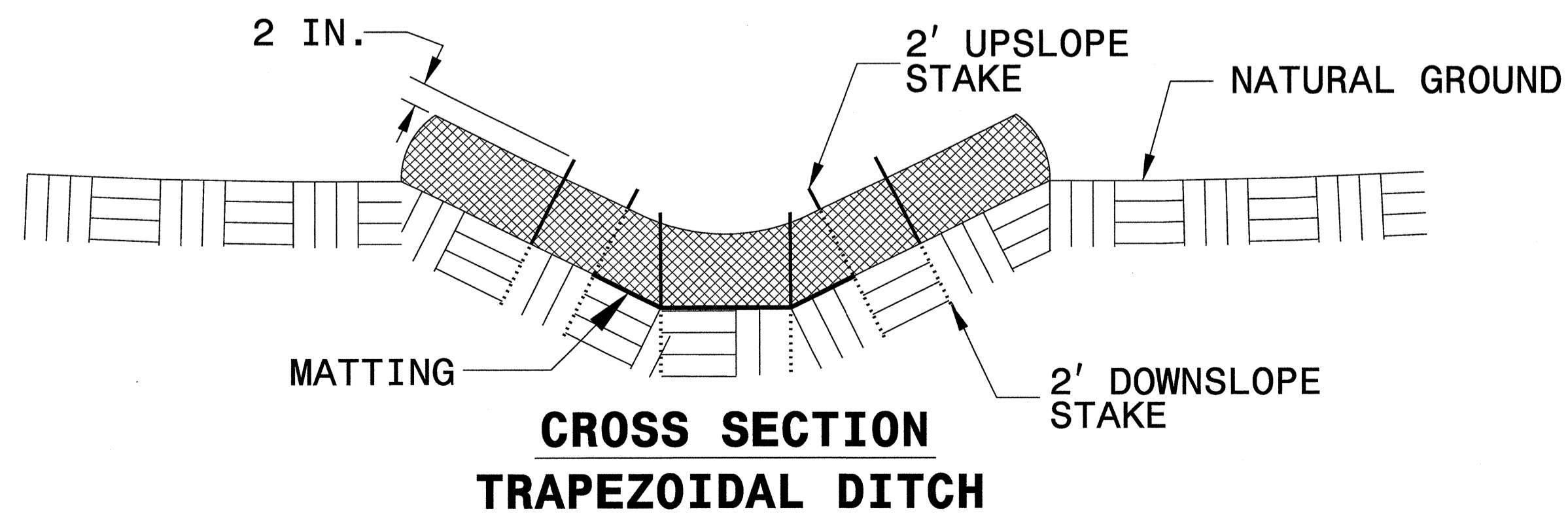
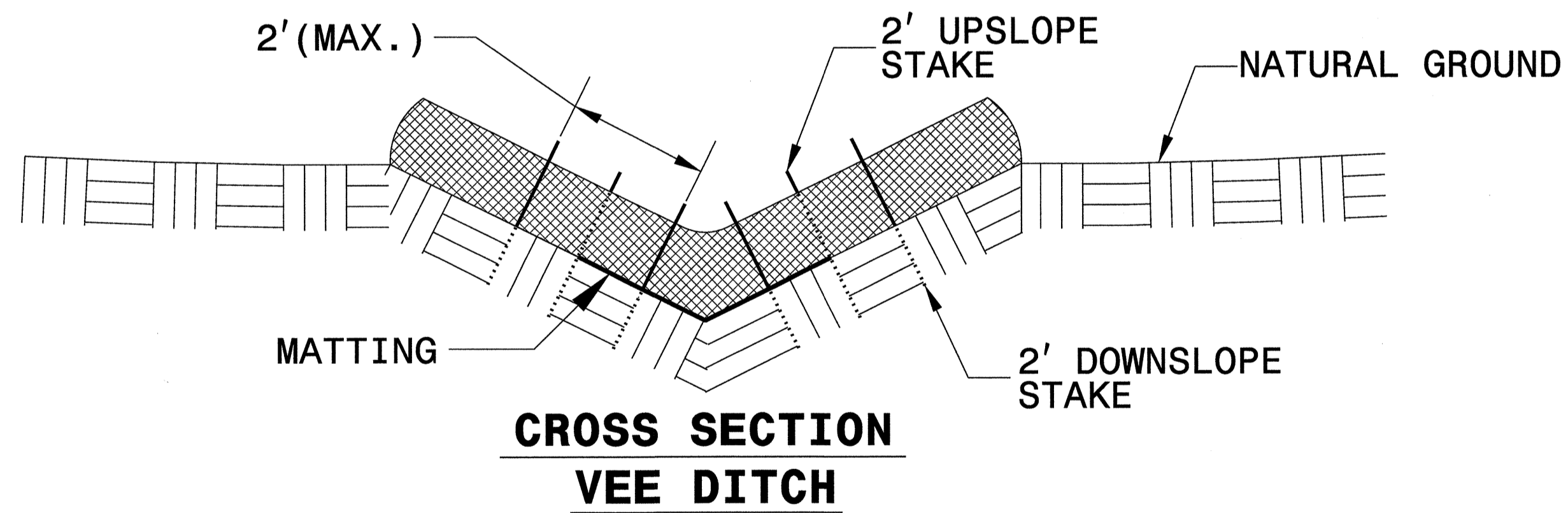
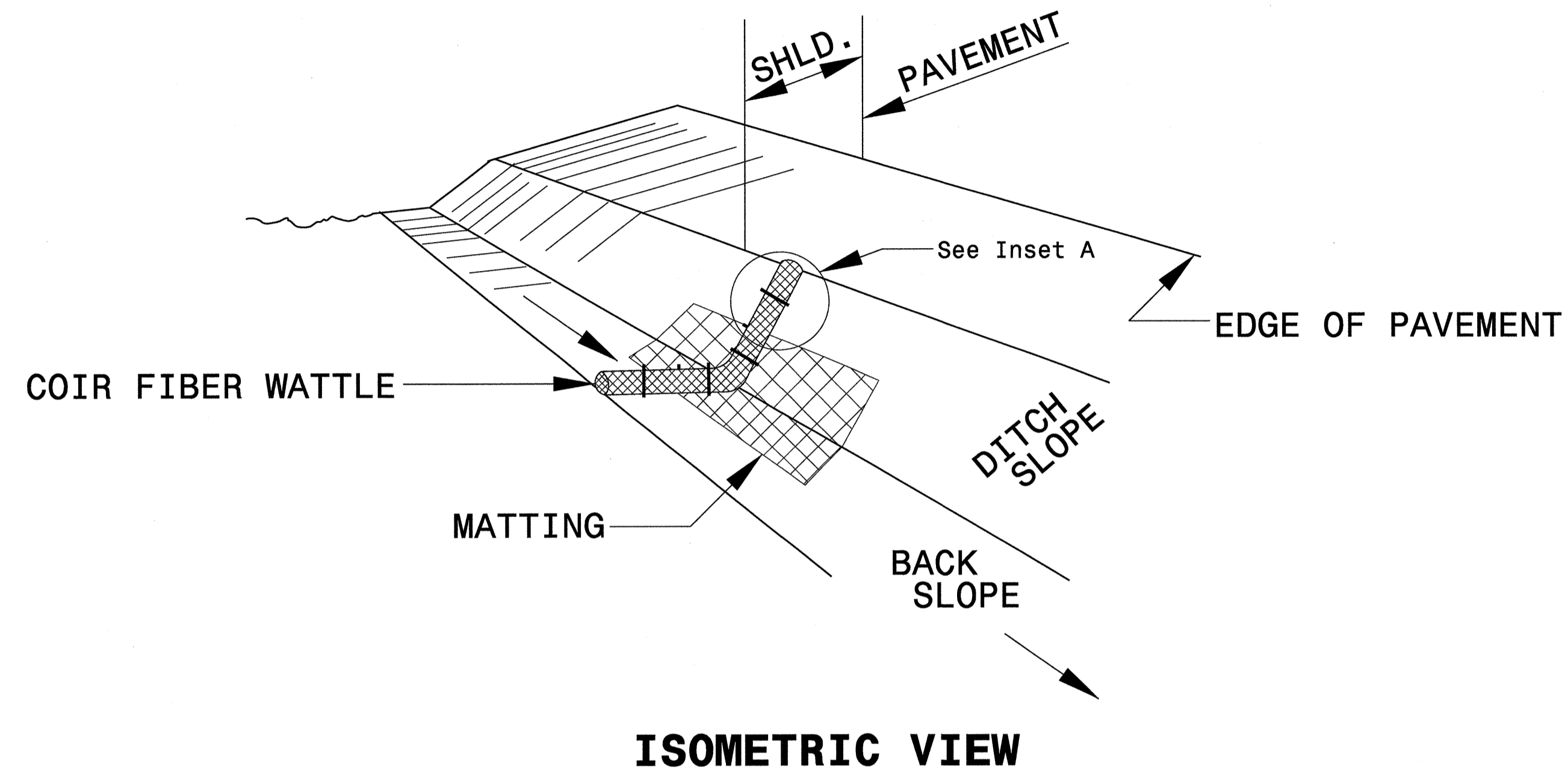

**NOTES:**

USE MINIMUM 12 IN. DIAMETER COIR FIBER (COCONUT FIBER) WATTLE.

USE 2 FT. WOODEN STAKES WITH A 2 IN. BY 2 IN. NOMINAL CROSS SECTION.

ONLY INSTALL WATTLE(S) TO A HEIGHT IN DITCH SO FLOW WILL NOT WASH AROUND WATTLE AND SCOUR DITCH SLOPES AND AS DIRECTED.

INSTALL A MINIMUM OF 2 UPSLOPE STAKES AND 4 DOWNSLOPE STAKES AT AN ANGLE TO WEDGE WATTLE TO BOTTOM OF DITCH.

PROVIDE STAPLES MADE OF 0.125 IN. DIAMETER STEEL WIRE FORMED INTO A U SHAPE NOT LESS THAN 12" IN LENGTH.

INSTALL STAPLES APPROXIMATELY EVERY 1 LINEAR FOOT ON BOTH SIDES OF WATTLE AND AT EACH END TO SECURE IT TO THE SOIL.

INSTALL MATTING IN ACCORDANCE WITH SECTION 1631 OF THE STANDARD SPECIFICATIONS.

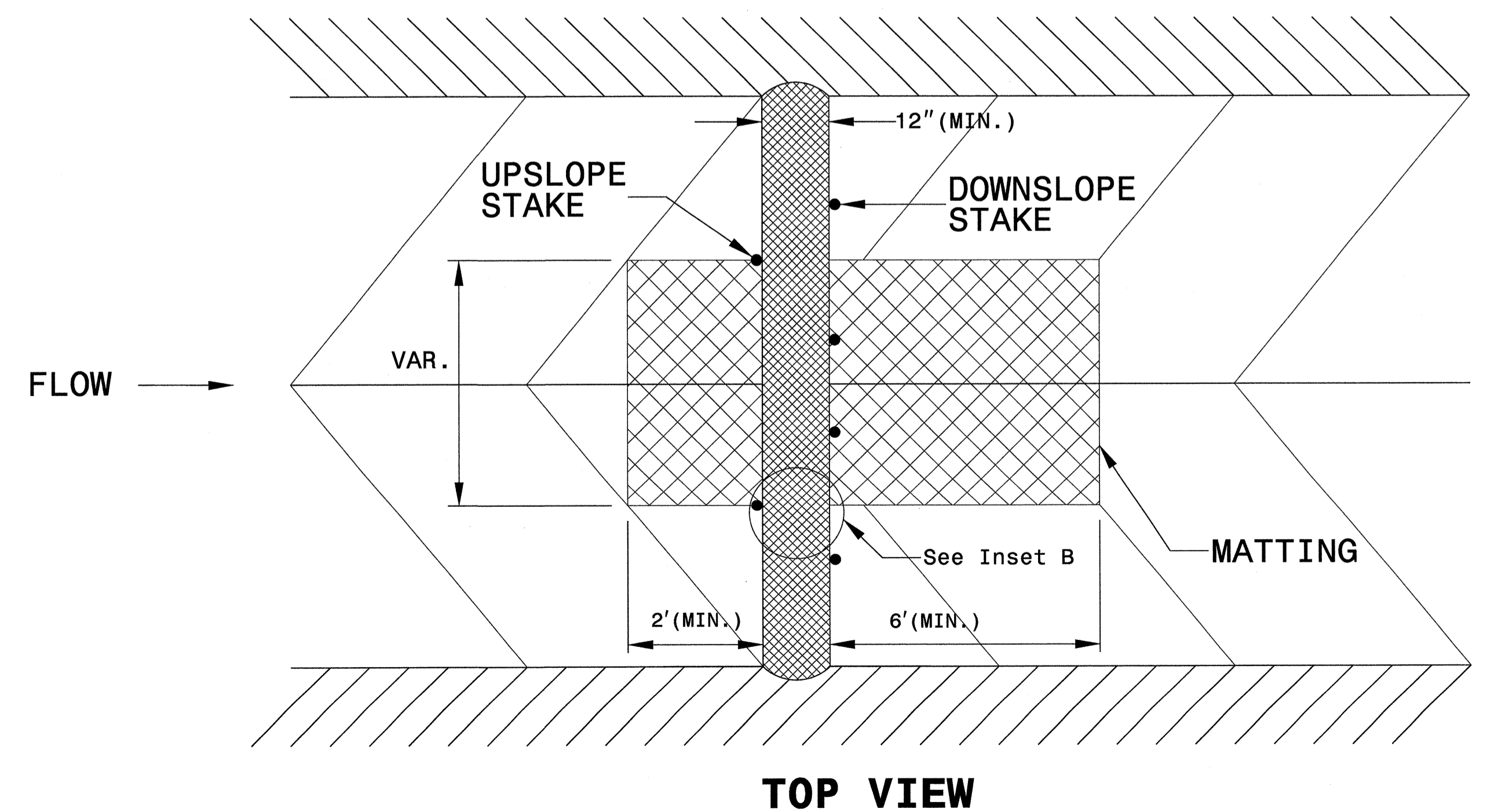
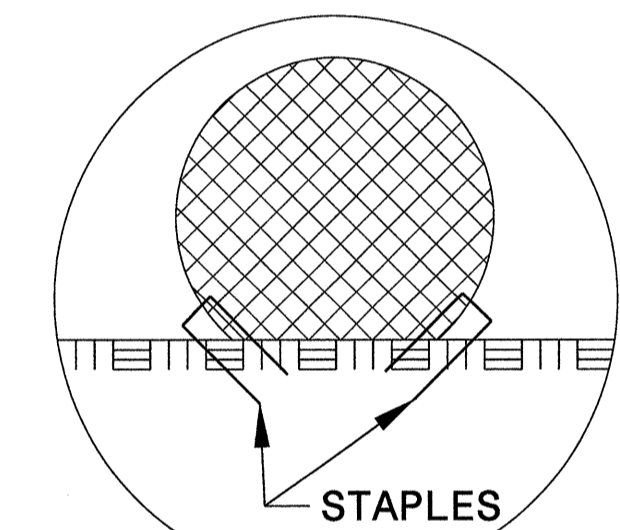
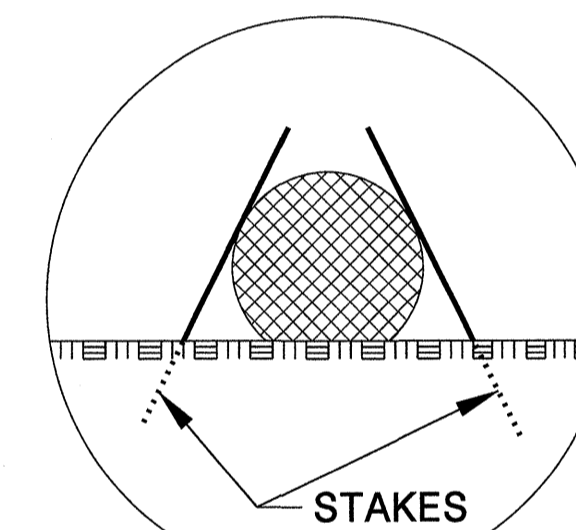

0515DEL\_P21a2



# COIR FIBER WATTLE WITH POLYACRYLAMIDE (PAM) DETAIL

PROJECT REFERENCE NO. <i>P-5208F</i>		SHEET NO. <i>EC-2A</i>	
RW SHEET NO.			
ROADWAY DESIGN ENGINEER		HYDRAULICS ENGINEER	

**NOTES:**

USE MINIMUM 12 IN. DIAMETER COIR FIBER (COCONUT FIBER) WATTLE.

USE 2 FT. WOODEN STAKES WITH A 2 IN. BY 2 IN. NOMINAL CROSS SECTION.

ONLY INSTALL WATTLE(S) TO A HEIGHT IN DITCH SO FLOW WILL NOT WASH AROUND WATTLE AND SCOUR DITCH SLOPES AND AS DIRECTED.

INSTALL A MINIMUM OF 2 UPSLOPE STAKES AND 4 DOWNSLOPE STAKES AT AN ANGLE TO WEDGE WATTLE TO BOTTOM OF DITCH.

PROVIDE STAPLES MADE OF 0.125 IN. DIAMETER STEEL WIRE FORMED INTO A U SHAPE NOT LESS THAN 12" IN LENGTH.

INSTALL STAPLES APPROXIMATELY EVERY 1 LINEAR FOOT ON BOTH SIDES OF WATTLE AND AT EACH END TO SECURE IT TO THE SOIL.

INSTALL MATTING IN ACCORDANCE WITH SECTION 1631 OF THE STANDARD SPECIFICATIONS.

PRIOR TO POLYACRYLAMIDE (PAM) APPLICATION, OBTAIN A SOIL SAMPLE FROM PROJECT LOCATION, AND FROM OFFSITE MATERIAL, AND ANALYZE FOR APPROPRIATE PAM FLOCCULANT TO BE APPLIED TO EACH WATTLE.

INITIALLY APPLY 2 OUNCES OF ANIONIC OR NEUTRALLY CHARGED PAM OVER WATTLE WHERE WATER WILL FLOW AND 1 OUNCE OF PAM ON MATTING ON EACH SIDE OF WATTLE. REAPPLY PAM AFTER EVERY RAINFALL EVENT THAT IS EQUAL TO OR EXCEEDS 0.50 IN.

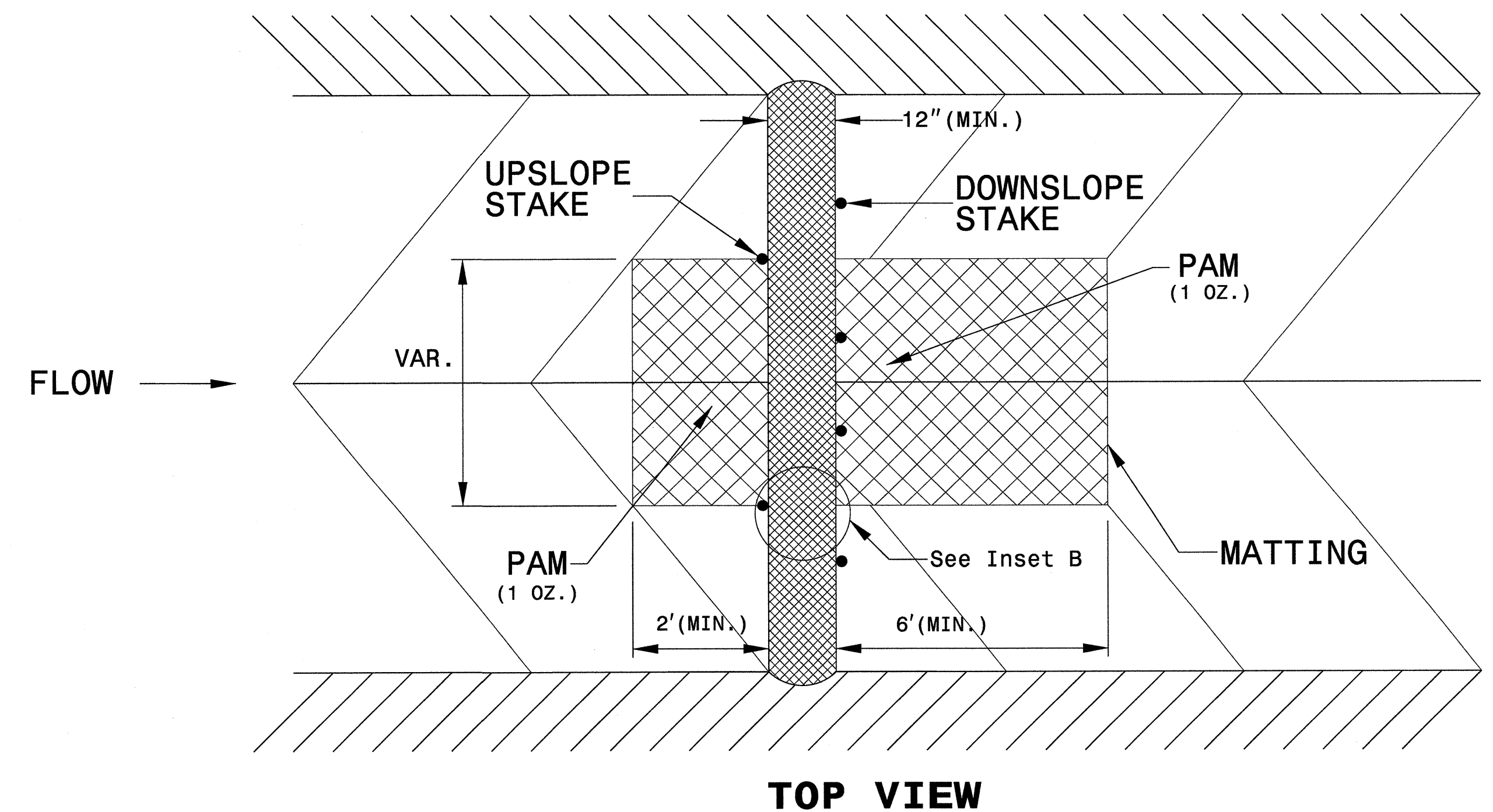
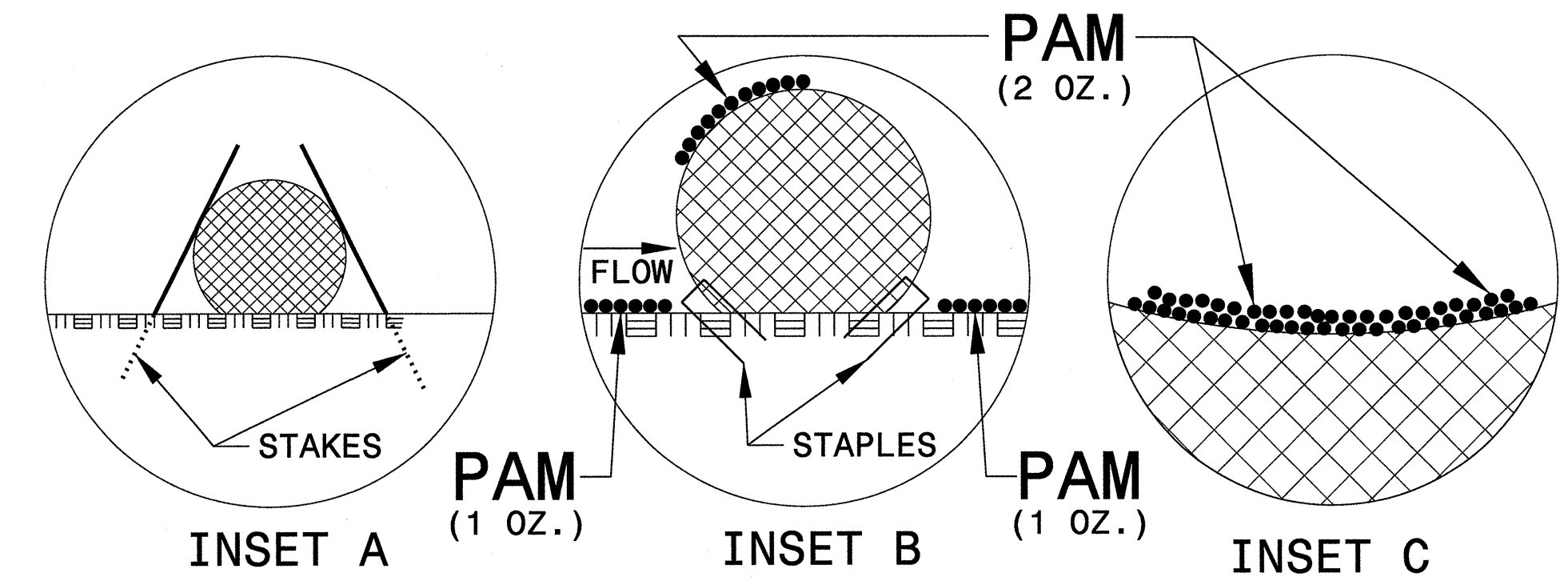
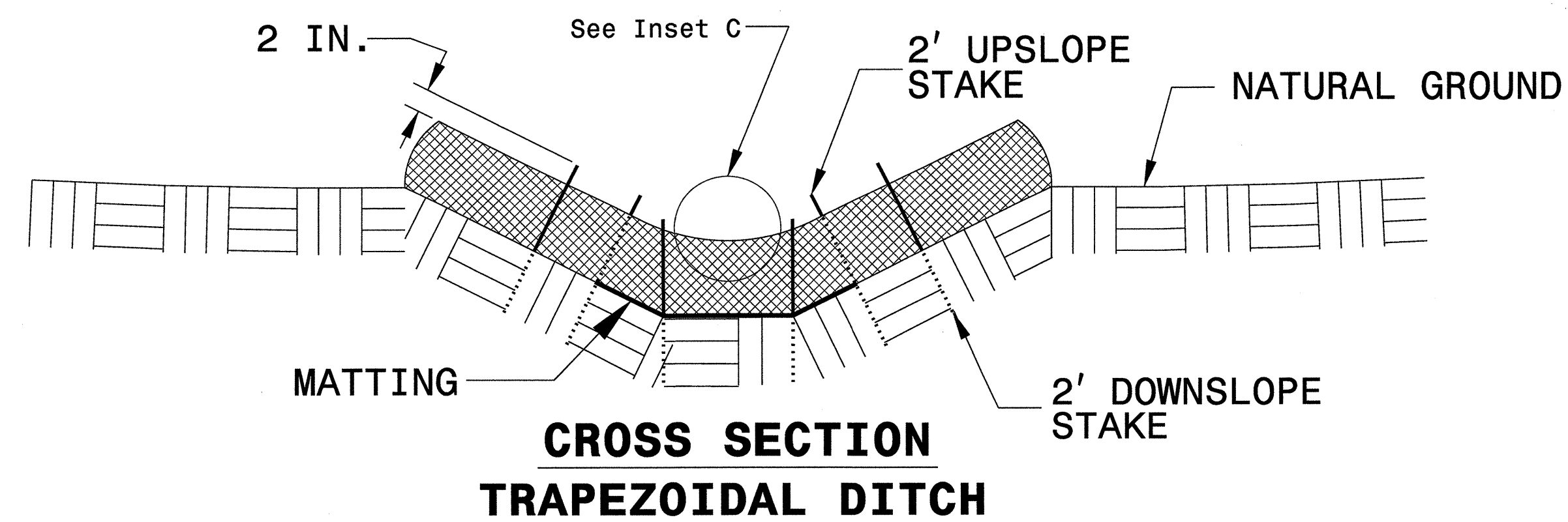
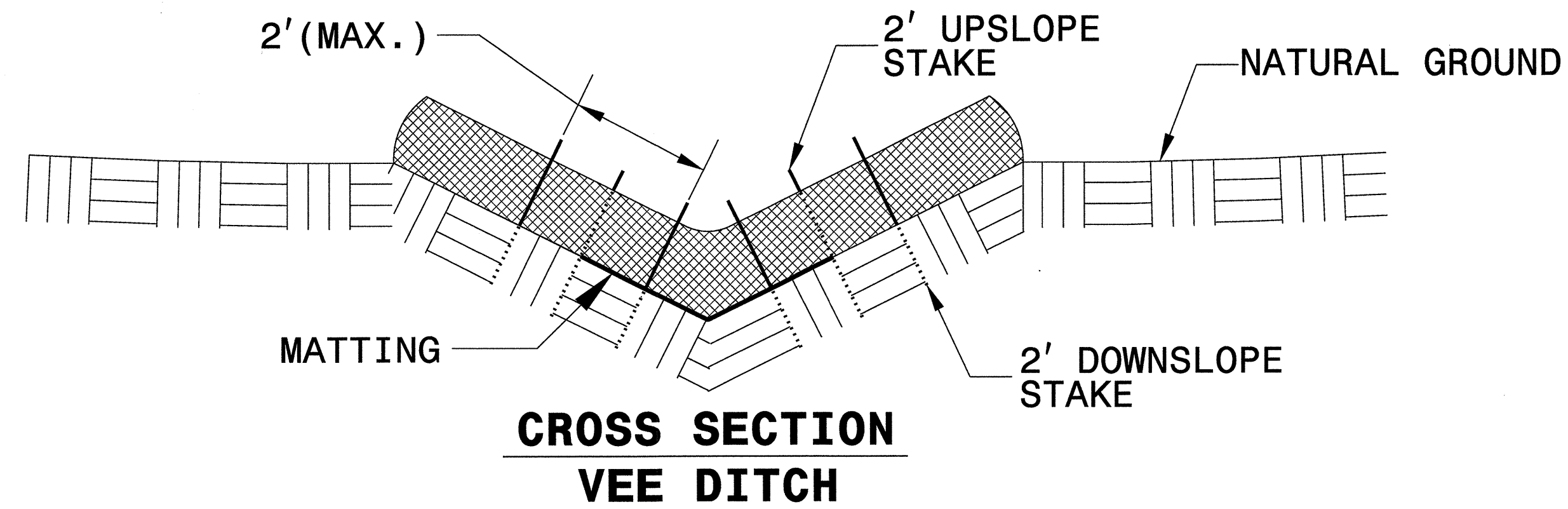
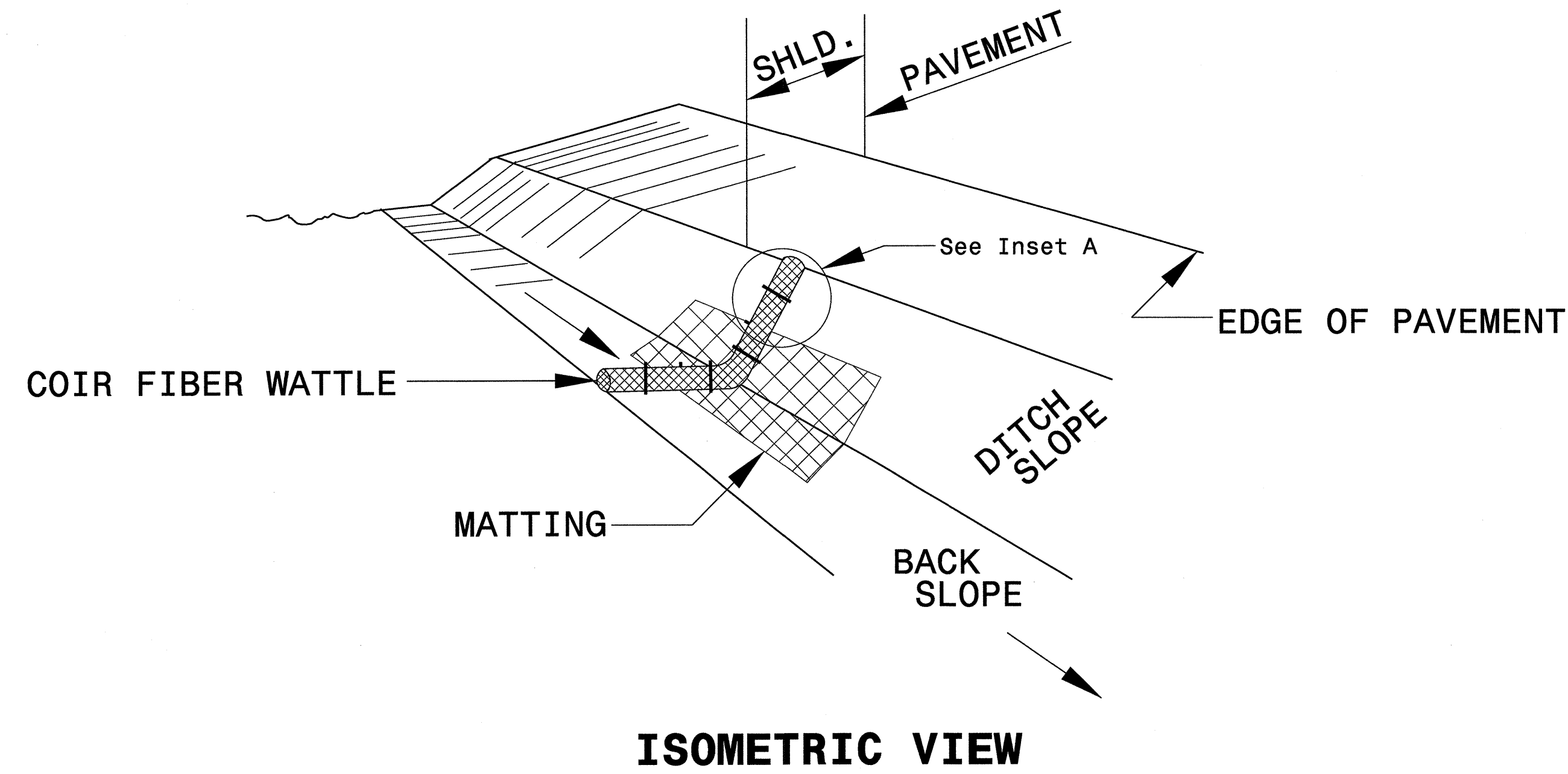

PROJECT REFERENCE NO. <i>P-5208F</i>	SHEET NO. <i>EC-2B</i>
RW SHEET NO.	
ROADWAY DESIGN ENGINEER	HYDRAULICS ENGINEER

# SKIMMER BASIN WITH BAFFLES DETAIL

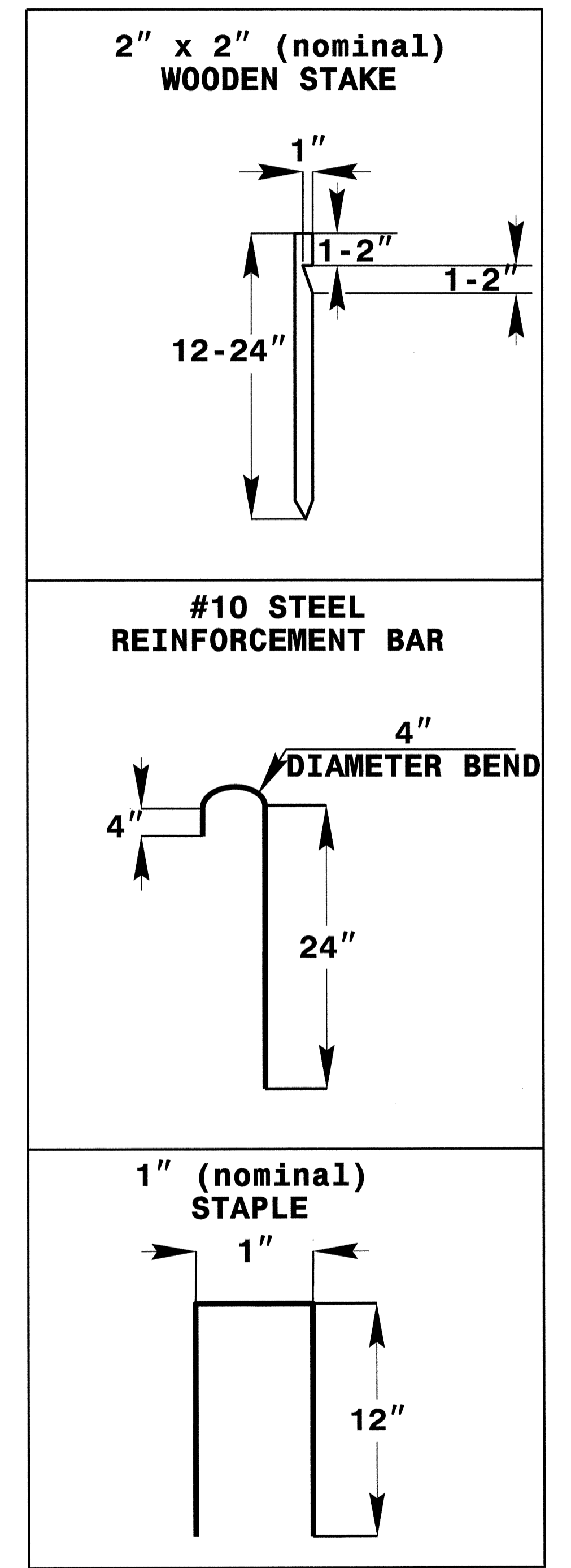
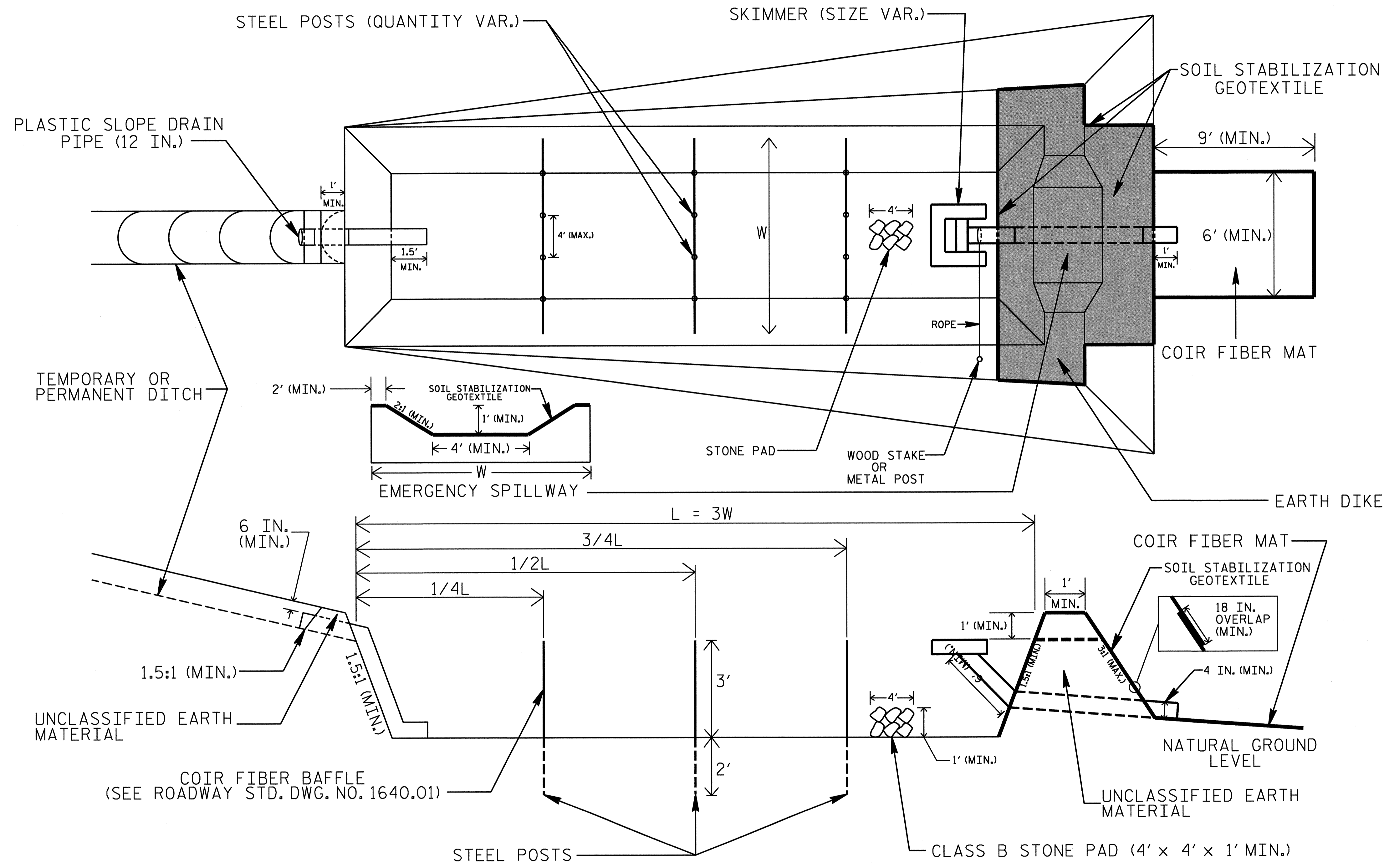

**COIR FIBER MAT ANCHOR OPTIONS**

**NOTES**

1. SEED AND PLACE MATTING FOR EROSION CONTROL ON INTERIOR AND EXTERIOR SIDESLOPES.
2. LIMIT EARTH DIKE HEIGHT TO 5 FT.
3. FOR BASIN DEPTH OF 3 FT., THE MINIMUM BASIN WIDTH SHALL BE 9 FT.
4. DETERMINE EMERGENCY SPILLWAY LENGTH (FT.) USING  $Q/0.8$ , WHERE Q IS FLOW RATE (CFS) INTO BASIN.
5. PLASTIC SLOPE DRAIN PIPE AT INLET OF BASIN MAY BE REPLACED BY FILTRATION GEOTEXTILE AS DIRECTED.
6. SOIL STABILIZATION GEOTEXTILE FOR EMERGENCY SPILLWAY SHALL BE ONE CONTINUOUS PIECE OF MATERIAL OR OVERLAPPED 18 IN. (MIN.).

NOT TO SCALE

051508L P2162



PROJECT REFERENCE NO.		SHEET NO.	
P-5208F		EC-2C	
RW SHEET NO.			
ROADWAY DESIGN ENGINEER		HYDRAULICS ENGINEER	

# SILT FENCE COIR FIBER WATTLE BREAK DETAIL

**NOTES:**

- USE MINIMUM 12 IN. DIAMETER COIR FIBER (COCONUT FIBER) WATTLE AND LENGTH OF 10 FT.
- EXCAVATE A 1 TO 2 INCH TRENCH FOR WATTLE TO BE PLACED.
- DO NOT PLACE WATTLE ON TOE OF SLOPE.
- USE 2 FT. WOODEN STAKES WITH A 2 IN. BY 2 IN. NOMINAL CROSS SECTION.
- INSTALL A MINIMUM OF 2 UPSLOPE STAKES AND 4 DOWNSLOPE STAKES AT AN ANGLE TO WEDGE WATTLE TO GROUND.
- PROVIDE STAPLES MADE OF 0.125 IN. DIAMETER STEEL WIRE FORMED INTO A U SHAPE NOT LESS THAN 12" IN LENGTH.
- INSTALL STAPLES APPROXIMATELY EVERY 1 LINEAR FOOT ON BOTH SIDES OF WATTLE AND AT EACH END TO SECURE IT TO THE SOIL.
- WATTLE INSTALLATION CAN BE ON OUTSIDE OF THE SILT FENCE AS DIRECTED.
- INSTALL TEMPORARY SILT FENCE IN ACCORDANCE WITH SECTION 1605 OF THE STANDARD SPECIFICATIONS.

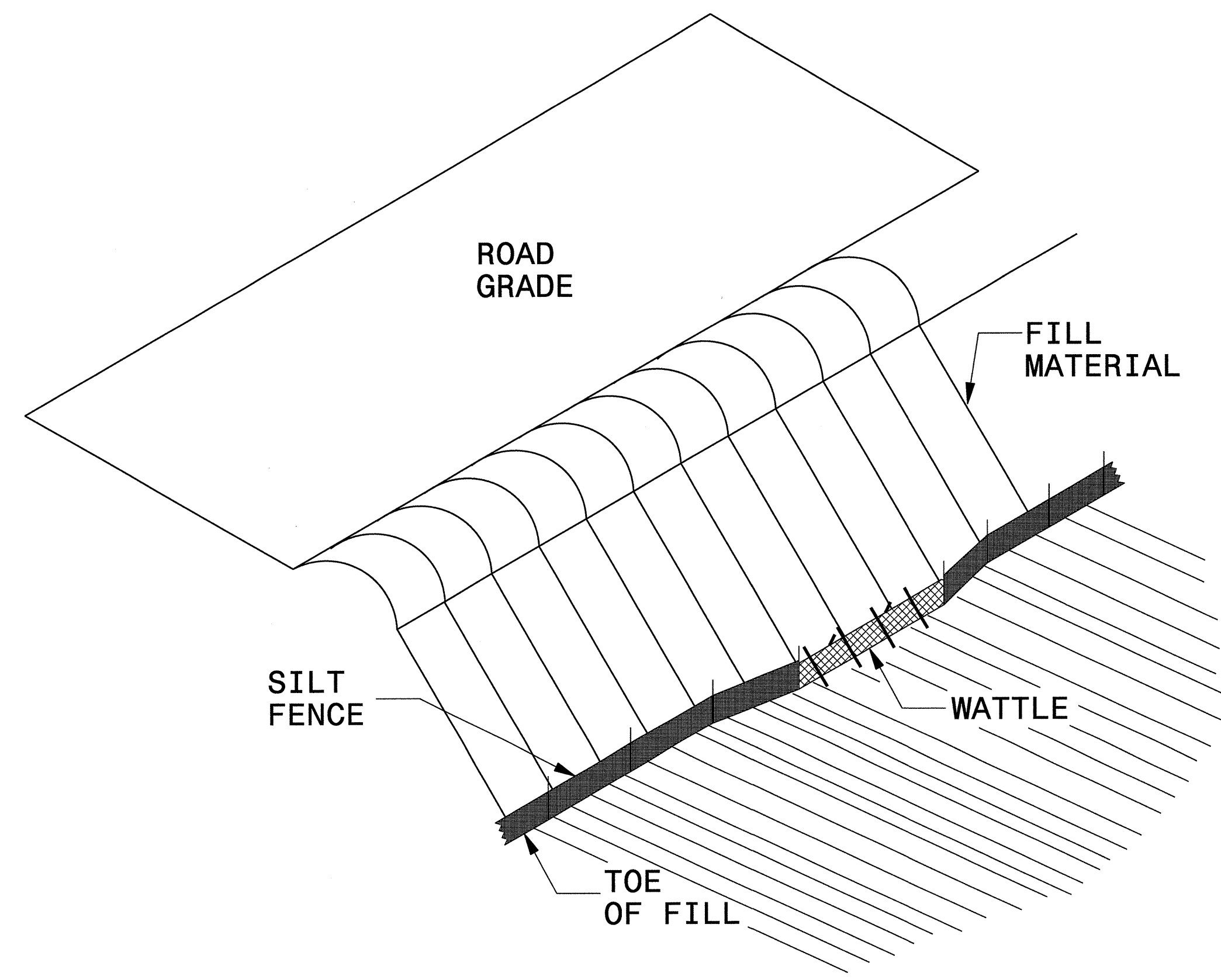

**ISOMETRIC VIEW**

**INSET A**

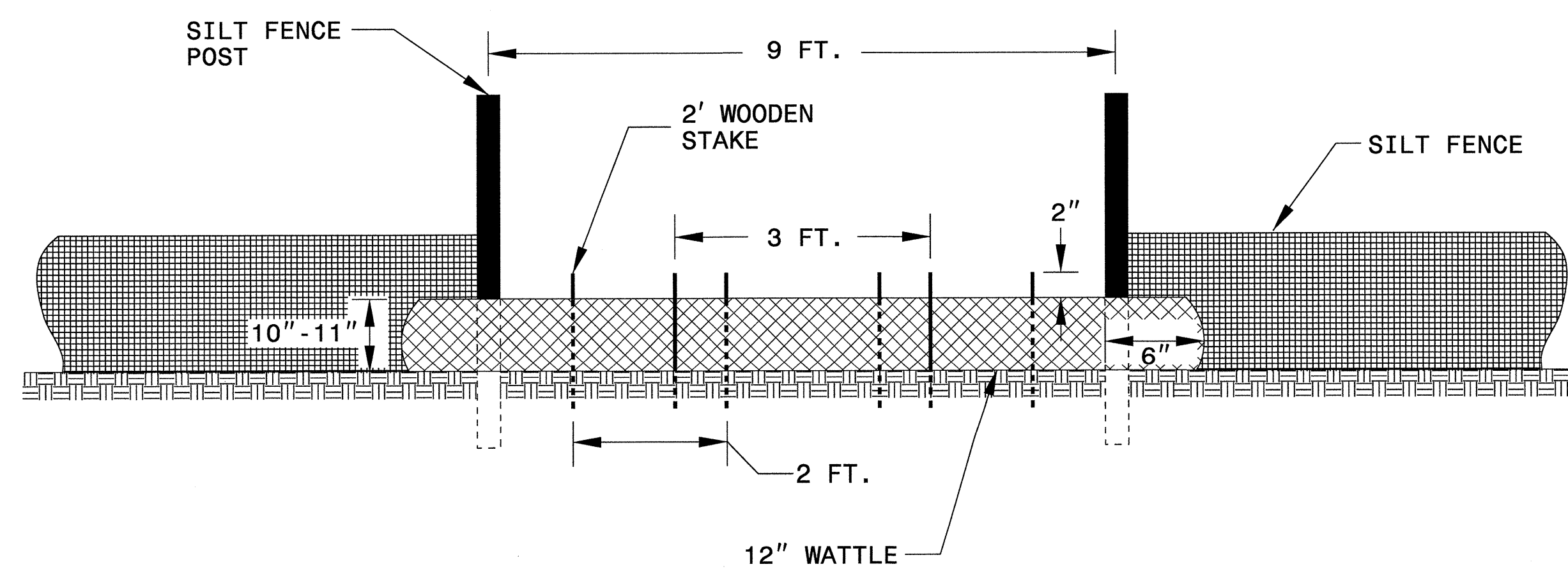
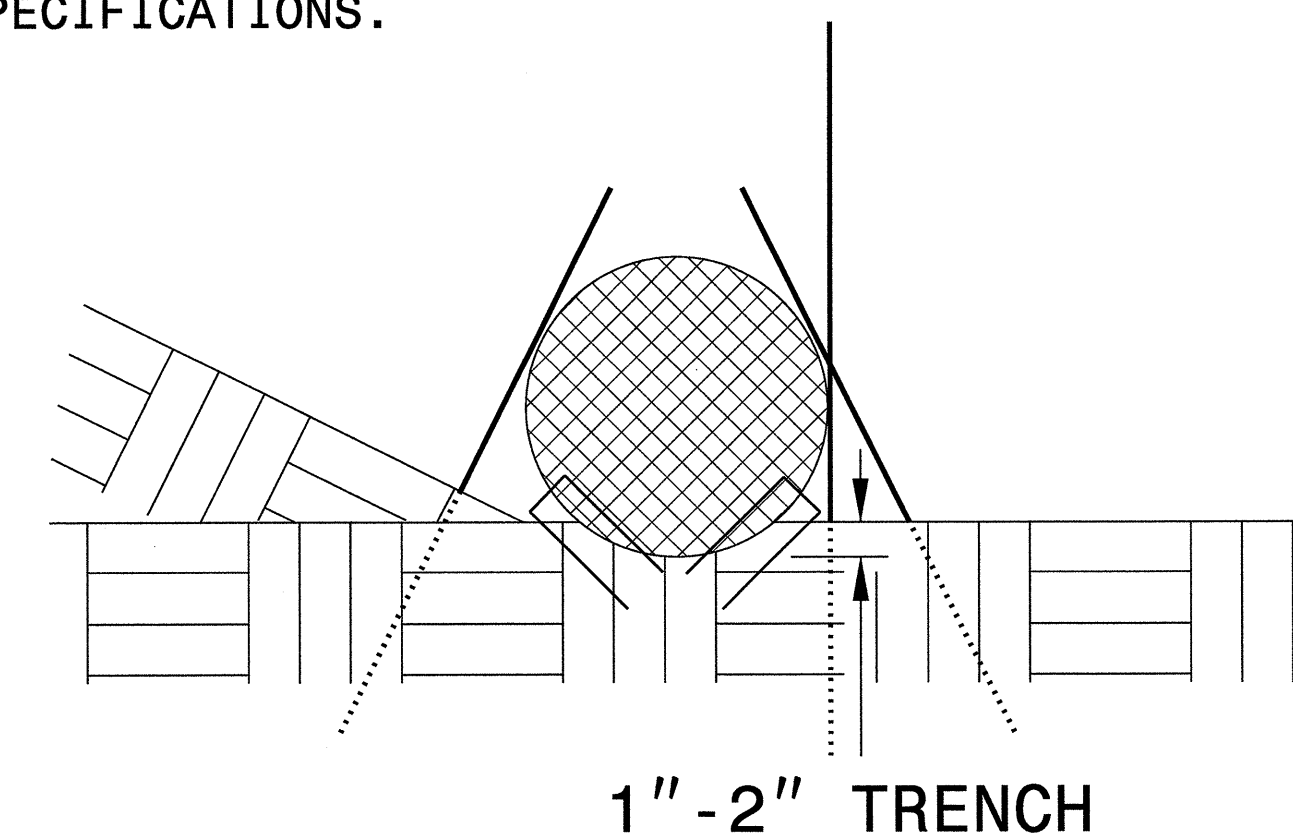

**VIEW FROM SLOPE**

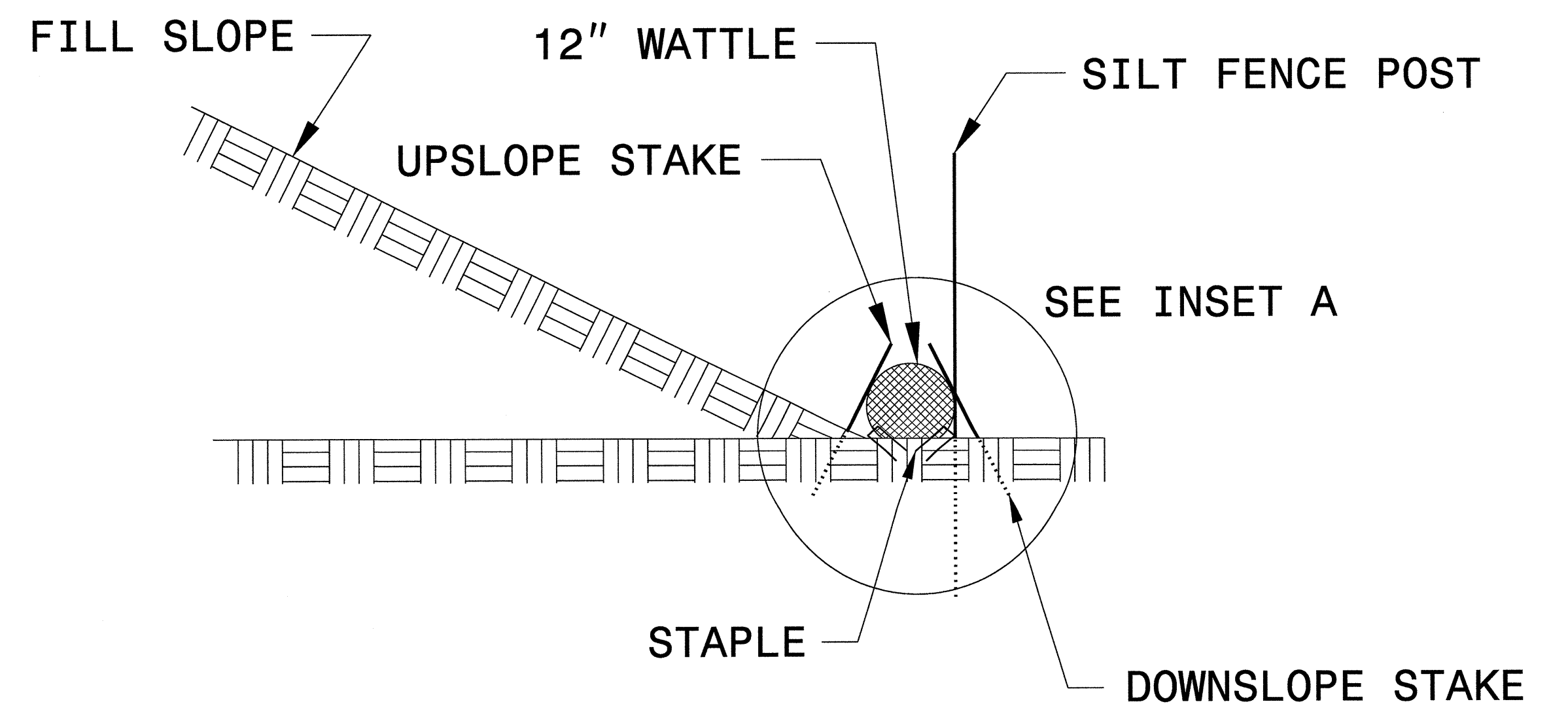

**SIDE VIEW**

0515DEL\_P21a2

DIVISION OF HIGHWAYS  
STATE OF NORTH CAROLINA

PROJECT REFERENCE NO. <i>P-5208F</i>	SHEET NO. <i>EC-3</i>
ROADWAY DESIGN ENGINEER	HYDRAULICS ENGINEER

## SOIL STABILIZATION SUMMARY SHEET

### MATTING FOR EROSION CONTROL (DITCHES)

CONST SHEET NO.	LINE	FROM STATION	TO STATION	SIDE	ESTIMATE (SY)
4	-L-	12+79	13+48	RT	95
5	-L-	28+00	29+00	RT	65
5		30+93	33+50	RT	180
			SUBTOTAL		340

### MATTING FOR EROSION CONTROL (SLOPES)

4 & 5	-L-	17+43	25+00	RT	4735
5	-L-	28+00	30+00	RT	1032
4 & 5	-L-	18+50	25+00	LT	2228
5	-L-	28+00	32+50	LT	1203
			SUBTOTAL		9198
MISCELLANEOUS MATTING TO BE INSTALLED AS DIRECTED BY THE ENGINEER					500
			TOTAL		10038
			SAY		10440

### PERMANENT SOIL REINFORCEMENT MAT (DITCHES)

CONST SHEET NO.	LINE	FROM STATION	TO STATION	SIDE	ESTIMATE (SY)
4	L	13+48	16+00	RT	350
4	L	13+48	16+00	LT	350
5	L	24+42	26+00	RT	325
5	L	27+50	28+50	LT	125
5	L	28+50	30+50	LT	290
			SUBTOTAL		1440
			ADDITIONAL PRGM TO BE INSTALLED		140
			TOTAL		1580
			SAY		1600

PROJECT REFERENCE NO. <i>P-5208F</i>	SHEET NO. <i>EC-3A</i>
ROADWAY DESIGN ENGINEER	HYDRAULICS ENGINEER

DIVISION OF HIGHWAYS  
STATE OF NORTH CAROLINA

# ***SOIL STABILIZATION TIMEFRAMES***

<i>SITE DESCRIPTION</i>	<i>STABILIZATION TIME</i>	<i>TIMEFRAME EXCEPTIONS</i>
PERIMETER DIKES, SWALES, DITCHES AND SLOPES	7 DAYS	NONE
HIGH QUALITY WATER (HQW) ZONES	7 DAYS	NONE
SLOPES STEEPER THAN 3:1	7 DAYS	IF SLOPES ARE 10' OR LESS IN LENGTH AND ARE NOT STEEPER THAN 2:1, 14 DAYS ARE ALLOWED.
SLOPES 3:1 OR FLATTER	14 DAYS	7 DAYS FOR SLOPES GREATER THAN 50' IN LENGTH.
ALL OTHER AREAS WITH SLOPES FLATTER THAN 4:1	14 DAYS	NONE, EXCEPT FOR PERIMETERS AND HQW ZONES.

0515DBL P21.02

DGN



NAD 83/NSRS 2007

CLEARING AND GRUBBING  
EROSION CONTROL FOR  
CONSTRUCTION SHEET 4

**ETHERILL ENGINEERING**  
559 Jones Franklin Rd. Suite 164  
Raleigh, N.C. 27606  
License No. F-0377  
Bus: 919 851 8077  
Fax: 919 851 8107  
TRANSPORTATION PLANNING/DESIGN - BRIDGE/STRUCTURE DESIGN  
CIVIL/SITE DESIGN - GIS/GPS - CONSTRUCTION OBSERVATION

PROJECT REFERENCE NO. <b>P-5208F</b>		SHEET NO. <b>EC-4/CONST4</b>	
RW SHEET NO.			
ROADWAY DESIGN ENGINEER		HYDRAULICS ENGINEER	

- NOTE: PLACE TEMPORARY ROCK SEDIMENT DAMS TYPE - B AND TEMPORARY ROCK SILT CHECKS TYPE - A AT DRAINAGE OUTLETS.
- NOTE: PERIMETER EROSION CONTROL MEASURES SHALL BE INSTALLED DURING CLEARING AND GRUBBING PHASE.

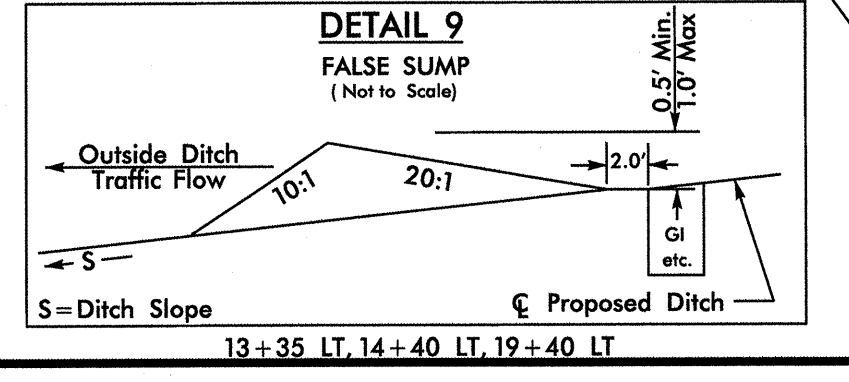
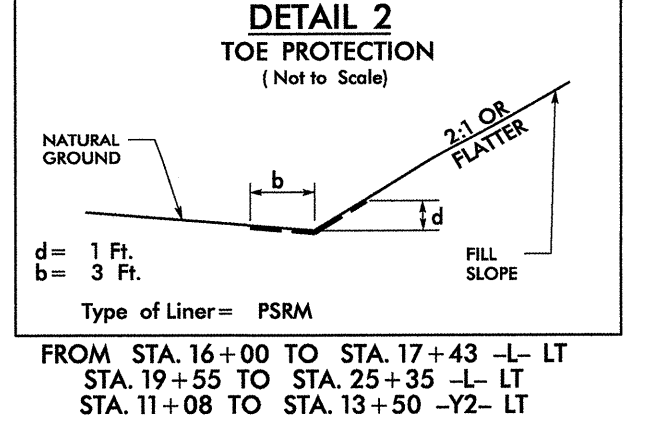
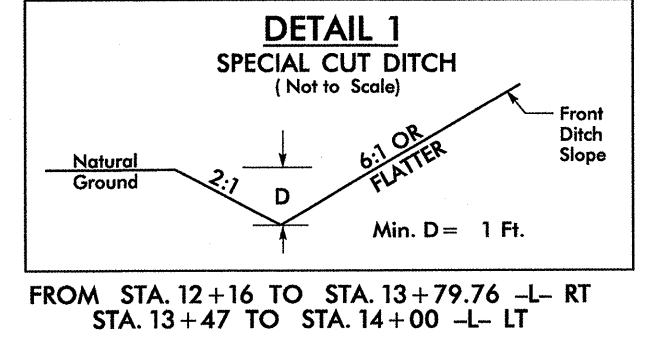
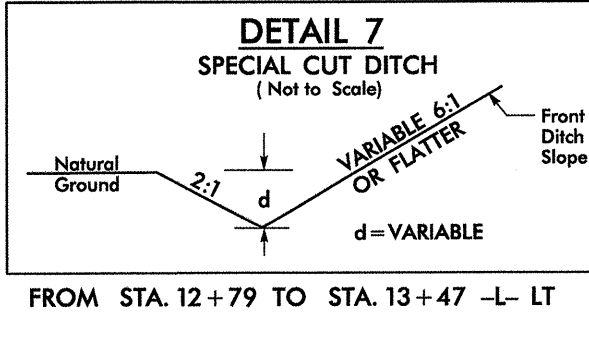
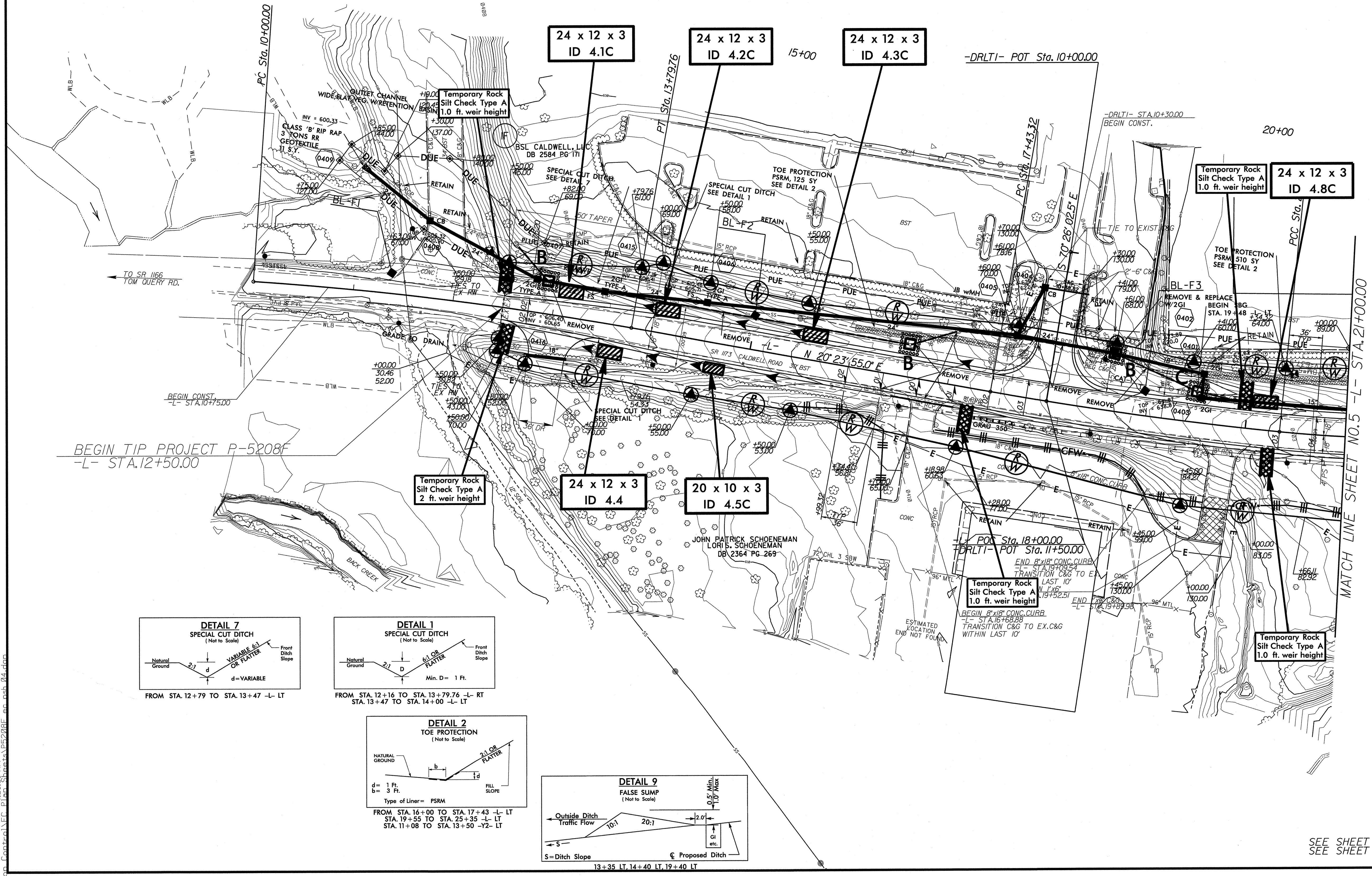

SEE SHEET 7 FOR -L- PROFILE  
SEE SHEET 9 FOR -DRLTI- PROFILE

2/18/2013 9:01:31 AM  
E:\osdon\Control\EC\_Plan\_Sheets\P5208F.ec.dwg



0515DEL P21a2

CLEARING AND GRUBBING  
EROSION CONTROL FOR  
CONSTRUCTION SHEET 5

NOTE:  
PLACE TEMPORARY ROCK SEDIMENT DAMS TYPE - B  
AND TEMPORARY ROCK SILT CHECKS TYPE - A AT  
DRAINAGE OUTLETS.

NOTE:  
PERIMETER EROSION CONTROL MEASURES SHALL BE  
INSTALLED DURING CLEARING AND GRUBBING PHASE.

**ETHERILL ENGINEERING**  
TRANSPORTATION PLANNING/DESIGN - BRIDGE/STRUCTURE DESIGN  
CIVIL/SITE DESIGN - GIS/GPS - CONSTRUCTION OBSERVATION  
559 Jones Franklin Rd. Suite 164  
Raleigh, N.C. 27606  
License No. F-0377  
Bus: 919 851 8077  
Fax: 919 851 8107

PROJECT REFERENCE NO. **P-5208F**  
SHEET NO. **EC-5/CONST.5**

RW SHEET NO. **ROADWAY DESIGN ENGINEER**  
HYDRAULICS ENGINEER

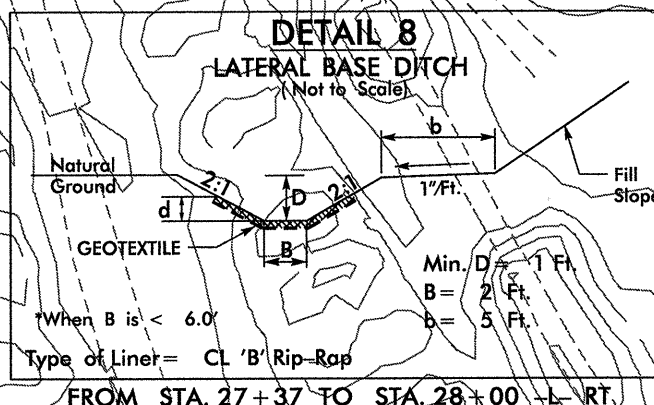
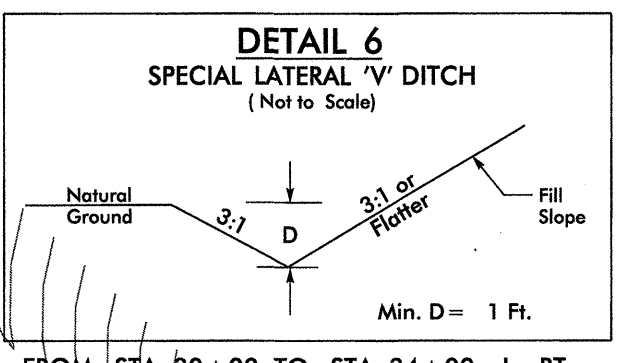
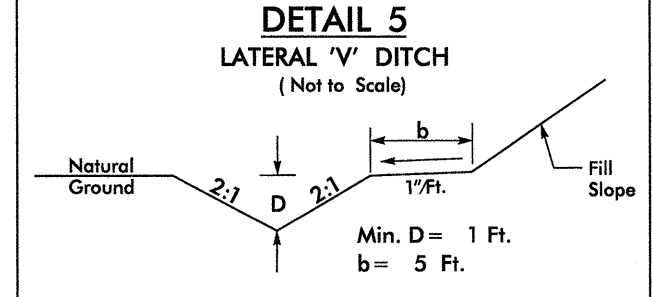
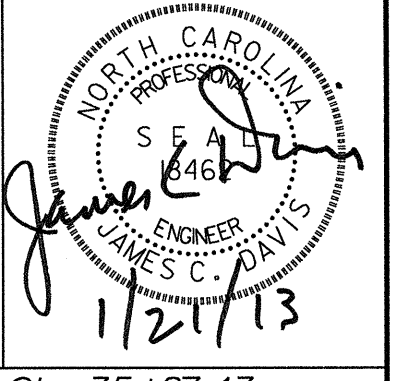

**NAD 83/NSRS 2007**

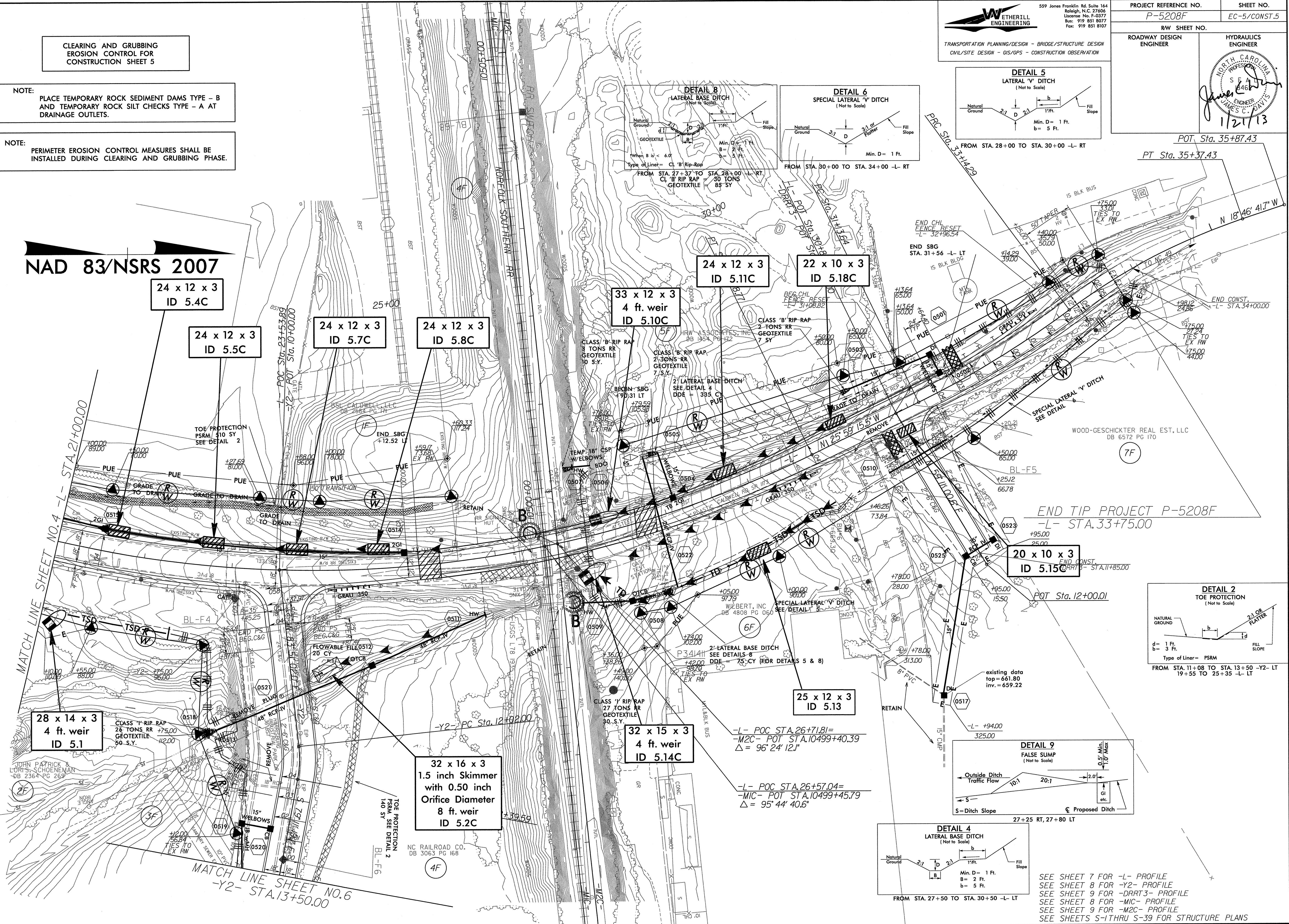

END TIP PROJECT P-5208F  
-L- STA. 33+75.00

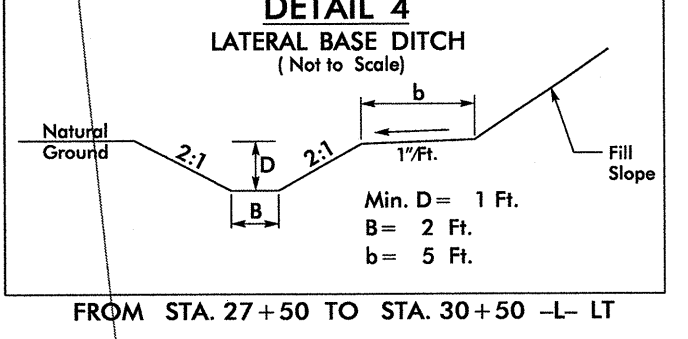
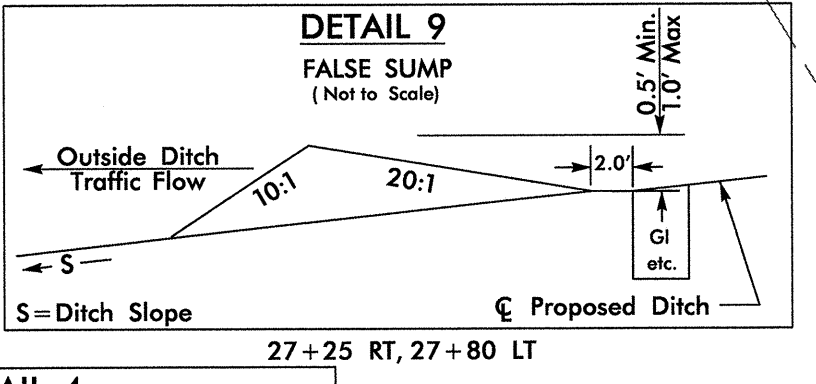
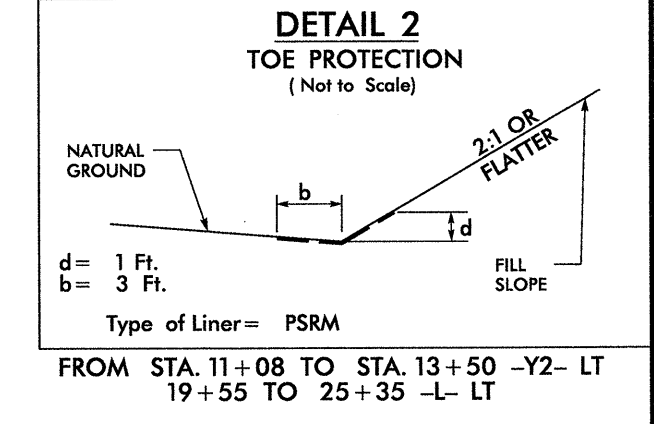

SEE SHEET 7 FOR -L- PROFILE  
SEE SHEET 8 FOR -Y2- PROFILE  
SEE SHEET 9 FOR -DRRT3- PROFILE  
SEE SHEET 8 FOR -MIC- PROFILE  
SEE SHEET 9 FOR -M2C- PROFILE  
SEE SHEETS S-1 THRU S-39 FOR STRUCTURE PLANS

P-5208F EC-5/CONST.5.dgn  
1/26/13 PM  
Control\EC Plan Sheets\PE5208F\_ec\_psh\_05.dgn



0515DEL P21a2

CLEARING AND GRUBBING  
EROSION CONTROL FOR  
CONSTRUCTION SHEET 6

NOTE:  
PLACE TEMPORARY ROCK SEDIMENT DAMS TYPE - B  
AND TEMPORARY ROCK SILT CHECKS TYPE - A AT  
DRAINAGE OUTLETS.

NOTE:  
PERIMETER EROSION CONTROL MEASURES SHALL BE  
INSTALLED DURING CLEARING AND GRUBBING PHASE.

NAD 83/NSRS 2007

ETHERILL  
ENGINEERING  
559 Jones Franklin Rd. Suite 164  
Raleigh, N.C. 27606  
License No. F-0377  
Bus: 919 851 8077  
Fax: 919 851 8107  
TRANSPORTATION PLANNING/DESIGN - BRIDGE/STRUCTURE DESIGN  
CIVIL/SITE DESIGN - GIS/GPS - CONSTRUCTION OBSERVATION

PROJECT REFERENCE NO. P-5208F	SHEET NO. EC-6/CONST.6
R/W SHEET NO.	HYDRAULICS ENGINEER
ROADWAY DESIGN ENGINEER	

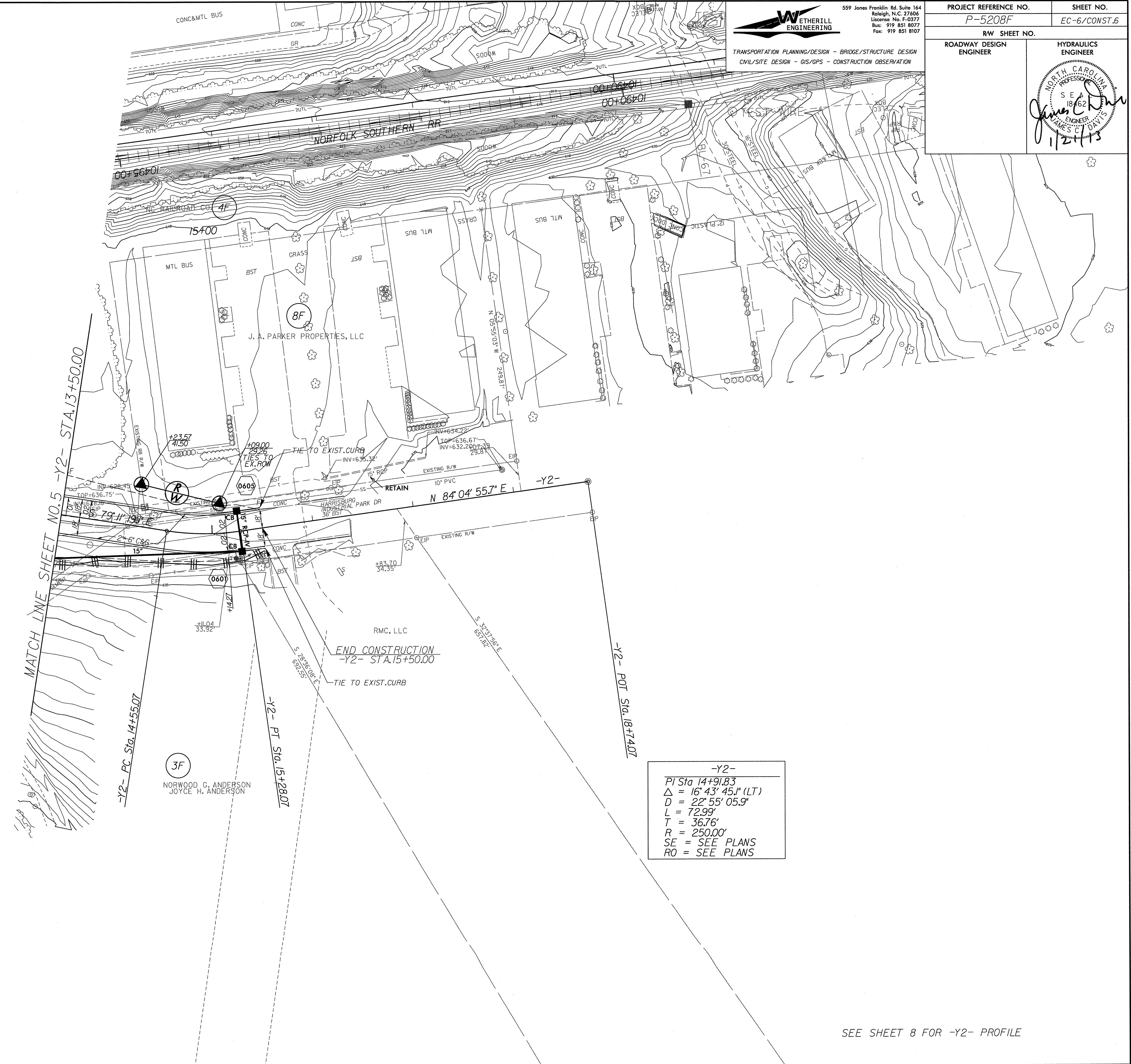

SEE SHEET 8 FOR -Y2- PROFILE



0515DEL P21a2

NAD 83/NSRS 2007

INSTALL MATTING FOR EROSION CONTROL IN THE PROPOSED DITCH LINE AT THE FOLLOWING LOCATIONS: STA. 12+79 TO STA. 13+48 -L- RT.

Place Matting for Erosion Control on Slope as Work Allows.

INSTALL PSRM IN THE PROPOSED DITCH LINE AT THE FOLLOWING LOCATIONS: STA. 13+48 TO STA. 16+00 -L- RT. STA. 13+48 TO STA. 16+00 -L- LT.

ETHERILL ENGINEERING  
559 Jones Franklin Rd. Suite 164  
Raleigh, N.C. 27606  
License No. F-4377  
Bus: 919 851 8077  
Fax: 919 851 8107  
TRANSPORTATION PLANNING/DESIGN - BRIDGE/STRUCTURE DESIGN  
CIVIL/SITE DESIGN - GIS/GPS - CONSTRUCTION OBSERVATION

PROJECT REFERENCE NO. P-5208F	SHEET NO. EC-7/CONST.4
RW SHEET NO.	
ROADWAY DESIGN ENGINEER	HYDRAULICS ENGINEER

Professional Engineer Seal: NORTH CAROLINA PROFESSIONAL ENGINEER JAMES C. DAVIS 21913

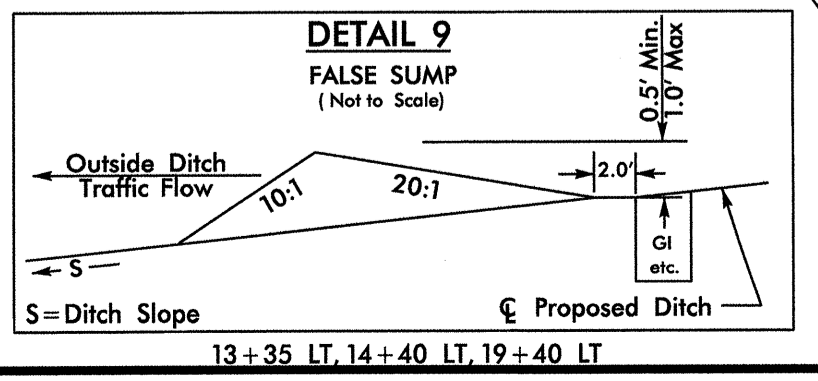
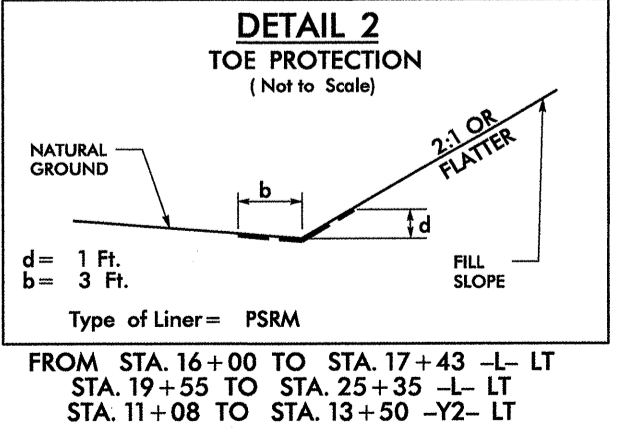
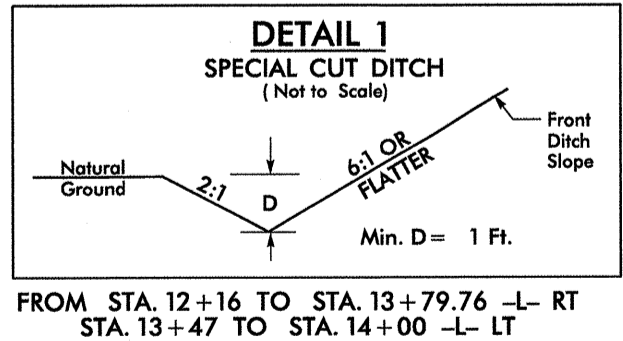
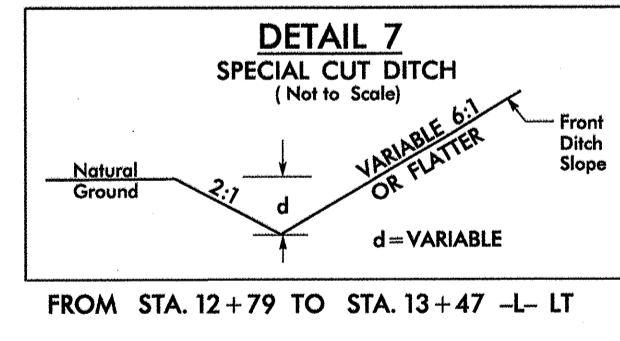
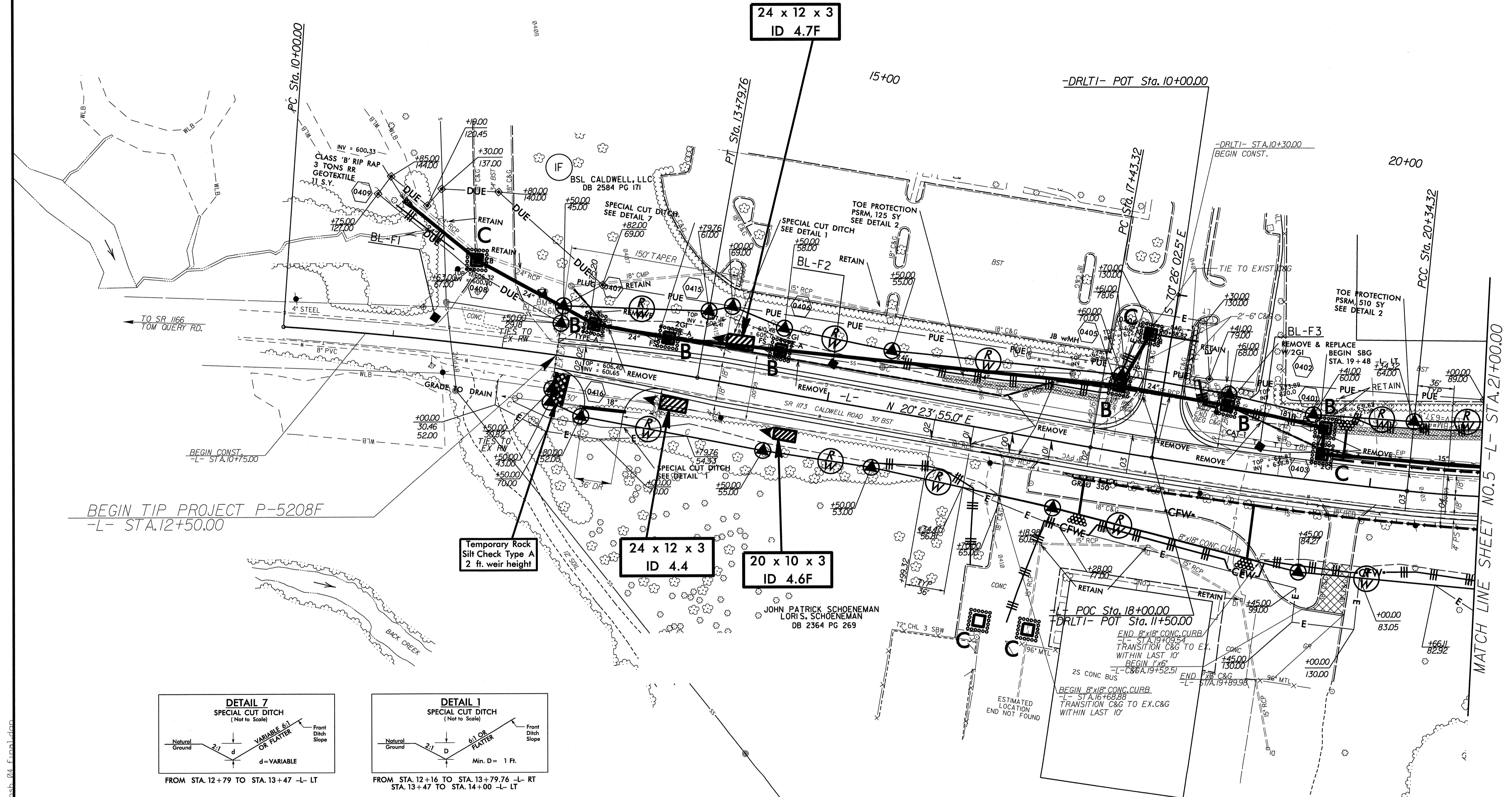

Sta 25+29.02  
= 42' 06" 40.1" (LT)  
= 4' 27" 31.7"  
= 944.45'  
= 494.70'  
= 1,285.00'  
= SEE PLANS

SEE SHEET 7 FOR -L- PROFILE  
SEE SHEET 9 FOR -DRLT- PROFILE

2/18/2013 9:04:30 AM  
Control/EC\_Plan\_Sheets/5208F.ec.dwg 04 Final.dwg



Place Matting for Erosion Control on Slope as Work Allows.

INSTALL PSRM IN THE PROPOSED DITCH LINE AT THE FOLLOWING LOCATIONS:  
 STA. 24+42 TO STA. 26+00 -L- RT.  
 STA. 27+50 TO STA. 30+50 -L- LT.

INSTALL MATTING FOR EROSION CONTROL IN THE PROPOSED DITCH LINE AT THE FOLLOWING LOCATIONS:  
 STA. 28+00 TO STA. 29+00 -L- RT.  
 STA. 30+93 TO STA. 33+50 -L- RT.

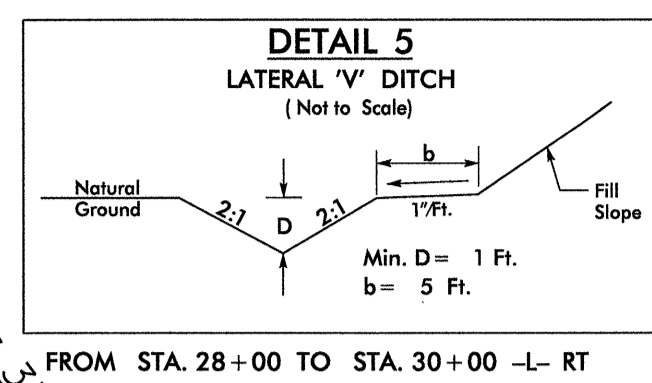
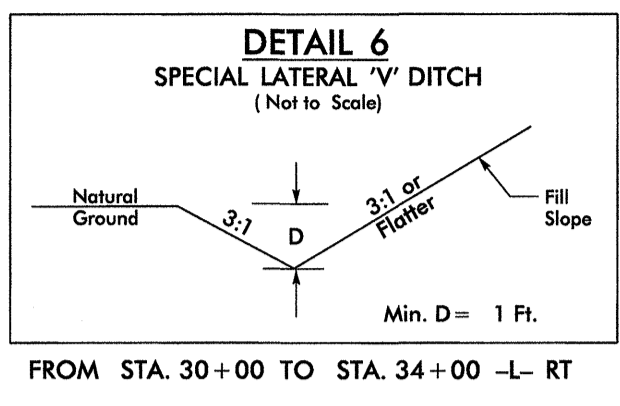
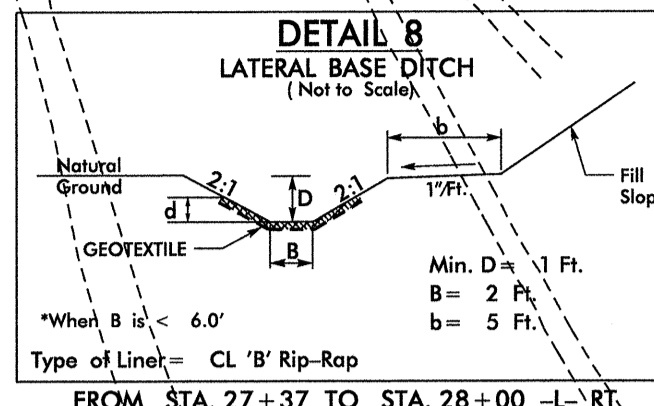

POT Sta. 35+87.43  
 PT Sta. 35+37.43

NAD 83/NSRS 2007

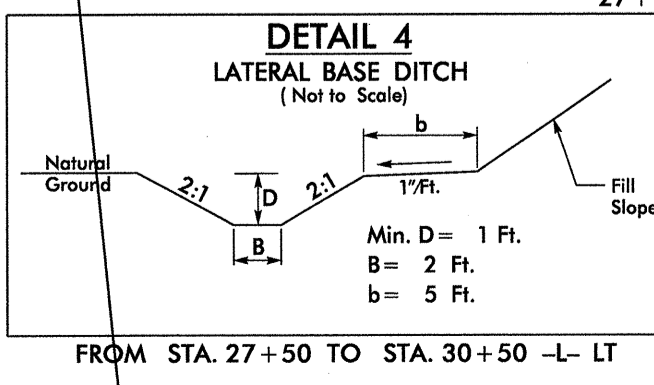
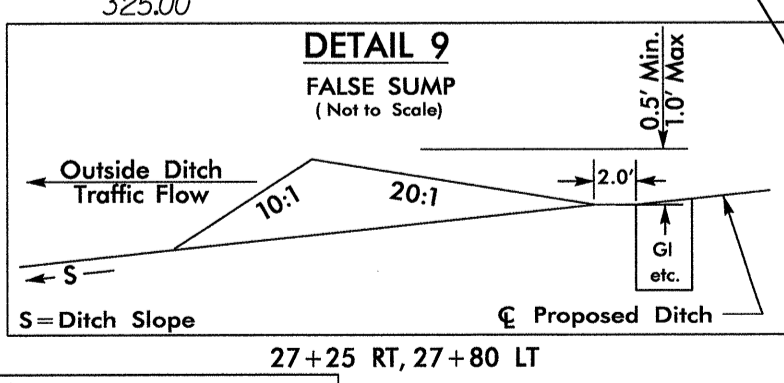
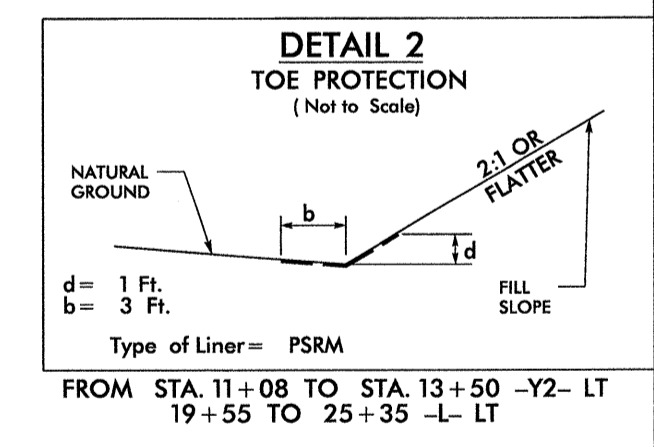
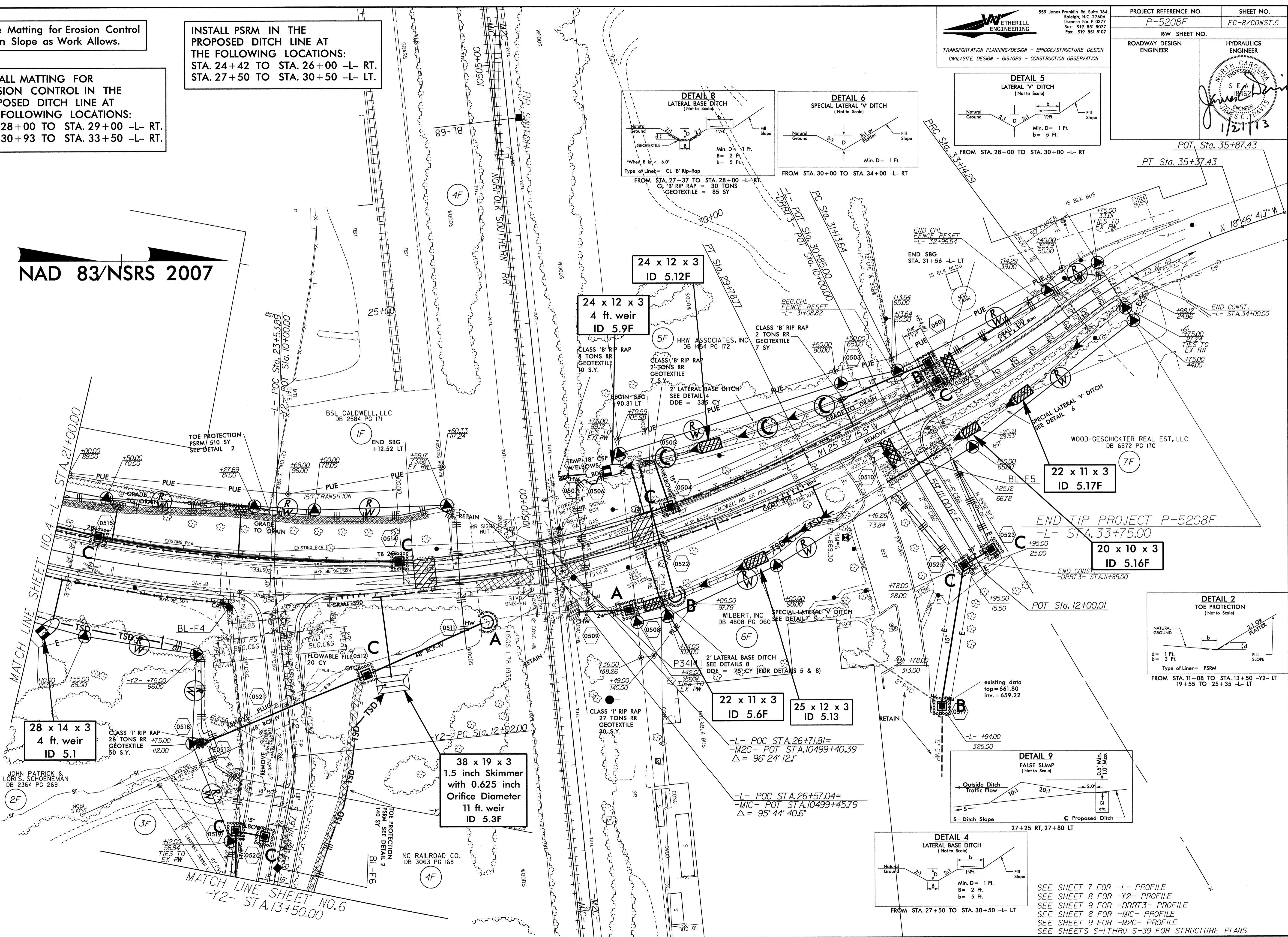

SEE SHEET 7 FOR -L- PROFILE  
 SEE SHEET 8 FOR -Y2- PROFILE  
 SEE SHEET 9 FOR -DRRT3- PROFILE  
 SEE SHEET 8 FOR -MIC- PROFILE  
 SEE SHEET 9 FOR -M2C- PROFILE  
 SEE SHEETS S-1 THRU S-39 FOR STRUCTURE PLANS

0515DEL P21a2

1/29/24 PM  
 2088\Er-95077\_2013\Drawings\EC Plan Sheets\PE208F-ec-psht\_05.f.mai.dgn



0515DEL P21a2

Place Matting for Erosion Control on Slope as Work Allows.

NAD 83/NSRS 2007

ETHERILL ENGINEERING  
559 Jones Franklin Rd. Suite 164  
Raleigh, N.C. 27606  
License No. F-8377  
Bus: 919 851 8077  
Fax: 919 851 8107  
TRANSPORTATION PLANNING/DESIGN - BRIDGE/STRUCTURE DESIGN  
CIVIL/SITE DESIGN - GIS/GPS - CONSTRUCTION OBSERVATION

PROJECT REFERENCE NO. P-5208F		SHEET NO. EC-9/CONST.6	
RW SHEET NO.		HYDRAULICS ENGINEER	
ROADWAY DESIGN ENGINEER			

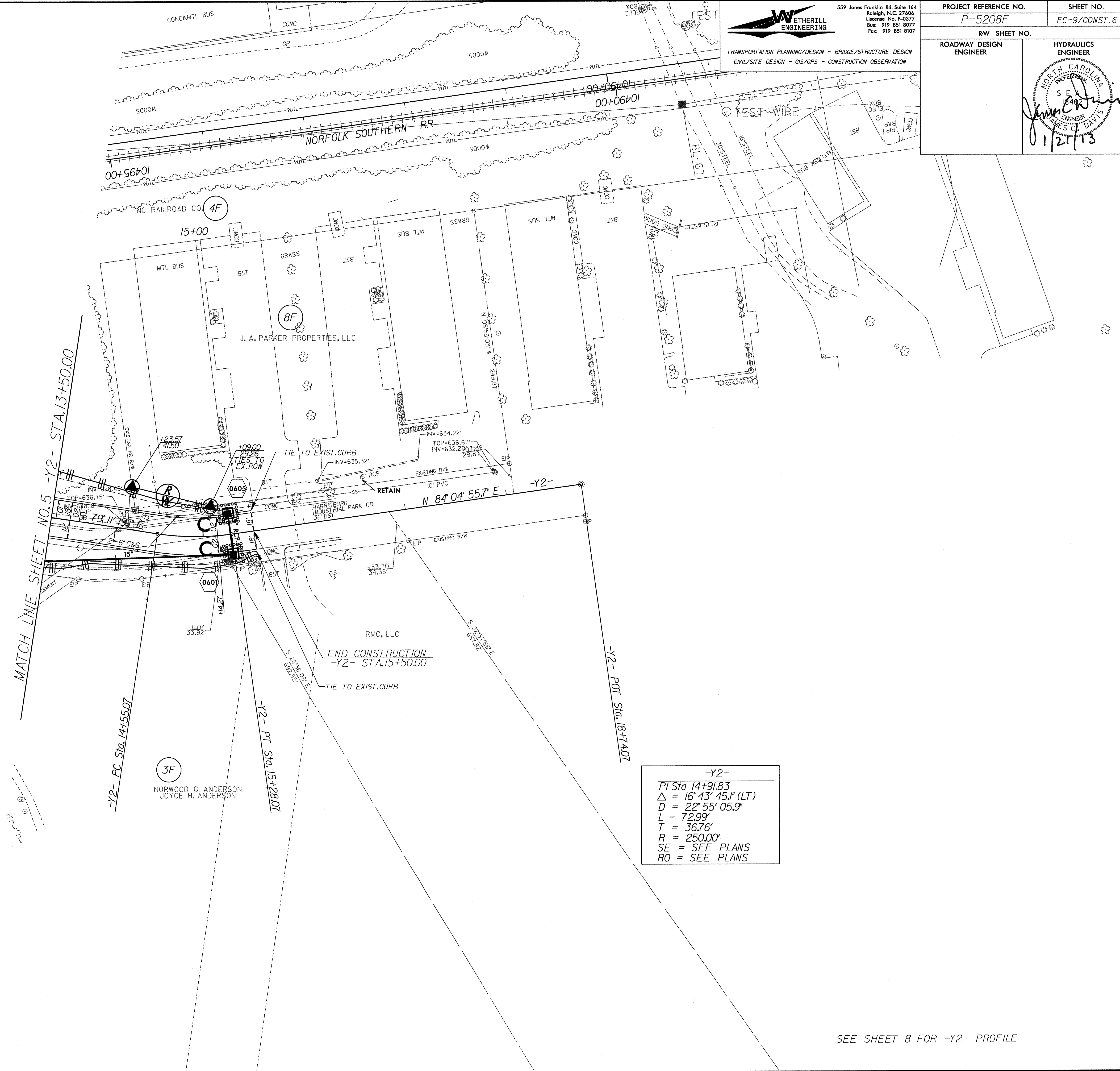

-Y2-  
 PI Sta 14+91.83  
 $\Delta = 16^\circ 43' 45.1''$  (LT)  
 $D = 22^\circ 55' 05.9''$   
 $L = 72.99'$   
 $T = 36.76'$   
 $R = 250.00'$   
 SE = SEE PLANS  
 RO = SEE PLANS

SEE SHEET 8 FOR -Y2- PROFILE

r208\Fr-091907\_Control\EC Plan Sheets\F5208F-ec\_psh\_06.f.mal.dgn 1/21/2013 1:29:55 PM