



PROJECT SPECIAL PROVISIONS

Project 41665.6A

Davidson and Rowan Counties

PAINTING, REPLACING SUPERSTRUCTURE, STEEL MODIFICATION AND REPAIR OF THE SUBSTRUCTURE OF EXISTING STRUCTURE (12-5-12)

DESCRIPTION

This work shall consist of furnishing all labor, equipment, and materials necessary to clean and paint the structural steel of Bridge 65 in Rowan County, Removal of the of the existing superstructure for Bridges number 31, 55 and 82 in Davidson County Work includes: Superstructures removal, removal, containment and disposal of the existing paint system; preparation of the surface to be painted and applying the new paint system; substructure repairs using formed and poured concrete, shotcrete and epoxy injection, asphalt paving approaches, a containment enclosure; traffic control, marking & delineation; portable lighting; erosion and sediment control; seeding and mulching all grassed areas disturbed; and any incidentals necessary to complete the project as specified and shown on the plans. No separate payment will be made for portable lighting as the cost of such is incidental to the work being performed.

CERTIFICATION

The existing paint systems include toxic substances such as red lead oxide, which are considered hazardous if improperly removed. The contractor shall be currently SSPC QP 2, Category A certified, and have successfully completed lead paint removal and field painting on similar structures within 18 months prior to this bid.

The apparent low bidder shall submit a list of projects for which QP 2 work was performed within the last 18 months including owner contact information and submit to the Assistant State Structures Engineer (Operations) a "Lead Abatement Affidavit" by 12:00 noon of the third day following the opening of bids. This form may be downloaded from: <http://www.ncdot.gov/projects/ncbridges/#stats>.

The Engineer will evaluate the work history to verify all lead abatement work was completed in accordance with contract specifications, free of citation from safety or environmental agencies. Lead abatement work shall include, but not be limited to: abrasive blasting; waste handling, storage and disposal; worker safety during lead abatement activities (fall protection, PPE, etc.); and containment. This requirement is in addition to the contractor pre-qualification requirements covered by Article 102-2 of the *2012 Standard Specifications*.

TWELVE-MONTH OBSERVATION PERIOD

The Contractor maintains responsibility for the coating system for a 12 month observation period beginning upon the satisfactory completion of all the work required in the plans or as directed by the Engineer. The Contractor shall guarantee the coating system under the payment and performance bond (refer to Article 109-10 of the *2012 Standard Specifications*). To successfully complete the observation period, the coating system shall meet the following requirements after 12 months service:

- (A) No visible rust, contamination or application defect is observed in any coated area.
- (B) Painted surfaces have a uniform color and gloss.
- (C) Painted surfaces have an adhesion that meets an ASTM D3359, 3A rating.

Final acceptance is made only after the paint system meets the above requirements.

SUBMITTALS

Submit all of the following to the Engineer for review and approval before scheduling the pre-construction meeting. Allow at least 2 weeks for the review process.

- (A) Work schedule which shall be kept up to date, with a copy of the revised schedule being provided to the Engineer in a timely manner,
- (B) Containment Drawings in accordance with SSPC Guide 6, Class 2A sealed by a Professional Engineer licensed by the State of North Carolina,
- (C) Bridge wash water sampling and disposal plan,
- (D) Subcontractor identification,
- (E) Lighting plan for night work in accordance with Section 1413 of the *2012 Standard Specifications*,
- (F) Traffic control plan with NCDOT certified supervisors, flaggers and traffic control devices,
- (G) Health and safety plan addressing at least the required topics as specified by the SSPC QP 1 and QP 2 program and including hazard communication, respiratory health, emergency procedures, and local hospital and treatment facilities with directions and phone numbers, disciplinary criteria for workers who violate the plan and accident investigation. The plan shall address the following: hazardous materials, personal protective equipment, general health and safety, occupational health and environmental controls, fire protection and prevention, signs signals, and barricades, materials handling, storage, use, and disposal, hand and power tools, welding and cutting, electrical, scaffolds, fall protection, cranes, derricks, hoists, elevators, and conveyors, ladders, toxic and hazardous substances, airless injection and HPWJ.
- (H) Provide the Engineer a letter of certification that all employees performing work on the project have blood lead levels that are below the OSHA action level.
- (I) Provide the Engineer with Competent Person qualifications and summary of work experience.
- (J) Environmental Compliance Plan
- (K) Quality Control Plan (Project Specific) with quality control qualifications and summary of work experience.
- (L) Bridge and Public Protection Plan (Overspray, Utilities, etc. - Project/Task Specific)

- (M) Abrasive Blast Media
 - (1) Product Data Sheet
 - (2) Blast Media Test Reports in accordance with Article 1080-13 of the *2012 Standard Specification*.
- (N) Coating Material
 - (1) NCDOT HICAMS Test Reports (testing performed by NCDOT Materials and Tests Unit),
 - (2) Product Data Sheets,
 - (3) Material Safety Data Sheets,
 - (4) Product Specific Repair Procedures, and
 - (5) Acceptance letters from paint manufacturer's for work practices that conflict with Project Special Provisions and/or paint manufactures product data sheets.

PRE-CONSTRUCTION MEETING

Submittals shall be reviewed and approved by the Engineer prior to scheduling the pre-construction meeting. Allow no less than 2 weeks for a review process. When requesting a pre-construction meeting, contact the Engineer at least 7 working days in advance of the desired pre-construction date. The contractor's project supervisor, Competent person, quality control personnel and certified traffic control supervisor shall be in attendance at the pre-construction meeting in order for the Contractor and NCDOT team to establish responsibilities for various personnel during project duration and to establish realistic timeframes for problem escalation.

CONTAINMENT PLAN

No work begins until the Contractor furnishes the Engineer with a containment plan for surface preparation and coating operations and the Engineer reviews and approves, in writing, the acceptability of said plan. Allow a minimum of two weeks for review of the plan. Such plan shall meet or exceed the requirements of Class 2A containment in accordance with SSPC Guide 6. Enclosure drawings and loads supported by the structure shall be prepared, signed and sealed by a Professional Engineer licensed by the State of North Carolina.

In the containment plan describe how debris is contained and collected. Describe the type of tarpaulin, bracing materials and the maximum designed wind load. Describe the dust collection system and how a negative pressure of 0.03 inches of water column is maintained inside the enclosure while blasting operations are being conducted. Describe how the airflow inside the containment structure is designed to meet all applicable OSHA Standards. Describe how water run-off from rain will be routed by or through the enclosure. Describe how wash water will be contained and paint chips separated. Describe what physical containment will be provided during painting application to protect the public and areas not to be painted.

WASH WATER SAMPLING AND DISPOSAL PLAN

No work begins until the Contractor furnishes the Engineer with a containment plan for surface preparation and coating operations and the Engineer reviews and approves in writing said plan. All wash water shall be collected and sampled prior to disposal.

Representative sampling and testing methodology shall conform to 15A NCAC 02B.0103, "Analytical Procedures". Wash water shall be tested for pollutants listed in 15A NCAC 02B.0211(3), 15A NCAC 02T.0505(b)(1) and 15A NCAC 2T.0905(h). Depending on the test results, wash water disposal methods shall be described in the disposal plan. Wash water shall be disposed of in accordance with all current Federal and State regulations. See link for NCDOT Guidelines for Managing Bridge Wash Water: <http://www.ncdot.gov/projects/ncribridges/#stats>.

WASTE HANDLING OF PAINT AND ABRASIVES

Comply with all Federal, State and local regulations. Failure to comply with the regulations could result in fines and loss of qualified status with NCDOT.

Comply with the Resource Conservation and Recovery Act (RCRA - 40 CFR 261 - 265) and the Occupational Safety and Health Act (OSHA - 29 CFR 1910 - 1926) regulations for employee training, and for the handling, storage, labeling, recordkeeping, reporting, inspections and disposal of all hazardous waste generated during paint removal.

A summary of Generator Requirements is available at the above NCDOT web link which cites the specific regulations for each Generator category. Quantities of waste by weight and dates of waste generation shall be recorded. Waste stored at the project site shall be properly labeled. All waste, hazardous or non-hazardous, requires numbered shipping manifests.

The North Carolina Department of Environment and Natural Resources (NCDENR) have adopted RCRA as the North Carolina Hazardous Waste Management Rules and are responsible for enforcement. The "Hazardous Waste Compliance Manual for Generators of Hazardous Waste" is published by the Compliance Branch of the Division of Waste Management of NCDENR, and can be found at: <http://portal.ncdenr.org/web/wm/hw/rules>.

Use a company from the below list of approved waste management companies. Immediately after award of the contract, arrange for waste containers, sampling, testing, transportation and disposal of all waste. No work shall begin until the Contractor furnishes the Engineer with a written waste disposal plan. Any alternative method for handling waste shall be pre-approved by the Engineer.

Southern Logistics, Inc. – 312 Orville Wright Dr., Greensboro, NC 27409
(Ph. 336-662-0292)

A&D Environmental – PO Box 484, High Point, NC 27261
(Ph. 336-434-7750)

Poseidon Environmental Services, Inc. – 837 Boardman-Canfield Rd #209, Youngstown, OH
(Ph. 330-726-1560)

Clean Harbors Reidsville, LLC – 208 Watlington Industrial Drive, Reidsville, NC 27320
(Ph. 336-342-6106)

All removed paint and spent abrasive media shall be tested for lead following the SW-846 TCLP Method 1311 Extraction, as required in 40 CFR 261, Appendix 11, to determine whether it shall be disposed of as hazardous waste. Furnish the Engineer certified test

reports showing TCLP results and Iron analysis of the paint chips stored on site, with disposal in accordance with “Flowchart on Lead Waste Identification and Disposal” at:

http://portal.ncdenr.org/c/document_library/get_file?p_l_id=38491&folderId=328599&name=DLFE-9855.pdf.

All sampling shall be done in presence of the Engineer’s representative.

The Competent Person shall obtain composite samples from each barrel of the wash water and waste generated by collecting two or more portions taken at regularly spaced intervals during accumulation. Composite the portions into one sample for testing purposes. Acquire samples after 10% or before 90% of the barrel has accumulated. The intent is to provide samples that are representative of widely separated portions, but not the beginning and end of wash water or waste accumulation.

Perform sampling by passing a receptacle completely through the discharge stream or by completely diverting the discharge into a sample container. If discharge of the wash water or waste is too rapid to divert the complete discharge stream, discharge into a container or transportation unit sufficiently large to accommodate the flow and then accomplish the sampling in the same manner as described above.

Comply with the NCDENR Hazardous Waste Compliance Manual for Generators of Hazardous Waste. Record quantities of waste by weight and dates of waste generation. Until test results are received, store all waste, and label as “NCDOT Bridge Paint Removal Waste - Pending Analysis” and include the date generated and contact information for the Division HazMat Manager or Project Engineer. Store waste containers in an enclosed, sealed and secured storage container protected from traffic from all directions. Obtain approval for the protection plan for these containers from the Engineer. If adequate protection cannot be obtained by use of existing guardrail, provide the necessary supplies and equipment to maintain adequate protection. Once test results are received and characterized, label waste as either “Hazardous Waste - Pending Disposal” or “Paint Waste - Pending Disposal”.

Once the waste has been collected, and the quantities determined, prepare the appropriate shipping documents and manifests and present them to the Engineer. The Engineer will verify the type and quantity of waste and obtain a Provisional EPA ID number from the:

NC Hazardous Waste Section
North Carolina Department of Environment & Natural Resources
1646 Mail Service Center
Raleigh, NC 27699
Phone (919) 508-8400, Fax (919) 715-4061

At the time of shipping, the Engineer will sign, date and add the ID number in the appropriate section on the manifest. The maximum on-site storage time for collected waste shall be 90 days. All waste whether hazardous or non-hazardous will require numbered shipping manifests. The cost for waste disposal (including lab and Provisional EPA ID number) is included in the bid price for this contract. Note NC Hazardous Waste

Management Rules (15A NCAC 13A) for more information. Provisional EPA ID numbers may be obtained at this link:

<http://portal.ncdenr.org/web/wm/provisional-hw-notification-page>.

Testing labs shall be certified in accordance with North Carolina State Laboratory Public Health Environmental Sciences. List of certified laboratories may be obtained at this link:

<http://slphreporting.ncpublichealth.com/EnvironmentalSciences/Certification/CertifiedLaboratory.asp>.

All test results shall be documented on the lab analysis as follows:

1. For leachable lead:
 - a. Soils/Solid/Liquid- EPA 1311/200.7/6010

Area sampling will be performed for the first 2 days at each bridge location. The area sample will be located within five feet of the containment and where the highest probability of leakage will occur (access door, etc.). Results from the area sampling will be given to the Engineer within 72 hours of sampling (excluding weekends). If the results of the samples exceed $20 \mu\text{g}/\text{m}^3$ corrective measures shall be taken and monitoring shall be continued until 2 consecutive sample results are less than $20 \mu\text{g}/\text{m}^3$.

TWA may suspend the work if there are visible emissions outside the containment enclosure or pump monitoring results exceeding the level of $30 \mu\text{g}/\text{m}^3$.

Where schools, housing and/or buildings are within 500 feet of the containment, the Contractor shall perform initial TSP-Lead monitoring for the first 10 days of the project during abrasive blasting, vacuuming and containment removal. Additional monitoring will be required during abrasive blasting 2 days per month thereafter. Results of the TSP monitoring at any location shall not exceed $1.5 \mu\text{g}/\text{m}^3$.

EQUIPMENT MOBILIZATION

The equipment used in any travel lanes and paved shoulder shall be mobile equipment on wheels that has the ability to move on/off the roadway in less than 30 minutes. All work conducted in travel lanes shall be from truck or trailer supported platforms and all equipment shall be self-propelled or attached to a tow vehicle at all times.

QUALITY CONTROL INSPECTOR

Provide a quality control inspector in accordance with the SSPC QP guidelines to ensure that all processes, preparation, blasting and coating application are in accordance with the requirements of the contract. The inspector shall have written authority to perform QC duties to include continuous improvement of all QC internal procedures. The presence of the Engineer or inspector at the work site shall in no way lessen the contractor's responsibility for conformity with the contract.

QUALITY ASSURANCE INSPECTOR

The quality assurance inspector which may be a Department employee or a designated representative of the Department shall observe, document, assess and report that the Contractor is complying with all of the requirements of the contract. Inspectors employed by the Department are authorized to inspect all work performed and materials furnished. Such inspection may extend to all or any part of the work and to the preparation, fabrication or manufacture of the materials to be used. The inspector is not authorized to alter or waive the requirements of the contract. Each stage in preparing the structure to be coated which includes but not limited to washing, blasting, coating testing and inspection shall be inspected and approved by the Engineer or his authorized representative.

SUBLETTING OF CONTRACT

Only contractors certified to meet SSPC QP 2, Category A, and have successfully completed lead paint removal and field painting on all similar structures within 18 months prior to this bid are qualified for this work. Work is only sublet by approval of the Engineer.

PREPARATION OF SURFACES

Before any other surface preparation is conducted, all surfaces shall be power washed to remove dust, salts, dirt and other contaminants. All wash water shall be contained, collected and tested in accordance with the requirements of NCDOT Managing Bridge Wash Water specification. Obtain approval of the Engineer and allow all cleaned surfaces to dry to the touch and without standing water before beginning surface preparation or painting activities.

Surface preparation is done with materials meeting Article 1080-13 of the *2012 Standard Specifications*. No silica sand or other silica materials are permitted for use. The profile shall be between 1.0 and 3.0 mils when measured on a smooth steel surface. Conduct and document at least 2 tests per beam/girder and 2 tests per span of diaphragms/cross bracing.

Spread tarpaulins over all pavements and surfaces underneath equipment used for abrasive blasting as well as equipment and containers used to collect abrasive media. This requirement will be enforced during activity and inactivity of equipment.

Before the Contractor departs from the work site at the end of the work day, collect all debris generated during surface preparation and all dust collector hoses, tarps or other appurtenances containing blasting residue in approved containers.

Clean a 3" x 3" area at each structure to demonstrate the specified finish, and the inspector will preserve this area by covering it with tape, plastic or some other suitable means so that it can be retained as the Dry Film Thickness (DFT) gauge adjustment standard. An acceptable alternative is for the Contractor to provide a steel plate with similar properties and geometry as the substrate to be measured.

The contractor and or quality assurance representative shall notify the Engineer of any area of corroded steel which has lost more than 50% of its original thickness.

All parts of the bridges not to be painted and the travelling public shall be protected from overspray. Submit a plan to protect all parts of bridge that are not required to be painted and a plan to protect the traveling public and surrounding environment while applying all coats of paint to a structure.

Ensure that chloride levels on the surfaces are $7 \mu\text{g}/\text{cm}^2$ or lower using an acceptable sample method in accordance with SSPC Guide 15. The frequency of testing shall be 2 tests per span after all surface preparation has been completed and immediately prior to painting. Select test areas representing the greatest amount of corrosion in the span as determined by the Engineers' representative. Additional testing may be required if significant amounts of chloride are detected.

All weld splatter, slag or other surface defects resulting in a raised surface above the final paint layer shall be removed prior to application of primer coat.

PAINTING OF STEEL

Paint System 1, as specified in these special provisions and Section 442 of the *2012 Standard Specifications*, is to be used for this work. System 1 is an inorganic zinc primer, two coats acrylic paint and one stripe coat of acrylic paint over blast cleaned surfaces in accordance with SSPC-SP-10 (Near White Blast). Perform all mixing operations over an impervious surface with provisions to prevent runoff to grade of any spilled material. The contractor is responsible for reporting quantities of thinner purchased as well the amounts used. No container with thinner shall be left uncovered, when not in use.

Apply 2" stripe coat, by brush or roller only, to all exposed edges of steel including fasteners before applying the finish coat. Locate the edge or corner in the approximate center of the paint stripe.

Any area where newly applied paint fails to meet the specifications shall be repaired or replaced by the Contractor. The Engineer approves all repair processes before the repair is made. Repaired areas shall meet the specifications. The Contractor applies an additional finish coat of paint to areas where the tape adhesion test is conducted.

MATERIALS

Only paint suppliers that have a NCDOT qualified inorganic zinc primer may furnish paints for this project. All paints applied to a structure shall be from the same supplier. Before any paints are applied the Contractor shall provide the Engineer a manufacturer's certification that each batch of paint meets the requirements of the applicable Section 1080 of the *2012 Standard Specifications*.

The inspector randomly collects a one pint sample of each paint product used on the project. Additional samples may be collected as needed to verify compliance to the specifications.

Do not expose paint materials to rain, excessive condensation, long periods of direct sunlight, or temperatures above 110°F or below 40°F . In addition, the Contractor shall place a device which records the high, low and current temperatures inside the storage

location. Follow the manufacturer's storage requirements if more restrictive than the above requirements.

INSPECTION

Surface Preparation for System 1 shall be in accordance with SSPC SP-10. Any area(s) not meeting the requirements of SSPC SP-10 shall be remediated prior to application of coating. Surface inspection is considered ready for inspection when all blast abrasive, residue and dust is removed from surfaces to be coated.

(A) Quality Assurance Inspection

The Contractor furnishes all necessary OSHA approved apparatus such as ladders, scaffolds and platforms as required for the inspector to have reasonable and safe access to all parts of the work. The contractor illuminates the surfaces to be inspected to a minimum of 50-foot candles of light. All access points shall be illuminated to a minimum of 20-foot candles of light.

NCDOT reserves the right for ongoing QA (Quality Assurance) inspection to include but not limited to surface contamination testing, adhesion pull testing and DFT readings as necessary to assure quality.

Inform the Engineer and the Division Safety Engineer of all scheduled and unannounced inspections from SSPC, OSHA, EPA and/or others that come on site. Furnish the Engineer a copy of all inspection reports except for reports performed by a third party and or consultant on behalf of the Contractor.

(B) Inspection Instruments

At a minimum, furnish the following calibrated instruments and conduct the following quality control tests:

- (1) Sling Psychrometer - ASTM E337 - bulb type
- (2) Surface Temperature Thermometer
- (3) Wind Speed Indicator
- (4) Tape Profile Tester - ASTM D4417 Method C
- (5) Surface Condition Standards - SSPC VIS-1 and VIS-3
- (6) Wet Film Thickness Gage - ASTM D4414
- (7) Dry Film Thickness Gage - SSPC-PA2 Modified
- (8) Solvent Rub Test Kit - ASTM D4752
- (9) Adhesion Test Kit - ASTM D3359 Method A (Tape Test)
- (10) Adhesion Pull test - ASTM D4541
- (11) Surface Contamination Analysis Kit or (Chloride Level Test Kit)
SSPC Technology Guide 15

(C) Quality Control

Maintain a daily quality control record in accordance with Article 442-13 of the *2012 Standard Specifications* and make such records available at the job site for review by the inspector and submit to the Engineer as directed. In addition to the

information required on M&T-610, submit all Dry Film Thickness (DFT) readings on a form equivalent to M&T-611.

- (1) Measure DFT at each spot on the attached diagram and at the required number of locations as specified below:
 - (a) For span members less than 45 feet; three random locations along each girder in each span.
 - (b) For span members greater than 45 feet; add one additional location for each additional 10 feet in span length.

DFT measurements for the prime coat shall not be taken for record until the zinc primer has cured in accordance with ASTM D4752 (MEK Rub Test) with no less than a four resistance rating.

Stiffeners and other attachments to beams and or plate girders shall be measured at no less than five random spots per span. Also dry film thickness is measured at no less than six random spots per span on diaphragms/"K" frames.

Each spot is an average of three to five individual gage readings as defined in SSPC PA-2. No spot average shall be less than 80% of minimum DFT for each layer applied; this does not apply to stripe coat application. Spot readings that are non-conforming shall be re-accessed by performing additional spot measurements not to exceed one foot intervals on both sides of the low areas until acceptable spot averages are obtained. These non-conforming areas shall be corrected by the Contractor prior to applying successive coats.

**Less than 36" in height and/or bottom flanges
less than 16" in width.**

**7 Spot Areas
21 Individual DFT Readings**

**7 Spot Areas
21 Individual DFT Readings**

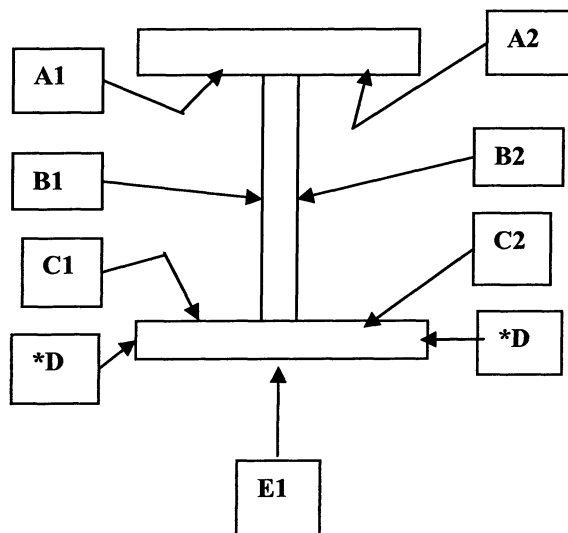

***D areas are only included when flange
thickness is one inch (1") or greater.**

**36" in height or greater and/or bottom
flanges greater than 16" in width.**

**10 Spot Areas
30 Individual DFT Readings**

**7 Spot Areas
21 Individual DFT Readings**

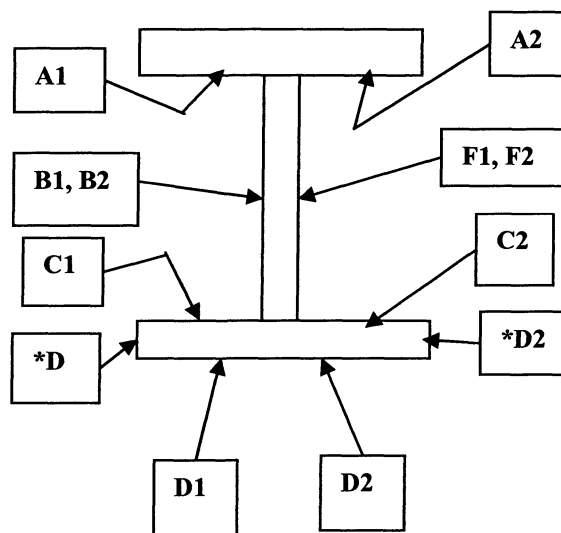

***D areas are only included when flange
thickness is one inch (1") or greater.**

- (2) Two random adhesion tests (1 test=3 dollies) per span are conducted on interior surfaces in accordance with ASTM D4541 (Adhesion Pull Test) after the prime coat has been properly cured in accordance with ASTM D4752 (MEK Rub Test) with no less than a 4 resistance rating, and will be touched up by the Contractor. The required minimum average adhesion is 400 psi.
- (3) Cure of the intermediate and stripe coats shall be accessed by using the thumb test in accordance with ASTM D1640 (Curing Formation Test) prior to the application of any successive layers of paint.
- (4) One random Cut Tape adhesion test per span is conducted in accordance with ASTM D3359 (X-Cut Tape Test) on interior surface after the finish coat is cured. Repair areas shall be properly tapered and touched up by the Contractor.

SAFETY AND ENVIRONMENTAL COMPLIANCE PLANS

Personnel access boundaries are delineated for each work site using signs, tape, cones or other approved means. Submit copies of safety and environmental compliance plans that comply with SSPC QP 2 Certification requirements.

HEALTH AND SAFETY RESPONSIBILITIES

This project may involve toxic metals such as arsenic, lead, cadmium and hexavalent chromium. It is the contractor's responsibility to test for toxic metals and if found, comply with the OSHA regulations, which may include medical testing.

Ensure a "Competent Person" as defined in OSHA 29 CFR 1926.62; one who is capable of identifying existing and predictable hazards in the surroundings or working conditions which are unsanitary, hazardous, or dangerous to employees, and who has authorization to take prompt corrective measures to eliminate them; is on site during all surface preparation activities and monitors the effectiveness of containment, dust collection systems and waste sampling. Before any work begins, provide a written summary of the Competent Person's safety training.

Comply with Subarticle 442-14(B) of the *2012 Standard Specifications*.

Comply with Subarticle 442-14(D) of the *2012 Standard Specifications*. Ensure employee blood sampling test results are less than 50 micrograms per deciliter. Remove employees with a blood sampling test of 50 or more micrograms per deciliter from work activities involving any lead exposure.

An employee who has been removed with a blood level of 50 micrograms per deciliter or more shall have two consecutive blood sampling tests spaced one week apart indicating that the employee's blood lead level is at or below 40 micrograms per deciliter before returning to work activities involving any lead exposure.

All OSHA recordable accidents that occur during the project duration are to be reported to the Engineer within twenty-four (24) hours of occurrence. In addition, for accidents that involve civilians or property damage that occurs within the work zone the Division Safety Engineer shall be notified immediately.

Prior to blasting operations, the Contractor shall have an operational OSHA approved hand wash station at each bridge location and a decontamination trailer at each bridge or between bridges unless the work is on the roadway, or the Contractor shall show reason why it is not feasible to do so and provide an alternative site as approved by the Engineer. The Contractor shall assure that all employees whose airborne exposure to lead is above the PEL shall shower at the end of their work shift.

STORAGE OF PAINT AND EQUIPMENT

Provide a location for materials, equipment and waste storage. Spread tarpaulins over all pavements and surfaces underneath equipment used for abrasive recycling and other waste handling equipment or containers. All land and or lease agreements that involve private property shall disclose to the property owner that heavy metals may be present on the

Contractor's equipment. Prior to storing the Contractor's equipment on private property, provide a notarized written consent signed by the land owner received by the Engineer at least forty-eight (48) hours before using property. All storage of paint, solvents and other materials applied to structures shall be stored in accordance with Section 442 of the *2012 Standard Specifications* or the manufacturers' requirements. The more restrictive requirements will apply.

UTILITIES

Protect all utility lines or mains which may be supported on, under, or adjacent to bridge work sites from damage and paint overspray.

MEASUREMENT AND PAYMENT

The cost of inspection, surface preparation and repainting the existing structure is included in the lump sum price bid for *Cleaning and Repainting of Bridge #___*. This price is full compensation for furnishing all inspection equipment, all paint, cleaning abrasives, cleaning solvents and all other materials; preparing and cleaning surfaces to be painted; applying paint in the field; protecting work area, traffic and property; and furnishing blast cleaning equipment, paint spraying equipment, brushes, rollers, any other hand or power tools and any other equipment; and a containment enclosure.

Pollution Control will be paid at the contract lump sum price which will be full compensation for all collection, handling, storage, air monitoring, and disposal of debris and wash water, all personal protective equipment, and all personal hygiene requirements, and all equipment, material and labor necessary for the daily collection of the blast debris into specified containers; and any measures necessary to ensure conformance to all safety and environmental regulations as directed by the Engineer.

Payment will be made under:

Pay Item	Pay Unit
Cleaning and Repainting of Bridge #65	Lump Sum
Pollution Control	Lump Sum

CLEANING AND PAINTING EXISTING BEARING PLATES

(12-5-12)

Thoroughly clean the exposed surfaces of all bearing plates, anchor bolts, nuts and washers on the existing structure in accordance with the Article 442-7(B) of the Standard Specifications. The Engineer shall approve the cleaning of each unit before painting.

After cleaning, apply a touch up coat of natural color organic zinc repair paint to the steel followed by a complete coat of the same paint.

Payment at the contract unit prices for the various pay items will be full compensation for the above work required for cleaning and painting existing bearing plates.

DESCRIPTION OF BRIDGE

Rowan #65: The existing bridge was built in 1967 and carries SR1221 (Old Beatty Ford Road) over I-85. The superstructure consists of 5 lines of steel girders with steel channel diaphragms at a spacing of 7'-6". Girders in spans A and D are W36x135 for exterior girders and W24x76 for interior girders. Girders in spans B and C are W36x150 for exterior girders and W36x135 for interior girders. The bridge is approximately 249' in length with a concrete deck that is 36' wide, out to out. The existing paint system is aluminum oxide over red lead, and the estimated area to be cleaned and painted is 12,500 square feet.

PARTIAL REMOVAL OF EXISTING STRUCTURE AT BRIDGE NO. 31 SPECIAL

1.0 DESCRIPTION

Remove concrete bridge rail, end posts, concrete deck slab, steel diaphragms, steel girders and bearing assemblies in accordance with Section 402 of the Standard Specifications for Roads and Structures. Partial removal of existing structure shall be performed so as not to allow debris to fall below the bridge.

2.0 MEASUREMENT AND PAYMENT

Partial Removal of Existing Structure at Bridge #31 will be paid for at the contract lump sum price.

Payment will be made under:

Pay Item	Pay Unit
Partial Removal of Existing Structure at Bridge #31	Lump Sum

PARTIAL REMOVAL OF EXISTING STRUCTURE AT BRIDGE NO. 55 SPECIAL

1.0 DESCRIPTION

Remove concrete bridge rail, end posts, concrete deck slab, steel diaphragms, steel girders and bearing assemblies in accordance with Section 402 of the Standard Specifications for Roads and Structures. Partial removal of existing structure shall be performed so as not to allow debris to fall below the bridge.

2.0 MEASUREMENT AND PAYMENT

Partial Removal of Existing Structure at Bridge #55 will be paid for at the contract lump sum price.

Payment will be made under:

Pay Item	Pay Unit
Partial Removal of Existing Structure at Bridge #55	Lump Sum

PARTIAL REMOVAL OF EXISTING STRUCTURE AT BRIDGE NO. 82 SPECIAL**1.0 DESCRIPTION**

Remove concrete bridge rail, end posts, concrete deck slab, steel diaphragms, steel girders and bearing assemblies in accordance with Section 402 of the Standard Specifications for Roads and Structures. Partial removal of existing structure shall be performed so as not to allow debris to fall below the bridge.

2.0 MEASUREMENT AND PAYMENT

Partial Removal of Existing Structure at Bridge #82 will be paid for at the contract lump sum price.

Payment will be made under:

Pay Item	Pay Unit
Partial Removal of Existing Structure at Bridge #82	Lump Sum

PARTIAL REMOVAL OF EXISTING STRUCTURE AT BRIDGE NO. 65 SPECIAL**1.0 DESCRIPTION**

Remove metal rail, concrete parapet, end posts, concrete deck slab, concrete diaphragms, concrete curtain walls and bearing assemblies in accordance with Section 402 of the Standard Specifications for Roads and Structures. Steel girders, shear connectors, and steel diaphragms shall remain in place. The contractor shall take precautions to protect from damage, scoring or marring the steel components that are to remain in the structure. Any damage to the structure either existing or incurred during to the removal procedure shall be brought to the attention of the Engineer and repaired to the satisfaction of the Engineer. Partial removal of existing structure shall be performed so as not to allow debris to fall below the bridge.

2.0 MEASUREMENT AND PAYMENT

Partial Removal of Existing Structure at Bridge #65 will be paid for at the contract lump sum price.

Payment will be made under:

Pay Item	Pay Unit
Partial Removal of Existing Structure at Bridge #65	Lump Sum

UNCLASSIFIED STRUCTURE EXCAVATION:

SPECIAL

1.0 DESCRIPTION

Unclassified structure excavation shall be performed in accordance with Section 412 of the Standard Specifications for Roads and Structures.

2.0 MEASUREMENT AND PAYMENT

Unclassified Structure Excavation at Bridge #___ will be paid for at the contract lump sum price.

Payment will be made under:

Pay Item	Pay Unit
Unclassified Structure Excavation at Bridge #___	Lump Sum

**MAINTENANCE AND PROTECTION OF TRAFFIC
BENEATH PROPOSED STRUCTURE (Bridge #65)**

(8-13-04)

1.0 GENERAL

Maintain traffic on Bridge #65 for Rowan County as shown in Traffic Control Plans and as directed by the Engineer.

Provide a minimum temporary vertical clearance of 16'-11" at all times during construction.

Submit plans and calculations for review and approval for protecting traffic and bracing girders, as described herein, at the above station before beginning work at this location. Have the drawings and design calculations prepared, signed, and sealed by a North Carolina Registered Professional Engineer. The approval of the Engineer will not relieve the Contractor of the responsibility for the safety of the method or equipment.

2.0 PROTECTION OF TRAFFIC

Protect traffic from any operation that affords the opportunity for construction materials, equipment, tools, etc. to be dropped into the path of traffic beneath the structure. Based on Contractor means and methods determine and clearly define all dead and live loads for this system, which, at a minimum, shall be installed between beams or girders over any travelway or shoulder area where traffic is maintained. Install the protective system before beginning any construction operations over traffic. In addition, for these same areas, keep the overhang falsework in place until after the rails have been poured.

3.0 BRACING GIRDERS

Brace girders to resist wind forces, weight of forms and other temporary loads, especially those eccentric to the vertical axis of the member during all stages of erection and construction. Before casting of intermediate diaphragms, decks, or connecting steel diaphragms do not allow the horizontal movement of girders to exceed 1/2 inch.

4.0 BASIS OF PAYMENT

Payment at the contract unit prices for the various pay items will be full compensation for the above work.

EPOXY RESIN INJECTION

(12-5-12)

1.0 GENERAL

For repairing cracks, an approved applicator is required to perform the epoxy resin injection. Make certain the supervisor and the workmen have completed an instruction program in the methods of restoring concrete structures utilizing the epoxy injection process and have a record of satisfactory performance on similar projects.

The applicator furnishes all materials, tools, equipment, appliances, labor and supervision required when repairing cracks with the injection of an epoxy resin adhesive.

2.0 SCOPE OF WORK

Using Epoxy Resin Injection, repair all cracks 10 mils (250 μm) wide or greater in the interior bent columns, caps, beam seats; in the ends bents; deck underside. Repair the column cracks to the top of the footings. Make the underwater repairs when water surface elevation is low and the water is still. For underwater repairs, use manufacturer recommended materials.

Repair any crack, void, honeycomb or spall area unsuitable for repair by injection with epoxy mortar.

3.0 COOPERATION

Cooperate and coordinate with the Technical Representative of the epoxy resin manufacturer for satisfactory performance of the work.

Have the Technical Representative present when the job begins and until the Engineer is assured that his service is no longer needed.

The expense of having this representative on the job is the Contractor's responsibility and no direct payment will be made for this expense.

4.0 TESTING

The North Carolina Department of Transportation Materials and Tests Unit will obtain cores from the repaired concrete for testing. If the failure plane is located at the repaired crack, a minimum compressive strength of 3000 psi is required of these cores.

5.0 MATERIAL PROPERTIES

Provide a two-component structural epoxy adhesive for injection into cracks or other voids. Provide modified epoxy resin (Component "A") that conforms to the following requirements:

	Test Method	Specification Requirements
Viscosity @ 40 ± 3°F, cps	Brookfield RVT Spindle No. 4 @ 20 rpm	6000 - 8000
Viscosity @ 77 ± 3°F, cps	Brookfield RVT Spindle No. 2 @ 20 rpm	400 - 700
Epoxide Equivalent Weight	ASTM D1652	152 - 168
Ash Content, %	ASTM D482	1 max.

Provide the amine curing agent (Component "B") used with the epoxy resin that meets the following requirements:

	Test Method	Specification Requirements
Viscosity @ 40 ± 3°F, cps	Brookfield RVT Spindle No. 2 @ 20 rpm	700 - 1400
Viscosity @ 77 ± 3°F, cps	Brookfield RVT Spindle No. 2 @ 20 rpm	105 - 240
Amine Value, mg KOH/g	ASTM D664*	490 - 560
Ash Content, %	ASTM D482	1 max.
* Method modified to use perchloric acid in acetic acid.		

Certify that the Uncured Adhesive, when mixed in the mix ratio that the material supplier specifies, has the following properties:

Pot Life (60 gram mass)

@ 77 ± 3°F - 15 minutes minimum

@ 100 ± 3°F - 5 minutes minimum

Certify that the Adhesive, when cured for 7 days at $77 \pm 3^\circ\text{F}$ unless otherwise specified, has the following properties:

	Test Method	Specification Requirements
Ultimate Tensile Strength	ASTM D638	7000 psi (min.)
Tensile Elongation at Break	ASTM D638	4% max.
Flexural Strength	ASTM D790	10,000 psi (min.)
Flexural Modulus	ASTM D790	3.5×10^5 psi
Compressive Yield Strength	ASTM D695	11,000 psi (min.)
Compressive Modulus	ASTM D695	$2.0 - 3.5 \times 10^5$ psi
Heat Deflection Temperature Cured 28 days @ $77 \pm 3^\circ\text{F}$	ASTM D648*	125°F min. 135°F min.
Slant Shear Strength, 5000 psi (34.5 MPa) compressive strength concrete Cured 3 days @ 40°F wet concrete Cured 7 days @ 40°F wet concrete Cured 1 day @ 77°F dry concrete	AASHTO T237	3500 psi (min.) 4000 psi (min.) 5000 psi (min.)
* Cure test specimens so that the peak exothermic temperature of the adhesive does not exceed 77°F .		

Use an epoxy bonding agent, as specified for epoxy mortar, as the surface seal (used to confine the epoxy resin during injection).

6.0 EQUIPMENT FOR INJECTION

Use portable positive displacement type pumps with interlock to provide positive ratio control of exact proportions of the two components at the nozzle to meter and mix the two injection adhesive components and inject the mixed adhesive into the crack. Use electric or air powered pumps that provide in-line metering and mixing.

Use injection equipment with automatic pressure control capable of discharging the mixed adhesive at any pre-set pressure up to 200 ± 5 psi and equipped with a manual pressure control override.

Use equipment capable of maintaining the volume ratio for the injection adhesive as prescribed by the manufacturer. A tolerance of $\pm 5\%$ by volume at any discharge pressure up to 200 psi is permitted.

Provide injection equipment with sensors on both the Component A and B reservoirs that automatically stop the machine when only one component is being pumped to the mixing head.

7.0 PREPARATION

Follow these steps prior to injecting the epoxy resin:

- Remove all dirt, dust, grease, oil, efflorescence and other foreign matter detrimental to the bond of the epoxy injection surface seal system from the surfaces adjacent to the cracks or other areas of application. Acids and corrosives are not permitted.
- Provide entry ports along the crack at intervals not less than the thickness of the concrete at that location.
- Apply surface seal material to the face of the crack between the entry ports. For through cracks, apply surface seal to both faces.
- Allow enough time for the surface seal material to gain adequate strength before proceeding with the injection.

8.0 EPOXY INJECTION

Begin epoxy adhesive injection in vertical cracks at the lower entry port and continue until the epoxy adhesive appears at the next higher entry port adjacent to the entry port being pumped.

Begin epoxy adhesive injection in horizontal cracks at one end of the crack and continue as long as the injection equipment meter indicates adhesive is being dispensed or until adhesive shows at the next entry port.

When epoxy adhesive appears at the next adjacent port, stop the current injection and transfer the epoxy injection to the next adjacent port where epoxy adhesive appeared.

Perform epoxy adhesive injection continuously until cracks are completely filled.

If port to port travel of epoxy adhesive is not indicated, immediately stop the work and notify the Engineer.

9.0 FINISHING

When cracks are completely filled, allow the epoxy adhesive to cure for sufficient time to allow the removal of the surface seal without any draining or runback of epoxy material from the cracks.

Remove the surface seal material and injection adhesive runs or spills from concrete surfaces.

Finish the face of the crack flush to the adjacent concrete, removing any indentations or protrusions caused by the placement of entry ports.

10.0 BASIS OF PAYMENT

Payment for epoxy resin injection will be at the contract unit price per linear foot for "Epoxy Resin Injection". Such payment will be full compensation for all materials, tools, equipment, labor, and for all incidentals necessary to complete the work.

CONCRETE REPAIRS

(12-5-12)

DESCRIPTION

Work includes removal of concrete in spalled, delaminated and/or cracked areas of the existing caps and columns in reasonably close conformity with the lines, depth, and details shown on the plans, described herein and as established by the Engineer. This work also includes straightening, cleaning, and replacement of reinforcing steel, doweling new reinforcing steel, removing all loose materials, removing and disposing of debris, formwork, applying repair material, and protecting adjacent areas of the bridge and environment from material leakage. The repair material shall be one of the below described materials unless otherwise noted in the plans or provisions.

The location and extent of repairs shown on the plans described herein are general in nature. The Engineer determines the extent of removal in the field based on an evaluation of the condition of the exposed surfaces. The Contractor shall coordinate removal operations with the Engineer. No more than 30% of a round or square column or 30% of the bearing area under a beam shall be removed without a temporary support system and approval from the Engineer.

Repair, to the Engineer's satisfaction, any portion of the structure that is damaged from construction operations. No extra payment is provided for these repairs.

REPAIR MATERIAL OPTIONS**Polymer Modified Concrete Repair Material**

Repair material shall be polymer modified cement mortar for vertical or overhead applications and shall be suitable for applications in marine environments. Material shall be approved for use by NCDOT. Submit repair material to the Engineer for review and approval prior to beginning the work. Color of repair material shall be concrete gray.

Prior to the application of repair mortar, square up edges in repair areas, thoroughly clean surfaces to be repaired and remove all loose materials. Remove grease, wax, salt, and oil contaminants by scrubbing with an industrial grade detergent or degreasing compound followed by a mechanical cleaning. Remove weak or deteriorated concrete to sound concrete by bush hammering, gritblasting, scarifying, waterblasting, or other approved methods. Remove dirt, dust, laitance and curing compounds by gritblasting, sanding, or etching with 15% hydrochloric acid. Acid etch only if approved by the Engineer. Follow acid etching by scrubbing and flushing with copious amounts of clean water. Check the cleaning using moist pH paper. Water cleaning is complete when the paper reads 10 or higher.

Follow all mechanical cleaning with vacuum cleaning.

When surface preparation is completed, mix and apply repair mortar in accordance with manufacturer's recommendations. Use aggregate that is washed, kiln-dried, and bagged. Apply bonding agent to all repair areas immediately prior to placing repair mortar. Repair areas shall be formed unless otherwise approved by the Engineer. Form areas to establish the original neat lines of the member being repaired.

Apply repair mortar to damp surfaces only when approved. In such instances, remove all free water by air-blasting. After applying the repair mortar, remove excessive material and provide a smooth, flush surface.

Class A Concrete Repair Material

Repair material shall be Class A Portland Cement Concrete as described in Section 1000 of the Standard Specifications.

Prior to the application of Class A concrete, square up edges in repair areas, thoroughly clean surfaces to be repaired and remove all loose materials. Remove grease, wax, salt, and oil contaminants by scrubbing with an industrial grade detergent or degreasing compound followed by a mechanical cleaning. Remove weak or deteriorated concrete to sound concrete by bush hammering, gritblasting, scarifying, waterblasting, or other approved methods. Remove dirt, dust, laitance and curing compounds by gritblasting, sanding, or etching with 15% hydrochloric acid. Acid etch only if approved by the Engineer. Follow acid etching by scrubbing and flushing with copious amounts of clean water. Check the cleaning using moist pH paper. Water cleaning is complete when the paper reads 10 or higher.

Follow all mechanical cleaning with vacuum cleaning.

Upon completion of surface preparation, mix and apply concrete in accordance with Standard Specifications and/or manufacturer's recommendations. Use aggregate that is washed, kiln-dried, and bagged. Apply bonding agent to all repair areas immediately prior to placing repair mortar. Repair areas shall be formed unless otherwise approved by the Engineer. Form areas to establish the original neat lines of the member being repaired.

Apply concrete to damp surfaces only when approved. In such instances, remove all free water by air-blasting. After applying the repair mortar, remove excessive material and provide a smooth, flush surface.

TEMPORARY WORK PLATFORM

Prior to beginning any repair work, provide details for a sufficiently sized temporary work platform at each repair location. Design steel members to meet the requirements of the American Institute of Steel Construction Manual. Design timber members in accordance with the "National Design Specification for Stress-Grade Lumber and Its Fastenings" of the National Forest Products Association. Submit the platform design and plans for review and approval. The design and plans shall be sealed and signed by a North Carolina registered Professional Engineer. Do not install the platform until the design and plans are approved. Drilling holes in the superstructure for the purpose of attaching the platform is prohibited. Upon completion of work, remove all anchorages in the substructure and repair the substructure at no additional cost to the Department.

MEASUREMENT AND PAYMENT

Concrete Repairs will be measured and paid for at the contract unit price bid per cubic foot and will be full compensation for removal, containment and disposal off-site of unsound concrete including the cost of materials, reinforcing steel, labor, tools, equipment and

incidentals necessary to complete the repair work. Depth will be measured from the original outside concrete face. The Contractor and Engineer will measure quantities after removal of unsound concrete and before application of repair material. Payment will also include the cost of sandblasting, surface cleaning and preparation, cleaning of reinforcing steel, placement of new reinforcing steel, cost of temporary work platform, testing of the soundness of the exposed concrete surface, furnishing and installation of repair mortar material, curing and sampling of concrete, and protection/cleaning of adjacent areas from splatter or leakage.

Reinforcing Steel that is required for the repairs will be in accordance with Section 425 of the Standard Specifications.

Payment will be made under:

Pay Item	Pay Unit
Concrete Repairs	Cubic Feet

ELASTOMERIC CONCRETE

(12-18-12)

1.0 DESCRIPTION

Elastomeric concrete is a mixture of a two-part polymer consisting of polyurethane and/or epoxy and kiln-dried aggregate. Provide an elastomeric concrete and binder system that is preapproved. Use the concrete in the blocked out areas on both sides of the bridge deck joints as indicated on the plans.

2.0 MATERIALS

Provide materials that comply with the following minimum requirements at 14 days (or at the end of the specified curing time).

ELASTOMERIC CONCRETE PROPERTIES	TEST METHOD	MINIMUM REQUIREMENT
Compressive Strength, psi	ASTM D695	2000
5% Deflection Resilience	ASTM D695	95
Splitting Tensile Strength, psi	ASTM D3967	625
Bond Strength to Concrete, psi	ASTM D882 (D882M)	450
Durometer Hardness	ASTM D2240	50

BINDER PROPERTIES (without aggregate)	TEST METHOD	MINIMUM REQUIREMENT
Tensile Strength, psi	ASTM D638	1000
Ultimate Elongation	ASTM D638	150%
Tear Resistance, lb/in	ASTM D624	200

In addition to the requirements above, the elastomeric concrete must be resistant to water, chemical, UV and ozone exposure and withstand temperature extremes. Elastomeric concrete systems requiring preheated aggregates are not allowed.

3.0 PREQUALIFICATION

Manufacturers of elastomeric concrete materials shall submit samples (including aggregate, primer and binder materials) and a Type 3 certification in accordance with Article 106-3 of the Standard Specifications for prequalification to:

North Carolina Department of Transportation
Materials and Tests Unit
1801 Blue Ridge Road
Raleigh, NC 27607

Prequalification will be determined for the system. Individual components will not be evaluated, nor will individual components of previously evaluated systems be deemed prequalified for use.

The submitted binder (a minimum volume of 1 gallon) and corresponding aggregate samples will be evaluated for compliance with the Materials requirements specified above. Systems satisfying all of the Materials requirements will be prequalified for a one year period. Before the end of this period new product samples shall be resubmitted for prequalification evaluation.

If, at any time, any formulation or component modifications are made to a prequalified system that system will no longer be approved for use.

4.0 INSTALLATION

The elastomeric concrete shall not be placed until the reinforced concrete deck slab has cured for seven full days and reached a minimum strength of 3000 psi.

Provide a manufacturer's representative at the bridge site during the installation of the elastomeric concrete to ensure that all steps being performed comply with all manufacturer installation requirements including, but not limited to weather conditions (ambient temperature, relative humidity, precipitation, wind, etc), concrete deck surface preparation, binder and aggregate mixing, primer application, elastomeric concrete placement, curing conditions and minimum curing time before joint exposure to traffic. Do not place elastomeric concrete if the ambient air or surface temperature is below 45°F.

Prepare the concrete surface within 48 hours prior to placing the elastomeric concrete. Before placing the elastomeric concrete, all concrete surfaces shall be thoroughly cleaned and dry. Sandblast the concrete surface in the blockout and clear the surface of all loose debris. Do not place the elastomeric concrete until the surface preparation is completed and approved.

Prepare and apply a primer, as per manufacturer's recommendations, to all concrete faces to be in contact with elastomeric concrete, and to areas specified by the manufacturer.

Prepare, batch, and place the elastomeric concrete in accordance with the manufacturer's instructions. Place the elastomeric concrete in the areas specified on the plans while the primer is still tacky and within 2 hours after applying the primer. Trowel the elastomeric concrete to a smooth finish.

The joint opening in the elastomeric concrete shall match the formed opening in the concrete deck prior to sawing the joint.

5.0 FIELD SAMPLING

Provide additional production material to allow freshly mixed elastomeric concrete to be sampled for acceptance. A minimum of six 2 inch cube molds and three 3x6 inch cylinders will be taken by the Department for each day's production. Compression, splitting tensile, and durometer hardness testing will be performed by the Department to determine acceptance. Materials failing to meet the requirements listed above are subject to removal and replacement at no cost to the Department.

6.0 BASIS OF PAYMENT

No separate payment will be made for elastomeric concrete. The lump sum contract price bid for "Foam Joint Seals" or "Synthetic Rubber Expansion Joint Seal" will be full compensation for furnishing and placing the Elastomeric Concrete.

FOAM JOINT SEALS

(9-27-12)

1.0 SEALS

Use preformed seals compatible with concrete and resistant to abrasion, oxidation, oils, gasoline, salt and other materials that are spilled on or applied to the surface. Use a resilient, UV stable, preformed, impermeable, flexible, expansion joint seal. The joint seal shall consist of low-density, closed cell, cross-linked polyethylene non-extrudable, foam. The joint seal shall contain no EVA (Ethylene Vinyl Acetate). Cell generation shall be achieved by being physically blown using nitrogen. No chemical blowing agents shall be used in the cell generation process.

Use seals manufactured with grooves $1/8'' \pm$ wide by $1/8'' \pm$ deep and spaced between $1/4''$ and $1/2''$ apart along the bond surface running the length of the joint. Use seals with a depth that meets the manufacturer's recommendation, but is not less than 70% of the uncompressed width. Provide a seal designed so that, when compressed, the center portion of the top does not extend upward above the original height of the seal by more than $1/4''$. Provide a seal that has a working range of 30% tension and 60% compression and meets the requirements given below.

TEST	TEST METHOD	REQUIREMENT
Tensile strength	ASTM D3575-08, Suffix T	110 – 130 psi
Compression Set	ASTM D1056 Suffix B, 2 hr recovery	10% - 16%
Water Absorption	ASTM D3575	< 0.03 lb/ft ²
Elongation at Break	ASTM D3575	180% - 210%
Tear Strength	ASTM D624 (D3575-08, Suffix G)	14 – 20 pli
Density	ASTM D3575-08, Suffix W, Method A	1.8 – 2.2 lb/ft ³
Toxicity	ISO-10993.5	Pass (not cytotoxic)

Have the top of the joint seal clearly shop marked. Inspect the joint seals upon receipt to ensure that the marks are clearly visible before installation.

2.0 BONDING ADHESIVE

Use a two component, 100% solid, modified epoxy adhesive supplied by the joint seal manufacturer that meets the requirements given below.

TEST	TEST METHOD	REQUIREMENT
Tensile strength	ASTM D638	3000 psi (min.)
Compressive strength	ASTM D695	7000 psi (min.)
Hardness	Shore D Scale	75-85 psi
Water Absorption	ASTM D570	0.25% by weight max.
Elongation to Break	ASTM D638	5% (max.)
Bond Strength	ASTM C882	2000 psi (min.)

Use an adhesive that is workable to 40°F. When installing in ambient air or surface temperatures below 40°F or for application on moist, difficult to dry concrete surfaces, use an adhesive specified by the manufacturer of the joint seal.

3.0 SAWING THE JOINT

The joint opening shall be initially formed to the width shown on the plans including the blockout for the elastomeric concrete.

The elastomeric concrete shall have sufficient time to cure such that no damage can occur to the elastomeric concrete prior to sawing to the final width and depth as specified in the plans.

When sawing the joint to receive the foam seal, always use a rigid guide to control the saw in the desired direction. To control the saw and to produce a straight line as indicated on the plans, anchor and positively connect a template or a track to the bridge deck. Do not

saw the joint by visual means such as a chalk line. Fill the holes used for holding the template or track to the deck with an approved, flowable non-shrink, non-metallic grout.

Saw cut to the desired width and depth in one or two passes of the saw by placing and spacing two metal blades on the saw shaft to the desired width for the joint opening.

The desired depth is the depth of the seal plus 1/4" above the top of the seal plus approximately 1" below the bottom of the seal. An irregular bottom of sawed joint is permitted as indicated on the plans. Grind exposed corners on saw cut edges to a 1/4" chamfer.

Saw cut a straight joint, centered over the formed opening and to the desired width specified in the plans. Prevent any chipping or damage to the sawed edges of the joint.

Remove any staining or deposited material resulting from sawing with a wet blade to the satisfaction of the Engineer.

4.0 PREPARATION OF SAWED JOINT FOR SEAL INSTALLATION

The elastomeric concrete shall cure a minimum of 24 hours prior to seal installation.

After sawing the joint, the Engineer will thoroughly inspect the sawed joint opening for spalls, popouts, cracks, etc. All necessary repairs will be made by the Contractor prior to blast cleaning and installing the seal.

Clean the joints by sandblasting with clean dry sand immediately before placing the bonding agent. Sandblast the joint opening to provide a firm, clean joint surface free of curing compound, loose material and any foreign matter. Sandblast the joint opening without causing pitting or uneven surfaces. The aggregate in the elastomeric concrete may be exposed after sandblasting.

After blasting, either brush the surface with clean brushes made of hair, bristle or fiber, blow the surface with compressed air, or vacuum the surface until all traces of blast products and abrasives are removed from the surface, pockets, and corners.

If nozzle blasting is used to clean the joint opening, use compressed air that does not contain detrimental amounts of water or oil.

Examine the blast cleaned surface and remove any traces of oil, grease or smudge deposited in the cleaning operations.

Bond the seal to the blast cleaned surface on the same day the surface is blast cleaned.

5.0 SEAL INSTALLATION

Install the joint seal according to the manufacturer's procedures and recommendations and as recommended below. Do not install the joint seal if the ambient air or surface temperature is below 45°F. Have a manufacturer's certified trained factory representative present during the installation of the first seal of the project.

Before installing the joint seal, check the uninstalled seal length to insure the seal is the same length as the deck opening. When the joint seal requires splicing, use the heat welding method by placing the joint material ends against a teflon heating iron of 425-475°F for 7 - 10 seconds, then pressing the ends together tightly. Do not test the welding until the material has completely cooled.

Begin installation by protecting the top edges of the concrete deck adjacent to the vertical walls of the joint as a means to minimize clean up. After opening both cans of the bonding agent, stir each can using separate stirring rods for each component to prevent premature curing of the bonding agent. Pour the two components, at the specified mixing ratio, into a clean mixing bucket. Mix the components with a low speed drill (400 rpm max.) until a uniform gray color is achieved without visible marbling. Apply bonding agent to both sides of the elastomeric concrete as well as both sides of the joint seal, making certain to completely fill the grooves with epoxy. With gloved hands, compress the joint seal and with the help of a blunt probe, push the seal into the joint opening until the seal is recessed approximately 1/4" below the surface. When pushing down on the joint seal, apply pressure only in a downward direction. Do not push the joint seal into the joint opening at an angle that would stretch the material. Seals that are stretched during installation shall be removed and rejected. Once work on placing a seal begins, do not stop until it is completed. Clean the excess epoxy from the top of the joint seal immediately with a trowel. Do not use solvents or any cleaners to remove the excess epoxy from the top of the seal. Remove the protective cover at the joint edges and check for any excess epoxy on the surface. Remove excess epoxy with a trowel, the use of solvents or any cleaners will not be allowed.

The installed system shall be watertight and will be monitored until final inspection and approval. Do not place pavement markings on top of foam joint seals.

6.0 BASIS OF PAYMENT

Payment for all foam joint seals will be at the lump sum contract price bid for "Foam Joint Seals". Prices and payment will be full compensation for furnishing all material, including elastomeric concrete, labor, tools and equipment necessary for installing these units in place and accepted.

FALSEWORK AND FORMWORK

(4-5-12)

1.0 DESCRIPTION

Use this Special Provision as a guide to develop temporary works submittals required by the Standard Specifications or other provisions; no additional submittals are required herein. Such temporary works include, but are not limited to, falsework and formwork.

Falsework is any temporary construction used to support the permanent structure until it becomes self-supporting. Formwork is the temporary structure or mold used to retain plastic or fluid concrete in its designated shape until it hardens. Access scaffolding is a temporary structure that functions as a work platform that supports construction personnel, materials, and tools, but is not intended to support the structure. Scaffolding systems that are used to temporarily support permanent structures (as opposed to functioning as work platforms) are considered to be falsework under the definitions given. Shoring is a component of falsework

such as horizontal, vertical, or inclined support members. Where the term “temporary works” is used, it includes all of the temporary facilities used in bridge construction that do not become part of the permanent structure.

Design and construct safe and adequate temporary works that will support all loads imposed and provide the necessary rigidity to achieve the lines and grades shown on the plans in the final structure.

2.0 MATERIALS

Select materials suitable for temporary works; however, select materials that also ensure the safety and quality required by the design assumptions. The Engineer has authority to reject material on the basis of its condition, inappropriate use, safety, or nonconformance with the plans. Clearly identify allowable loads or stresses for all materials or manufactured devices on the plans. Revise the plan and notify the Engineer if any change to materials or material strengths is required.

3.0 DESIGN REQUIREMENTS

A. Working Drawings

Provide working drawings for items as specified in the contract, or as required by the Engineer, with design calculations and supporting data in sufficient detail to permit a structural and safety review of the proposed design of the temporary work.

On the drawings, show all information necessary to allow the design of any component to be checked independently as determined by the Engineer.

When concrete placement is involved, include data such as the drawings of proposed sequence, rate of placement, direction of placement, and location of all construction joints. Submit the number of copies as called for by the contract.

When required, have the drawings and calculations prepared under the guidance of, and sealed by, a North Carolina Registered Professional Engineer who is knowledgeable in temporary works design.

If requested by the Engineer, submit with the working drawings manufacturer’s catalog data listing the weight of all construction equipment that will be supported on the temporary work. Show anticipated total settlements and/or deflections of falsework and forms on the working drawings. Include falsework footing settlements, joint take-up, and deflection of beams or girders.

As an option for the Contractor, overhang falsework hangers may be uniformly spaced, at a maximum of 36 inches, provided the following conditions are met:

Member Type (PCG)	Member Depth, (inches)	Max. Overhang Width, (inches)	Max. Slab Edge Thickness, (inches)	Max. Screed Wheel Weight, (lbs.)	Bracket Min. Vertical Leg Extension, (inches)
II	36	39	14	2000	26
III	45	42	14	2000	35

IV	54	45	14	2000	44
MBT	63	51	12	2000	50
MBT	72	55	12	1700	48

Overhang width is measured from the centerline of the girder to the edge of the deck slab.

For Type II, III & IV prestressed concrete girders (PCG), 45-degree cast-in-place half hangers and rods must have a minimum safe working load of 6,000 lbs.

For MBT prestressed concrete girders, 45-degree angle holes for falsework hanger rods shall be cast through the girder top flange and located, measuring along the top of the member, 1'-2 ½" from the edge of the top flange. Hanger hardware and rods must have a minimum safe working load of 6,000 lbs.

The overhang bracket provided for the diagonal leg shall have a minimum safe working load of 3,750 lbs. The vertical leg of the bracket shall extend to the point that the heel bears on the girder bottom flange, no closer than 4 inches from the bottom of the member. However, for 72-inch members, the heel of the bracket shall bear on the web, near the bottom flange transition.

Provide adequate overhang falsework and determine the appropriate adjustments for deck geometry, equipment, casting procedures and casting conditions.

If the optional overhang falsework spacing is used, indicate this on the falsework submittal and advise the girder producer of the proposed details. Failure to notify the Engineer of hanger type and hanger spacing on prestressed concrete girder casting drawings may delay the approval of those drawings.

Falsework hangers that support concentrated loads and are installed at the edge of thin top flange concrete girders (such as bulb tee girders) shall be spaced so as not to exceed 75% of the manufacturer's stated safe working load. Use of dual leg hangers (such as Meadow Burke HF-42 and HF-43) are not allowed on concrete girders with thin top flanges. Design the falsework and forms supporting deck slabs and overhangs on girder bridges so that there will be no differential settlement between the girders and the deck forms during placement of deck concrete.

When staged construction of the bridge deck is required, detail falsework and forms for screed and fluid concrete loads to be independent of any previous deck pour components when the mid-span girder deflection due to deck weight is greater than ¼".

Note on the working drawings any anchorages, connectors, inserts, steel sleeves or other such devices used as part of the falsework or formwork that remains in the permanent structure. If the plan notes indicate that the structure contains the necessary corrosion protection required for a Corrosive Site, epoxy coat, galvanize or metalize these devices. Electroplating will not be allowed. Any coating required by the Engineer will be considered incidental to the various pay items requiring temporary works.

Design falsework and formwork requiring submittals in accordance with the 1995 AASHTO *Guide Design Specifications for Bridge Temporary Works* except as noted herein.

1. Wind Loads

Table 2.2 of Article 2.2.5.1 is modified to include wind velocities up to 110 mph. In addition, Table 2.2A is included to provide the maximum wind speeds by county in North Carolina.

Table 2.2 - Wind Pressure Values

Height Zone feet above ground	Pressure, lb/ft ² for Indicated Wind Velocity, mph				
	70	80	90	100	110
0 to 30	15	20	25	30	35
30 to 50	20	25	30	35	40
50 to 100	25	30	35	40	45
over 100	30	35	40	45	50

2. Time of Removal

The following requirements replace those of Article 3.4.8.2.

Do not remove forms until the concrete has attained strengths required in Article 420-16 of the Standard Specifications and these Special Provisions.

Do not remove forms until the concrete has sufficient strength to prevent damage to the surface.

Table 2.2A - Steady State Maximum Wind Speeds by Counties in North Carolina

COUNTY	25 YR (mph)	COUNTY	25 YR (mph)	COUNTY	25 YR (mph)
Alamance	70	Franklin	70	Pamlico	100
Alexander	70	Gaston	70	Pasquotank	100
Alleghany	70	Gates	90	Pender	100
Anson	70	Graham	80	Perquimans	100
Ashe	70	Granville	70	Person	70
Avery	70	Greene	80	Pitt	90
Beaufort	100	Guilford	70	Polk	80
Bertie	90	Halifax	80	Randolph	70
Bladen	90	Harnett	70	Richmond	70
Brunswick	100	Haywood	80	Robeson	80
Buncombe	80	Henderson	80	Rockingham	70
Burke	70	Hertford	90	Rowan	70
Cabarrus	70	Hoke	70	Rutherford	70
Caldwell	70	Hyde	110	Sampson	90
Camden	100	Iredell	70	Scotland	70
Carteret	110	Jackson	80	Stanley	70

Caswell	70	Johnston	80	Stokes	70
Catawba	70	Jones	100	Surry	70
Cherokee	80	Lee	70	Swain	80
Chatham	70	Lenoir	90	Transylvania	80
Chowan	90	Lincoln	70	Tyrell	100
Clay	80	Macon	80	Union	70
Cleveland	70	Madison	80	Vance	70
Columbus	90	Martin	90	Wake	70
Craven	100	McDowell	70	Warren	70
Cumberland	80	Mecklenburg	70	Washington	100
Currituck	100	Mitchell	70	Watauga	70
Dare	110	Montgomery	70	Wayne	80
Davidson	70	Moore	70	Wilkes	70
Davie	70	Nash	80	Wilson	80
Duplin	90	New Hanover	100	Yadkin	70
Durham	70	Northampton	80	Yancey	70
Edgecombe	80	Onslow	100		
Forsyth	70	Orange	70		

B. Review and Approval

The Engineer is responsible for the review and approval of temporary works' drawings.

Submit the working drawings sufficiently in advance of proposed use to allow for their review, revision (if needed), and approval without delay to the work.

The time period for review of the working drawings does not begin until complete drawings and design calculations, when required, are received by the Engineer.

Do not start construction of any temporary work for which working drawings are required until the drawings have been approved. Such approval does not relieve the Contractor of the responsibility for the accuracy and adequacy of the working drawings.

4.0 CONSTRUCTION REQUIREMENTS

All requirements of Section 420 of the Standard Specifications apply.

Construct temporary works in conformance with the approved working drawings. Ensure that the quality of materials and workmanship employed is consistent with that assumed in the design of the temporary works. Do not weld falsework members to any portion of the permanent structure unless approved. Show any welding to the permanent structure on the approved construction drawings.

Provide tell-tales attached to the forms and extending to the ground, or other means, for accurate measurement of falsework settlement. Make sure that the anticipated compressive settlement and/or deflection of falsework does not exceed 1 inch. For cast-in-place concrete structures, make sure that the calculated deflection of falsework flexural members does not

exceed 1/240 of their span regardless of whether or not the deflection is compensated by camber strips.

A. Maintenance and Inspection

Inspect and maintain the temporary work in an acceptable condition throughout the period of its use. Certify that the manufactured devices have been maintained in a condition to allow them to safely carry their rated loads. Clearly mark each piece so that its capacity can be readily determined at the job site.

Perform an in-depth inspection of an applicable portion(s) of the temporary works, in the presence of the Engineer, not more than 24 hours prior to the beginning of each concrete placement. Inspect other temporary works at least once a month to ensure that they are functioning properly. Have a North Carolina Registered Professional Engineer inspect the cofferdams, shoring, sheathing, support of excavation structures, and support systems for load tests prior to loading.

B. Foundations

Determine the safe bearing capacity of the foundation material on which the supports for temporary works rest. If required by the Engineer, conduct load tests to verify proposed bearing capacity values that are marginal or in other high-risk situations.

The use of the foundation support values shown on the contract plans of the permanent structure is permitted if the foundations are on the same level and on the same soil as those of the permanent structure.

Allow for adequate site drainage or soil protection to prevent soil saturation and washout of the soil supporting the temporary works supports.

If piles are used, the estimation of capacities and later confirmation during construction using standard procedures based on the driving characteristics of the pile is permitted. If preferred, use load tests to confirm the estimated capacities; or, if required by the Engineer conduct load tests to verify bearing capacity values that are marginal or in other high risk situations.

The Engineer reviews and approves the proposed pile and soil bearing capacities.

5.0 REMOVAL

Unless otherwise permitted, remove and keep all temporary works upon completion of the work. Do not disturb or otherwise damage the finished work.

Remove temporary works in conformance with the contract documents. Remove them in such a manner as to permit the structure to uniformly and gradually take the stresses due to its own weight.

6.0 METHOD OF MEASUREMENT

Unless otherwise specified, temporary works will not be directly measured.

7.0 BASIS OF PAYMENT

Payment at the contract unit prices for the various pay items requiring temporary works will be full compensation for the above falsework and formwork.

SUBMITTAL OF WORKING DRAWINGS

(2-10-12)

1.0 GENERAL

Submit working drawings in accordance with Article 105-2 of the *Standard Specifications* and this provision. For this provision, “submittals” refers to only those listed in this provision. The list of submittals contained herein does not represent a list of required submittals for the project. Submittals are only necessary for those items as required by the contract. Make submittals that are not specifically noted in this provision directly to the Resident Engineer. Either the Structure Design Unit or the Geotechnical Engineering Unit or both units will jointly review submittals.

If a submittal contains variations from plan details or specifications or significantly affects project cost, field construction or operations, discuss the submittal with and submit all copies to the Resident Engineer. State the reason for the proposed variation in the submittal. To minimize review time, make sure all submittals are complete when initially submitted. Provide a contact name and information with each submittal. Direct any questions regarding submittal requirements to the Resident Engineer, Structure Design Unit contacts or the Geotechnical Engineering Unit contacts noted below.

In order to facilitate in-plant inspection by NCDOT and approval of working drawings, provide the name, address and telephone number of the facility where fabrication will actually be done if different than shown on the title block of the submitted working drawings. This includes, but is not limited to, precast concrete items, prestressed concrete items and fabricated steel or aluminum items.

2.0 ADDRESSES AND CONTACTS

For submittals to the Structure Design Unit, use the following addresses:

Via US mail:

Mr. G. R. Perfetti, P. E.
State Structures Engineer
North Carolina Department
of Transportation
Structures Management Unit
1581 Mail Service Center
Raleigh, NC 27699-1581

Attention: Mr. P. D. Lambert, P. E.

Via other delivery service:

Mr. G. R. Perfetti, P. E.
State Structures Engineer
North Carolina Department
of Transportation
Structures Management Unit
1000 Birch Ridge Drive
Raleigh, NC 27610

Attention: Mr. P. D. Lambert, P. E.

Submittals may also be made via email.

Send submittals to: plambert@ncdot.gov (Paul Lambert)

Send an additional e-copy of the submittal to the following address:

jgaither@ncdot.gov (James Gaither)

jlbolden@ncdot.gov (James Bolden)

For submittals to the Geotechnical Engineering Unit, use the following addresses:

For projects in Divisions 1-7, use the following Eastern Regional Office address:

Via US mail:

Mr. K. J. Kim, Ph. D., P. E.
Eastern Regional Geotechnical
Manager
North Carolina Department
of Transportation
Geotechnical Engineering Unit
Eastern Regional Office
1570 Mail Service Center
Raleigh, NC 27699-1570

Via other delivery service:

Mr. K. J. Kim, Ph. D., P. E.
Eastern Regional Geotechnical
Manager
North Carolina Department
of Transportation
Geotechnical Engineering Unit
Eastern Regional Office
3301 Jones Sausage Road, Suite 100
Garner, NC 27529

For projects in Divisions 8-14, use the following Western Regional Office address:

Via US mail:

Mr. John Pilipchuk, L. G., P. E.
Western Regional Geotechnical
Manager
North Carolina Department
of Transportation
Geotechnical Engineering Unit
Western Regional Office
5253 Z Max Boulevard
Harrisburg, NC 28075

Via other delivery service:

Mr. John Pilipchuk, L. G., P. E.
Western Region Geotechnical
Manager
North Carolina Department
of Transportation
Geotechnical Engineering Unit
Western Regional Office
5253 Z Max Boulevard
Harrisburg, NC 28075

The status of the review of structure-related submittals sent to the Structure Design Unit can be viewed from the Unit's web site, via the "Contractor Submittal" link.

Direct any questions concerning submittal review status, review comments or drawing markups to the following contacts:

Primary Structures Contact:

Paul Lambert
(919) 707 – 6407
(919) 250 – 4082 facsimile
plambert@ncdot.gov

Secondary Structures Contacts: James Gaither
(919) 707 – 6409
James Bolden
(919) 707 – 6408

Eastern Regional Geotechnical Contact (Divisions 1-7):
K. J. Kim
(919) 662 – 4710
(919) 662 – 3095 facsimile
kkim@ncdot.gov

Western Regional Geotechnical Contact (Divisions 8-14):
John Pilipchuk
(704) 455 – 8902
(704) 455 – 8912 facsimile
jpilipchuk@ncdot.gov

3.0 SUBMITTAL COPIES

Furnish one complete copy of each submittal, including all attachments, to the Resident Engineer. At the same time, submit the number of hard copies shown below of the same complete submittal directly to the Structure Design Unit and/or the Geotechnical Engineering Unit.

The first table below covers “Structure Submittals”. The Resident Engineer will receive review comments and drawing markups for these submittals from the Structure Design Unit. The second table in this section covers “Geotechnical Submittals”. The Resident Engineer will receive review comments and drawing markups for these submittals from the Geotechnical Engineering Unit.

Unless otherwise required, submit one set of supporting calculations to either the Structure Design Unit or the Geotechnical Engineering Unit unless both units require submittal copies in which case submit a set of supporting calculations to each unit. Provide additional copies of any submittal as directed.

STRUCTURE SUBMITTALS

Submittal	Copies Required by Structure Design Unit	Copies Required by Geotechnical Engineering Unit	Contract Reference Requiring Submittal ¹
Arch Culvert Falsework	5	0	Plan Note, SN Sheet & “Falsework and Formwork”
Box Culvert Falsework ⁷	5	0	Plan Note, SN Sheet & “Falsework and Formwork”
Cofferdams	6	2	Article 410-4

Foam Joint Seals ⁶	9	0	“Foam Joint Seals”
Expansion Joint Seals (hold down plate type with base angle)	9	0	“Expansion Joint Seals”
Expansion Joint Seals (modular)	2, then 9	0	“Modular Expansion Joint Seals”
Expansion Joint Seals (strip seals)	9	0	“Strip Seals”
Falsework & Forms ² (substructure)	8	0	Article 420-3 & “Falsework and Formwork”
Falsework & Forms (superstructure)	8	0	Article 420-3 & “Falsework and Formwork”
Girder Erection over Railroad	5	0	Railroad Provisions
Maintenance and Protection of Traffic Beneath Proposed Structure	8	0	“Maintenance and Protection of Traffic Beneath Proposed Structure at Station ____”
Metal Bridge Railing	8	0	Plan Note
Metal Stay-in-Place Forms	8	0	Article 420-3
Metalwork for Elastomeric Bearings ^{4,5}	7	0	Article 1072-8
Miscellaneous Metalwork ^{4,5}	7	0	Article 1072-8
Optional Disc Bearings ⁴	8	0	“Optional Disc Bearings”
Overhead and Digital Message Signs (DMS) (metalwork and foundations)	13	0	Applicable Provisions
Placement of Equipment on Structures (cranes, etc.)	7	0	Article 420-20
Pot Bearings ⁴	8	0	“Pot Bearings”
Precast Concrete Box Culverts	2, then 1 reproducible	0	“Optional Precast Reinforced Concrete Box Culvert at Station ____”
Prestressed Concrete Cored Slab (detensioning sequences) ³	6	0	Article 1078-11
Prestressed Concrete Deck Panels	6 and 1 reproducible	0	Article 420-3

Prestressed Concrete Girder (strand elongation and detensioning sequences)	6	0	Articles 1078-8 and 1078- 11
Removal of Existing Structure over Railroad	5	0	Railroad Provisions
Revised Bridge Deck Plans (adaptation to prestressed deck panels)	2, then 1 reproducible	0	Article 420-3
Revised Bridge Deck Plans (adaptation to modular expansion joint seals)	2, then 1 reproducible	0	“Modular Expansion Joint Seals”
Sound Barrier Wall (precast items)	10	0	Article 1077-2 & “Sound Barrier Wall”
Sound Barrier Wall Steel Fabrication Plans ⁵	7	0	Article 1072-8 & “Sound Barrier Wall”
Structural Steel ⁴	2, then 7	0	Article 1072-8 Article 400-3 & “Construction,
Temporary Detour Structures	10	2	Maintenance and Removal of Temporary Structure at Station _____”
TFE Expansion Bearings ⁴	8	0	Article 1072-8

FOOTNOTES

1. References are provided to help locate the part of the contract where the submittals are required. References in quotes refer to the provision by that name. Articles refer to the *Standard Specifications*.
2. Submittals for these items are necessary only when required by a note on plans.
3. Submittals for these items may not be required. A list of pre-approved sequences is available from the producer or the Materials & Tests Unit.
4. The fabricator may submit these items directly to the Structure Design Unit.
5. The two sets of preliminary submittals required by Article 1072-8 of the *Standard Specifications* are not required for these items.
6. Submittals for Fabrication Drawings are not required. Submittals for Catalogue Cuts of Proposed Material are required. See Section 5.A of the referenced provision.
7. Submittals are necessary only when the top slab thickness is 18” or greater.

GEOTECHNICAL SUBMITTALS

Submittal	Copies Required by Geotechnical Engineering Unit	Copies Required by Structure Design Unit	Contract Reference Requiring Submittal¹
Drilled Pier Construction Plans ²	1	0	Subarticle 411-3(A)
Crosshole Sonic Logging (CSL) Reports ²	1	0	Subarticle 411-5(A)(2)
Pile Driving Equipment Data Forms ^{2,3}	1	0	Subarticle 450-3(D)(2)
Pile Driving Analyzer (PDA) Reports ²	1	0	Subarticle 450-3(F)(3)
Retaining Walls ⁴	8 drawings, 2 calculations	2 drawings	Applicable Provisions
Temporary Shoring ⁴	5 drawings, 2 calculations	2 drawings	“Temporary Shoring” & “Temporary Soil Nail Walls”

FOOTNOTES

- References are provided to help locate the part of the contract where the submittals are required. References in quotes refer to the provision by that name. Subarticles refer to the *Standard Specifications*.
- Submit one hard copy of submittal to the Resident or Bridge Maintenance Engineer. Submit a second copy of submittal electronically (PDF via email) or by facsimile, US mail or other delivery service to the appropriate Geotechnical Engineering Unit regional office. Electronic submission is preferred.
- The Pile Driving Equipment Data Form is available from:
www.ncdot.org/doh/preconstruct/highway/geotech/formdet/
See second page of form for submittal instructions.
- Electronic copy of submittal is required. See referenced provision.

SAND LIGHTWEIGHT CONCRETE**(SPECIAL) (9-30-11)**

Reinforced concrete deck slabs shall be constructed in accordance with Section 420 of the Standard Specifications for Roads and Structures.

Concrete parapets shall be constructed in accordance with Section 460 of the Standard Specifications for Roads and Structures.

Use sand lightweight concrete, as noted on the plans, that meets the requirements of this Special Provision.

Sand lightweight concrete is composed of portland cement, fine aggregate, lightweight coarse aggregate, water, and admixtures. Provide sand lightweight concrete that complies with the applicable requirements of Sections 420, 1000, and 1024 of the Standard Specifications and the additional requirements herein.

Submit a mix design from a testing laboratory approved by the NC Division of Highways for approval at least 35 days prior to the proposed use. Provide a mix meeting Table 1000-1 of the Standard Specifications and the following design criteria:

TEST	TEST METHOD	REQUIREMENT
Max. Unit Weight, plastic, lbs/ft ³	AASHTO T121	120
Max. Unit Weight, dry, lbs/ft ³	ASTM C567 using equilibrium air dried unit weight	115
Min. Relative Dynamic Modulus, (percent)	AASHTO T161 Procedure A	80

When submitting the mix design, include the source of the aggregates, cement, and admixtures and the gradation, specific gravity and fineness modulus (fine aggregate only) of the aggregates. Submit test results showing the mix design conforms to the criteria, including the 28 day compressive strength of a minimum of six cylinders. Provide a mix design that produces an average compressive strength sufficient to ensure that a minimum strength of 4500 psi is achieved in the field.

Produce an additional mix in accordance with AASHTO M195 to determine the drying shrinkage. The maximum drying shrinkage for this mix is 0.07%.

For lightweight aggregate, use expanded shale or slate that meets the requirements of AASHTO M195. Grade the lightweight aggregate in accordance with 1014-2(E)(6).

Determine the soundness in accordance with AASHTO T104. Loss of more than 10% of the lightweight aggregate in five cycles of the accelerated soundness test using sodium sulfate is not permitted.

Ensure the lightweight aggregate is in a saturated surface-dry condition when it is proportioned and incorporated into the mix.

CRANE SAFETY

(8-15-05)

Comply with the manufacturer specifications and limitations applicable to the operation of any and all cranes and derricks. Prime contractors, sub-contractors, and fully operated rental companies shall comply with the current Occupational Safety and Health Administration regulations (OSHA).

Submit all items listed below to the Engineer prior to beginning crane operations involving critical lifts. A critical lift is defined as any lift that exceeds 75 percent of the manufacturer's crane chart capacity for the radius at which the load will be lifted or requires the use of more than one crane. Changes in personnel or equipment must be reported to the Engineer and all applicable items listed below must be updated and submitted prior to continuing with crane operations.

Crane Safety Submittal List

- **Competent Person:** Provide the name and qualifications of the "Competent Person" responsible for crane safety and lifting operations. The named competent person will have the responsibility and authority to stop any work activity due to safety concerns.
- **Riggers:** Provide the qualifications and experience of the persons responsible for rigging operations. Qualifications and experience should include, but not be limited to, weight calculations, center of gravity determinations, selection and inspection of sling and rigging equipment, and safe rigging practices.
- **Crane Inspections:** Inspection records for all cranes shall be current and readily accessible for review upon request.
- **Certifications:** By July 1, 2006, crane operators performing critical lifts shall be certified by NC CCO (National Commission for the Certification of Crane Operators), or satisfactorily complete the Carolinas AGC's Professional Crane Operator's Proficiency Program. Other approved nationally accredited programs will be considered upon request. All crane operators shall also have a current CDL medical card. Submit a list of anticipated critical lifts and corresponding crane operator(s). Include current certification for the type of crane operated (small hydraulic, large hydraulic, small lattice, large lattice) and medical evaluations for each operator.

GROUT FOR STRUCTURES

(9-30-11)

1.0 DESCRIPTION

This special provision addresses grout for use in pile blockouts, grout pockets, shear keys, dowel holes and recesses for structures. This provision does not apply to grout placed in post-tensioning ducts for bridge beams, girders, or decks. Mix and place grout in accordance with the manufacturer's recommendations, the applicable sections of the Standard Specifications and this provision.

2.0 MATERIAL REQUIREMENTS

Use a Department approved pre-packaged, non-shrink, non-metallic grout. Contact the Materials and Tests Unit for a list of approved pre-packaged grouts and consult the manufacturer to determine if the pre-packaged grout selected is suitable for the required application.

When using an approved pre-packaged grout, a grout mix design submittal is not required.

The grout shall be free of soluble chlorides and contain less than one percent soluble sulfate. Supply water in compliance with Article 1024-4 of the Standard Specifications.

Aggregate may be added to the mix only where recommended or permitted by the manufacturer and Engineer. The quantity and gradation of the aggregate shall be in accordance with the manufacturer's recommendations.

Admixtures, if approved by the Department, shall be used in accordance with the manufacturer's recommendations. The manufacture date shall be clearly stamped on each container. Admixtures with an expired shelf life shall not be used.

The Engineer reserves the right to reject material based on unsatisfactory performance.

Initial setting time shall not be less than 10 minutes when tested in accordance with ASTM C266.

Test the expansion and shrinkage of the grout in accordance with ASTM C1090. The grout shall expand no more than 0.2% and shall exhibit no shrinkage. Furnish a Type 4 material certification showing results of tests conducted to determine the properties listed in the Standard Specifications and to assure the material is non-shrink.

Unless required elsewhere in the contract the compressive strength at 3 days shall be at least 5000 psi. Compressive strength in the laboratory shall be determined in accordance with ASTM C109 except the test mix shall contain only water and the dry manufactured material. Compressive strength in the field will be determined by molding and testing 4" x 8" cylinders in accordance with AASHTO T22. Construction loading and traffic loading shall not be allowed until the 3 day compressive strength is achieved.

When tested in accordance with ASTM C666, Procedure A, the durability factor of the grout shall not be less than 80.

3.0 SAMPLING AND PLACEMENT

Place and maintain components in final position until grout placement is complete and accepted. Concrete surfaces to receive grout shall be free of defective concrete, laitance, oil, grease and other foreign matter. Saturate concrete surfaces with clean water and remove excess water prior to placing grout.

Do not place grout if the grout temperature is less than 50°F or more than 90°F or if the air temperature measured at the location of the grouting operation in the shade away from artificial heat is below 45°F.

Provide grout at a rate that permits proper handling, placing and finishing in accordance with the manufacturer's recommendations unless directed otherwise by the Engineer. Use grout free of any lumps and undispersed cement. Agitate grout continuously before placement.

Control grout delivery so the interval between placing batches in the same component does not exceed 20 minutes.

The Engineer will determine the locations to sample grout and the number and type of samples collected for field and laboratory testing. The compressive strength of the grout will be considered the average compressive strength test results of 3 cube or 2 cylinder specimens at 28 days.

4.0 BASIS OF PAYMENT

No separate payment will be made for "Grout for Structures". The cost of the material, equipment, labor, placement, and any incidentals necessary to complete the work shall be considered incidental to the structure item requiring grout.

STRUCTURAL STEEL MODIFICATION AT BRIDGE NO. 65

SPECIAL

1.0 GENERAL

Structural steel modification Bridge Number 65 in Rowan County consists of adding new welded stud shear connectors to Spans 'A' and 'D' according to the contract drawings, and replacing any shear studs damaged during the demolition process on Spans 'B' and 'C'.

2.0 MATERIALS

See Standard Notes sheet in contract drawings.

3.0 INSTALLATION

Shear studs must be attached to the existing beams in Spans 'A' and 'D' according to the contract drawings. Refer to Standard Specification for welding procedure.

4.0 BASIS OF PAYMENT

The price and payment below will be full compensation for all items required for structural steel modification.

Structural Steel Modification at Bridge #65 will be paid at the contract lump sum price.

Payment will be made under:

Pay Item

Structural Steel Modification at Bridge #65

Pay Unit

Lump Sum

BRIDGE APPROACH SLABS:**SPECIAL****1.0 DESCRIPTION**

Bridge approach slabs shall be constructed in accordance with Section 422 of the Standard Specifications for Roads and Structures.

2.0 MEASUREMENT AND PAYMENT

Bridge Approach Slabs at Bridge #___ will be paid for at the contract lump sum price.

Payment will be made under:

Pay Item

Bridge Approach Slabs at Bridge #___

Pay Unit

Lump Sum

GUARDRAIL ANCHOR UNITS, TYPE 350:

(4-20-04) (Rev. 8-16-11)

862

SP8 R65

Description

Furnish and install guardrail anchor units in accordance with the details in the plans, the applicable requirements of Section 862 of the *2012 Standard Specifications*, and at locations shown in the plans.

Materials

The Contractor may at his option, furnish any one of the guardrail anchor units or approved equal.

Guardrail anchor unit (ET-Plus) as manufactured by:

Trinity Industries, Inc.
2525 N. Stemmons Freeway
Dallas, Texas 75207
Telephone: 800-644-7976

The guardrail anchor unit (SKT 350) as manufactured by:

Road Systems, Inc.
3616 Old Howard County Airport
Big Spring, Texas 79720
Telephone: 915-263-2435

Prior to installation the Contractor shall submit to the Engineer:

- (A) FHWA acceptance letter for each guardrail anchor unit certifying it meets the requirements of NCHRP Report 350, Test Level 3, in accordance with Article 106-2 of the *2012 Standard Specifications*.

- (B) Certified working drawings and assembling instructions from the manufacturer for each guardrail anchor unit in accordance with Article 105-2 of the *2012 Standard Specifications*.

No modifications shall be made to the guardrail anchor unit without the express written permission from the manufacturer. Perform installation in accordance with the details in the plans, and details and assembling instructions furnished by the manufacturer.

Construction Methods

Guardrail end delineation is required on all approach and trailing end sections for both temporary and permanent installations. Guardrail end delineation consists of yellow reflective sheeting applied to the entire end section of the guardrail in accordance with Article 1088-3 of the *2012 Standard Specifications* and is incidental to the cost of the guardrail anchor unit.

Measurement and Payment

Measurement and payment will be made in accordance with Article 862-6 of the *2012 Standard Specifications*.

Payment will be made under:

Pay Item	Pay Unit
Guardrail Anchor Units, Type 350	Each

UNDER STRUCTURE WORK PLATFORM

(12-5-12)

Prior to any painting operations on the structure, provide details for a sufficiently sized under structure work platform which will provide access for cleaning and painting the bridge. The Contractor shall determine the required capacity of the platform, but the capacity shall not be less than that required by Federal or State regulations. Design steel members to meet the requirements of the American Institute of Steel Construction Manual. Design timber members in accordance with the "National Design Specification for Stress-Grade Lumber and Its Fastenings" of the National Forest Products Association. The platform shall be constructed of materials capable of withstanding damage from any of the work required on this project and shall be fireproof. Submit the platform design and plans for review and approval. The design and plans shall be sealed and signed by a North Carolina registered Professional Engineer. Do not install the platform until the design and plans are approved. Drilling holes in the superstructure for the purpose of attaching the platform is prohibited. Upon completion of work, remove all anchorages in the substructure and repair the substructure at no additional cost to the Department.

The platform shall be cleaned after each work day to prevent materials from falling or washing below.

Under Structure Work Platform at Bridge #65 will be paid at the lump sum contract price and will be full compensation for the design, materials, installation, maintenance, and removal of the platform

Payment will be made under:

Pay Item	Pay Unit
Under Structure Work Platform at Bridge #65	Lump Sum