

0302DEL\_P12

09/08/99

REVISIONS

TIP PROJECT: U-3459

CONTRACT: C203127

10/3/2012 R:\Rail-Roadway\Proj\Klumac\_RailRdy\_Title Sheet.dgn Florence & Hutcheson, Inc.

See Sheet 1-A For Index of Sheets

STATE OF NORTH CAROLINA  
DIVISION OF HIGHWAYS

# ROWAN COUNTY

LOCATION: SALISBURY - SR 2541 (KLUMAC ROAD) AT THE  
NORTH CAROLINA RAILROAD

TYPE OF WORK: GRADING, PAVING, DRAINAGE, SIGNING, SIGNALS, STRUCTURE,  
TRACKBED AND WALLS



STATE	STATE PROJECT REFERENCE NO.	SHEET NO.	TOTAL SHEETS
N.C.	U-3459	1	1
STATE PROJ. NO.	P.A. PROJ. NO.	DESCRIPTION	
34951.1.1	STP-2541(4)	P.E.	
53500.1.STR04T3		P.E.	
43219.2.STR1U3459		R/W	
53500.3.STR01T4		UTILITIES	
53500.3.STR01T4		CONSTRUCTION	

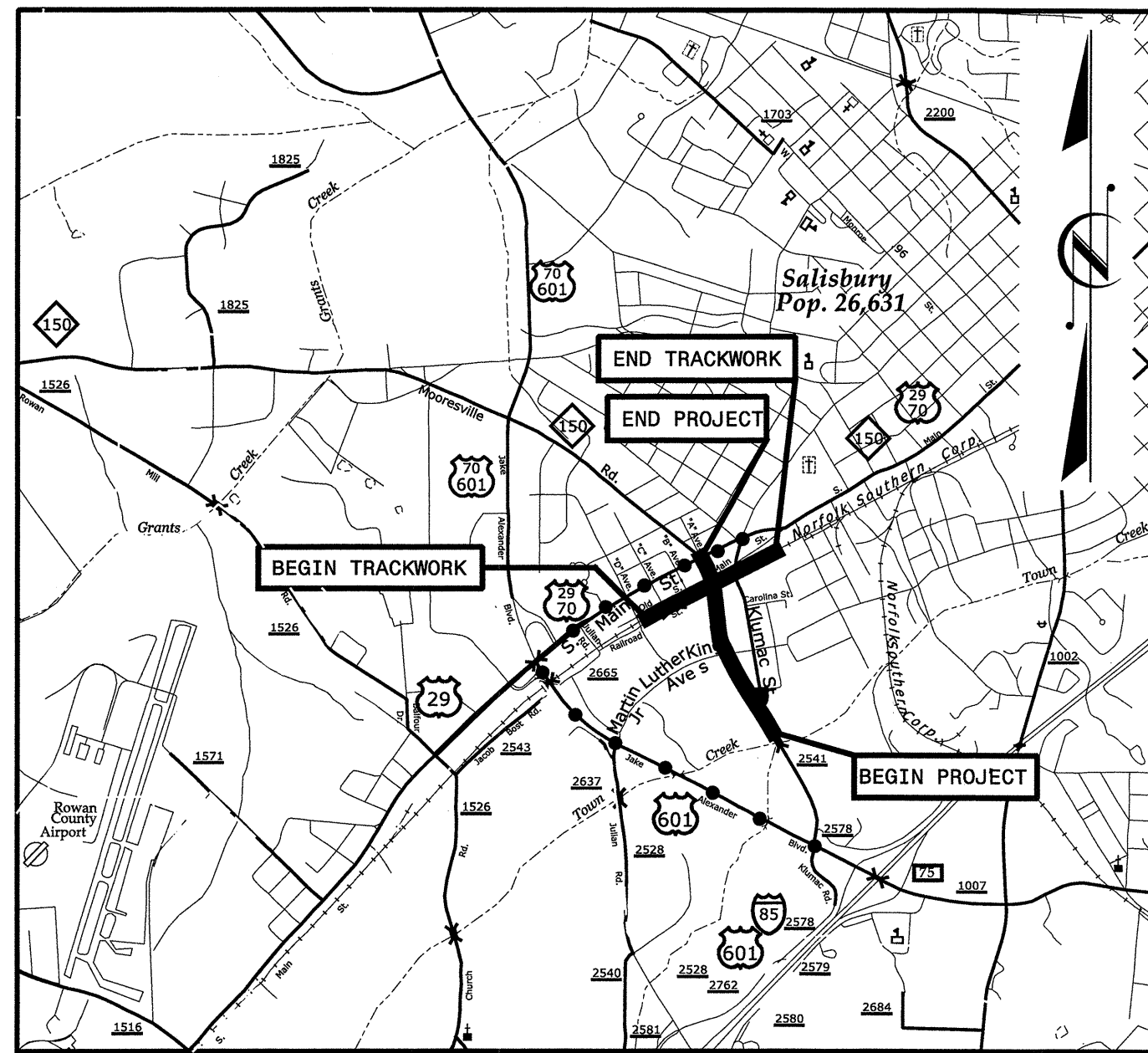

VICINITY MAP

● — ● — ● OFFSITE DETOUR

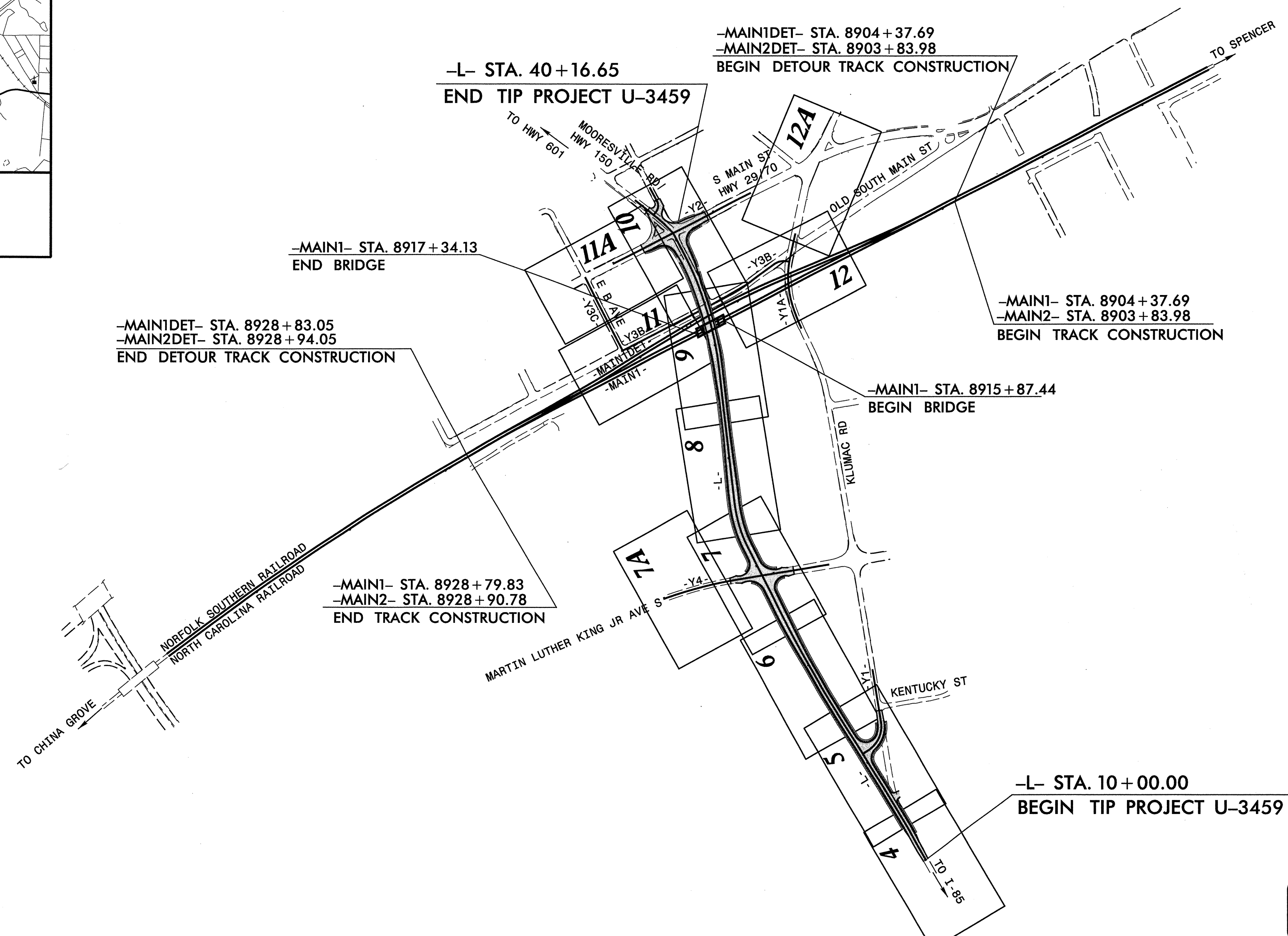

NAD 83/  
NSRS 2007

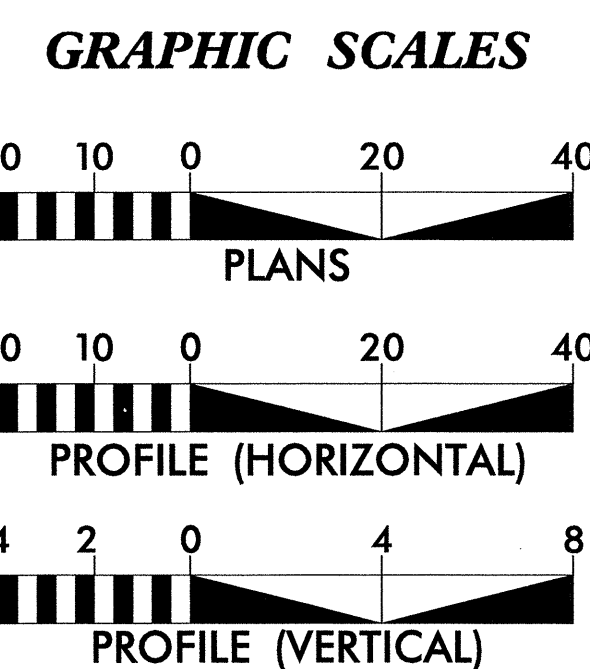
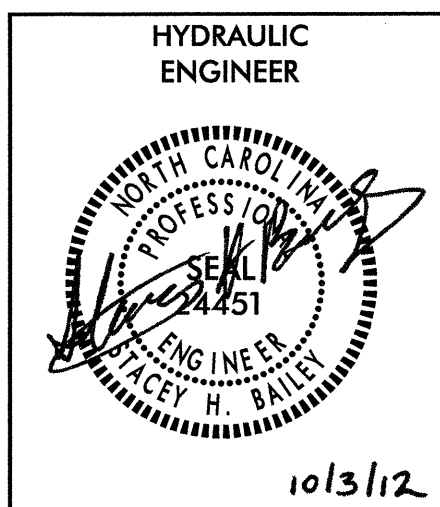

**DESIGN DATA**

ADT 2010 =	7,000
ADT 2035 =	10,200
DHV =	10 %
D =	65 %
T =	7 %
V =	40 MPH
* TTST =	2% DUAL 5%
FUNC CLASS =	URBAN COLLECTOR
REGIONAL TIER	

ROADWAY DESIGN ENGINEER

NORTH CAROLINA DEPARTMENT OF TRANSPORTATION  
**RAIL DIVISION**  
2012 STANDARD SPECIFICATIONS

RIGHT OF WAY DATE: **OCTOBER 31, 2011**

LEONARD FLETCHER, PE  
PROJECT ENGINEER

LETTING DATE: **DECEMBER 18, 2012**

JIMMY L. TERRY, PE  
PROJECT DESIGN ENGINEER

PROJECT **U-3459 - KLUMAC ROAD**

TITLE **TITLE SHEET**

LOCATION **KLUMAC ROAD (SR 2541) IN SALISBURY, NC**

RAILROAD **NORTH CAROLINA RAILROAD/NORFOLK SOUTHERN**

MILE POST **MP 335.2**

PLANS PREPARED BY: **TGS ENGINEERS**

975 WALNUT STREET  
CARY, NC 27511  
PH (919) 319-8850  
CORP. LICENSE NO. L-C-0275

VAL SEC

Florence & Hutcheson  
An ICF Company  
5121 Raleigh Way, Suite 100 Raleigh, NC 27607  
NC License No. P-0228

PLANS PREPARED FOR: **NCDOT RAIL DIVISION**  
**SANDRA A. STEPNEY, PE**  
SENIOR PROJECT ENGINEER

SHEET 1 OF

0302DEL\_P12

1/22/02

STATE OF NORTH CAROLINA DIVISION OF HIGHWAYS

EFF. 01-17-12

U-3459 - INDEX OF SHEETS

2012 ROADWAY ENGLISH STANDARD DRAWINGS

The following Roadway Standards as appear in "Roadway Standard Drawings" Highway Design Branch - N. C. Department of Transportation - Raleigh, N. C., Dated January, 2006 are applicable to this project and by reference hereby are considered a part of these plans:

Table with 2 columns: SHEET NUMBER and SHEET. Lists sheets 1 through W-7 and their corresponding titles.

Table with 2 columns: STD. NO. and TITLE. Lists standards from 200.03 to 876.04.

GENERAL NOTES:

2012 SPECIFICATIONS EFFECTIVE: 01-17-12 REVISED: 11-01-11

GRADING AND SURFACING OR RESURFACING AND WIDENING:

THE GRADE LINES SHOWN DENOTE THE FINISHED ELEVATION OF THE PROPOSED SURFACING AT GRADE POINTS SHOWN ON THE TYPICAL SECTIONS.

CLEARING:

CLEARING ON THIS PROJECT SHALL BE PERFORMED TO THE LIMITS ESTABLISHED BY METHOD III.

SUPERELEVATION:

ALL CURVES ON THIS PROJECT SHALL BE SUPERELEVATED IN ACCORDANCE WITH STD. NO. 225.04 USING THE RATE OF SUPERELEVATION AND RUNOFF SHOWN ON THE PLANS.

SIDE ROADS:

THE CONTRACTOR WILL BE REQUIRED TO DO ALL NECESSARY WORK TO PROVIDE SUITABLE CONNECTIONS WITH ALL ROADS, STREETS, AND DRIVES ENTERING THIS PROJECT.

UNDERDRAINS:

UNDERDRAINS SHALL BE CONSTRUCTED IN ACCORDANCE WITH STD. NO. 815.03 AT LOCATIONS DIRECTED BY THE ENGINEER.

DRIVEWAYS:

DRIVEWAYS SHALL BE CONSTRUCTED IN ACCORDANCE WITH STD. 848.02 USING A 3' RADIUS OR RADIUS AS SHOWN ON THE PLANS.

STREET TURNOUT:

STREET RETURNS SHALL BE CONSTRUCTED IN ACCORDANCE WITH STD. NO. 848.04 USING THE RADIUS NOTED ON PLANS.

GUARDRAIL:

THE GUARDRAIL LOCATIONS SHOWN ON THE PLANS MAY BE ADJUSTED DURING CONSTRUCTION AS DIRECTED BY THE ENGINEER.

TEMPORARY SHORING:

SHORING REQUIRED FOR THE MAINTENANCE OF TRAFFIC WILL BE PAID FOR AS "EXTRA WORK" IN ACCORDANCE WITH SECTION 104-7.

END BENTS:

THE ENGINEER SHALL CHECK THE STRUCTURE END BENT PLANS, DETAILS, AND CROSS-SECTION PRIOR TO SETTING OF THE SLOPE STAKES FOR THE EMBANKMENT OR EXCAVATION APPROACHING A BRIDGE.

UTILITIES:

UTILITY OWNERS ON THIS PROJECT ARE Duke Energy Transmission, Duke Energy Distribution, Duke Net-Fiber Optic, AT&T, Windstream Communications, Fibrant (City of Salisbury, Piedmont Natural Gas, Time Warner Cable and Salisbury-Rowan Utilities).

ANY RELOCATION OF EXISTING UTILITIES WILL BE ACCOMPLISHED BY OTHERS, EXCEPT AS SHOWN ON THE PLANS.

RIGHT-OF-WAY MARKERS:

ALL RIGHT-OF-WAY MARKERS ON THIS PROJECT SHALL BE PLACED BY CONTRACT.

CURB RAMPS:

CURB RAMPS ARE SHOWN ON THE PLANS AT APPROXIMATE LOCATIONS. CONSTRUCT ALL CURB RAMPS ACCORDANCE WITH STD. 848.05 AND 848.06 AND WITH THE DETAILS IN THE PLANS.

R:\Rail-Roadway\Proj\KLU\KLU\Rail\_Rdy\_summar\_shts.dgn

Florence & Hutcheson 3/1/2012

Table with 4 columns: NO., BY, DATE, REVISION. Contains revision history.

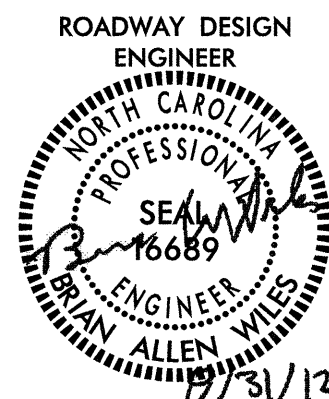

North Carolina Department of Transportation RAIL DIVISION logo and contact information for Engineering & Safety Branch.















Project information table including Project (U-3459 - KLUMAC ROAD), Title (SHEET 1-A), Location (KLUMAC ROAD (SR 2541) IN SALISBURY, NC), and Date (OCT. 2011).

Note: Not to Scale











\*S.U.E. = Subsurface Utility Engineering

# CONVENTIONAL PLAN SHEET SYMBOLS











## BOUNDARIES AND PROPERTY:

State Line	_____
County Line	_____
Township Line	_____
City Line	_____
Reservation Line	_____
Property Line	_____
Existing Iron Pin	_____ 
Property Corner	_____ 
Property Monument	_____ 
Parcel/Sequence Number	_____ 
Existing Fence Line	_____ 
Proposed Woven Wire Fence	_____ 
Proposed Chain Link Fence	_____ 
Proposed Barbed Wire Fence	_____ 
Existing Wetland Boundary	_____ 
Proposed Wetland Boundary	_____ 
Existing Endangered Animal Boundary	_____ 
Existing Endangered Plant Boundary	_____ 
Known Soil Contamination: Boundary or Site	_____ 
Potential Soil Contamination: Boundary or Site	_____ 





## BUILDINGS AND OTHER CULTURE:

Gas Pump Vent or U/G Tank Cap	_____ 
Sign	_____ 
Well	_____ 
Small Mine	_____ 
Foundation	_____ 
Area Outline	_____ 
Cemetery	_____ 
Building	_____ 
School	_____ 
Church	_____ 
Dam	_____ 



## HYDROLOGY:

Stream or Body of Water	_____
Hydro, Pool or Reservoir	_____ 
Jurisdictional Stream	_____ 
Buffer Zone 1	_____ 
Buffer Zone 2	_____ 
Flow Arrow	_____ 
Disappearing Stream	_____ 
Spring	_____ 
Wetland	_____ 
Proposed Lateral, Tail, Head Ditch	_____ 
False Sump	_____ 



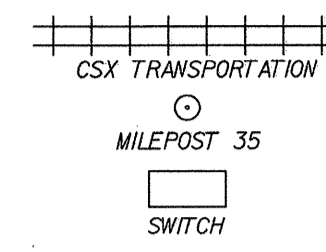













## RAILROADS:

Standard Gauge	_____ 
RR Signal Milepost	_____ 
Switch	_____ 
RR Abandoned	_____ 
RR Dismantled	_____ 













Orchard	_____ 
Vineyard	_____ 





## RIGHT OF WAY:

Baseline Control Point	_____ 
Existing Right of Way Marker	_____ 
Existing Right of Way Line	_____ 
Proposed Right of Way Line	_____ 
Proposed Right of Way Line with Iron Pin and Cap Marker	_____ 
Proposed Right of Way Line with Concrete or Granite Marker	_____ 
Existing Control of Access	_____ 
Proposed Control of Access	_____ 
Existing Easement Line	_____ 
Proposed Temporary Construction Easement	_____ 
Proposed Temporary Drainage Easement	_____ 
Proposed Permanent Drainage Easement	_____ 
Proposed Permanent Drainage / Utility Easement	_____ 
Proposed Permanent Utility Easement	_____ 
Proposed Temporary Utility Easement	_____ 
Proposed Aerial Utility Easement	_____ 









## ROADS AND RELATED FEATURES:

Existing Edge of Pavement	_____ 
Existing Curb	_____ 
Proposed Slope Stakes Cut	_____ 
Proposed Slope Stakes Fill	_____ 
Proposed Curb Ramp	_____ 
Curb Cut Future Ramp	_____ 
Existing Metal Guardrail	_____ 
Proposed Guardrail	_____ 
Existing Cable Guiderail	_____ 
Proposed Cable Guiderail	_____ 
Equality Symbol	_____ 











## VEGETATION:

Pavement Removal	_____ 
Single Tree	_____ 
Single Shrub	_____ 
Hedge	_____ 
Woods Line	_____ 













## EXISTING STRUCTURES:

MAJOR: Bridge, Tunnel or Box Culvert	_____ 
MAJOR: Bridge Wing Wall, Head Wall and End Wall	_____ 
MINOR: Head and End Wall	_____ 
MINOR: Pipe Culvert	_____ 
MINOR: Footbridge	_____ 
MINOR: Drainage Box: Catch Basin, DI or JB	_____ 
MINOR: Paved Ditch Gutter	_____ 
MINOR: Storm Sewer Manhole	_____ 
MINOR: Storm Sewer	_____ 







## UTILITIES:

POWER: Existing Power Pole	_____ 
POWER: Proposed Power Pole	_____ 
POWER: Existing Joint Use Pole	_____ 
POWER: Proposed Joint Use Pole	_____ 
POWER: Power Manhole	_____ 
POWER: Power Line Tower	_____ 
POWER: Power Transformer	_____ 
POWER: U/G Power Cable Hand Hole	_____ 
POWER: H-Frame Pole	_____ 
POWER: Recorded U/G Power Line	_____ 
POWER: Designated U/G Power Line (S.U.E.*)	_____ 









## TELEPHONE:

TELEPHONE: Existing Telephone Pole	_____ 
TELEPHONE: Proposed Telephone Pole	_____ 
TELEPHONE: Telephone Manhole	_____ 
TELEPHONE: Telephone Booth	_____ 
TELEPHONE: Telephone Pedestal	_____ 
TELEPHONE: Telephone Cell Tower	_____ 
TELEPHONE: U/G Telephone Cable Hand Hole	_____ 
TELEPHONE: Recorded U/G Telephone Cable	_____ 
TELEPHONE: Designated U/G Telephone Cable (S.U.E.*)	_____ 
TELEPHONE: Recorded U/G Telephone Conduit	_____ 
TELEPHONE: Designated U/G Telephone Conduit (S.U.E.*)	_____ 
TELEPHONE: Recorded U/G Fiber Optics Cable	_____ 
TELEPHONE: Designated U/G Fiber Optics Cable (S.U.E.*)	_____ 





## WATER:

Water Manhole	_____ 
Water Meter	_____ 
Water Valve	_____ 
Water Hydrant	_____ 
Recorded U/G Water Line	_____ 
Designated U/G Water Line (S.U.E.*)	_____ 
Above Ground Water Line	_____ 







## TV:

TV: TV Satellite Dish	_____ 
TV: TV Pedestal	_____ 
TV: TV Tower	_____ 
TV: U/G TV Cable Hand Hole	_____ 
TV: Recorded U/G TV Cable	_____ 
TV: Designated U/G TV Cable (S.U.E.*)	_____ 
TV: Recorded U/G Fiber Optic Cable	_____ 
TV: Designated U/G Fiber Optic Cable (S.U.E.*)	_____ 













## GAS:

GAS: Gas Valve	_____ 
GAS: Gas Meter	_____ 
GAS: Recorded U/G Gas Line	_____ 
GAS: Designated U/G Gas Line (S.U.E.*)	_____ 
GAS: Above Ground Gas Line	_____ 

## SANITARY SEWER:

SANITARY SEWER: Sanitary Sewer Manhole	_____ 
SANITARY SEWER: Sanitary Sewer Cleanout	_____ 
SANITARY SEWER: U/G Sanitary Sewer Line	_____ 
SANITARY SEWER: Above Ground Sanitary Sewer	_____ 
SANITARY SEWER: Recorded SS Forced Main Line	_____ 
SANITARY SEWER: Designated SS Forced Main Line (S.U.E.*)	_____ 

## MISCELLANEOUS:

MISCELLANEOUS: Utility Pole	_____ 
MISCELLANEOUS: Utility Pole with Base	_____ 
MISCELLANEOUS: Utility Located Object	_____ 
MISCELLANEOUS: Utility Traffic Signal Box	_____ 
MISCELLANEOUS: Utility Unknown U/G Line	_____ 
MISCELLANEOUS: U/G Tank; Water, Gas, Oil	_____ 
MISCELLANEOUS: Underground Storage Tank, Approx. Loc.	_____ 
MISCELLANEOUS: A/G Tank; Water, Gas, Oil	_____ 
MISCELLANEOUS: Geoenvironmental Boring	_____ 
MISCELLANEOUS: U/G Test Hole (S.U.E.*)	_____ 
MISCELLANEOUS: Abandoned According to Utility Records	_____ 
MISCELLANEOUS: End of Information	_____ 

0302DEL\_P12 04/16/11

# SURVEY CONTROL SHEET U-3459

0302DEL\_P12

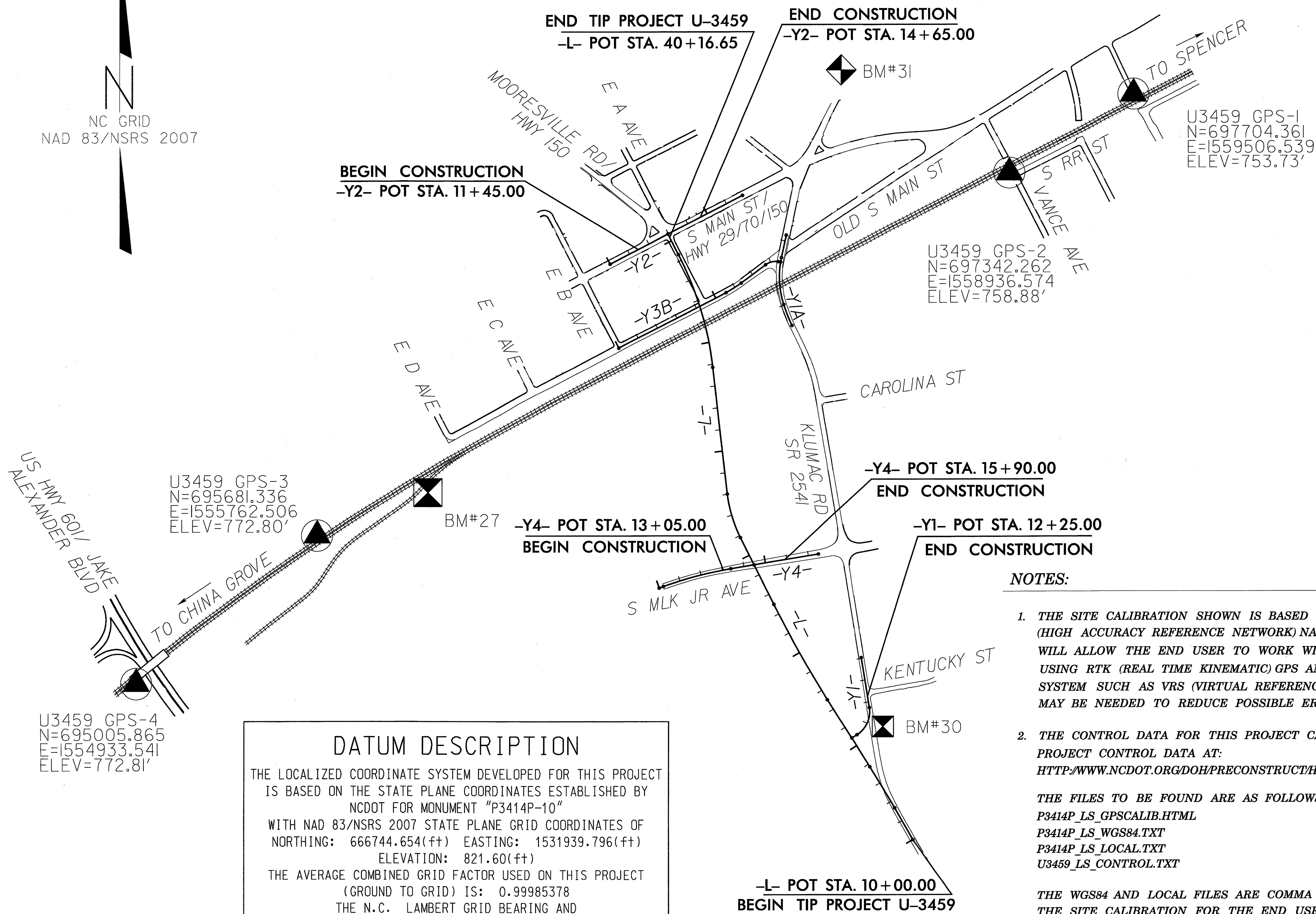
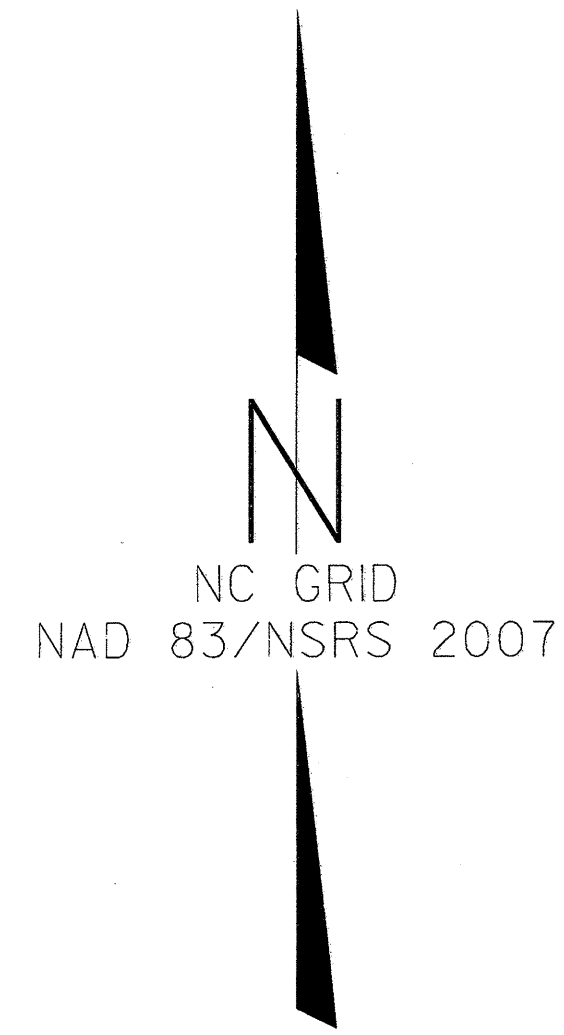

**DATUM DESCRIPTION**

THE LOCALIZED COORDINATE SYSTEM DEVELOPED FOR THIS PROJECT IS BASED ON THE STATE PLANE COORDINATES ESTABLISHED BY NCDOT FOR MONUMENT "P3414P-10" WITH NAD 83/NSRS 2007 STATE PLANE GRID COORDINATES OF NORTHING: 666744.654(ft) EASTING: 1531939.796(ft) ELEVATION: 821.60(ft)

THE AVERAGE COMBINED GRID FACTOR USED ON THIS PROJECT (GROUND TO GRID) IS: 0.99985378

THE N.C. LAMBERT GRID BEARING AND LOCALIZED HORIZONTAL GROUND DISTANCE FROM "P3414P-10" TO -L- STATION 10+00.0 IS N 43°57'00.8" E 38264.72'

ALL LINEAR DIMENSIONS ARE LOCALIZED HORIZONTAL DISTANCES VERTICAL DATUM USED IS NAVD 88

**NOTES:**

1. THE SITE CALIBRATION SHOWN IS BASED UPON A NETWORK TIED TO THE HARN (HIGH ACCURACY REFERENCE NETWORK) NAD 83/NSRS 2007 ADJUSTMENT. THIS CALIBRATION WILL ALLOW THE END USER TO WORK WITHIN THE SAME COORDINATE SYSTEM WHEN USING RTK (REAL TIME KINEMATIC) GPS AND A LOCAL BASE STATION. IF ANOTHER SYSTEM SUCH AS VRS (VIRTUAL REFERENCE STATION) IS USED, ADDITIONAL FIELD TIES MAY BE NEEDED TO REDUCE POSSIBLE ERRORS, OR BIASES.
2. THE CONTROL DATA FOR THIS PROJECT CAN BE FOUND ELECTRONICALLY BY SELECTING PROJECT CONTROL DATA AT:  
[HTTP://WWW.NCDOT.ORG/DOH/PRECONSTRUCT/HIGHWAY/LOCATION/PROJECT/](http://www.ncdot.org/doh/preconstruct/highway/location/project/)

THE FILES TO BE FOUND ARE AS FOLLOWS:  
P3414P\_LS\_GPSCALIB.HTML  
P3414P\_LS\_WGS84.TXT  
P3414P\_LS\_LOCAL.TXT  
U3459\_LS\_CONTROL.TXT

THE WGS84 AND LOCAL FILES ARE COMMA DELIMITED AND CAN BE USED TO REPRODUCE THE SITE CALIBRATION FOR THE END USER'S GPS EQUIPMENT. IF FURTHER INFORMATION IS NEEDED, PLEASE CONTACT THE LOCATION AND SURVEYS UNIT.

INDICATES GEODETIC CONTROL MONUMENTS USED OR SET FOR HORIZONTAL PROJECT CONTROL BY THE NCDOT LOCATION AND SURVEYS UNIT.  
PROJECT CONTROL ESTABLISHED USING GLOBAL POSITIONING SYSTEM NETWORK ESTABLISHED FROM EXISTING HARN MONUMENTATION  
SEE GPS CALIBRATION SHEET FOR HORIZONTAL AND VERTICAL COORDINATE VALUES.

NOTE: DRAWING NOT TO SCALE

7/17/2012  
R:\Rail-Roadway\_Proj\U3459\_Ls\_1c.dgn  
Location & Surveys Unit

# SURVEY CONTROL SHEET U-3459

0302DEL\_P12

## GPS Calibration Report

Project : P3414PZ  
 TIP Number P3414P  
 User name tbovender Date & Time 6:15:58 AM 3/30/2009  
 Coordinate System US State Plane 1983(at ground) Zone North Carolina 3200  
 Horizontal Datum NAD 1983 (Conus)  
 Vertical Datum NAVD 88 Geoid Model G03NC  
 Coordinate Units US survey feet  
 Distance Units US survey feet  
 Height Units US survey feet

LOCAL SITE INFORMATION  
 Localized around  
 Latitude 35°34'18.46142"N  
 Longitude 80°34'26.64222"W  
 Site Scale Factor 1.0001462406  
 Height 719.931sft

The North Carolina Department of Transportation uses a Localized Coordinate System which is very similar to North Carolina Zone 3200 from which it is derived. Please take care in utilizing these coordinates to eliminate confusion of the two systems. This file is to aid in the use of Real Time Kinematic (RTK) GPS during construction layout.

### Updated Default Projection (Transverse Mercator) Definition

Updated default projection not requested

### Horizontal Adjustment Parameters

Northing coordinate of rotation center 667263.504sft  
 Easting coordinate of rotation center 1532682.097sft  
 Rotation about the center point 0°00'00"  
 Translation north 0.075sft  
 Translation east 0.003sft  
 Scale factor 0.99999875

### Vertical Adjustment Parameters

Northing coordinate of origin point 691593.681sft  
 Easting coordinate of origin point 1551534.529sft  
 Vertical separation at origin 0.061sft  
 Slope north -0.708ppm  
 Slope east 0.902ppm

### Geoid Model Definition

G03NC

### Residual Differences Between GPS (WGS84) And Local Coordinates

#### Summary

	Maximum error	Root Mean Square error	Point
Horizontal	0.003sft	0.001	1_GPS
Vertical	0.001sft	0.000	9_GPS
Three-dimensional	0.003sft	0.001	1_GPS

### Datum Transformation Parameters

Datum Transformation computation not requested

Point P3414P GPS-1  
 Latitude 35°38'27.18153"N  
 Longitude 80°30'34.06069"W  
 Height 669.991sft

Northing 691593.681sft  
 Easting 1551534.529sft  
 Elevation 772.105sft  
 Horz error 0.003sft  
 Vert error 0.000sft  
 3D error 0.003sft

Point 1  
 Northing 691593.682sft  
 Easting 1551534.532sft  
 Elevation 772.105sft  
 Utilized Horz and Vert  
 Quality Adjusted quality

Point P3414P GPS -2  
 Latitude 35°38'15.07971"N  
 Longitude 80°30'46.16340"W  
 Height 677.436sft

Northing 690385.298sft  
 Easting 1550516.988sft  
 Elevation 779.520sft  
 Horz error 0.003sft  
 Vert error 0.000sft  
 3D error 0.003sft

Point 2  
 Northing 690385.299sft  
 Easting 1550516.991sft  
 Elevation 779.519sft  
 Utilized Horz and Vert  
 Quality Adjusted quality

Point P3414P GPS-3  
 Latitude 35°37'18.38221"N  
 Longitude 80°31'47.01758"W  
 Height 690.082sft

Northing 684729.738sft  
 Easting 1545405.862sft  
 Elevation 792.047sft  
 Horz error 0.001sft  
 Vert error 0.000sft  
 3D error 0.001sft

Point 3  
 Northing 684729.738sft  
 Easting 1545405.863sft  
 Elevation 792.047sft  
 Utilized Horz and Vert  
 Quality Adjusted quality

Point P3414P GPS-4  
 Latitude 35°37'10.70693"N  
 Longitude 80°31'52.55258"W  
 Height 694.583sft

Northing 683960.759sft  
 Easting 1544936.955sft  
 Elevation 796.530sft  
 Horz error 0.000sft  
 Vert error 0.000sft  
 3D error 0.000sft

Point 4  
 Northing 683960.758sft  
 Easting 1544936.955sft  
 Elevation 796.530sft  
 Utilized Horz and Vert  
 Quality Adjusted quality

## DATUM DESCRIPTION

THE LOCALIZED COORDINATE SYSTEM DEVELOPED FOR THIS PROJECT IS BASED ON THE STATE PLANE COORDINATES ESTABLISHED BY NCDOT FOR MONUMENT "P3414P-10" WITH NAD 83/NSRS 2007 STATE PLANE GRID COORDINATES OF NORTHING: 666744.654(++) EASTING: 1531939.796(++) ELEVATION: 821.60(++) THE AVERAGE COMBINED GRID FACTOR USED ON THIS PROJECT (GROUND TO GRID) IS: 0.99985378 THE N.C. LAMBERT GRID BEARING AND LOCALIZED HORIZONTAL GROUND DISTANCE FROM "P3414P-10" TO -L- STATION 10+00.0 IS N 43°57'00.8" E 38264.72' ALL LINEAR DIMENSIONS ARE LOCALIZED HORIZONTAL DISTANCES VERTICAL DATUM USED IS NAVD 88

### NOTES:

1. THE SITE CALIBRATION SHOWN IS BASED UPON A NETWORK TIED TO THE HARN (HIGH ACCURACY REFERENCE NETWORK) NAD 83/NSRS 2007 ADJUSTMENT. THIS CALIBRATION WILL ALLOW THE END USER TO WORK WITHIN THE SAME COORDINATE SYSTEM WHEN USING RTK (REAL TIME KINEMATIC) GPS AND A LOCAL BASE STATION. IF ANOTHER SYSTEM SUCH AS VRS (VIRTUAL REFERENCE STATION) IS USED, ADDITIONAL FIELD TIES MAY BE NEEDED TO REDUCE POSSIBLE ERRORS, OR BIASES.

2. THE CONTROL DATA FOR THIS PROJECT CAN BE FOUND ELECTRONICALLY BY SELECTING PROJECT CONTROL DATA AT:  
[HTTP://WWW.NCDOT.ORG/DOH/PRECONSTRUCT/HIGHWAY/LOCATION/PROJECT/](http://www.ncdot.org/doh/preconstruct/highway/location/project/)

THE FILES TO BE FOUND ARE AS FOLLOWS:

- P3414P\_LS\_GPSCALIB.HTML
- P3414P\_LS\_WGS84.TXT
- P3414P\_LS\_LOCAL.TXT
- U3459\_LS\_CONTROL.TXT

THE WGS84 AND LOCAL FILES ARE COMMA DELIMITED AND CAN BE USED TO REPRODUCE THE SITE CALIBRATION FOR THE END USER'S GPS EQUIPMENT. IF FURTHER INFORMATION IS NEEDED, PLEASE CONTACT THE LOCATION AND SURVEYS UNIT.



INDICATES GEODETIC CONTROL MONUMENTS USED OR SET FOR HORIZONTAL PROJECT CONTROL BY THE NCDOT LOCATION AND SURVEYS UNIT.

PROJECT CONTROL ESTABLISHED USING GLOBAL POSITIONING SYSTEM NETWORK ESTABLISHED FROM EXISTING HARN MONUMENTATION

SEE GPS CALIBRATION SHEET FOR HORIZONTAL AND VERTICAL COORDINATE VALUES.

NOTE: DRAWING NOT TO SCALE

1/17/2012  
 P:\Rail-Roadway\Proj\U3459\_Ls\_Id.dgn  
 User: tbovender

# SURVEY CONTROL SHEET U-3459

PROJECT REFERENCE NO. U-3459	SHEET NO. 1E
Location and Surveys	

0302DEL\_P12

BL	POINT	DESC.	NORTH	EAST	ELEVATION	L STATION	OFFSET
1		U3459 GPS-1	697704.3610	1559506.5390	753.73	38+05.29	2203.81 RT
2		U3459 GPS-2	697342.2620	1558936.5740	758.88	37+48.45	1540.64 RT
5		BL-5	696791.1180	1557864.1240	763.84	36+33.09	348.71 RT
6		BL-6	696247.3990	1556689.6710	767.69	32+84.18	905.45 LT
3		U3459 GPS-3	695681.3360	1555762.5060	772.80	28+28.67	1891.63 LT
4		U3459 GPS-4	695005.8650	1554933.5410	772.81	27+05.41	2836.91 LT
BY1	POINT	DESC.	NORTH	EAST	ELEVATION	L STATION	OFFSET
9		BY1-9	694193.6620	1558536.6120	712.96	OUTSIDE PROJECT LIMITS	
10		BY1-10	694642.5920	1558322.3180	717.99	13+88.79	28.03 RT
11		BY1-11	695257.1800	1558268.9300	738.66	19+48.35	308.98 RT
12		BY1-12	695659.6920	1558138.7600	755.19	23+85.16	382.27 RT
13		BY1-13	696365.0410	1558068.1450	760.92	32+42.29	477.40 RT
14		BY1-14	697427.7600	1557981.0580	760.29	OUTSIDE PROJECT LIMITS	
15		BY1-15	697763.0080	1558203.9790	764.97	OUTSIDE PROJECT LIMITS	
BY2	POINT	DESC.	NORTH	EAST	ELEVATION	L STATION	OFFSET
17		BY2-17	697481.3560	1558600.2380	753.59	38+82.07	1285.07 RT
18		BY2-18	697496.2760	1558207.9510	763.03	OUTSIDE PROJECT LIMITS	
19		BY2-19	697239.6030	1557650.8630	752.94	OUTSIDE PROJECT LIMITS	
20		BY2-20	697045.9880	1557412.6940	743.23	40+00.33	28.87 RT
21		BY2-21	696788.1460	1556791.0040	759.45	OUTSIDE PROJECT LIMITS	
BY3	POINT	DESC.	NORTH	EAST	ELEVATION	L STATION	OFFSET
22		BY3-22	697189.5790	1558243.2940	761.66	38+11.92	839.77 RT
23		BY3-23	697058.0700	1557970.7690	759.20	38+00.64	537.62 RT
24		BY3-24	696736.2810	1557568.0970	753.45	36+61.20	49.33 RT
25		BY3-25	696520.6560	1557163.3440	760.66	35+42.62	397.50 LT
26		BY3-26	696094.2478	1556368.8579	770.46	31+69.00	1241.76 LT
BY4	POINT	DESC.	NORTH	EAST	ELEVATION	L STATION	OFFSET
12		BY1-12	695659.6920	1558138.7600	755.19	23+85.16	382.27 RT
27		BY4-27	695436.3369	1557369.4114	745.77	25+31.74	405.32 LT

BENCHMARKS (NAVD 88)  
 \*\*\*\*\*  
 BM27 ELEVATION = 767.94'  
 N 695879 E 1556272  
 L STATION 29+66.00 1363' LEFT  
 CHISELED SQUARE IN BROKEN OFF CONCRETE  
 POST +/-50' SW OF RR HANDSWITCH ON SPUR  
 LINE. +/-30' SOUTH OF SPUR LINE. ON  
 SOUTH EDGE OF EP.  
 \*\*\*\*\*  
 BM30 ELEVATION = 721.84'  
 N 694810 E 1558359  
 L STATION 15+10.00 149' RIGHT  
 CHISELED SQUARE IN SE CORNER OF CONCRETE  
 PAD FOR WATER UTILITIES. NEAR BLUE METAL  
 BUILDING.  
 \*\*\*\*\*  
 BM31 ELEVATION = 764.92'  
 N 697817 E 1558165  
 BY1-15 TO BM\*31  
 N 36+07'22" W 66.72'  
 CHISELED SQUARE IN SIDEWALK ON SOUTHSIDE  
 OF MAUPIN AVENUE. ACROSS FROM MAUPIN  
 AVENUE PRESBYTERIAN CHURCH  
 \*\*\*\*\*

**NOTES:**

1. THE SITE CALIBRATION SHOWN IS BASED UPON A NETWORK TIED TO THE HARN (HIGH ACCURACY REFERENCE NETWORK) NAD 83/NSRS 2007 ADJUSTMENT. THIS CALIBRATION WILL ALLOW THE END USER TO WORK WITHIN THE SAME COORDINATE SYSTEM WHEN USING RTK (REAL TIME KINEMATIC) GPS AND A LOCAL BASE STATION. IF ANOTHER SYSTEM SUCH AS VRS (VIRTUAL REFERENCE STATION) IS USED, ADDITIONAL FIELD TIES MAY BE NEEDED TO REDUCE POSSIBLE ERRORS, OR BIASES.

2. THE CONTROL DATA FOR THIS PROJECT CAN BE FOUND ELECTRONICALLY BY SELECTING PROJECT CONTROL DATA AT:  
[HTTP://WWW.NCDOT.ORG/DOH/PRECONSTRUCT/HIGHWAY/LOCATIONPROJECT/](http://www.ncdot.org/doh/preconstruct/highway/locationproject/)

THE FILES TO BE FOUND ARE AS FOLLOWS:  
 P3414P\_LS\_GPSLIB.HTML  
 P3414P\_LS\_WGS84.TXT  
 P3414P\_LS\_LOCAL.TXT  
 U3459\_LS\_CONTROL.TXT

THE WGS84 AND LOCAL FILES ARE COMMA DELIMITED AND CAN BE USED TO REPRODUCE THE SITE CALIBRATION FOR THE END USER'S GPS EQUIPMENT. IF FURTHER INFORMATION IS NEEDED, PLEASE CONTACT THE LOCATION AND SURVEYS UNIT.



INDICATES GEODETIC CONTROL MONUMENTS USED OR SET FOR HORIZONTAL PROJECT CONTROL BY THE NCDOT LOCATION AND SURVEYS UNIT.

PROJECT CONTROL ESTABLISHED USING GLOBAL POSITIONING SYSTEM.

NETWORK ESTABLISHED FROM EXISTING HARN MONUMENTATION

SEE GPS CALIBRATION SHEET FOR HORIZONTAL AND VERTICAL COORDINATE VALUES.

**DATUM DESCRIPTION**

THE LOCALIZED COORDINATE SYSTEM DEVELOPED FOR THIS PROJECT IS BASED ON THE STATE PLANE COORDINATES ESTABLISHED BY NCDOT FOR MONUMENT "P3414P-10" WITH NAD 83/NSRS 2007 STATE PLANE GRID COORDINATES OF NORTHING: 666744.654(ft) EASTING: 1531939.796(ft) ELEVATION: 821.60(ft)

THE AVERAGE COMBINED GRID FACTOR USED ON THIS PROJECT (GROUND TO GRID) IS: 0.99985378

THE N.C. LAMBERT GRID BEARING AND LOCALIZED HORIZONTAL GROUND DISTANCE FROM "P3414P-10" TO -L- STATION 10+00.0 IS  
 N 43°57'00.8" E 38264.72'

ALL LINEAR DIMENSIONS ARE LOCALIZED HORIZONTAL DISTANCES  
 VERTICAL DATUM USED IS NAVD 88

NOTE: DRAWING NOT TO SCALE

7/17/2012  
 P:\Rail-Roadway\Pro\U3459\LS\_Leidgn  
 Location and Surveys Unit

**SURVEY CONTROL SHEET U-3459****DESIGN ALIGNMENTS**

PROJECT REFERENCE NO.	SHEET NO.
U-3459	1F
Location and Surveys	

L

TYPE	STATION	NORTH	EAST
POT	10+00.00	694293.0788	1558496.7771
PC	11+66.61	694437.4985	1558413.6942
PT	13+87.04	694626.0783	1558299.6021
PC	17+51.36	694933.5609	1558104.1878
PT	22+49.23	695366.3394	1557858.4891
PC	25+90.87	695671.4694	1557704.8107
PT	28+01.56	695872.2603	1557644.6750
PC	33+86.61	696453.4243	1557577.2956
PT	39+29.76	696970.0420	1557419.4817
POT	40+34.65	697063.1969	1557371.2773

Y1

TYPE	STATION	NORTH	EAST
POT	10+00.00	694756.7158	1558216.5781
PC	10+28.63	694772.0727	1558240.7417
PT	11+74.62	694897.8857	1558297.0322
POT	14+03.73	695123.9520	1558259.7951

Y1A

TYPE	STATION	NORTH	EAST
PC	10+00.00	696643.6652	1557940.5084
PCC	11+04.14	696740.5689	1557902.5374
PT	13+21.62	696955.2937	1557891.6631
POT	14+26.18	697057.5223	1557913.6047

Y2

TYPE	STATION	NORTH	EAST
POT	10+00.00	696926.0808	1557106.5906
POT	16+82.94	697240.2151	1557712.9901

Y3B

TYPE	STATION	NORTH	EAST
POT	10+00.00	696540.2787	1557147.1333
PC	15+53.01	696795.1467	1557637.9156
PT	16+35.19	696838.8305	1557707.4138
PC	17+74.89	696922.6297	1557819.1849
PT	18+35.22	696936.6512	1557876.2043
POT	18+46.96	696934.7678	1557887.7952

Y4

TYPE	STATION	NORTH	EAST
POT	10+00.00	695442.0225	1557333.0570
PC	10+20.61	695448.8724	1557352.4920
PT	13+39.74	695528.5339	1557661.1166
POT	17+46.61	695595.9051	1558062.3676

**DATUM DESCRIPTION**

THE LOCALIZED COORDINATE SYSTEM DEVELOPED FOR THIS PROJECT IS BASED ON THE STATE PLANE COORDINATES ESTABLISHED BY NCDOT FOR MONUMENT "P3414P-10"  
 WITH NAD 83/NSRS 2007 STATE PLANE GRID COORDINATES OF  
 NORTHING: 666744.654(++) EASTING: 1531939.796(++)  
 ELEVATION: 821.60(++)  
 THE AVERAGE COMBINED GRID FACTOR USED ON THIS PROJECT  
 (GROUND TO GRID) IS: 0.99985378  
 THE N.C. LAMBERT GRID BEARING AND  
 LOCALIZED HORIZONTAL GROUND DISTANCE FROM  
 "P3414P-10" TO -L- STATION 10+00.0 IS  
 N 43°57'00.8" E 38264.72'  
 ALL LINEAR DIMENSIONS ARE LOCALIZED HORIZONTAL DISTANCES  
 VERTICAL DATUM USED IS NAVD 88

**NOTES:**

1. THE SITE CALIBRATION SHOWN IS BASED UPON A NETWORK TIED TO THE HARN (HIGH ACCURACY REFERENCE NETWORK) NAD 83/NSRS 2007 ADJUSTMENT. THIS CALIBRATION WILL ALLOW THE END USER TO WORK WITHIN THE SAME COORDINATE SYSTEM WHEN USING RTK (REAL TIME KINEMATIC) GPS AND A LOCAL BASE STATION. IF ANOTHER SYSTEM SUCH AS VRS (VIRTUAL REFERENCE STATION) IS USED, ADDITIONAL FIELD TIES MAY BE NEEDED TO REDUCE POSSIBLE ERRORS, OR BIASES.

2. THE CONTROL DATA FOR THIS PROJECT CAN BE FOUND ELECTRONICALLY BY SELECTING PROJECT CONTROL DATA AT:  
[HTTP://WWW.NCDOT.ORG/DOH/PRECONSTRUCT/HIGHWAY/LOCATION/PROJECT/](http://www.ncdot.org/doh/preconstruct/highway/location/project/)

THE FILES TO BE FOUND ARE AS FOLLOWS:  
 P3414P\_LS\_GPSCALIB.HTML  
 P3414P\_LS\_WGS84.TXT  
 P3414P\_LS\_LOCAL.TXT  
 U3459\_LS\_CONTROL.TXT

THE WGS84 AND LOCAL FILES ARE COMMA DELIMITED AND CAN BE USED TO REPRODUCE THE SITE CALIBRATION FOR THE END USER'S GPS EQUIPMENT. IF FURTHER INFORMATION IS NEEDED, PLEASE CONTACT THE LOCATION AND SURVEYS UNIT.



INDICATES GEODETIC CONTROL MONUMENTS USED OR SET FOR HORIZONTAL PROJECT CONTROL BY THE NCDOT LOCATION AND SURVEYS UNIT.

PROJECT CONTROL ESTABLISHED USING GLOBAL POSITIONING SYSTEM.

NETWORK ESTABLISHED FROM EXISTING HARN MONUMENTATION

SEE GPS CALIBRATION SHEET FOR HORIZONTAL AND VERTICAL COORDINATE VALUES.

NOTE: DRAWING NOT TO SCALE

# SURVEY CONTROL SHEET U-3459

0302DEL\_P12

ROW MARKER CONCRETE MONUMENT

ALIGN	STATION	OFFSET	NORTH	EAST
L	10+37.45	-29.95	694310.6020	1558452.1420
L	10+65.77	30.00	694365.0511	1558489.9824
L	11+10.84	-91.71	694343.4240	1558362.0110
L	11+45.32	30.00	694434.0058	1558450.3137
L	12+00.00	32.21	694482.6293	1558424.7585
L	12+38.20	36.60	694517.9989	1558409.0122
L	12+74.07	-30.00	694514.5454	1558333.4359
L	12+83.65	45.00	694561.6031	1558392.6190
L	13+32.60	58.08	694610.5980	1558377.9067
L	13+56.07	65.93	694634.9099	1558371.9879
L	13+87.04	-30.00	694609.9871	1558274.2827
L	16+21.17	30.00	694839.7719	1558199.3393
L	17+51.36	-30.00	694917.4697	1558078.8684
L	17+51.36	30.00	694949.6521	1558129.5072
L	19+25.00	-30.00	695066.4928	1557987.7532
L	19+25.00	-40.00	695061.4253	1557979.1323
L	19+90.00	30.00	695152.8088	1558007.1009
L	19+90.00	35.00	695155.2863	1558011.4439
L	22+49.23	-40.00	695348.3466	1557822.7643
L	22+49.23	35.00	695382.0830	1557889.7483
L	23+10.00	-40.00	695402.6237	1557795.4277
L	23+10.00	-60.00	695393.6273	1557777.5653
L	23+26.24	-60.00	695408.1340	1557770.2591
L	23+46.24	-40.00	695434.9927	1557779.1251
L	23+56.60	35.00	695477.9781	1557841.4508
L	23+73.34	46.10	695497.9208	1557843.8359
L	23+83.76	-40.00	695468.4979	1557762.2503
L	24+87.34	50.13	695601.5534	1557796.1475
L	25+14.84	35.00	695619.3068	1557770.2708
L	25+42.07	-40.00	695609.8886	1557691.0390
L	25+90.87	35.00	695687.2131	1557736.0699
L	25+90.87	-40.00	695653.4767	1557669.0859
L	26+25.00	-40.00	695686.4365	1557653.6446
L	26+25.00	-35.00	695688.4281	1557658.2308
L	28+01.56	-35.00	695868.2295	1557609.9079
L	28+01.56	35.00	695876.2912	1557679.4421
L	32+60.00	-35.00	696323.6230	1557557.1101
L	33+86.61	35.00	696457.4551	1557612.0627
L	34+10.00	49.00	696483.0352	1557623.0012
L	34+79.52	-41.00	696538.0920	1557523.3880
L	35+04.03	40.81	696577.2688	1557599.2734
L	36+91.76	-50.00	696735.2218	1557464.1881
L	37+22.21	33.00	696790.6881	1557532.9506
L	37+80.00	33.00	696845.9921	1557512.2338
L	38+65.00	-50.00	696890.8611	1557402.6360
L	38+65.00	-41.00	696894.6485	1557410.8003
L	39+03.30	-41.00	696928.2421	1557394.6921
L	39+29.76	45.00	696990.7231	1557459.4478
L	39+50.63	-44.00	696968.3617	1557370.8142
L	39+55.72	45.00	697013.7801	1557447.5166

ROW MARKER CONCRETE MONUMENT

ALIGN	STATION	OFFSET	NORTH	EAST
Y1	11+00.00	-40.00	694841.8502	1558250.8247
Y1	11+74.62	-40.00	694891.3846	1558257.5641
Y1	12+20.22	-40.00	694936.3809	1558250.1524
Y1	12+18.67	29.03	694946.0724	1558318.5175
Y1	11+29.90	40.20	694845.6444	1558335.7751

ROW MARKER CONCRETE MONUMENT

ALIGN	STATION	OFFSET	NORTH	EAST
Y2	13+85.12	35.78	697071.4529	1557465.0068
Y2	12+05.72	35.82	696988.8998	1557305.7281
Y2	11+40.87	31.66	696962.7634	1557246.2366
Y2	11+40.84	24.87	696968.7841	1557243.0903
Y2	14+67.10	30.55	697113.8108	1557535.3933
Y2	14+67.11	25.08	697118.6690	1557532.8870
Y2	13+99.54	-37.88	697143.4990	1557443.9289
Y2	14+69.66	-26.52	697165.6649	1557511.4138
Y2	14+69.65	-28.04	697167.0105	1557510.7102

ROW MARKER CONCRETE MONUMENT

ALIGN	STATION	OFFSET	NORTH	EAST
Y4	13+86.39	53.20	695483.7883	1557715.9293
Y4	13+39.74	-49.39	695577.2404	1557652.9386

ROW MARKER PERMANENT EASEMENT

ALIGN	STATION	OFFSET	NORTH	EAST
L	11+96.09	-60.00	694432.7795	1558347.0897
L	10+90.00	30.00	694386.0504	1558477.9018
L	10+90.00	45.00	694393.5303	1558490.9038
L	11+15.00	45.00	694415.2003	1558478.4373
L	11+15.00	30.00	694407.7204	1558465.4353
L	13+00.00	-70.00	694515.7053	1558285.9221
L	13+45.00	-30.00	694574.6270	1558296.5470
L	20+00.00	-40.00	695126.8845	1557941.3124
L	20+00.00	-70.00	695112.0717	1557915.2244
L	20+70.00	-75.00	695171.6317	1557876.2288
L	20+20.00	35.00	695181.2063	1557996.7608
L	20+20.00	60.00	695193.4632	1558018.5499
L	20+40.00	60.00	695210.7047	1558008.8965
L	20+40.00	35.00	695198.5350	1557987.0585
L	25+30.00	35.00	695632.8465	1557763.4516
L	25+30.00	55.00	695641.8429	1557781.3140
L	25+00.00	58.00	695616.3987	1557797.4879
L	27+50.00	35.00	695828.3650	1557687.0971
L	27+50.00	65.00	695834.3647	1557716.4910
L	28+05.00	70.00	695883.7430	1557713.8126
L	28+05.00	35.00	695879.7122	1557679.0455
L	28+85.00	-35.00	695951.1182	1557600.2978
L	28+85.00	-70.00	695947.0873	1557565.5307
L	29+50.00	35.00	696023.7474	1557662.3462
L	29+50.00	65.00	696027.2024	1557692.1466
L	30+00.00	70.00	696077.4455	1557691.3549
L	30+50.00	-65.00	696111.5653	1557551.4949
L	31+00.00	-60.00	696161.8084	1557550.7032
L	32+00.00	-60.00	696261.1430	1557539.1865
L	31+50.00	52.00	696224.3744	1557656.1996
L	33+00.00	-72.00	696359.0956	1557515.7496
L	34+15.00	71.00	696491.1000	1557644.1203
L	33+30.00	60.00	696404.0981	1557643.4163
L	38+60.00	37.48	696923.0209	1557484.1401
L	38+60.00	47.51	696927.2126	1557493.2556
L	39+29.76	54.92	696995.2814	1557468.2568
L	39+65.91	54.92	697027.3871	1557451.6432
L	33+00.00	-85.00	696357.5984	1557502.8361
L	34+60.96	-97.17	696511.0750	1557471.0562
L	30+17.00	-80.00	696077.0573	1557540.3952
L	27+65.00	-80.00	695822.0632	1557571.2290
L	37+72.50	33.00	696838.8603	1557515.0426
L	37+72.50	37.50	696840.4988	1557519.2337
L	37+82.50	37.50	696850.0329	1557515.4701
L	37+82.50	33.07	696848.3937	1557511.3584
L	20+70.00	-40.00	695188.4855	1557906.9037
L	33+86.61	-76.00	696444.6715	1557501.8013
L	34+65.45	-84.00	696517.4192	1557483.3449
L	34+55.00	44.31	696528.2577	1557611.6147
L	39+69.17	-58.14	696978.3236	1557349.7362
L	39+73.69	-49.82	696986.1599	1557355.0496
L	39+84.24	-57.58	696991.9638	1557343.3041
L	39+77.69	-64.32	696983.0501	1557340.3299

ROW MARKER PERMANENT EASEMENT

ALIGN	STATION	OFFSET	NORTH	EAST
Y2	12+20.55	46.01	696986.6783	1557323.5897
Y2	12+23.24	39.01	696994.1314	1557322.7523
Y2	12+28.76	50.29	696986.6536	1557332.8480
Y2	12+32.97	44.08	696994.1022	1557333.7251

## DATUM DESCRIPTION

THE LOCALIZED COORDINATE SYSTEM DEVELOPED FOR THIS PROJECT IS BASED ON THE STATE PLANE COORDINATES ESTABLISHED BY NCDOT FOR MONUMENT "P3414P-10" WITH NAD 83/NSRS 2007 STATE PLANE GRID COORDINATES OF NORTHING: 666744.654(+) EASTING: 1531939.796(+) ELEVATION: 821.60(++)

THE AVERAGE COMBINED GRID FACTOR USED ON THIS PROJECT (GROUND TO GRID) IS: 0.99985378

THE N.C. LAMBERT GRID BEARING AND LOCALIZED HORIZONTAL GROUND DISTANCE FROM "P3414P-10" TO -L- STATION 10+00.0 IS

N 43°57'00.8" E 38264.72'

ALL LINEAR DIMENSIONS ARE LOCALIZED HORIZONTAL DISTANCES  
VERTICAL DATUM USED IS NAVD 88

**NOTES:**

1. THE SITE CALIBRATION SHOWN IS BASED UPON A NETWORK TIED TO THE HARN (HIGH ACCURACY REFERENCE NETWORK) NAD 83/NSRS 2007 ADJUSTMENT. THIS CALIBRATION WILL ALLOW THE END USER TO WORK WITHIN THE SAME COORDINATE SYSTEM WHEN USING RTK (REAL TIME KINEMATIC) GPS AND A LOCAL BASE STATION. IF ANOTHER SYSTEM SUCH AS VRS (VIRTUAL REFERENCE STATION) IS USED, ADDITIONAL FIELD TIES MAY BE NEEDED TO REDUCE POSSIBLE ERRORS, OR BIASES.

2. THE CONTROL DATA FOR THIS PROJECT CAN BE FOUND ELECTRONICALLY BY SELECTING PROJECT CONTROL DATA AT:  
[HTTP://WWW.NCDOT.ORG/DOH/PRECONSTRUCT/HIGHWAY/LOCATION/PROJECT/](http://www.ncdot.org/doh/preconstruct/highway/location/project/)

THE FILES TO BE FOUND ARE AS FOLLOWS:

- P3414P\_LS\_GPSCALIB.HTML
- P3414P\_LS\_WGS84.TXT
- P3414P\_LS\_LOCAL.TXT
- U3459\_LS\_CONTROL.TXT

THE WGS84 AND LOCAL FILES ARE COMMA DELIMITED AND CAN BE USED TO REPRODUCE THE SITE CALIBRATION FOR THE END USER'S GPS EQUIPMENT. IF FURTHER INFORMATION IS NEEDED, PLEASE CONTACT THE LOCATION AND SURVEYS UNIT.



INDICATES GEODETIC CONTROL MONUMENTS USED OR SET FOR HORIZONTAL PROJECT CONTROL BY THE NCDOT LOCATION AND SURVEYS UNIT. PROJECT CONTROL ESTABLISHED USING GLOBAL POSITIONING SYSTEM. NETWORK ESTABLISHED FROM EXISTING HARN MONUMENTATION. SEE GPS CALIBRATION SHEET FOR HORIZONTAL AND VERTICAL COORDINATE VALUES.

7/17/2012  
At-Rail-Roadway-Proj-U3459-1s-1g.dgn  
Drawn: J. Hillman  
Checked: J. Hillman



STATE OF NORTH CAROLINA  
DIVISION OF HIGHWAYS

CENTERLINE COORDINATE LIST

Point #	Chain	Station	Northing (Y)	Easting (X)
1	L	10+00.0000	694293.0788	1558496.7771
2	L	10+50.0000	694336.4187	1558471.8442
3	L	11+00.0000	694379.7587	1558446.9112
4	L	11+50.0000	694423.0986	1558421.9783
5	L	12+00.0000	694466.3827	1558396.9489
6	L	12+50.0000	694509.4284	1558371.5117
7	L	13+00.0000	694552.2175	1558345.6453
8	L	13+50.0000	694594.7458	1558319.3523
9	L	14+00.0000	694637.0181	1558292.6496
10	L	14+50.0000	694679.2171	1558265.8308
11	L	15+00.0000	694721.4161	1558239.0121
12	L	15+50.0000	694763.6151	1558212.1934
13	L	16+00.0000	694805.8141	1558185.3747
14	L	16+50.0000	694848.0131	1558158.5560
15	L	17+00.0000	694890.2121	1558131.7372
16	L	17+50.0000	694932.4111	1558104.9185
17	L	18+00.0000	694974.7364	1558078.2998
18	L	18+50.0000	695017.3256	1558052.1056
19	L	19+00.0000	695060.1746	1558026.3386
20	L	19+50.0000	695103.2792	1558001.0013
21	L	20+00.0000	695146.6349	1557976.0963
22	L	20+50.0000	695190.2376	1557951.6261
23	L	21+00.0000	695234.0827	1557927.5932
24	L	21+50.0000	695278.1660	1557903.9999
25	L	22+00.0000	695322.4830	1557880.8486
26	L	22+50.0000	695367.0293	1557858.1416
27	L	23+00.0000	695411.6853	1557835.6507
28	L	23+50.0000	695456.3413	1557813.1598
29	L	24+00.0000	695500.9973	1557790.6688
30	L	24+50.0000	695545.6533	1557768.1779
31	L	25+00.0000	695590.3092	1557745.8869
32	L	25+50.0000	695634.9652	1557723.1960
33	L	26+00.0000	695679.6521	1557700.7672
34	L	26+50.0000	695725.5012	1557680.8570
35	L	27+00.0000	695772.8485	1557664.8323
36	L	27+50.0000	695821.3652	1557652.8042
37	L	28+00.0000	695870.7148	1557644.8562
38	L	28+50.0000	695920.3819	1557639.0958
39	L	29+00.0000	695970.0492	1557633.3374
40	L	29+50.0000	696019.7165	1557627.5791
41	L	30+00.0000	696069.3838	1557621.8207
42	L	30+50.0000	696119.0511	1557616.0624
43	L	31+00.0000	696168.7184	1557610.3040
44	L	31+50.0000	696218.3857	1557604.5456
45	L	32+00.0000	696268.0530	1557598.7873
46	L	32+50.0000	696317.7204	1557593.0289
47	L	33+00.0000	696367.3877	1557587.2705
48	L	33+50.0000	696417.0550	1557581.5122
49	L	34+00.0000	696466.7223	1557575.7538
50	L	34+50.0000	696516.3896	1557570.0000
51	L	35+00.0000	696565.4569	1557564.2462
52	L	35+50.0000	696614.5242	1557558.4924
53	L	36+00.0000	696662.5915	1557552.7386
54	L	36+50.0000	696711.6588	1557547.0000
55	L	37+00.0000	696758.7261	1557541.2562
56	L	37+50.0000	696805.7934	1557535.5124
57	L	38+00.0000	696852.8607	1557529.7686
58	L	38+50.0000	696899.9280	1557524.0248
59	L	39+00.0000	696947.0000	1557518.2810
60	L	39+50.0000	696994.0723	1557512.5372
61	L	40+00.0000	697042.1446	1557506.7934
62	L	40+34.6477	697063.1969	1557371.2773
63	Y1	10+00.0000	694756.7158	1558216.5781
64	Y1	10+50.0000	694785.0169	1558257.7119
65	Y1	11+00.0000	694825.0409	1558287.1214
66	Y1	11+50.0000	694873.3581	1558298.6233
67	Y1	12+00.0000	694922.9293	1558292.9071
68	Y1	12+50.0000	694972.2645	1558284.7807
69	Y1	13+00.0000	695021.5997	1558276.6543
70	Y1	13+50.0000	695070.9349	1558268.5280
71	Y1	14+00.0000	695120.2701	1558260.4016
72	Y1	14+03.7315	695123.9520	1558259.7951
73	Y4	2+00.0000	695027.1232	1556655.0471
74	Y4	2+50.0000	695058.6530	1556693.8527
75	Y4	3+00.0000	695090.1827	1556732.6583
76	Y4	3+50.0000	695121.7125	1556771.4639
77	Y4	4+00.0000	695153.1604	1556810.3355
78	Y4	4+50.0000	695183.7213	1556849.9066
79	Y4	5+00.0000	695213.1714	1556890.3112
80	Y4	5+50.0000	695241.4878	1556931.5182

Point #	Chain	Station	Northing (Y)	Easting (X)
81	Y4	6+00.0000	695268.6489	1556973.4958
82	Y4	6+50.0000	695294.6336	1557016.2115
83	Y4	7+00.0000	695319.4219	1557059.6325
84	Y4	7+50.0000	695342.9946	1557103.7252
85	Y4	8+00.0000	695365.3336	1557148.4556
86	Y4	8+50.0000	695386.4216	1557193.7892
87	Y4	9+00.0000	695406.2424	1557239.6910
88	Y4	9+50.0000	695424.7807	1557286.1256
89	Y4	10+00.0000	695442.0225	1557333.0570
90	Y4	10+50.0000	695458.4223	1557380.2902
91	Y4	11+00.0000	695473.6489	1557427.9137
92	Y4	11+50.0000	695487.5829	1557475.9314
93	Y4	12+00.0000	695500.2142	1557524.3080
94	Y4	12+50.0000	695511.5335	1557573.0083
95	Y4	13+00.0000	695521.5327	1557621.9967
96	Y4	13+50.0000	695530.2324	1557671.2328
97	Y4	14+00.0000	695538.5117	1557720.5426
98	Y4	14+50.0000	695546.7909	1557769.8523
99	Y4	15+00.0000	695555.0702	1557819.1621
100	Y4	15+50.0000	695563.3495	1557868.4719
101	Y4	16+00.0000	695571.6287	1557917.7817
102	Y4	16+50.0000	695579.9080	1557967.0914
103	Y4	17+00.0000	695588.1872	1558016.4012
104	Y4	17+46.6099	695595.9051	1558062.3676
105	Y2	9+00.0000	696880.0831	1557017.7975
106	Y2	9+50.0000	696903.0820	1557062.1941
107	Y2	10+00.0000	696926.0808	1557106.5906
108	Y2	10+50.0000	696949.0796	1557150.9872
109	Y2	11+00.0000	696972.0784	1557195.3838
110	Y2	11+50.0000	696995.0773	1557239.7803
111	Y2	12+00.0000	697018.0761	1557284.1769
112	Y2	12+50.0000	697041.0749	1557328.5734
113	Y2	13+00.0000	697064.0738	1557372.9700
114	Y2	13+50.0000	697087.0726	1557417.3665
115	Y2	14+00.0000	697110.0714	1557461.7631
116	Y2	14+50.0000	697133.0703	1557506.1596
117	Y2	15+00.0000	697156.0691	1557550.5562
118	Y2	15+50.0000	697179.0679	1557594.9527
119	Y2	16+00.0000	697202.0667	1557639.3493
120	Y2	16+50.0000	697225.0656	1557683.7458
121	Y2	17+00.0000	697248.0644	1557728.1424
122	Y2	17+50.0000	697271.0632	1557772.5389
123	Y2	18+00.0000	697294.0621	1557816.9355
124	Y2	18+50.0000	697317.0609	1557861.3320
125	Y2	19+00.0000	697340.0597	1557905.7286
126	Y2	19+50.0000	697363.0586	1557950.1251
127	Y2	20+00.0000	697386.0574	1557994.5217
128	Y2	20+50.0000	697409.0563	1558038.9182
129	Y2	21+00.0000	697432.0551	1558083.3148
130	Y2	21+50.0000	697455.0540	1558127.7113
131	Y2	22+00.0000	697478.0529	1558172.1078
132	Y2	22+50.0000	697501.0517	1558216.5043
133	Y2	23+00.0000	697524.0506	1558260.9008
134	Y2	23+50.0000	697547.0494	1558305.2973
135	Y2	24+00.0000	697570.0483	1558349.6938
136	Y2	24+36.4525	697593.0471	1558394.0903
137	Y2A	10+00.0000	697063.1969	1557371.2773
138	Y2A	10+50.0000	697099.0895	1557336.4683
139	Y2A	11+00.0000	697132.5209	1557299.3165
140	Y2A	11+50.0000	697163.1390	1557259.7893
141	Y2A	12+00.0000	697193.6090	1557220.1462
142	Y2A	12+20.0109	697205.8036	1557204.2802
143	Y2B	10+00.0000	697144.1987	1557284.4317
144	Y2B	10+50.0000	697188.3747	1557304.1575
145	Y2B	11+00.0000	697233.7113	1557283.6642
146	Y2B	11+33.7511	697263.6999	1557268.1779
147	Y3B	10+00.0000	696540.2787	1557147.1333
148	Y3B	10+50.0000	696563.3222	1557191.5067
149	Y3B	11+00.0000	696586.3658	1557235.8801
150	Y3B	11+50.0000	696609.4093	1557280.2535
151	Y3B	12+00.0000	696632.4528	1557324.6268
152	Y3B	12+50.0000	696655.4963	1557369.0002
153	Y3B	13+00.0000	696678.5399	1557413.3736
154	Y3B	13+50.0000	696701.5834	1557457.7469
155	Y3B	14+00.0000	696724.6269	1557502.1203
156	Y3B	14+50.0000	696747.6704	1557546.4937
157	Y3B	15+00.0000	696770.7139	1557590.8671
158	Y3B	15+50.0000	696793.7575	1557635.2404

Point #	Chain	Station	Northing (Y)	Easting (X)
159	Y3B	16+00.0000	696818.7269	1557678.5358
160	Y3B	16+50.0000	696847.7122	1557719.2602
161	Y3B	17+00.0000	696877.7056	1557759.2652
162	Y3B	17+50.0000	696907.6989	1557799.2702
163	Y3B	18+00.0000	696934.0806	1557841.3999
164	Y3B	18+46.9649	696934.7678	1557887.7952
165	Y3C	10+00.0000	696540.2787	1557147.1333
166	Y3C	10+50.0000	696584.6809	1557124.1454
167	Y3C	11+00.0000	696629.0831	1557101.1574
168	Y3C	11+50.0000	696673.4852	1557078.1694
169	Y3C	12+00.0000	696717.8874	1557055.1814
170	Y3C	12+50.0000	696762.2896	1557032.1934
171	Y3C	13+00.0000	696806.6917	1557009.2054
172	Y3C	13+50.0000	696851.0939	1556986.2175
173	Y3C	13+61.2143	696861.0527	1556981.0616
174	Y1A	10+00.0000	696643.6652	1557940.5084
175	Y1A	10+50.0000	696689.6122	1557920.8086
176	Y1A	11+00.0000	696736.6310	1557903.8207
177	Y1A	11+50.0000	696784.8942	1557890.8705
178	Y1A	12+00.0000	696834.3618	1557883.8046
179	Y1A	12+50.0000	696884.3201	1557882.7353
180	Y1A	13+00.0000	696934.0448	1557887.6784
181	Y1A	13+50.0000	696983.0401	1557897.6184
182	Y1A	14+00.0000		

0302DEL\_P12

1/22/02

PAVEMENT SCHEDULE	
C1	PROP. APPROX. 1½" ASPHALT CONCRETE SURFACE COURSE, TYPE S9.5B, AT AN AVERAGE RATE OF 168 LBS. PER SQ. YD.
C2	PROP. APPROX. 3" ASPHALT CONCRETE SURFACE COURSE, TYPE S9.5B, AT AN AVERAGE RATE OF 168 LBS. PER SQ. YD. IN EACH OF TWO LAYERS.
C3	PROP. VAR. DEPTH ASPHALT CONCRETE SURFACE COURSE, TYPE S9.5B, AT AN AVERAGE RATE OF 112 LBS. PER SQ. YD. PER 1" DEPTH. TO BE PLACED IN LAYERS NOT TO EXCEED 2" IN DEPTH.
D1	PROP. APPROX. 4" ASPHALT CONCRETE INTERMEDIATE COURSE, TYPE I19.0B, AT AN AVERAGE RATE OF 456 LBS. PER SQ. YD.
D2	PROP. VAR. DEPTH ASPHALT CONCRETE INTERMEDIATE COURSE, TYPE I19.0B, AT AN AVERAGE RATE OF 114 LBS. PER SQ. YD. PER 1" DEPTH, TO BE PLACED IN LAYERS NOT LESS THAN 2½" IN DEPTH OR GREATER THAN 4" IN DEPTH.
E1	PROP. APPROX. 4" ASPHALT CONCRETE BASE COURSE, TYPE B25.0B, AT AN AVERAGE RATE OF 456 LBS. PER SQ. YD.
E2	PROP. VAR. DEPTH ASPHALT CONCRETE BASE COURSE, TYPE B25.0B, AT AN AVERAGE RATE OF 114 LBS. PER SQ. YD. PER 1" DEPTH. TO BE PLACED IN LAYERS NOT LESS THAN 3" IN DEPTH OR GREATER THAN 5½" IN DEPTH.
R	2'-6" CONCRETE CURB AND GUTTER.
S	4" CONCRETE SIDEWALK.
T	EARTH MATERIAL.
U	EXISTING PAVEMENT.
W	VARIABLE DEPTH ASPHALT PAVEMENT (SEE STANDARD WEDGING DETAIL)

NOTE: PAVEMENT EDGE SLOPES ARE 1:1 UNLESS SHOWN OTHERWISE.

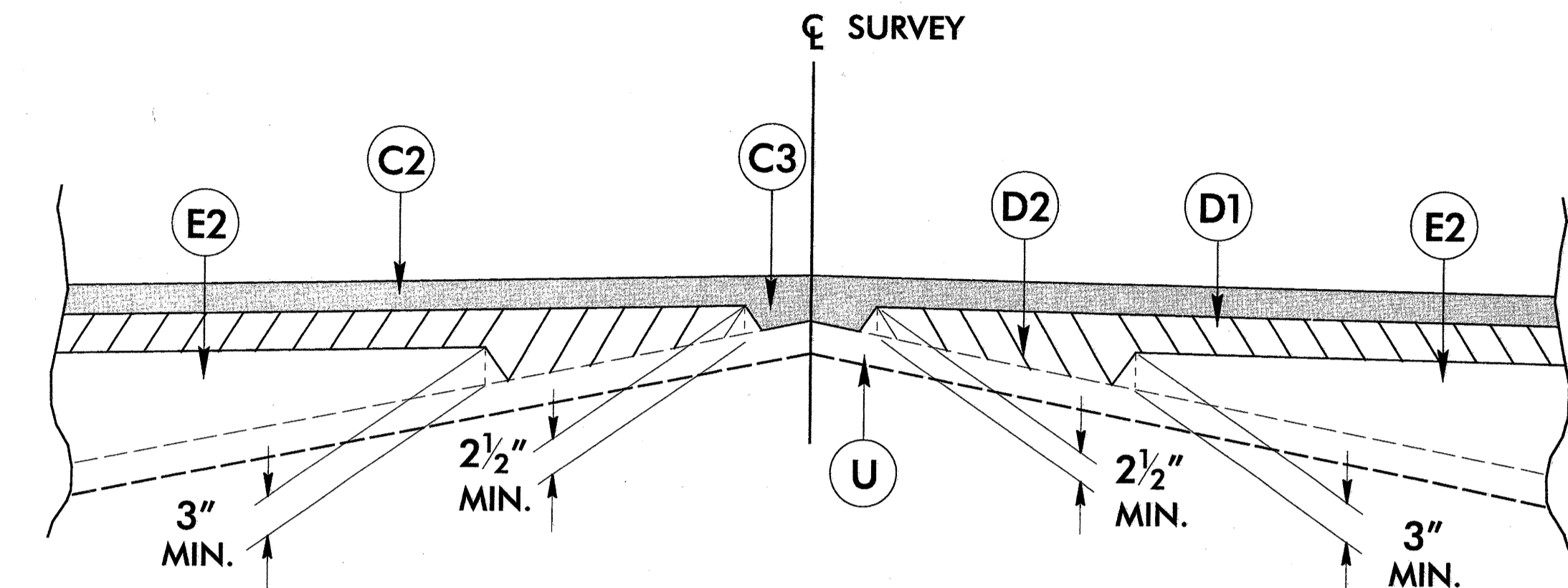

Detail Showing Method of Wedging

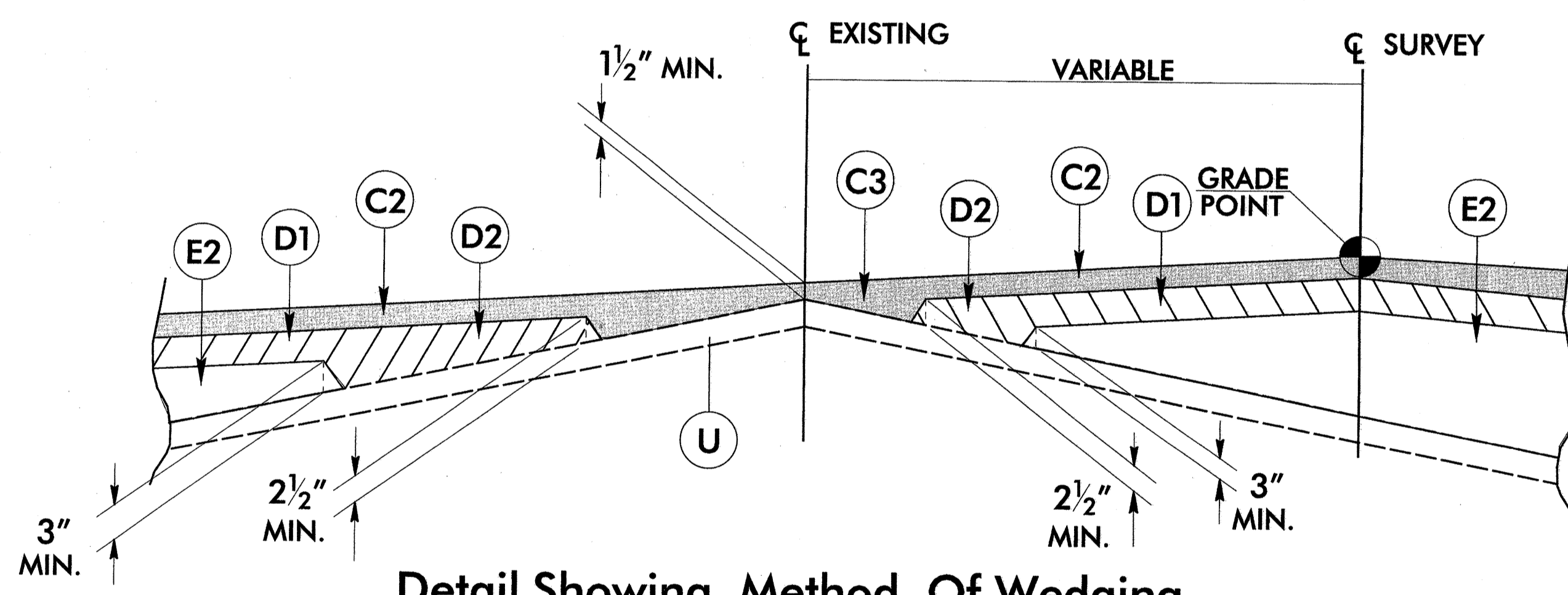

Detail Showing Method Of Wedging

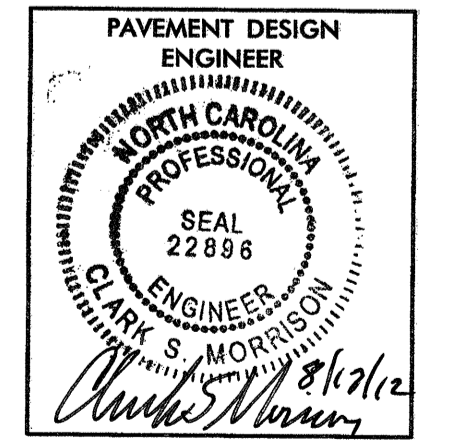

Florence & Hutcheson, Inc.  
 7/17/2012  
 R:\Rail-Roadway\Proj\KLU\KLU\Rail\_rdy\_fyp.dgn

NO.	BY	DATE	REVISION

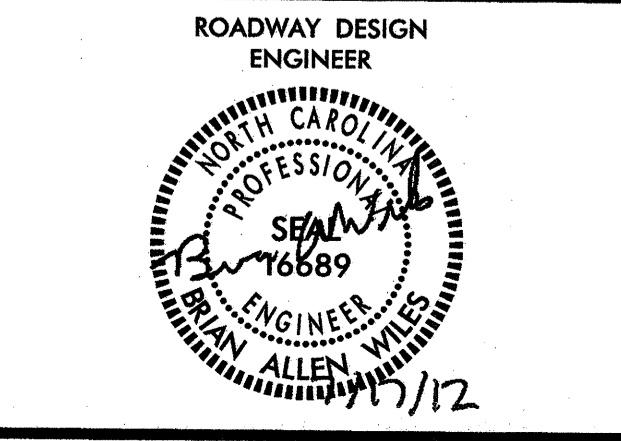

NORTH CAROLINA DEPARTMENT OF TRANSPORTATION  
**RAIL DIVISION**  
 PREPARED BY: **ENGINEERING & SAFETY BRANCH**  

 MAIL: 1556 MAIL SERVICE CENTER RALEIGH, NC 27699-1556  
 DELIVERY: 660 CAPITAL BOULEVARD RALEIGH, NC 27603  
 PHONE: (919) 715-8803 FAX: (919) 715-8804

PROJECT	U-3459 - KLUMAC ROAD		
TITLE	SHEET 2 ROADWAY PAVEMENT SCHEDULE		
LOCATION	KLUMAC ROAD (SR 2541) IN SALISBURY, NC	MILE POST	MP 335.2
DGN BY	BAW	RAILROAD	NORTH CAROLINA RAILROAD/NORFOLK SOUTHERN
DWN BY	YTM	VAL SEC	
CHK BY	BAW	DATE	OCT. 2011
		SCALE	NONE
		SHEET	OF

DCN 0302DEL\_P12

1/22/02

PAVEMENT SCHEDULE	
C1	1½" S9.5B
C2	3" S9.5B
C3	VAR. S9.5B
D1	4" I19.5B
D2	VAR. I19.0B
E1	4" B25.0B
E2	VAR. B25.0B
R1	2'-6" C & G
S	4" SIDEWALK
T	EARTH MATERIAL
U	EXIST. PVMT
W	WEDGING

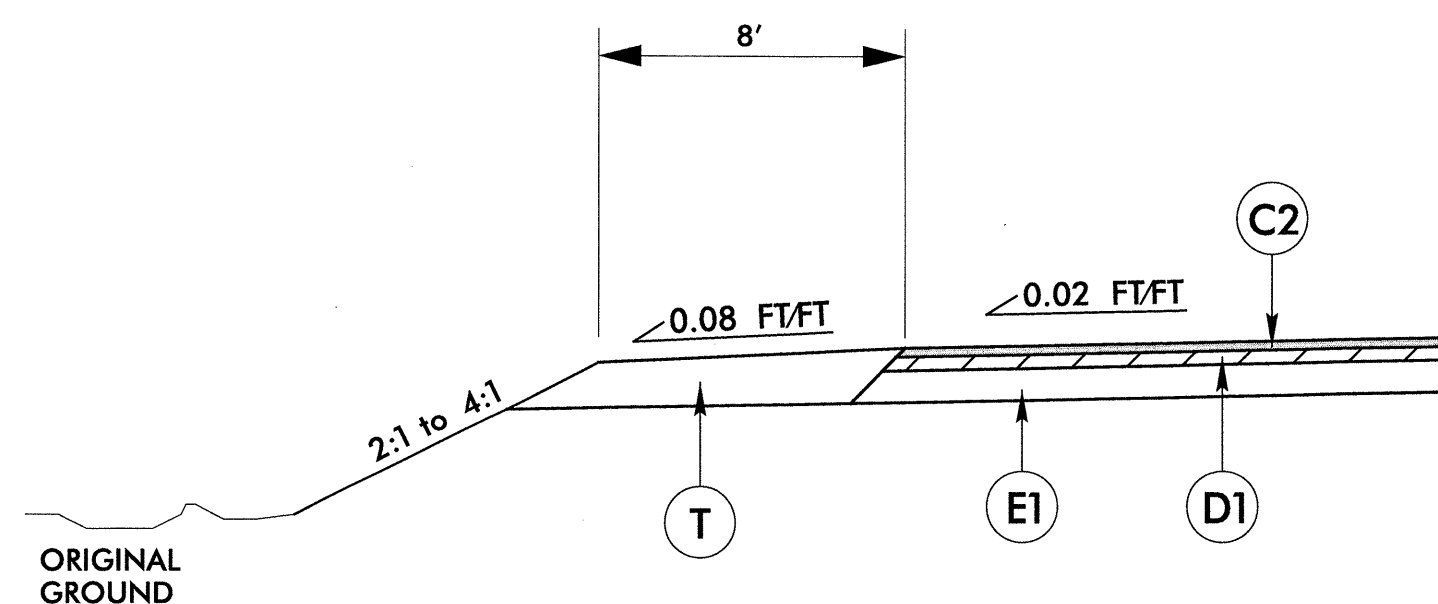

**TYPICAL SECTION NO. 1A**  
 -L- (Klumac Road)

USE TYPICAL SECTION NO. 1A  
 -L- STA. 10+00.00 TO STA. 11+57.90 Left  
 -L- STA. 10+00.00 TO STA. 11+16.28 Right

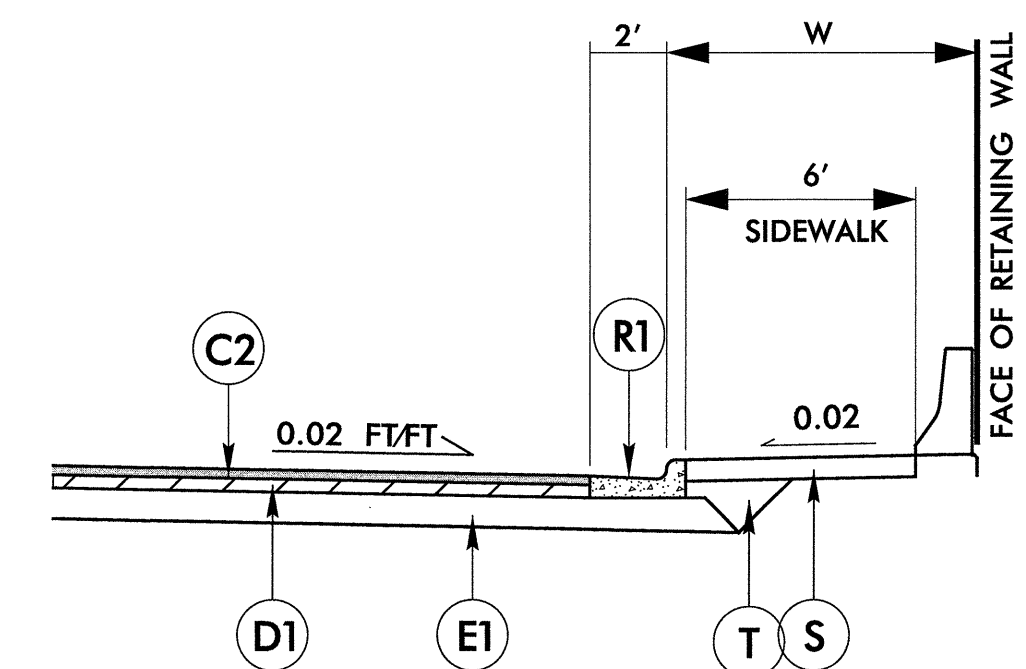

**TYPICAL SECTION NO. 1B**  
 -L- (Klumac Road)

USE TYPICAL SECTION NO. 1B

	W
-L- STA. 35+45.00 TO STA. 36+05.00 Left	8'
-L- STA. 36+46.25 TO STA. 38+40.00 Left	Varies
-L- STA. 34+30.00 TO STA. 35+12.00 Right	8'
-L- STA. 35+55.00 TO STA. 36+16.75 Right	8'
-L- STA. 36+78.75 TO STA. 37+74.00 Right	8'

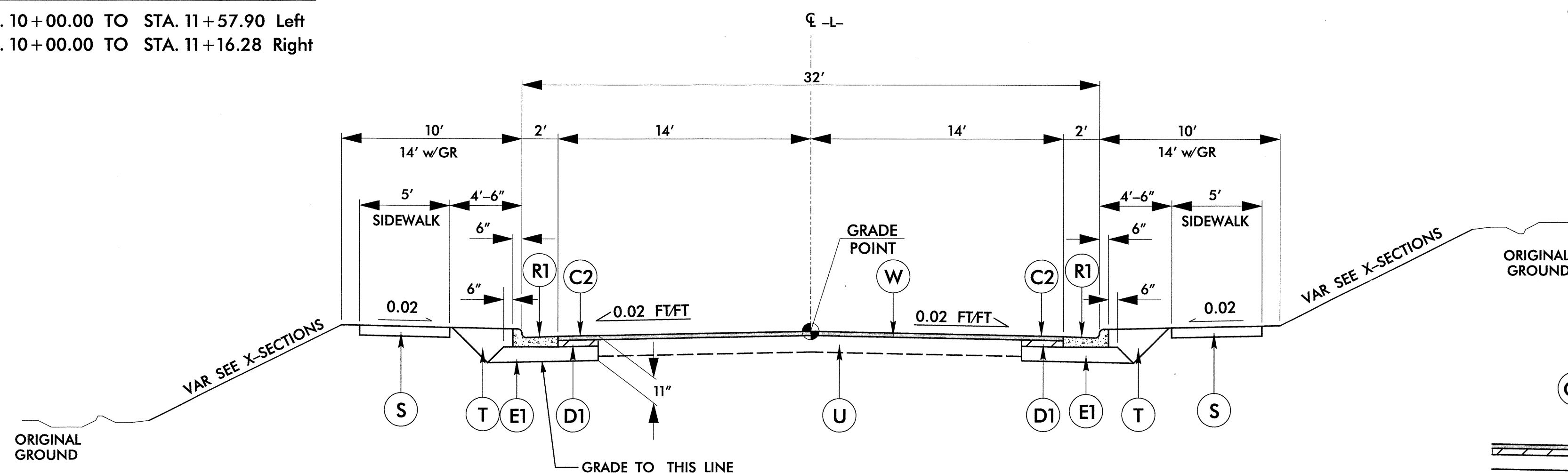

**TYPICAL SECTION NO. 1D**  
 -L- (Klumac Road)

USE TYPICAL SECTION NO. 1D  
 -L- STA. 10+00.00 TO STA. 13+00.00

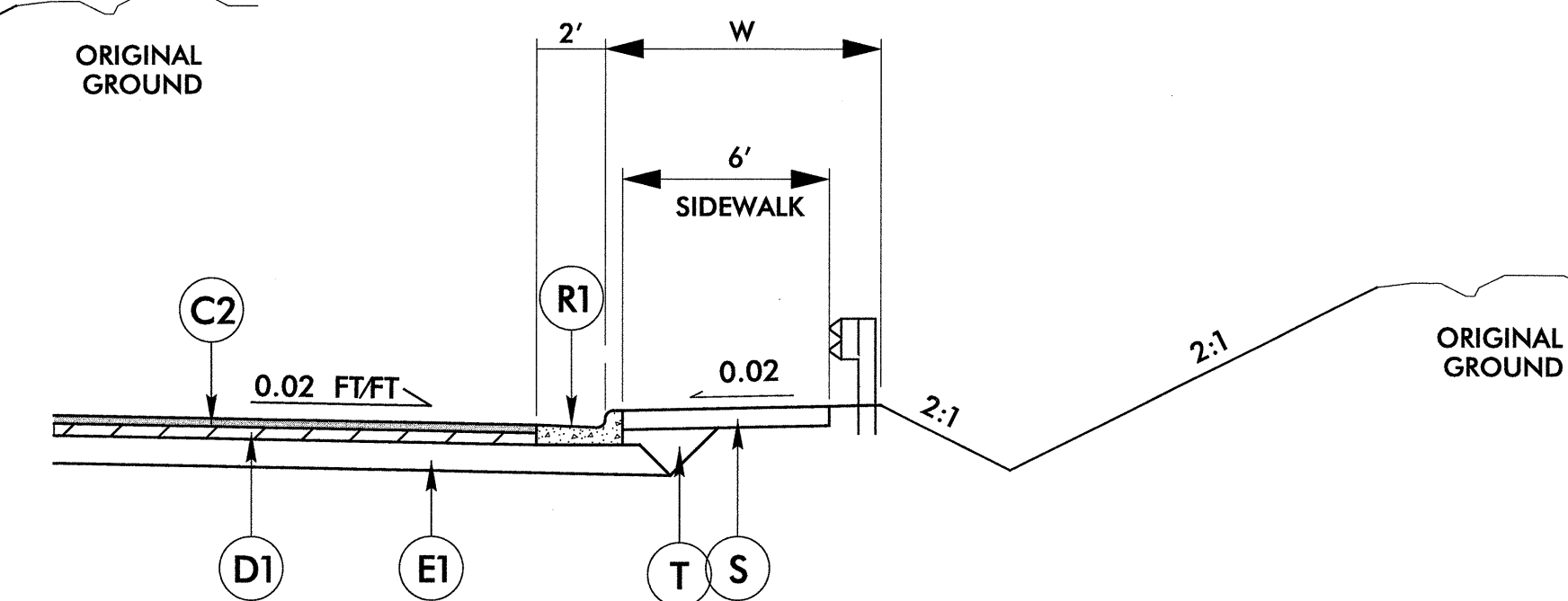

**TYPICAL SECTION NO. 1C**  
 -L- (Klumac Road)

USE TYPICAL SECTION NO. 1C

	W
-L- STA. 36+05.00 TO STA. 36+46.25 Left	Varies
-L- STA. 35+12.00 TO STA. 35+55.00 Right	8.5'
-L- STA. 36+16.75 TO STA. 36+78.25 Right	8.5'

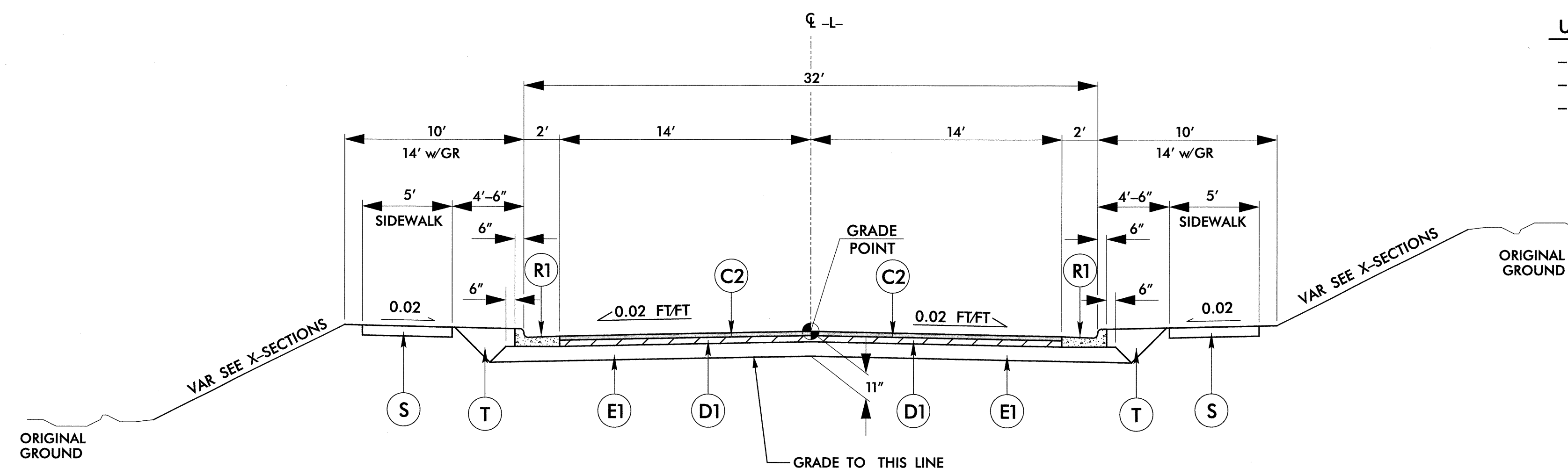

**TYPICAL SECTION NO. 1**  
 -L- (Klumac Road)

USE TYPICAL SECTION NO. 1  
 -L- STA. 13+00.00 TO STA. 40+16.65

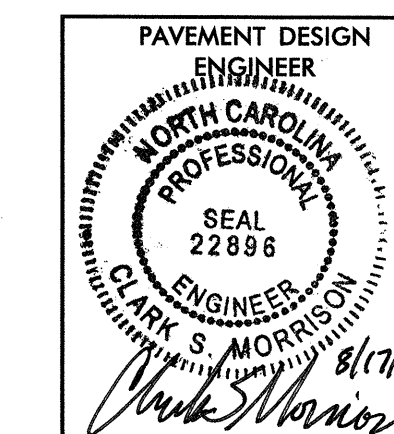

Florence & Hutcheson, Inc. 8/8/2002 R:\Rail-Roadway\Proj\KLUMAC\_Rail\_rdy\_fyp.dgn

NO.	BY	DATE	REVISION

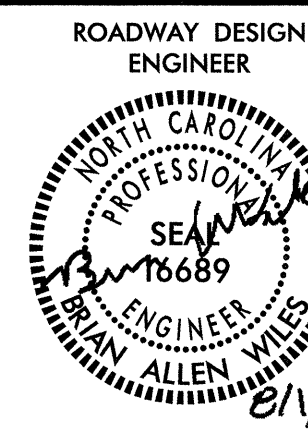

ROADWAY DESIGN ENGINEER

NORTH CAROLINA DEPARTMENT OF TRANSPORTATION

**RAIL DIVISION**

PREPARED BY: **ENGINEERING & SAFETY BRANCH**

MAIL SERVICE CENTER: 1526 MAIL SERVICE CENTER, RALEIGH, NC 27699-1556  
 DELIVERY: 260 CAPITAL BOULEVARD, RALEIGH, NC 27603  
 PHONE: (919) 715-8803  
 FAX: (919) 715-8804

PROJECT TITLE	U-3459 - KLUMAC ROAD		
	<b>SHEET 2-A</b> ROADWAY TYPICAL SECTION SHEET		
LOCATION	KLUMAC ROAD (SR 2541) IN SALISBURY, NC		
DGN BY	BAW	RAILROAD	NORTH CAROLINA RAILROAD/NORFOLK SOUTHERN
DWN BY	YTM	VAL SEC	
CHK BY	BAW	DATE	OCT. 2011
		SCALE	NONE
		MILE POST	MP 335.2
		SHEET	OF

0302DEL\_P12

PAVEMENT SCHEDULE	
C1	1½" S9.5B
C2	3" S9.5B
C3	VAR. S9.5B
D1	4" I19.5B
D2	VAR. I19.0B
E1	4" B25.0B
E2	VAR. B25.0B
R1	2'-6" C & G
S	4" SIDEWALK
T	EARTH MATERIAL
U	EXIST. PVMT
W	WEDGING

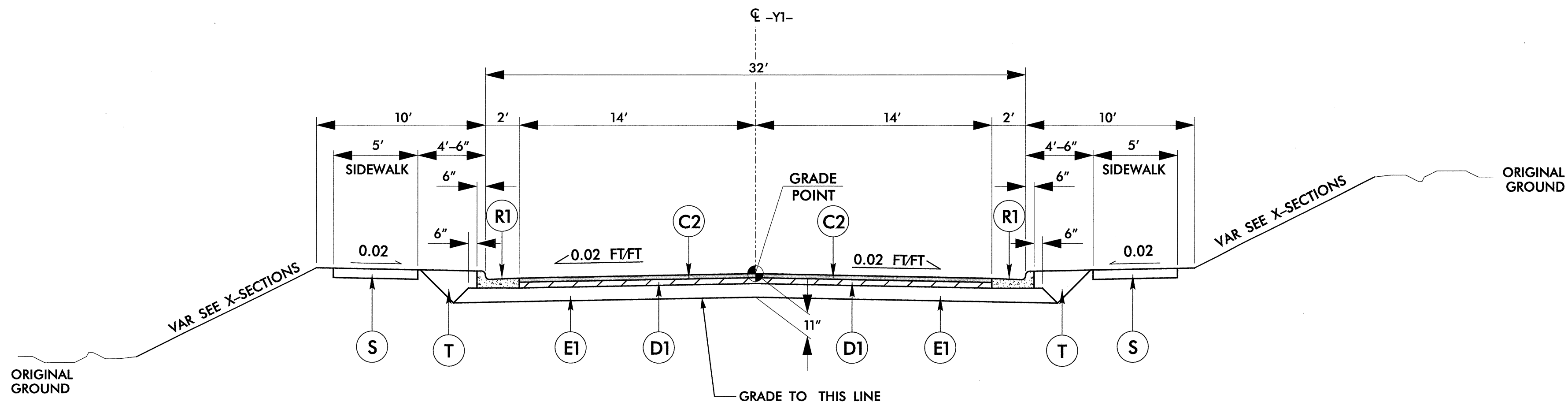

USE TYPICAL SECTION NO. 2  
 -Y1- STA. 10+14.00 TO STA. 12+25.00  
 NOTE: WEDGE/OVERLAY EXISTING PAVEMENT  
 -Y1- STA. 11+25 TO 12+25

TYPICAL SECTION NO. 2  
 -Y1-

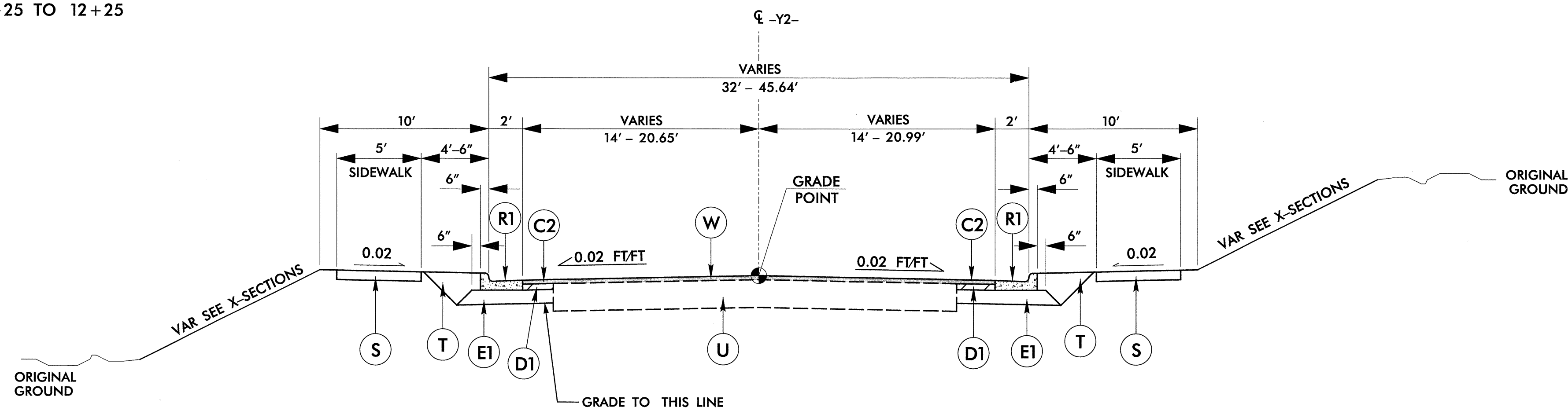

USE TYPICAL SECTION NO. 3  
 -Y2- STA. 11+45.00 TO STA. 14+65.00

TYPICAL SECTION NO. 3  
 -Y2- (S. Main St/US 29)

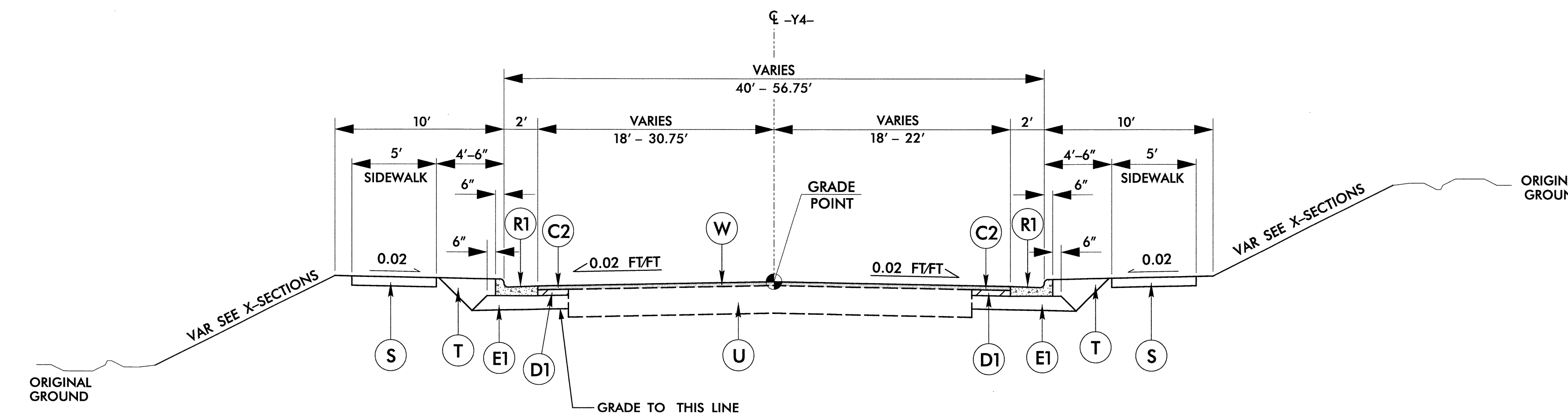

USE TYPICAL SECTION NO. 4  
 -Y4- STA. 13+05.00 TO STA. 14+26.96  
 -Y4- STA. 14+68.84 TO STA. 15+90.00

TYPICAL SECTION NO. 4  
 -Y4- (S Martin Luther King Jr Ave)

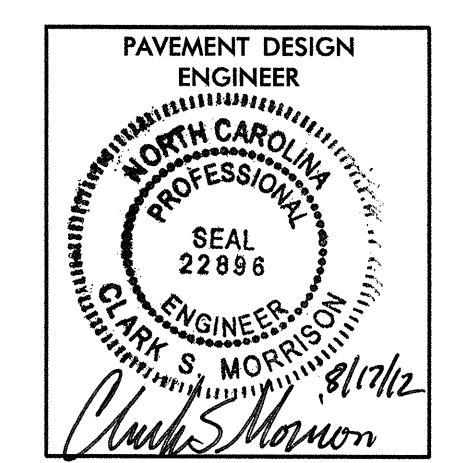

Florence & Hutcheson, Inc.  
 8/1/2012  
 R:\Rail-Roadway\Proj\KLU\KLU\Rail\rdy-tyr.dgn

NO.	BY	DATE	REVISION

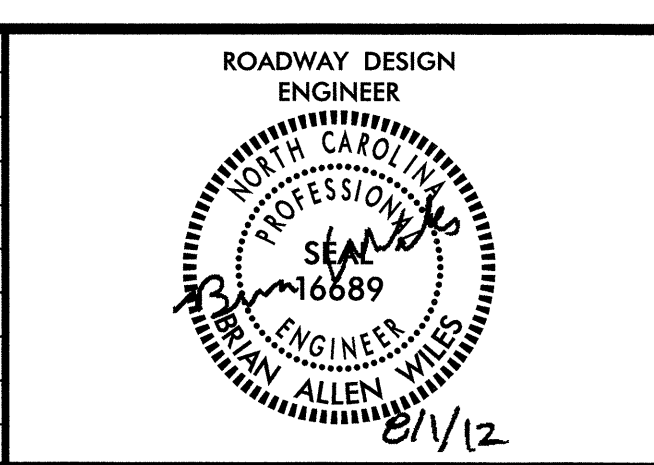

ROADWAY DESIGN ENGINEER

PREPARED BY: **ENGINEERING & SAFETY BRANCH**

MAIL: 1556 MAIL SERVICE CENTER RALEIGH, NC 27699-1556  
 DELIVERY: 800 CAPITAL BOULEVARD RALEIGH, NC 27603  
 PHONE: (919) 715-8803 FAX: (919) 715-8804

PROJECT	U-3459 - KLUMAC ROAD		
TITLE	SHEET 2-B ROADWAY TYPICAL SECTION SHEET		
LOCATION	KLUMAC ROAD (SR 2541) IN SALISBURY, NC		
DGN BY	BAW	RAILROAD	NORTH CAROLINA RAILROAD/NORFOLK SOUTHERN
DWN BY	YTM	VAL SEC	
CHK BY	BAW	DATE	OCT. 2011
		SCALE	NONE
		MILE POST	MP 335.2
		SHEET	OF

0302DEL\_P12

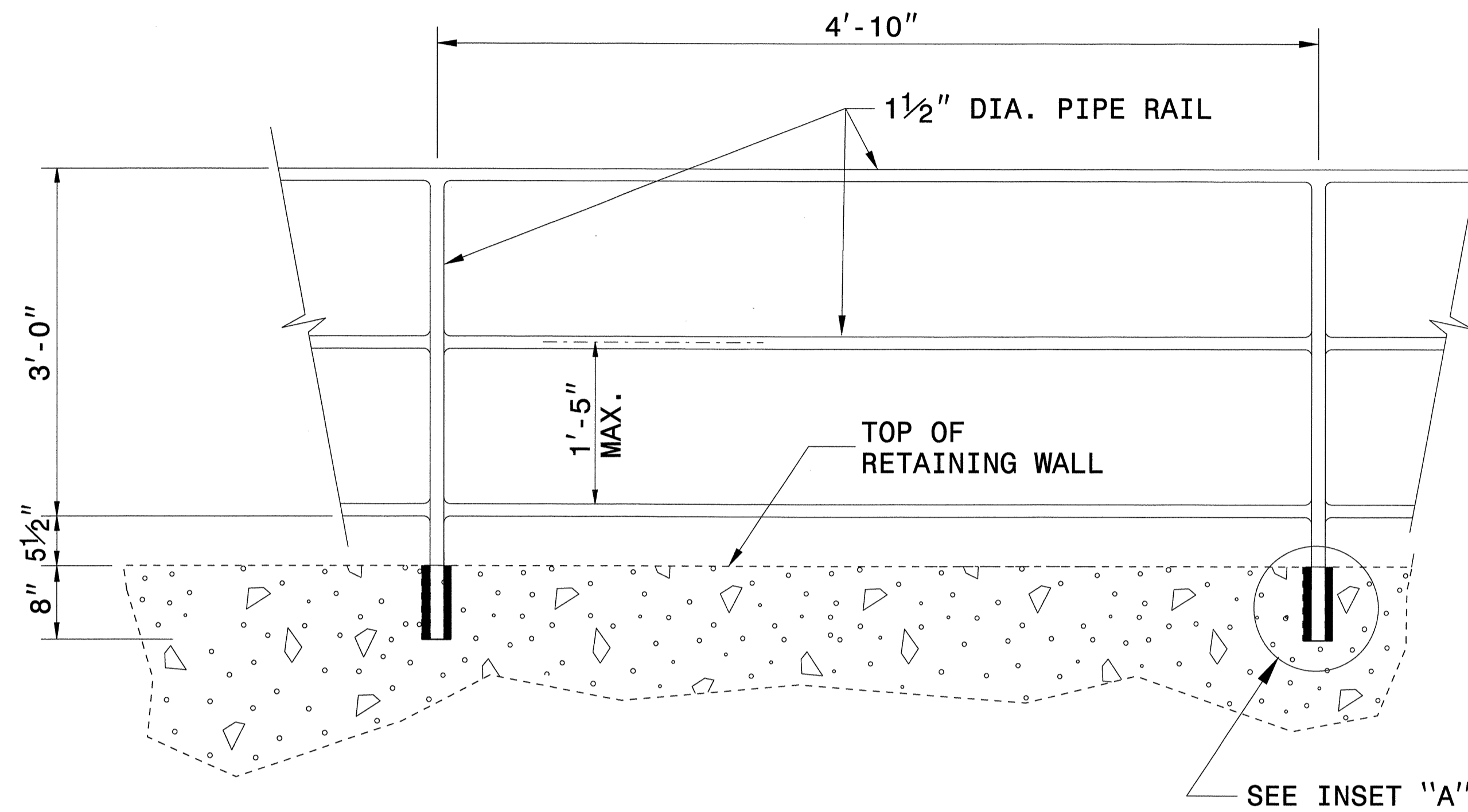

**ELEVATION OF PROPOSED PEDESTRIAN HANDRAIL**

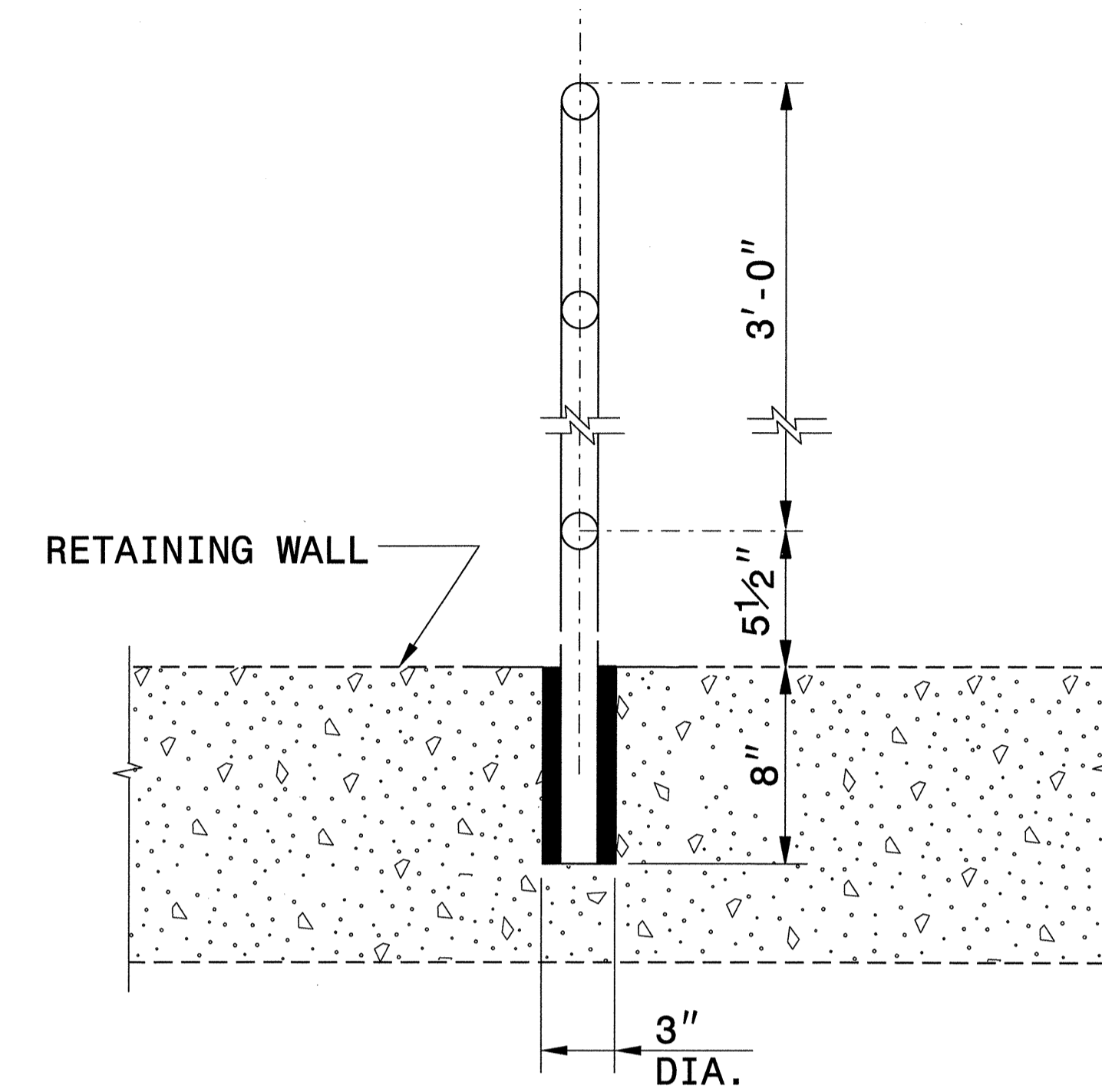

**INSET 'A'**

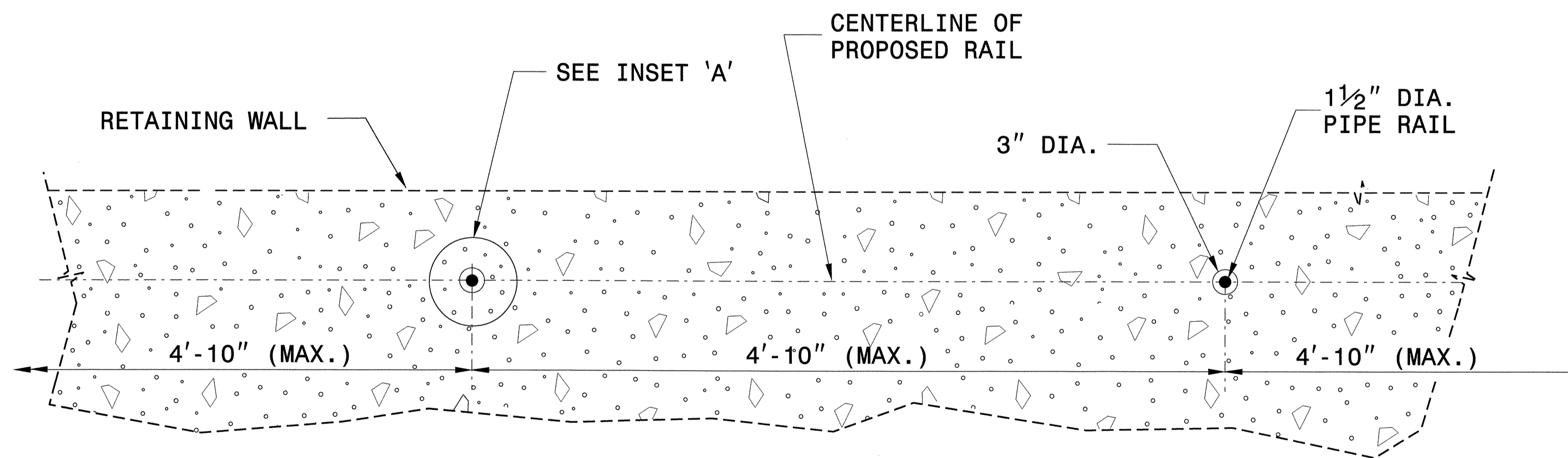

**PLAN VIEW**

**NOTES:**

CONSTRUCT PROPOSED STEEL PIPE RAIL OF 1 1/2" DIAMETER SCHEDULE 40 PLAIN END GALVANIZED STEEL PIPE MEETING THE REQUIREMENTS OF ASTM A53.

REPAIR GALVANIZING IN ACCORDANCE WITH SECTION 1076 OF THE NCDOT STANDARD SPECIFICATIONS.

PAINT, IF REQUIRED BY THE ENGINEER, IN ACCORDANCE WITH SECTION 1080 OF THE STANDARD SPECIFICATIONS.

WELD IN ACCORDANCE WITH ARTICLE 1072-18 OF THE STANDARD SPECIFICATIONS.

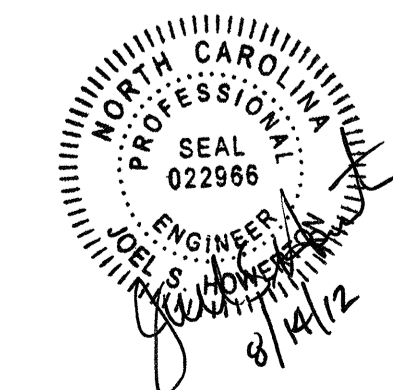

<b>CONTRACT STANDARDS AND DEVELOPMENT UNIT</b>	
Office 919-707-6850 FAX 919-250-4119	
<b>PROPOSED PEDESTRIAN SAFETY RAIL</b>	
ORIGINAL BY: E.E. WARD	DATE: 12-99
MODIFIED BY: T.S. Spell	DATE: 1-4-05
CHECKED BY:	DATE:
FILE SPEC.: w:\howerton\retain_wall_handrails.dgn	

\*\*\*\*\*  
 SYSTEMS  
 \*\*\*\*\*

DCM  
0302 DEL P12  
5/14/99

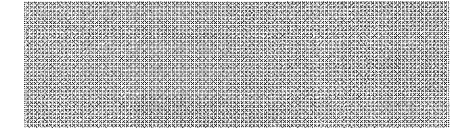
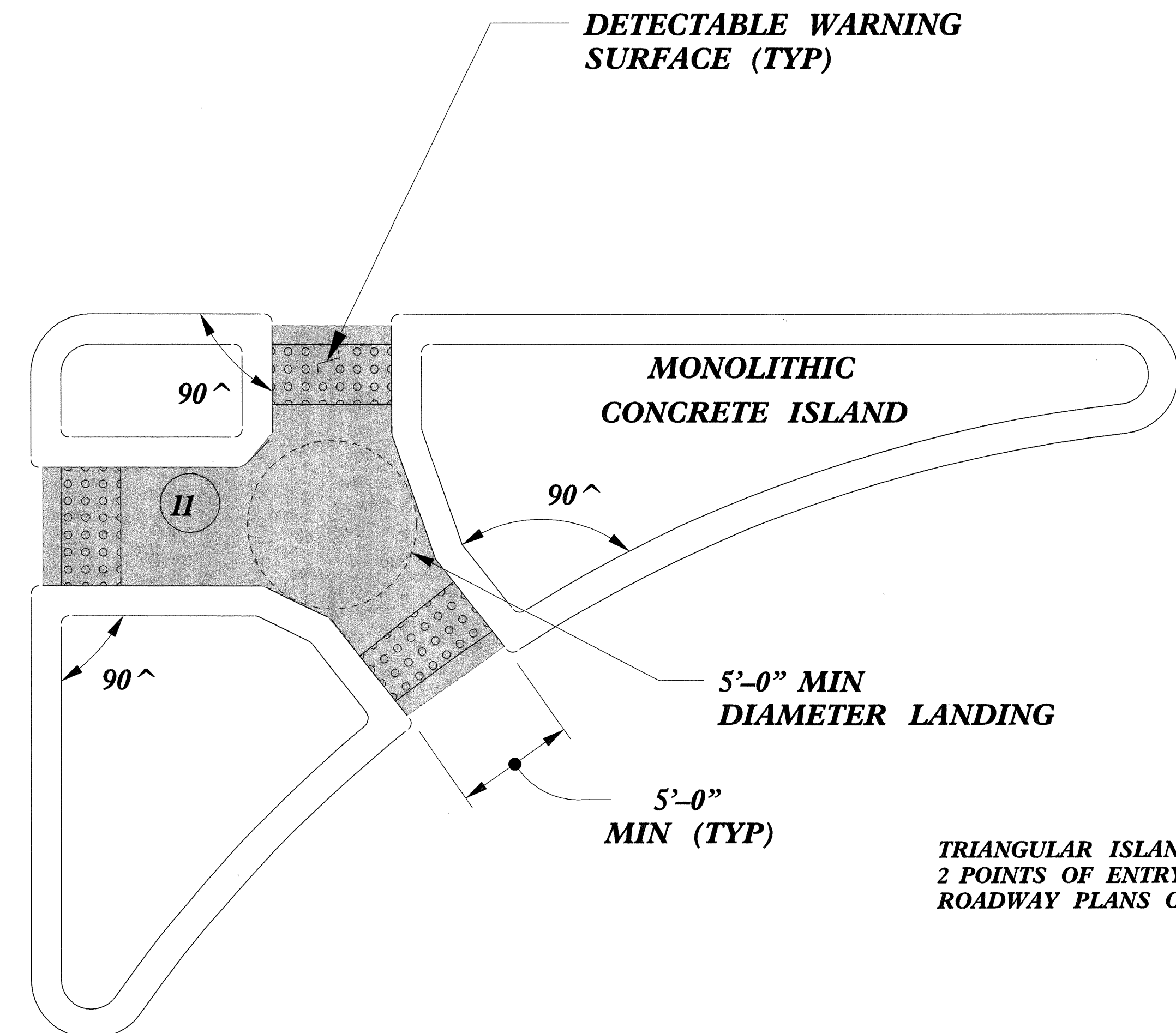

**PAY LIMITS FOR 1 CURB RAMP**

**TRIANGULAR ISLANDS MAY BE CONSTRUCTED WITH ONLY 2 POINTS OF ENTRY AND EXIT AS SHOWN IN THE ROADWAY PLANS OR AS DIRECTED BY THE ENGINEER.**

**TRIANGULAR ISLAND  
WITH CUT THROUGH**

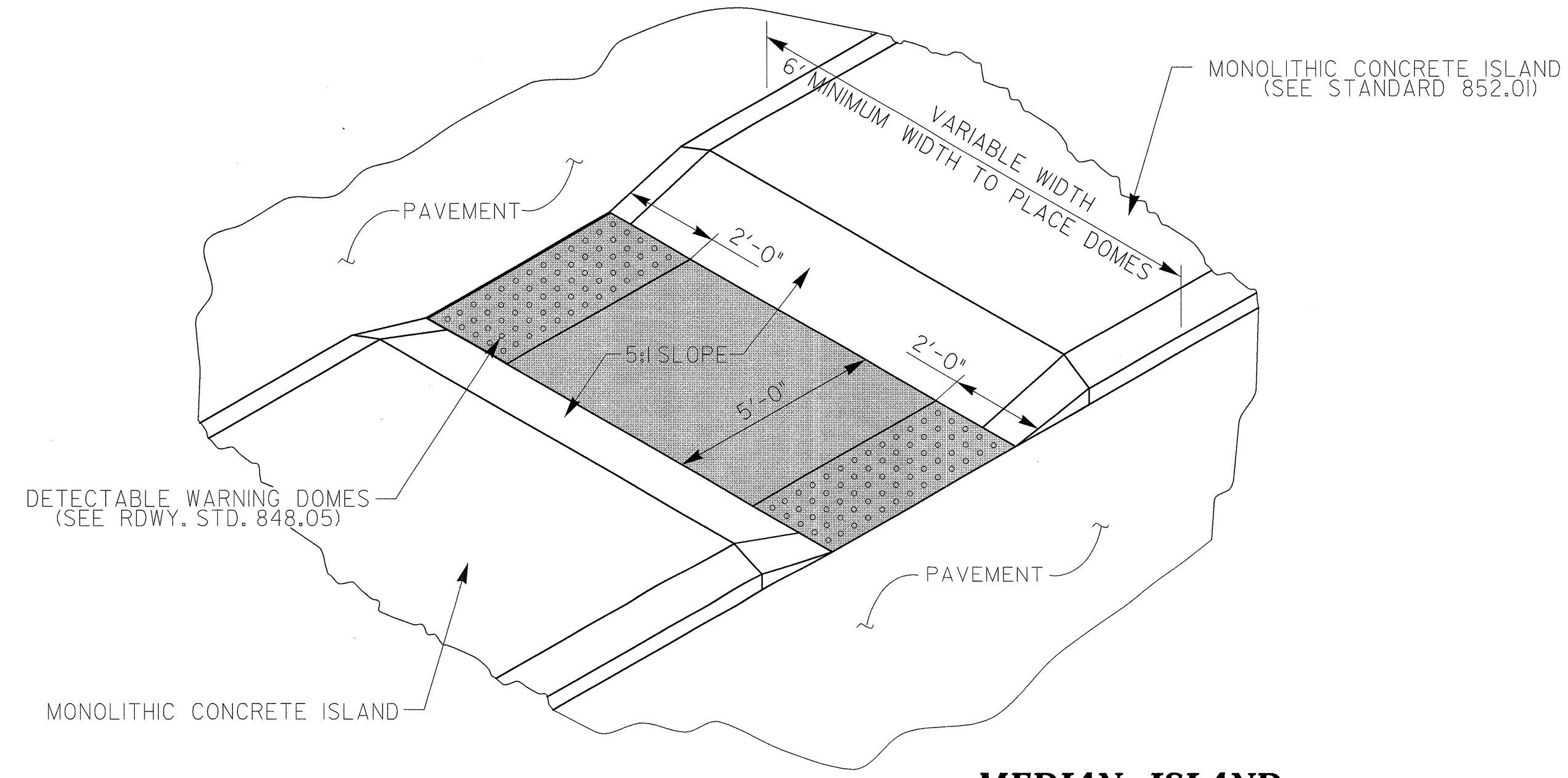

**MEDIAN ISLAND  
WITH CUT THROUGH**

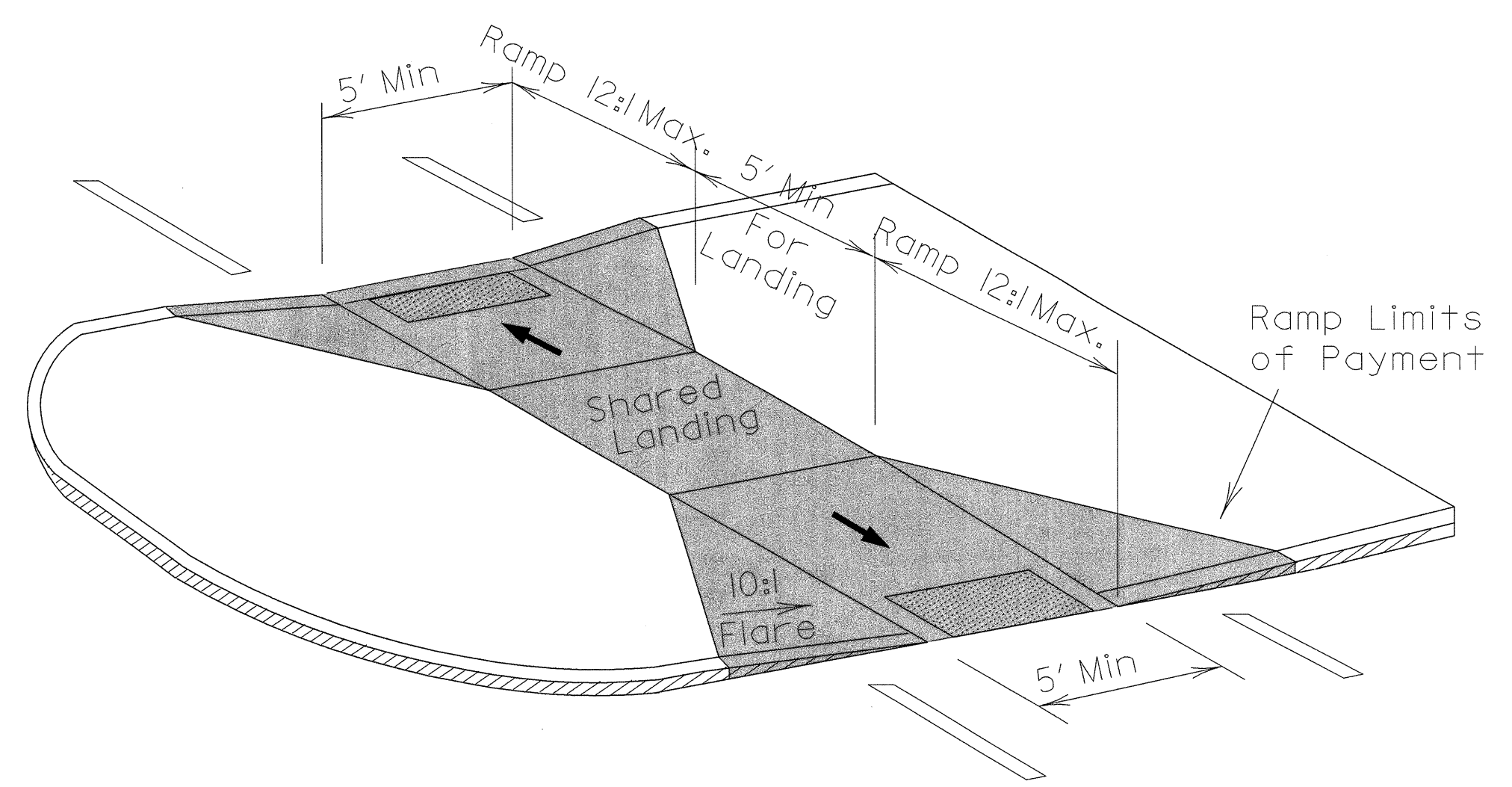

**MEDIAN ISLAND  
CURB RAMPS**



<b>CONTRACT STANDARDS AND DEVELOPMENT UNIT</b>	
Office 919-707-6950 FAX 919-250-4119	
<b>CURB RAMPS</b>	
Median or Turn Lane Islands	
ORIGINAL BY: J.S. HOWERTON	DATE: 7/7/11
MODIFIED BY: _____	DATE: _____
CHECKED BY: _____	DATE: _____
FILE SPEC. :stds/2012CurbRamp/CurbRampDetails.dgn	

DCN 0302DEL\_P12

1/22/02

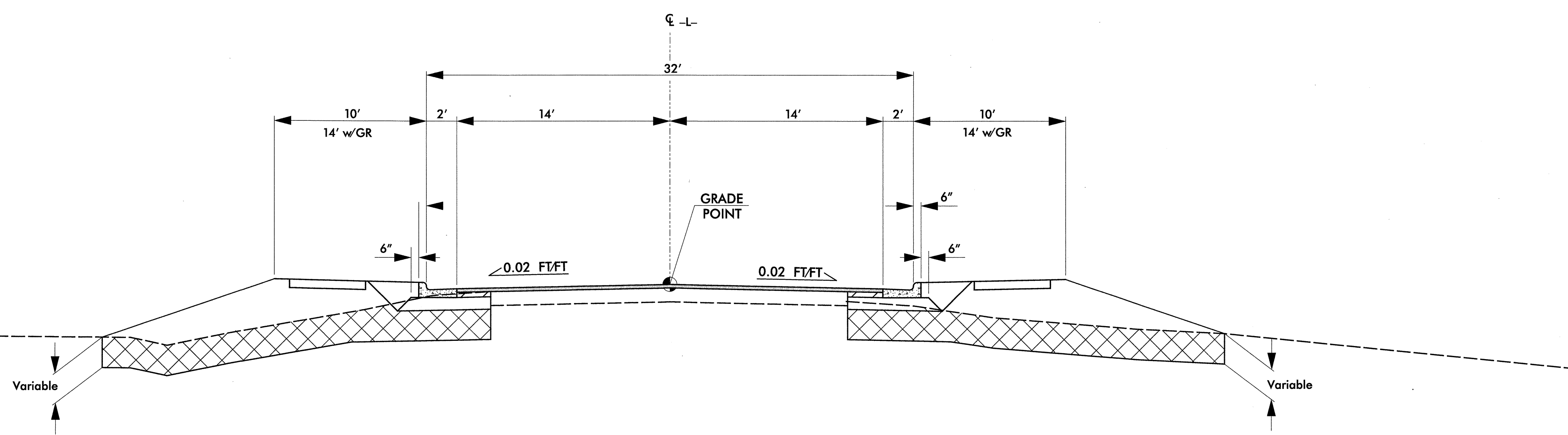

**UNDERCUT DETAIL NO. 1**  
 -L- (Klumac Road)  
 USE UNDERCUT DETAIL NO. 1  
 -L- STA. 10+00.00 TO STA. 13+00.00

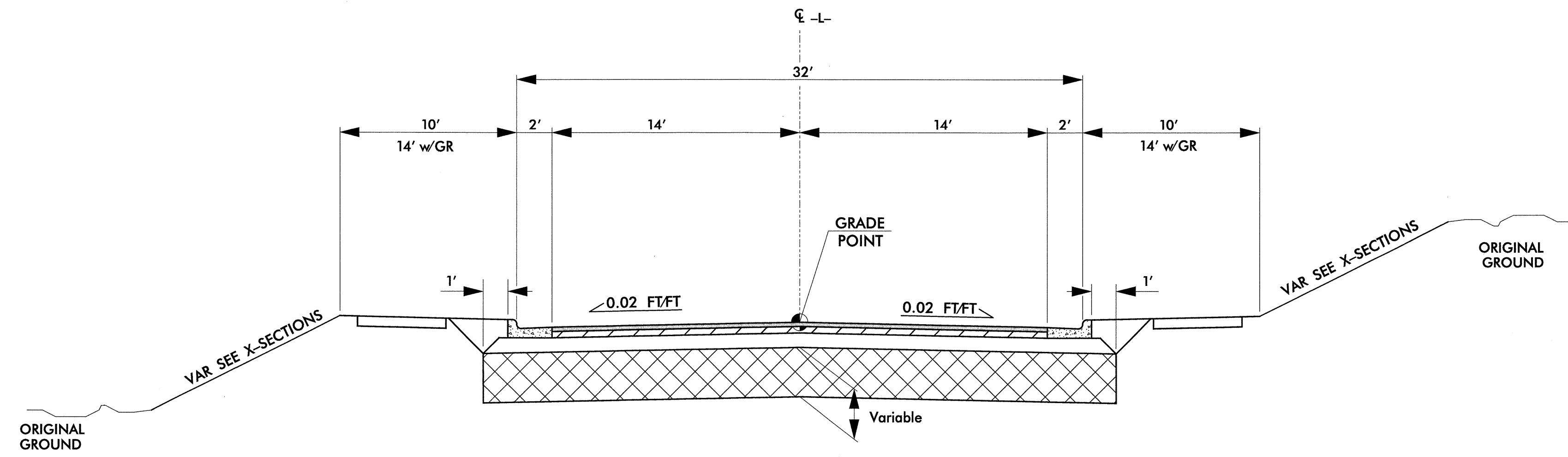

**UNDERCUT DETAIL NO. 2**  
 -L- (Klumac Road)  
 USE UNDERCUT DETAIL NO. 2  
 -L- STA. 31+00.00 TO STA. 38+00.00

PAYMENT DESIGN  
 ENGINEER

Florence & Hutcheson, Inc.  
 9/6/2012  
 R:\Rail-Roadway\Proj\KLUMAC\_Rail\_rdy\_typ.dgn

NO.	BY	DATE	REVISION

ROADWAY DESIGN  
 ENGINEER

NORTH CAROLINA DEPARTMENT OF TRANSPORTATION  
**RAIL DIVISION**

PREPARED BY:  
**ENGINEERING & SAFETY BRANCH**

MAIL: 1056 MAIL SERVICE CENTER RALEIGH, NC 27633-4556  
 DELIVERY: 950 CAPITAL BOULEVARD RALEIGH, NC 27603  
 PHONE: (919) 715-8803  
 FAX: (919) 715-8804

PROJECT TITLE	U-3459 - KLUMAC ROAD		
<b>SHEET 2-E</b>			
<b>ROADWAY UNDERCUT DETAIL SHEET</b>			
LOCATION	KLUMAC ROAD (SR 2541) IN SALISBURY, NC		
DGN BY	BAW	RAILROAD	NORTH CAROLINA RAILROAD/NORFOLK SOUTHERN
DWN BY	YTM	VAL SEC	
CHK BY	BAW	DATE	OCT. 2011
		SCALE	NONE
		MILE POST	MP 335.2
		SHEET	OF

**STATE OF NORTH CAROLINA  
DIVISION OF HIGHWAYS  
ROADWAY SUMMARY OF QUANTITIES FOR CONTRACT - C203127**

ItemNumber	Sec #	Quantity	Unit	Description
0000100000-N	800	Lump Sum		MOBILIZATION
0000400000-N	801	Lump Sum		CONSTRUCTION SURVEYING
0001000000-E	200	Lump Sum		CLEARING & GRUBBING . ACRE(S)
0008000000-E	200	1	ACR	SUPPLEMENTARY CLEARING & GRUB-BING
0022000000-E	225	39,800	CY	UNCLASSIFIED EXCAVATION
0036000000-E	225	4,400	CY	UNDERCUT EXCAVATION
0106000000-E	230	21,200	CY	BORROW EXCAVATION
0134000000-E	240	460	CY	DRAINAGE DITCH EXCAVATION
0141000000-E	240	640	LF	BERM DITCH CONSTRUCTION
0156000000-E	250	3,110	SY	REMOVAL OF EXISTING ASPHALT PAVEMENT
0192000000-N	260	5	HR	PROOF ROLLING
0196000000-E	270	5,500	SY	GEOTEXTILE FOR SOIL STABILIZA-TION
0318000000-E	300	860	TON	FOUNDATION CONDITIONING MATE-RIAL, MINOR STRUCTURES
0320000000-E	300	2,660	SY	FOUNDATION CONDITIONING GEO-TEXTILE
0335200000-E	305	568	LF	15" DRAINAGE PIPE
0335300000-E	305	476	LF	18" DRAINAGE PIPE
0335400000-E	305	448	LF	24" DRAINAGE PIPE
0378000000-E	310	60	LF	24" RC PIPE CULVERTS, CLASS III
0390000000-E	310	252	LF	36" RC PIPE CULVERTS, CLASS III
0448200000-E	310	1,262	LF	15" RC PIPE CULVERTS, CLASS IV
0448300000-E	310	600	LF	18" RC PIPE CULVERTS, CLASS IV
0448400000-E	310	364	LF	24" RC PIPE CULVERTS, CLASS IV
0448500000-E	310	184	LF	30" RC PIPE CULVERTS, CLASS IV
0588000000-E	310	16	LF	18" CS PIPE CULVERTS, 0.064" THICK
0594000000-E	310	140	LF	24" CS PIPE CULVERTS, 0.064" THICK

**SUMMARY OF QUANTITIES - U-3459**

ItemNumber	Sec #	Quantity	Unit	Description
0636000000-E	310	4	EA	*** CS PIPE ELBOWS, ***** THICK (24", 0.064")
0973100000-E	330	46	LF	*** WELDED STEEL PIPE, ***** THICK, GRADE B IN SOIL (36", 0.5")
0973300000-E	330	46	LF	*** WELDED STEEL PIPE, ***** THICK, GRADE B NOT IN SOIL (36", 0.5")
0974000000-E	SP	72	LF	*** WELDED STEEL PIPE, ***** THICK, GRADE B, (UNDER RR) (24", 0.5")
0986000000-E	SP	80	LF	GENERIC PIPE ITEM 18" BIT COAT CS PIPE, 0.079" THICK (UNDER RAILROAD)
0995000000-E	340	807	LF	PIPE REMOVAL
1011000000-N	500	Lump Sum		FINE GRADING
1220000000-E	545	200	TON	INCIDENTAL STONE BASE
1330000000-E	607	1,175	SY	INCIDENTAL MILLING
1489000000-E	610	3,350	TON	ASPHALT CONC BASE COURSE, TYPE B25.0B
1498000000-E	610	2,870	TON	ASPHALT CONC INTERMEDIATE COURSE, TYPE I19.0B
1519000000-E	610	2,540	TON	ASPHALT CONC SURFACE COURSE, TYPE S9.5B
1575000000-E	620	440	TON	ASPHALT BINDER FOR PLANT MIX
1693000000-E	654	400	TON	ASPHALT PLANT MIX, PAVEMENT REPAIR
2000000000-N	806	61	EA	RIGHT OF WAY MARKERS
2022000000-E	815	90	CY	SUBDRAIN EXCAVATION
2033000000-E	815	70	CY	SUBDRAIN FINE AGGREGATE
2044000000-E	815	400	LF	6" PERFORATED SUBDRAIN PIPE
2070000000-N	815	1	EA	SUBDRAIN PIPE OUTLET
2077000000-E	815	6	LF	6" OUTLET PIPE
2209000000-E	838	1.4	CY	ENDWALLS
2253000000-E	840	1.5	CY	PIPE COLLARS
2275000000-E	SP	30	CY	FLOWABLE FILL

ItemNumber	Sec #	Quantity	Unit	Description
2286000000-N	840	63	EA	MASONRY DRAINAGE STRUCTURES
2308000000-E	840	13.9	LF	MASONRY DRAINAGE STRUCTURES
2364000000-N	840	4	EA	FRAME WITH TWO GRATES, STD 840.16
2365000000-N	840	5	EA	FRAME WITH TWO GRATES, STD 840.22
2366000000-N	840	7	EA	FRAME WITH TWO GRATES, STD 840.24
2367000000-N	840	1	EA	FRAME WITH TWO GRATES, STD 840.29
2374000000-N	840	3	EA	FRAME WITH GRATE & HOOD, STD 840.03, TYPE ** (E)
2374000000-N	840	20	EA	FRAME WITH GRATE & HOOD, STD 840.03, TYPE ** (F)
2374000000-N	840	19	EA	FRAME WITH GRATE & HOOD, STD 840.03, TYPE ** (G)
2396000000-N	840	2	EA	FRAME WITH COVER, STD 840.54
2535000000-E	846	240	LF	***X *** CONCRETE CURB (8" X 12")
2542000000-E	846	50	LF	1'-6" CONCRETE CURB & GUTTER
2549000000-E	846	6,760	LF	2'-6" CONCRETE CURB & GUTTER
2591000000-E	848	3,370	SY	4" CONCRETE SIDEWALK
2605000000-N	848	20	EA	CONCRETE CURB RAMP
2612000000-E	848	320	SY	6" CONCRETE DRIVEWAY
2619000000-E	850	130	SY	4" CONCRETE PAVED DITCH
2724000000-E	857	495	LF	PRECAST REINFORCED CONCRETE BARRIER, SINGLE FACED
2830000000-N	858	4	EA	ADJUSTMENT OF MANHOLES
2845000000-N	858	1	EA	ADJUSTMENT OF METER BOXES OR VALVE BOXES
3030000000-E	862	675	LF	STEEL BM GUARDRAIL
3045000000-E	862	162.5	LF	STEEL BM GUARDRAIL, SHOP CURVED
3105000000-N	862	6	EA	STEEL BM GUARDRAIL TERMINAL SECTIONS

ItemNumber	Sec #	Quantity	Unit	Description
3150000000-N	862	10	EA	ADDITIONAL GUARDRAIL POSTS
3270000000-N	SP	3	EA	GUARDRAIL ANCHOR UNITS, TYPE 350
3317000000-N	862	7	EA	GUARDRAIL ANCHOR UNITS, TYPE B-77
3360000000-E	863	160	LF	REMOVE EXISTING GUARDRAIL
3536000000-E	866	276	LF	CHAIN LINK FENCE, 48" FABRIC
3542000000-E	866	24	EA	METAL LINE POSTS FOR 48" CHAIN LINK FENCE
3548000000-E	866	7	EA	METAL TERMINAL POSTS FOR 48" CHAIN LINK FENCE
3649000000-E	876	175	TON	RIP RAP, CLASS B
3656000000-E	876	1,780	SY	GEOTEXTILE FOR DRAINAGE
3659000000-N	SP	1	EA	PREFORMED SCOUR HOLES WITH LEVEL SPREADER APRON
3804000000-E	SP	8,700	TON	AGGREGATE BASE COURSE (SUB-BALLAST)
4025000000-E	901	25	SF	CONTRACTOR FURNISHED, TYPE *** SIGN (D)
4025000000-E	901	157	SF	CONTRACTOR FURNISHED, TYPE *** SIGN (E)
4025000000-E	901	263	SF	CONTRACTOR FURNISHED, TYPE *** SIGN (F)
4072000000-E	903	675	LF	SUPPORTS, 3-LB STEEL U-CHANNEL
4096000000-N	904	2	EA	SIGN ERECTION, TYPE D
4102000000-N	904	20	EA	SIGN ERECTION, TYPE E
4108000000-N	904	12	EA	SIGN ERECTION, TYPE F
4155000000-N	907	16	EA	DISPOSAL OF SIGN SYSTEM, U-CHANNEL
4238000000-N	907	12	EA	DISPOSAL OF SIGN, D, E OR F
4400000000-E	1110	469	SF	WORK ZONE SIGNS (STATIONARY)
4405000000-E	1110	261	SF	WORK ZONE SIGNS (PORTABLE)
4410000000-E	1110	211	SF	WORK ZONE SIGNS (BARRICADE MOUNTED)

ItemNumber	Sec #	Quantity	Unit	Description
4430000000-N	1130	91	EA	DRUMS
4435000000-N	1135	68	EA	CONES
4445000000-E	1145	575	LF	BARRICADES (TYPE III)
4450000000-N	1150	624	HR	FLAGGER
4465000000-N	1160	2	EA	TEMPORARY CRASH CUSHIONS
4485000000-E	1170	620	LF	PORTABLE CONCRETE BARRIER
4516000000-N	1180	30	EA	SKINNY DRUM
4685000000-E	1205	721	LF	THERMOPLASTIC PAVEMENT MARKING LINES (4", 90 MILS)
4686000000-E	1205	9,943	LF	THERMOPLASTIC PAVEMENT MARKING LINES (4", 120 MILS)
4695000000-E	1205	430	LF	THERMOPLASTIC PAVEMENT MARKING LINES (8", 90 MILS)
4710000000-E	1205	294	LF	THERMOPLASTIC PAVEMENT MARKING LINES (24", 120 MILS)
4725000000-E	1205	18	EA	THERMOPLASTIC PAVEMENT MARKING SYMBOL (90 MILS)
4810000000-E	1205	30,176	LF	PAINT PAVEMENT MARKING LINES (4")
4815000000-E	1205	598	LF	PAINT PAVEMENT MARKING LINES (6")
4835000000-E	1205	2,298	LF	PAINT PAVEMENT MARKING LINES (24")
4845000000-N	1205	9	EA	PAINT PAVEMENT MARKING SYMBOL
4870000000-E	1205	137	LF	REMOVAL OF PAVEMENT MARKING LINES (24")
4900000000-N	1251	164	EA	PERMANENT RAISED PAVEMENT MARKERS
4915000000-E	1264	3	EA	7' U-CHANNEL POSTS
4955000000-N	1264	3	EA	OBJECT MARKERS (END OF ROAD)
5325600000-E	1510	659	LF	6" WATER LINE
5325800000-E	1510	67	LF	8" WATER LINE
5326200000-E	1510	112	LF	12" WATER LINE
5540000000-E	1515	2	EA	6" VALVE
5558000000-E	1515	2	EA	12" VALVE

ItemNumber	Sec #	Quantity	Unit	Description
5660000000-E	1515	2	EA	2" BLOW OFF
5648000000-N	1515	4	EA	RELOCATE WATER METER
5672000000-N	1515	1	EA	RELOCATE FIRE HYDRANT
5691300000-E	1520	2,607	LF	8" SANITARY GRAVITY SEWER
5775000000-E	1525	10	EA	4' DIA UTILITY MANHOLE
5776000000-E	1525	4	EA	5' DIA UTILITY MANHOLE
5781000000-E	1525	2.79	LF	UTILITY MANHOLE WALL, 4' DIA
5782000000-E	1525	14.64	LF	UTILITY MANHOLE WALL, 5' DIA
5800000000-E	1530	532	LF	ABANDON 6" UTILITY PIPE
5801000000-E	1530	1,102	LF	ABANDON 8" UTILITY PIPE
5804000000-E	1530	309	LF	ABANDON 12" UTILITY PIPE
5815500000-N	1530	1	EA	REMOVE FIRE HYDRANT
5816000000-N	1530	1	EA	ABANDON UTILITY MANHOLE
5828000000-N	1530	2	EA	REMOVE UTILITY MANHOLE
5835700000-E	1540	76	LF	16" ENCASEMENT PIPE
5835800000-E	1540	162	LF	18" ENCASEMENT PIPE
5872000000-E	1550	40	LF	TRENCHLESS INSTALLATION OF 18" IN SOIL
5872010000-E	1550	40	LF	TRENCHLESS INSTALLATION OF 18" NOT IN SOIL
6000000000-E	1605	18,210	LF	TEMPORARY SILT FENCE
6006000000-E	1610	345	TON	STONE FOR EROSION CONTROL, CLASS A
6009000000-E	1610	3,095	TON	STONE FOR EROSION CONTROL, CLASS B
6012000000-E	1610	1,760	TON	SEDIMENT CONTROL STONE
6015000000-E	1615	24	ACR	TEMPORARY MULCHING
6018000000-E	1620	500	LB	SEED FOR TEMPORARY SEEDING
6021000000-E	1620	3	TON	FERTILIZER FOR TEMPORARY SEED-ING
6024000000-E	1622	793	LF	TEMPORARY SLOPE DRAINS
6030000000-E	1630	5,610	CY	SILT EXCAVATION



SUMMARY OF QUANTITIES - U-3459

ItemNumber	Sec #	Quantity	Unit	Description
603600000-E	1631	18,850	SY	MATTING FOR EROSION CONTROL
603700000-E	SP	60	SY	COIR FIBER MAT
603800000-E	SP	1,575	SY	PERMANENT SOIL REINFORCEMENT MAT
604200000-E	1632	3,900	LF	1/4" HARDWARE CLOTH
607000000-N	1639	4	EA	SPECIAL STILLING BASINS
6071012000-E	SP	1,975	LF	COIR FIBER WATTLE
6071020000-E	SP	865	LB	POLYACRYLAMIDE (PAM)
6071030000-E	1640	905	LF	COIR FIBER BAFFLE
6071050000-E	SP	4	EA	*** SKIMMER (1-1/2")
608400000-E	1660	15	ACR	SEEDING & MULCHING
608700000-E	1660	18	ACR	MOWING
609000000-E	1661	250	LB	SEED FOR REPAIR SEEDING
609300000-E	1661	0.75	TON	FERTILIZER FOR REPAIR SEEDING
609600000-E	1662	350	LB	SEED FOR SUPPLEMENTAL SEEDING
610800000-E	1665	11	TON	FERTILIZER TOPDRESSING
611450000-N	1667	10	MHR	SPECIALIZED HAND MOWING
611700000-N	SP	150	EA	RESPONSE FOR EROSION CONTROL
706000000-E	1705	2,300	LF	SIGNAL CABLE
712000000-E	1705	21	EA	VEHICLE SIGNAL HEAD (12", 3 SECTION)
713200000-E	1705	2	EA	VEHICLE SIGNAL HEAD (12", 4 SECTION)
725200000-E	1710	1,050	LF	MESSENGER CABLE (1/4")
726400000-E	1710	960	LF	MESSENGER CABLE (3/8")
727900000-E	1715	3,525	LF	TRACER WIRE
730000000-E	1715	3,470	LF	UNPAVED TRENCHING (*****) (1, 2")
730010000-E	1715	30	LF	UNPAVED TRENCHING FOR TEMPORARY LEAD-IN
730100000-E	1715	500	LF	DIRECTIONAL DRILL (*****) (1, 2")

ItemNumber	Sec #	Quantity	Unit	Description
732400000-N	1716	10	EA	JUNCTION BOX (STANDARD SIZE)
734800000-N	1716	11	EA	JUNCTION BOX (OVER-SIZED, HEAVY DUTY)
736000000-N	1720	7	EA	WOOD POLE
737200000-N	1721	18	EA	GUY ASSEMBLY
739600000-E	1722	2	EA	1/2" RISER WITH WEATHERHEAD
740800000-E	1722	2	EA	1" RISER WITH WEATHERHEAD
742000000-E	1722	10	EA	2" RISER WITH WEATHERHEAD
744400000-E	1725	1,400	LF	INDUCTIVE LOOP SAWCUT
745600000-E	1726	4,150	LF	LEAD-IN CABLE (*****) (14-2)
751600000-E	1730	3,650	LF	COMMUNICATIONS CABLE (**FIBER) (12)
752800000-E	1730	1,100	LF	DROP CABLE
754000000-N	1731	2	EA	SPLICE ENCLOSURE
755200000-N	1731	1	EA	INTERCONNECT CENTER
756600000-N	1733	4	EA	DELINEATOR MARKER
756800000-N	SP	1	EA	FURNISH FIBER-OPTIC RESTORATION KIT
757000000-N	SP	1	EA	FURNISH FIBER-OPTIC POWER METER
757200000-N	SP	1	EA	FURNISH OPTICAL LIGHT GENERATOR
7575160000-E	1734	1,000	LF	REMOVE EXISTING COMMUNICATIONS CABLE
7575180000-N	1735	7	EA	CABLE TRANSFER
757600000-N	SP	2	EA	METAL STRAIN SIGNAL POLE
761300000-N	SP	2	EA	SOIL TEST
761410000-E	SP	16	CY	DRILLED PIER FOUNDATION
763600000-N	1745	2	EA	SIGN FOR SIGNALS
764220000-N	1743	1	EA	TYPE II PEDESTAL WITH FOUNDATION
768400000-N	1750	2	EA	SIGNAL CABINET FOUNDATION

ItemNumber	Sec #	Quantity	Unit	Description
775600000-N	1751	1	EA	CONTROLLER WITH CABINET (TYPE 2070L, BASE MOUNTED)
778000000-N	1751	6	EA	DETECTOR CARD (TYPE 2070L)
782800000-N	1751	1	EA	CONTROLLER WITH CABINET (NEMA TS-2, TYPE 2 CONTROLLER, TYPE 1 CABINET, BASE MOUNTED)
785200000-N	1751	6	EA	DETECTOR CARD (NEMA TS-2)
790100000-N	1753	1	EA	CABINET BASE EXTENDER
794800000-N	1757	1	EA	TRAFFIC SIGNAL REMOVAL









# SUMMARY OF EARTHWORK IN CUBIC YARDS

LOCATION	UNCLASSIFIED EXCAVATION	UNDERCUT	EMBT + %	BORROW	WASTE
<b>DETOUR TRACK CONSTRUCTION</b>					
-MAIN2DET- 8903 + 83.98 TO -MAIN2DET- 8904 + 50.00	0		109	109	0
-MAINIDET- 8904 + 50.00 TO -MAINIDET- 8929 + 00.00	749	185	14,609	13,860	185
-MAINIDET- 8929 + 00.00 TO -MAIN2DET- 8929 + 42.73	3		1	0	2
SUBTOTAL NO. 1	752	185	14,719	13,969	187
<b>ROADWAY CONSTRUCTION</b>					
-L- 10 + 50.00 TO -L- 31 + 00.00	3,237	964	26,297	23,060	964
<b>CONTAMINATED SOIL REMOVED BY OTHERS</b>					
-Y1- 10 + 14.00 TO -Y1- 12 + 25.00	401		232	0	169
-Y4- 13 + 05.00 TO -Y4- 14 + 26.96	7		379	372	0
-Y4- 14 + 68.84 TO -Y4- 15 + 90.00	20		272	252	0
SUBTOTAL NO. 2	3,265	964	27,180	23,694	733
<b>CONTAMINATED SOIL REMOVED BY OTHERS</b>					
-L- 31 + 00.00 TO -L- 40 + 12.00	22,312	2,210	2,845	0	21,677
<b>CONTAMINATED SOIL REMOVED BY OTHERS</b>					
-Y2- 11 + 45.00 TO -Y2- 14 + 65.00	178		17	0	161
SUBTOTAL NO. 3	19,890	2,210	2,862	0	19,238
<b>MAIN TRACK CONSTRUCTION</b>					
-MAIN1- 8904 + 37.69 TO -MAIN1- 8915 + 87.44 (BEG. BR.)	1,477		490	0	987
-MAIN1- 8917 + 34.13 (END BR.) TO -MAIN1- 8928 + 90.78	1,419		463	0	956
SUBTOTAL NO. 4	2,896		953	0	1,943
<b>DETOUR REMOVAL</b>					
-MAIN1- 8909 + 00 TO -MAIN2- 8922 + 50	12,987		319	0	12,668
SUBTOTAL NO. 5	12,987		319	0	12,668
<b>TOTAL DETOUR CONSTRUCTION</b>					
WASTE IN LIEU OF BORROW	752		14,497	13,747	2
<b>TOTAL CONSTRUCTION (SUBTOTAL #2 THRU #4)</b>					
ADDITIONAL UNDERCUT	26,051	3,174	30,995	23,684	21,914
LOSS DUE TO CLEARING & GRUBBING		1,000	1,200	1,200	1,000
WASTE IN LIEU OF BORROW				-18,740	-18,740
<b>TOTAL DETOUR REMOVAL</b>					
	12,987		319		12,668
<b>TOTAL</b>					
	39,790	4,359	47,233	20,111	17,027
<b>PROJECT TOTAL</b>					
EST. 5% TO REPLACE TOP SOIL ON BORROW PIT				1,006	
	39,790	4,359	47,233	20,111	17,027
<b>GRAND TOTAL</b>					
SAY	39,800	4,400		21,200	

NO.	BY	DATE	REVISION

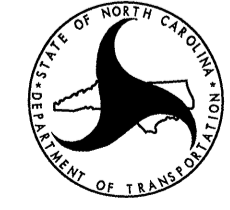
 <p>NORTH CAROLINA DEPARTMENT OF TRANSPORTATION <b>RAIL DIVISION</b></p>	PROJECT U-3459 - KLUMAC ROAD TITLE
	<b>SHEET 3-E EARTHWORK SUMMARY</b>
PREPARED BY: <b>ENGINEERING &amp; SAFETY BRANCH</b> <small>MAIL: 1055 MAIL SERVICE CENTER RALEIGH, NC 27689-1556                  DELIVERY: 850 CAPITAL BOULEVARD RALEIGH, NC 27603                  PHONE: (919) 715-8803 FAX: (919) 715-8804</small>	LOCATION KLUMAC ROAD (SR 2541) IN SALISBURY, NC DGN BY BAW DWN BY YTM CHK BY BAW
RAILROAD NORTH CAROLINA RAILROAD/NORFOLK SOUTHERN VAL SEC DATE OCT. 2011	MILE POST MP 335.2 SCALE NONE
<b>SHEET OF</b>	







0302DEL\_P12  
 1/22/02

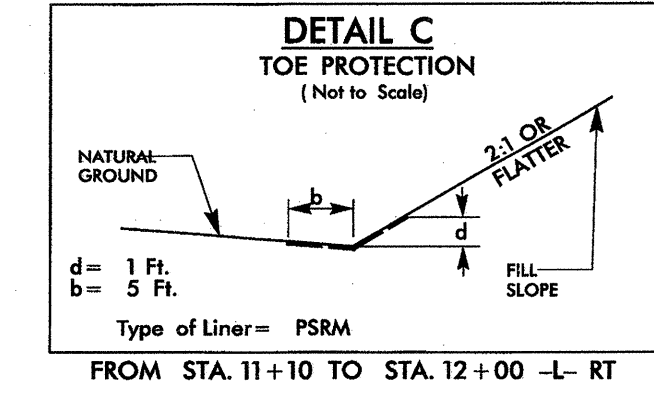
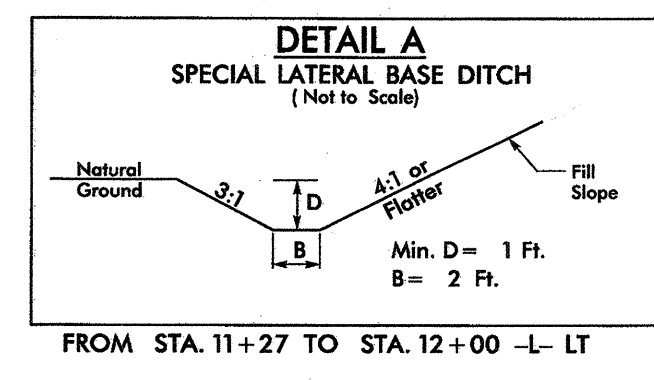

-L-  
 PI Sta 12+76.84  
 $\Delta = 2' 31' 33.2''$  (LT)  
 $D = 1' 08' 45.3''$   
 $L = 220.43'$   
 $T = 110.23'$   
 $R = 5,000.00'$   
 $SE = N/C$

NAD 83/NSRS 2007

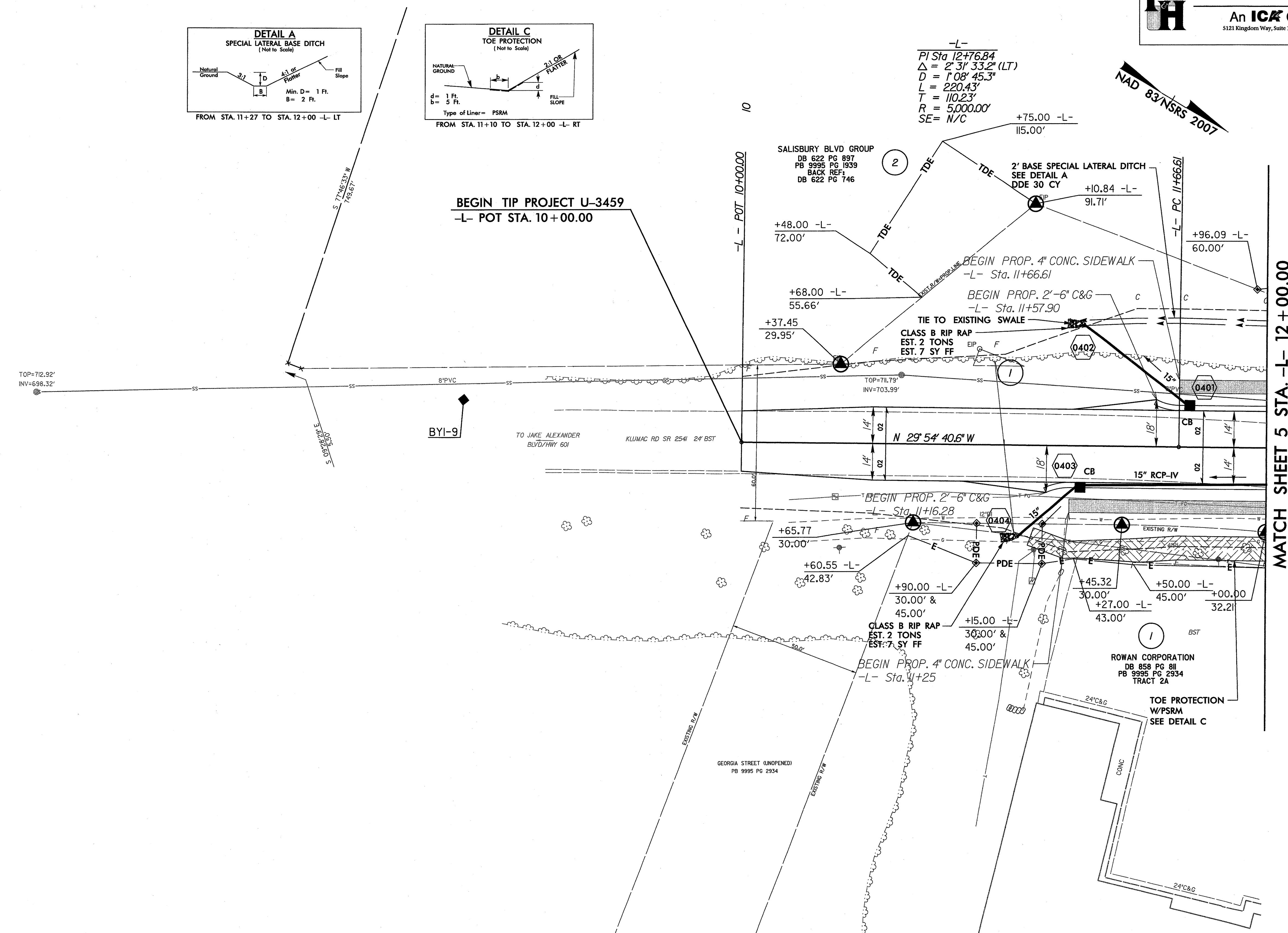

MATCH SHEET 5 STA. -L- 12 + 00.00

FOR -L- PROFILE SEE SHEET 13

				ROADWAY DESIGN ENGINEER 	HYDRAULIC ENGINEER 	NORTH CAROLINA DEPARTMENT OF TRANSPORTATION <b>RAIL DIVISION</b> PREPARED BY: <b>ENGINEERING &amp; SAFETY BRANCH</b> <small>MAIL: 1259 MAIL SERVICE CENTER, RALEIGH, NC 27689-1556                  DELIVERY: 180 CAPITAL BOULEVARD, RALEIGH, NC 27603                  PHONE: (919) 715-8803                  FAX: (919) 715-8804</small>	PROJECT: U-3459 - KLUMAC ROAD TITLE: <b>PLAN SHEET 4</b> LOCATION: KLUMAC ROAD (SR 2541) IN SALISBURY, NC DGN BY: BAW RAILROAD: NORTH CAROLINA RAILROAD/NORFOLK SOUTHERN MILE POST: MP 335.2 DWN BY: YTM VAL SEC: CHK BY: BAW DATE: OCT. 2011 SCALE:	SHEET OF																			
<table border="1" style="width: 100%; border-collapse: collapse;"> <thead> <tr> <th style="width: 5%;">NO.</th> <th style="width: 5%;">BY</th> <th style="width: 10%;">DATE</th> <th style="width: 80%;">REVISION</th> </tr> </thead> <tbody> <tr><td> </td><td> </td><td> </td><td> </td></tr> <tr><td> </td><td> </td><td> </td><td> </td></tr> <tr><td> </td><td> </td><td> </td><td> </td></tr> <tr><td> </td><td> </td><td> </td><td> </td></tr> </tbody> </table>	NO.	BY	DATE	REVISION																							
NO.	BY	DATE	REVISION																								

Florence & Hutcheson, Inc.  
 7/17/2012  
 R:\Rail-Roadway\Proj\KLUMAC\_Rail\_psh04.dgn

0302DEL\_P12

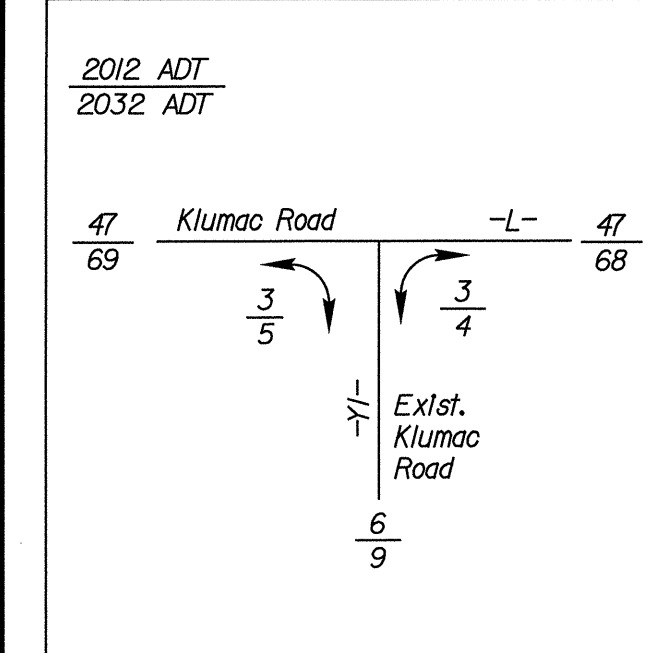

-L-  
 PI Sta 12+76.84  
 $\Delta = 2' 31'' 33.2''$  (LT)  
 $D = 1' 08'' 45.3''$   
 $L = 220.43'$   
 $T = 110.23'$   
 $R = 5,000.00'$   
 $SE = N/C$

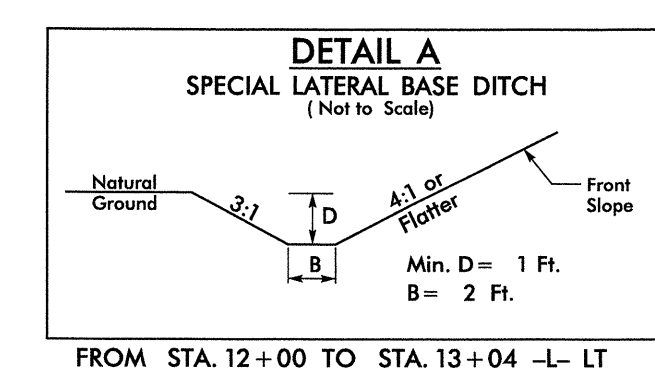

SALISBURY BLVD GROUP  
 DB 622 PG 897  
 PB 9995 PG 1939  
 BACK REF:  
 DB 622 PG 746

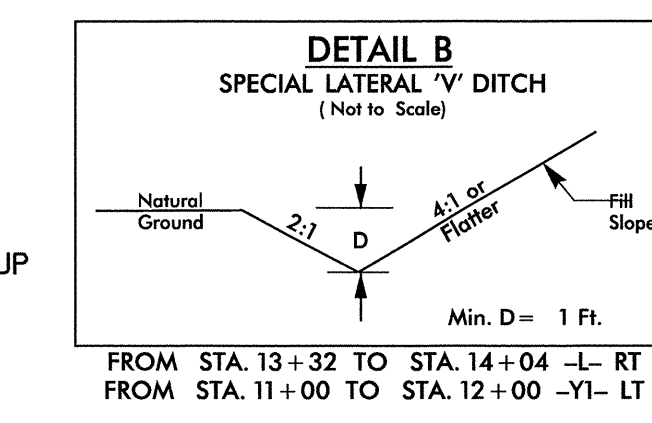

-YI-  
 PI Sta 11+11.23  
 $\Delta = 66' 54'' 57.9''$  (LT)  
 $D = 45' 50'' 11.8''$   
 $L = 145.99'$   
 $T = 82.60'$   
 $R = 125.00'$

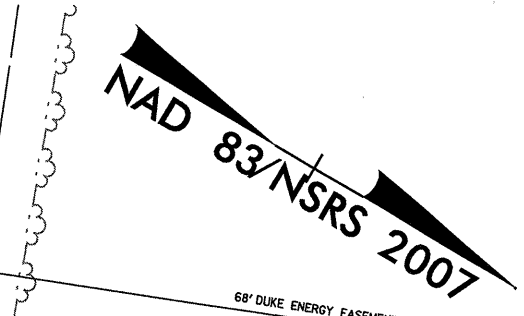

MATCH SHEET 4 STA. -L- 12 + 00.00

MATCH SHEET 6 STA. -L- 17 + 00.00

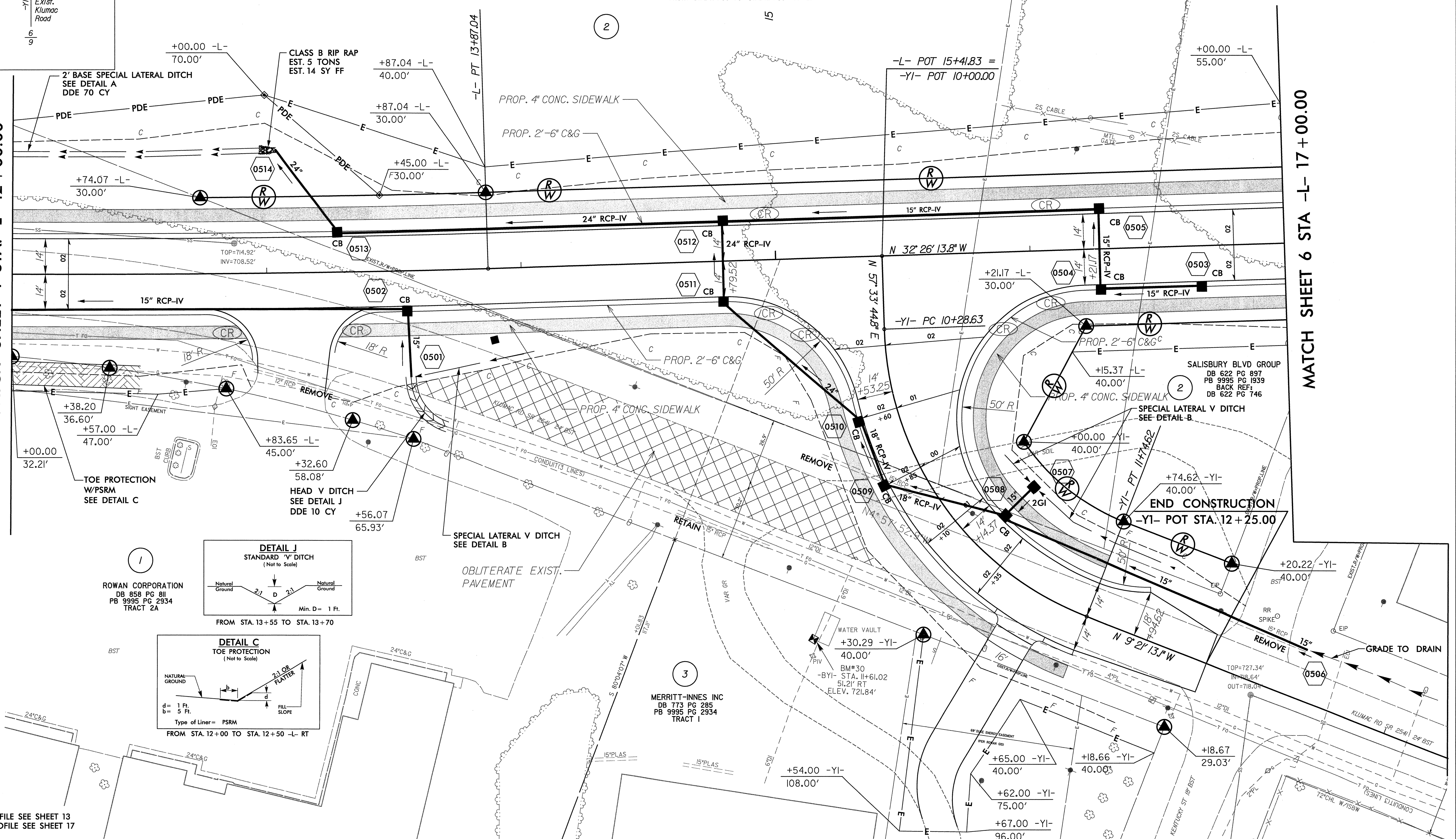

ROWAN CORPORATION  
 DB 858 PG 811  
 PB 9995 PG 2934  
 TRACT 2A

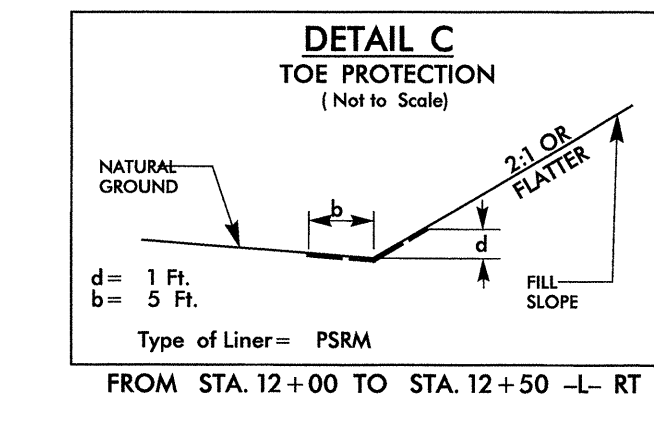
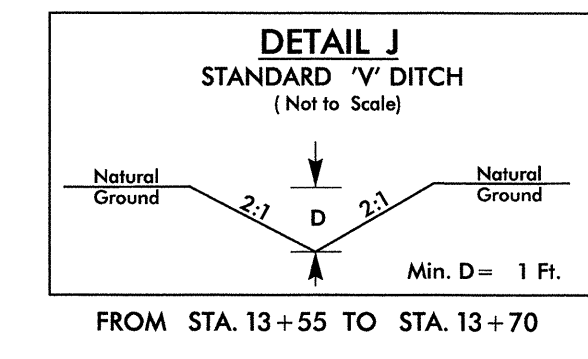

FOR -L- PROFILE SEE SHEET 13  
 FOR -YI- PROFILE SEE SHEET 17

Florence & Hutcheson, Inc. 8/7/2012 R:\Rail-Roadway\Proj\Klunac\_Rail\_psh05.dgn

				NORTH CAROLINA DEPARTMENT OF TRANSPORTATION <b>RAIL DIVISION</b>		PROJECT U-3459 - KLUMAC ROAD TITLE PLAN SHEET 5	
ROADWAY DESIGN ENGINEER ROBERT ALLEN WILES 7/17/12		HYDRAULIC ENGINEER STACY H. BAILEY 7/17/12		PREPARED BY: ENGINEERING & SAFETY BRANCH MAIL: 1556 MAIL SERVICE CENTER RALEIGH, NC 27699-1556 DELIVER: 180 CAPITAL BOULEVARD RALEIGH, NC 27603 PHONE: (919) 715-8803 FAX: (919) 715-8804		LOCATION KLUMAC ROAD (SR 2541) IN SALISBURY, NC DGN BY BAW RAILROAD NORTH CAROLINA RAILROAD/NORFOLK SOUTHERN MILE POST MP 335.2 DWN BY YTM VAL SEC CHK BY BAW DATE OCT. 2011 SCALE SHEET OF	
NO.	BY	DATE	REVISION				

0302DEL\_P12

1/22/02

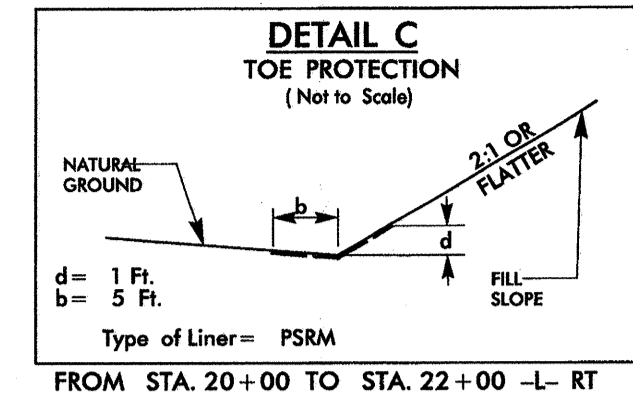
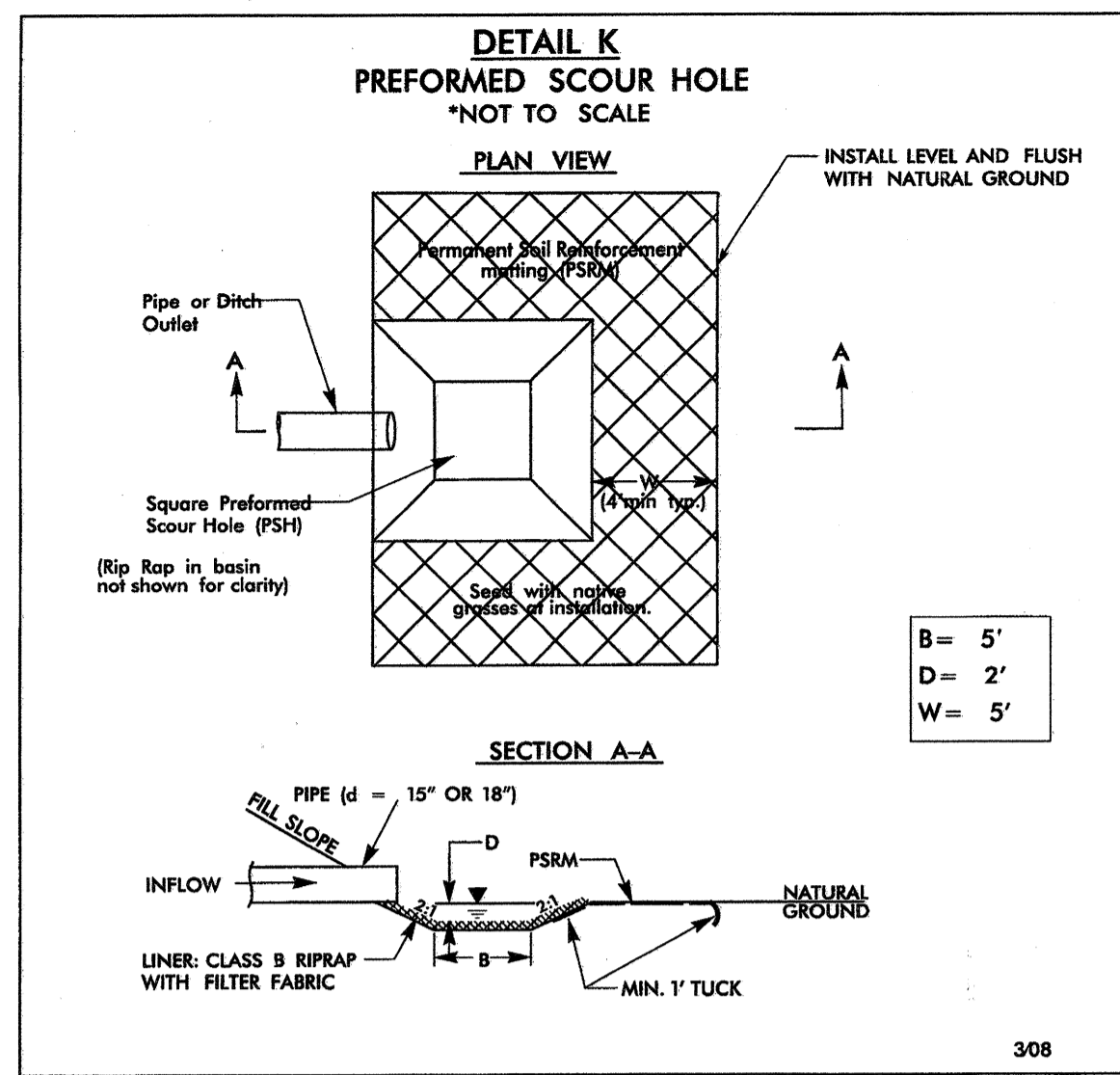

NAD 83/NSRS 2007

-L-  
 PI Sta 20+00.50  
 $\Delta = 5^\circ 42' 18.4''$  (RT)  
 $D = 1' 08'' 45.3''$   
 $L = 497.87'$   
 $T = 249.14'$   
 $R = 5,000.00'$   
 $SE = N/C$

MATCH SHEET 5 STA -L- 17 + 00.00

MATCH SHEET 7 STA. -L- 22 + 00.00

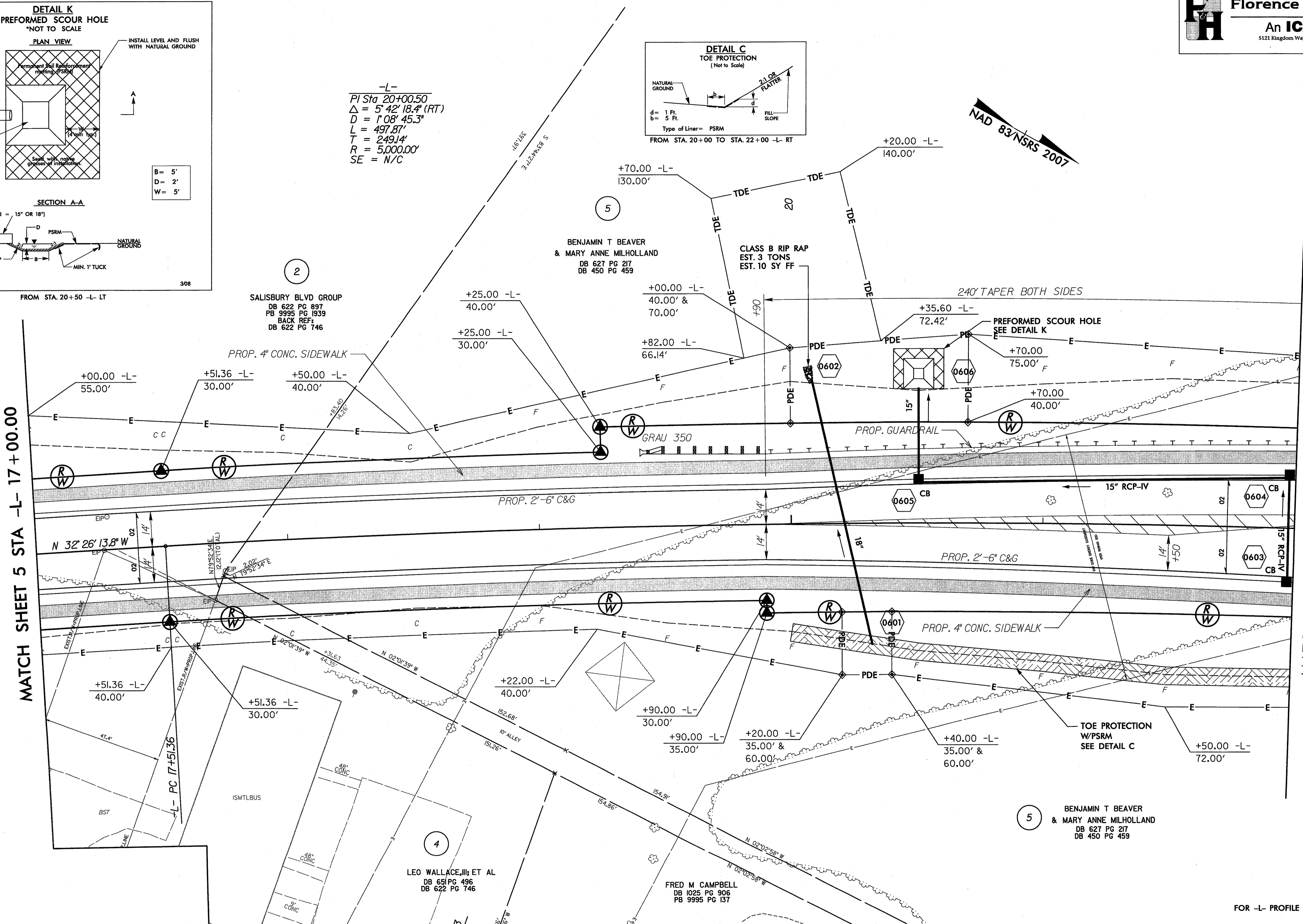

5 BENJAMIN T BEAVER & MARY ANNE MILHOLLAND  
 DB 627 PG 217  
 DB 450 PG 459

4 LEO WALLACE, III ET AL  
 DB 65 PG 496  
 DB 622 PG 746

FRED M CAMPBELL  
 DB 1025 PG 906  
 PB 9995 PG 137

FOR -L- PROFILE SEE SHEET 14

Florence & Hutcheson, Inc.  
 7/17/2012  
 R:\Rail-Roadway\Proj\Klumac\_Rail.psh06.dgn

NO.	BY	DATE	REVISION

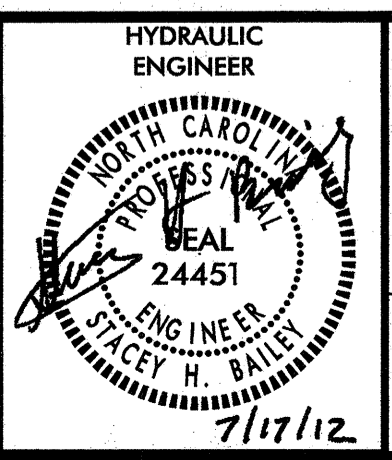
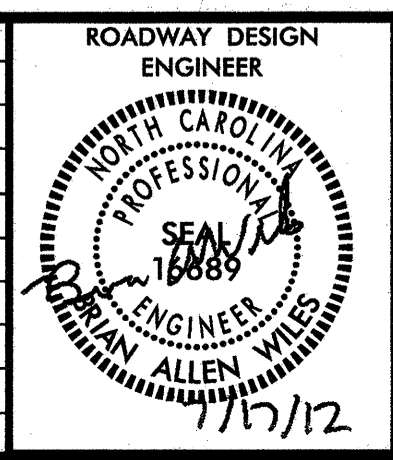

ROADWAY DESIGN ENGINEER

HYDRAULIC ENGINEER

NORTH CAROLINA DEPARTMENT OF TRANSPORTATION  
**RAIL DIVISION**

ENGINEERING & SAFETY BRANCH

PREPARED BY: [Signature]

MAIL: 1556 MAIL SERVICE CENTER DELIVERY: 860 CAPITAL BOULEVARD PHONE: (919) 715-8803  
 RALEIGH, NC 27699-1556 RALEIGH, NC 27603 FAX: (919) 715-8804

PROJECT	U-3459 - KLUMAC ROAD		
TITLE	PLAN SHEET 6		
LOCATION	KLUMAC ROAD (SR 2541) IN SALISBURY, NC		
DGN BY	BAW	RAILROAD	MILE POST MP 335.2
DWN BY	YTM	VAL SEC	NORTH CAROLINA RAILROAD/NORFOLK SOUTHERN
CHK BY	BAW	DATE	OCT. 2011
SCALE			SHEET OF

0302DEL\_P12  
 1/22/02

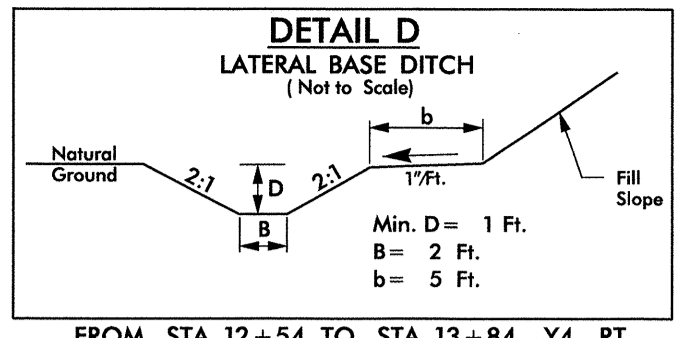
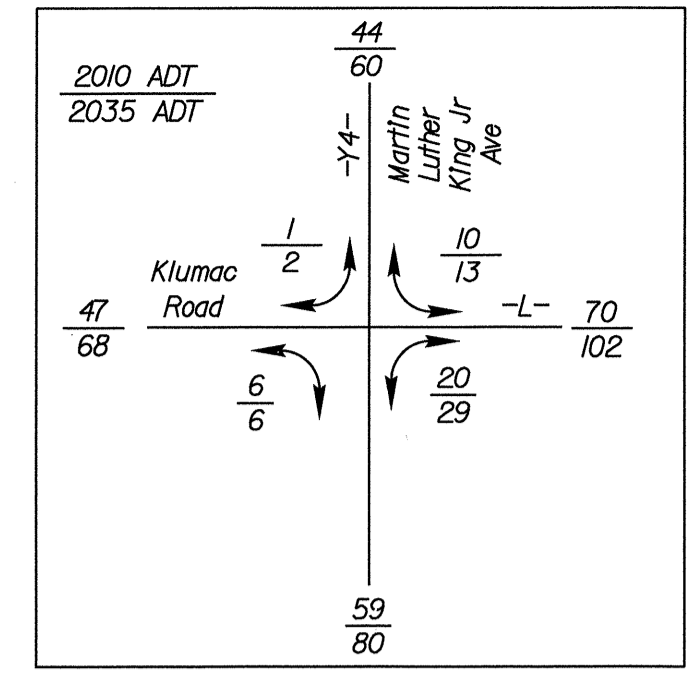

FROM STA. 12+54 TO STA. 13+84 -Y4- RT  
 PI Sta 20+00.50  
 $\Delta = 5' 42'' 18.4'' (RT)$   
 $D = 1' 08'' 45.3''$   
 $L = 497.87'$   
 $T = 249.14'$   
 $R = 5,000.00'$   
 $SE = N/C$

-Y4-  
 PI Sta 11+80.57  
 $\Delta = 9' 53'' 01.8'' (RT)$   
 $D = 3' 05'' 49.4''$   
 $L = 319.14'$   
 $T = 159.96'$   
 $R = 1,850.00'$

TRANSITION PROP. GUARDRAIL TO TIE TO EXIST. GUARDRAIL

MATCH SHEET 6 STA. -L- 22+00.00

MATCH SHEET 8 STA. -L- 27+00.00

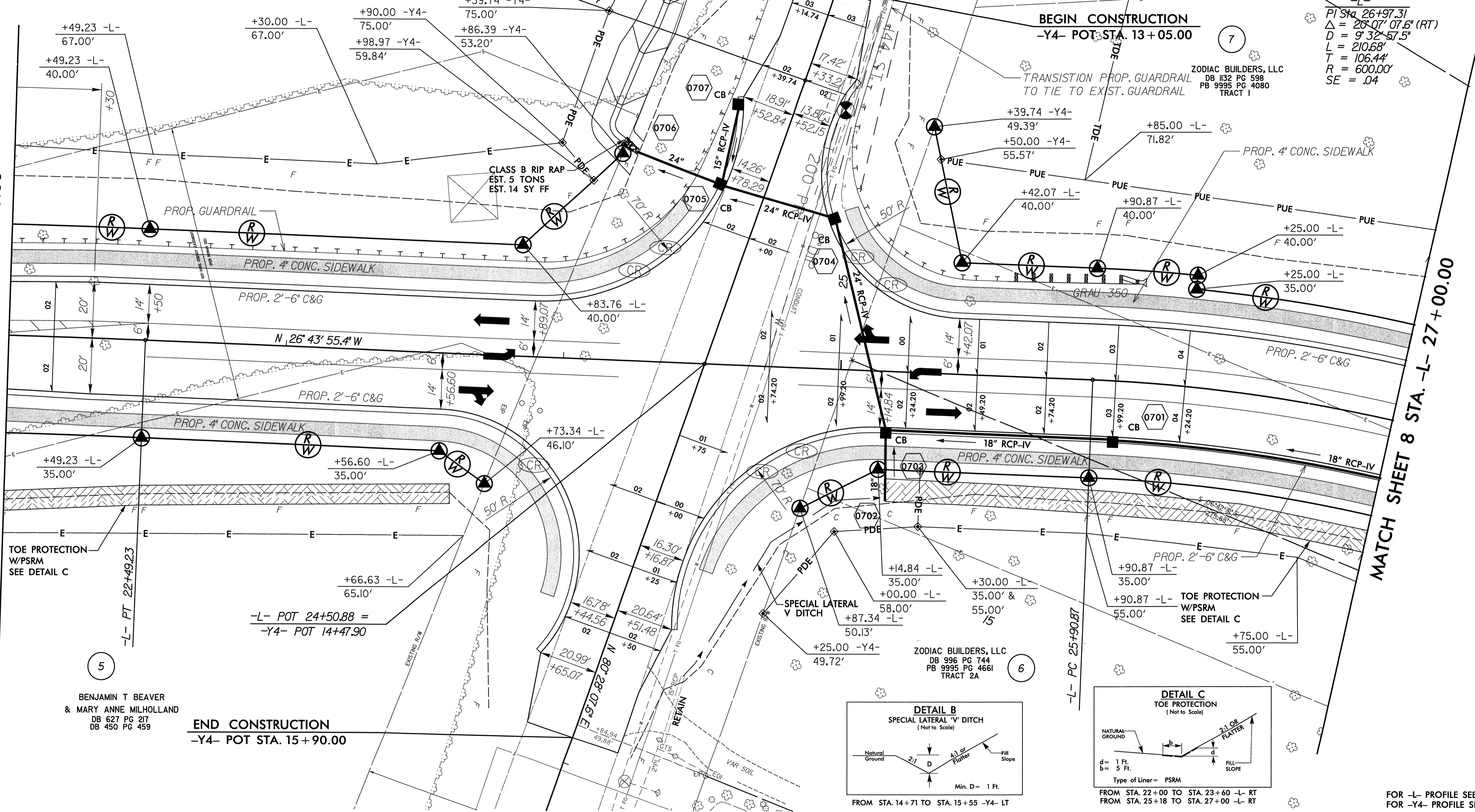

BENJAMIN T BEAVER & MARY ANNE MILHOLLAND  
 DB 627 PG 217  
 DB 450 PG 459

ZODIAC BUILDERS, LLC  
 DB 132 PG 598  
 PB 9995 PG 4080  
 TRACT 1

ZODIAC BUILDERS, LLC  
 DB 996 PG 744  
 PB 9995 PG 4661  
 TRACT 2A

BENJAMIN T BEAVER & MARY ANNE MILHOLLAND  
 DB 627 PG 217  
 DB 450 PG 459

END CONSTRUCTION  
 -Y4- POT STA. 15+90.00

BEGIN CONSTRUCTION  
 -Y4- POT STA. 13+05.00

ZODIAC BUILDERS, LLC  
 DB 132 PG 598  
 PB 9995 PG 4080  
 TRACT 1

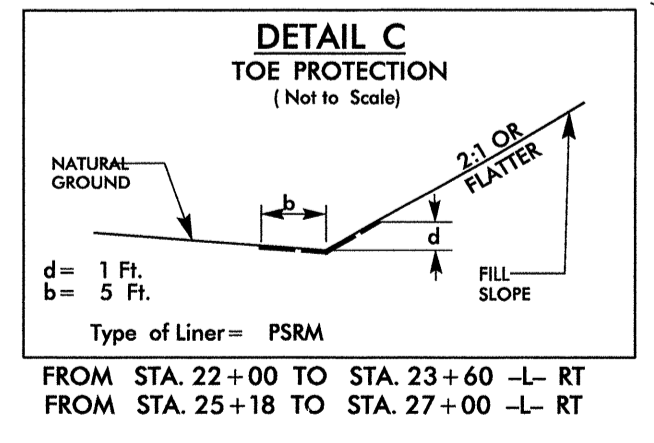
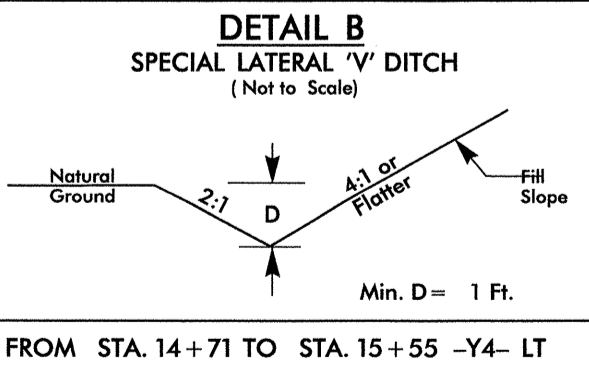

REVISIONS

Florence & Hutcheson, Inc.  
 8/1/2012  
 R:\Rail-Roadway\Proj\Klumac\_Rail\_psh07.dgn

NO.	BY	DATE	REVISION

ROADWAY DESIGN ENGINEER  
 NORTH CAROLINA PROFESSIONAL SEAL  
 10689  
 BRADY ALLEN WILES  
 8/1/12

HYDRAULIC ENGINEER  
 NORTH CAROLINA PROFESSIONAL SEAL  
 74451  
 STEVEY H. BAILEY  
 8/1/12

NORTH CAROLINA DEPARTMENT OF TRANSPORTATION  
**RAIL DIVISION**

PREPARED BY: **ENGINEERING & SAFETY BRANCH**

MAIL: 1956 MAIL SERVICE CENTER RALEIGH, NC 27699-1556  
 DELIVERY: 850 CAPITAL BOULEVARD RALEIGH, NC 27603  
 PHONE: (919) 715-8803  
 FAX: (919) 715-8804

PROJECT TITLE: U-3459 - KLUMAC ROAD  
 PLAN SHEET 7

LOCATION: KLUMAC ROAD (SR 2541) IN SALISBURY, NC

DGN BY: BAW  
 DWN BY: YTM  
 CHK BY: BAW

RAILROAD: NORTH CAROLINA RAILROAD/NORFOLK SOUTHERN  
 VAL SEC

MILE POST: MP 335.2

DATE: OCT. 2011  
 SCALE

SHEET OF

FOR -L- PROFILE SEE SHEET 14  
 FOR -Y4- PROFILE SEE SHEET 17

0302DEL\_P12  
 1/22/02

REVISIONS

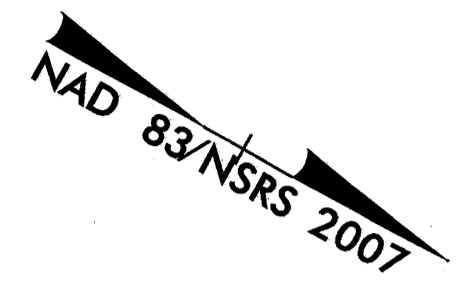
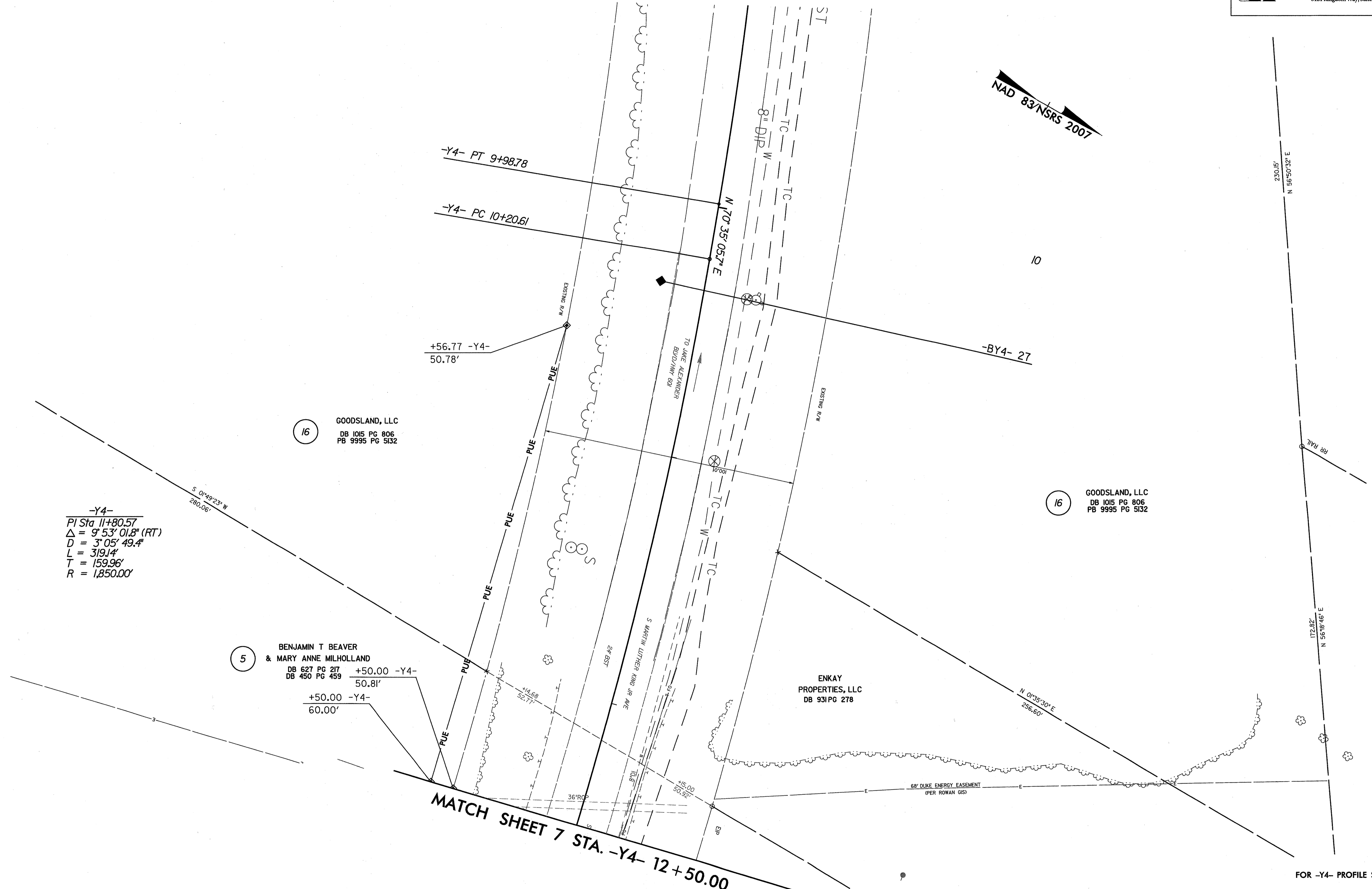

-Y4-  
 PI Sta 11+80.57  
 $\Delta = 9^{\circ} 53' 01.8''$  (RT)  
 $D = 3^{\circ} 05' 49.4''$   
 $L = 319.14'$   
 $T = 159.96'$   
 $R = 1,850.00'$

16  
 GOODSLAND, LLC  
 DB 1015 PG 806  
 PB 9995 PG 5132

16  
 GOODSLAND, LLC  
 DB 1015 PG 806  
 PB 9995 PG 5132

5  
 BENJAMIN T BEAVER  
 & MARY ANNE MILHOLLAND  
 DB 627 PG 217  
 DB 450 PG 459  
 +50.00 -Y4-  
 50.81'  
 +50.00 -Y4-  
 60.00'

ENKAY  
 PROPERTIES, LLC  
 DB 931 PG 278

MATCH SHEET 7 STA. -Y4- 12+50.00

FOR -Y4- PROFILE SEE SHEET 17

Florence & Hutcheson, Inc.  
 7/17/2012  
 R:\Rail\Roadway\Proj\KLU\KLU\Rail\psh07A.dgn

NO.	BY	DATE	REVISION

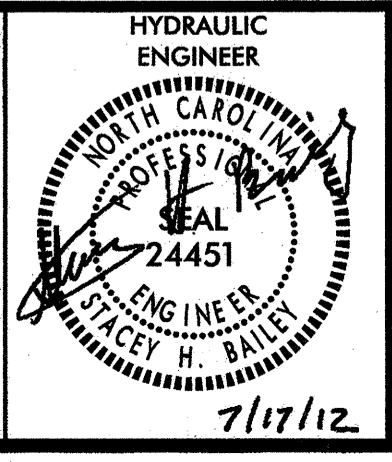
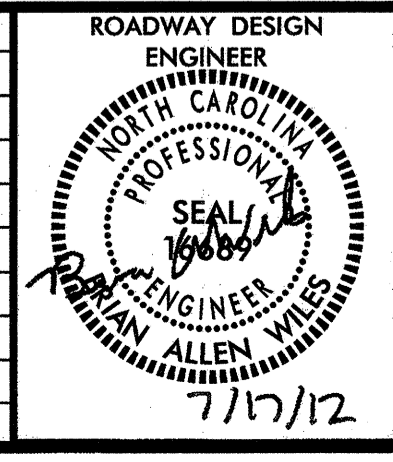

ROADWAY DESIGN ENGINEER  
 HYDRAULIC ENGINEER

NORTH CAROLINA DEPARTMENT OF TRANSPORTATION  
**RAIL DIVISION**

PREPARED BY: **ENGINEERING & SAFETY BRANCH**

MAIL: 1556 MAIL SERVICE CENTER RALEIGH, NC 27699-1556  
 DELIVERY: 360 CAPITAL BOULEVARD RALEIGH, NC 27603  
 PHONE: (919) 715-8803 FAX: (919) 715-8804

PROJECT U-3459 - KLUMAC ROAD		TITLE PLAN SHEET 7A	
LOCATION KLUMAC ROAD (SR 2541) IN SALISBURY, NC	RAILROAD NORTH CAROLINA RAILROAD/NORFOLK SOUTHERN	MILE POST MP 335.2	SHEET OF
DGN BY BAW	VAL SEC	DATE OCT. 2011	SCALE
DWN BY YTM			
CHK BY BAW			

NAD 83/NSRS 2007

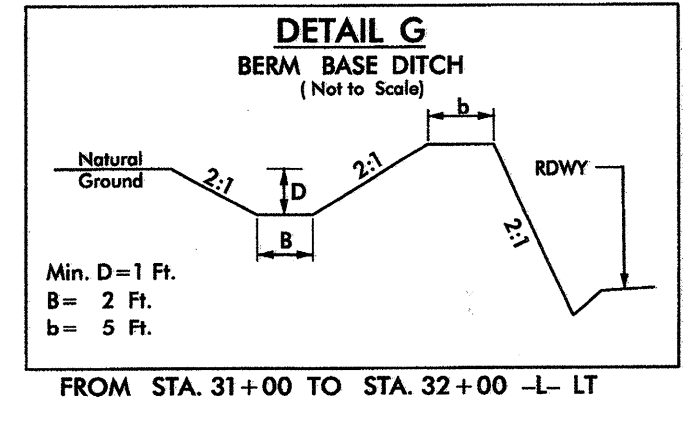
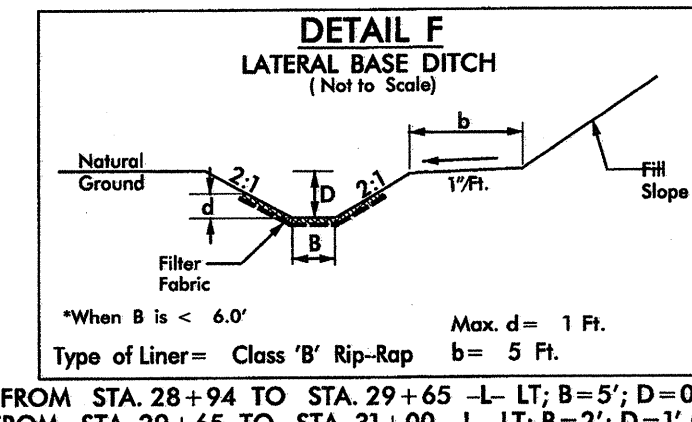
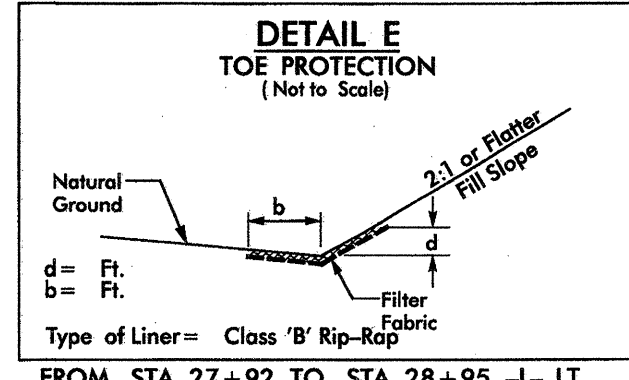

ENKAY PROPERTIES, LLC  
 DB 834 PG 330

-L-  
 PI Sta 26+97.31  
 Δ = 20° 07' 07.6" (RT)  
 D = 9' 32" 57.5"  
 L = 210.68'  
 T = 106.44'  
 R = 600.00'  
 SE = .04

MATCH SHEET 7 STA. -L- 27+00.00

MATCH SHEET 9 STA. -L- 32+00.00

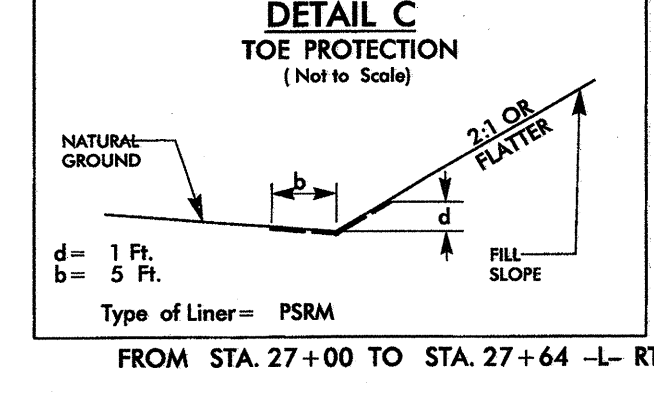
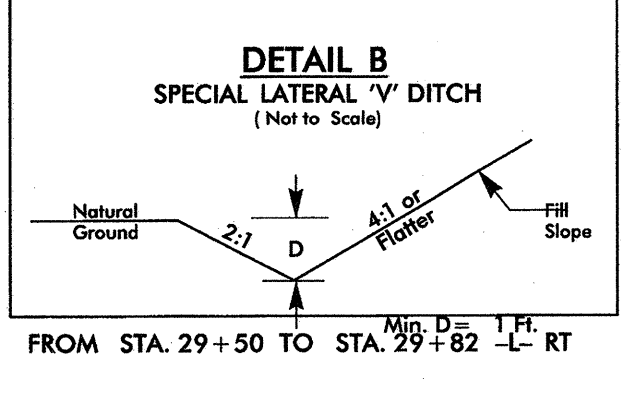
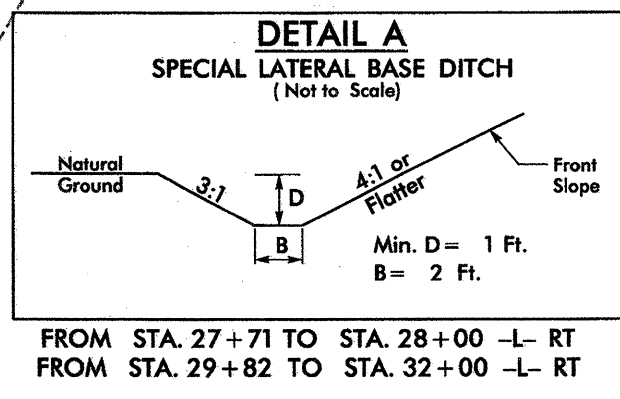
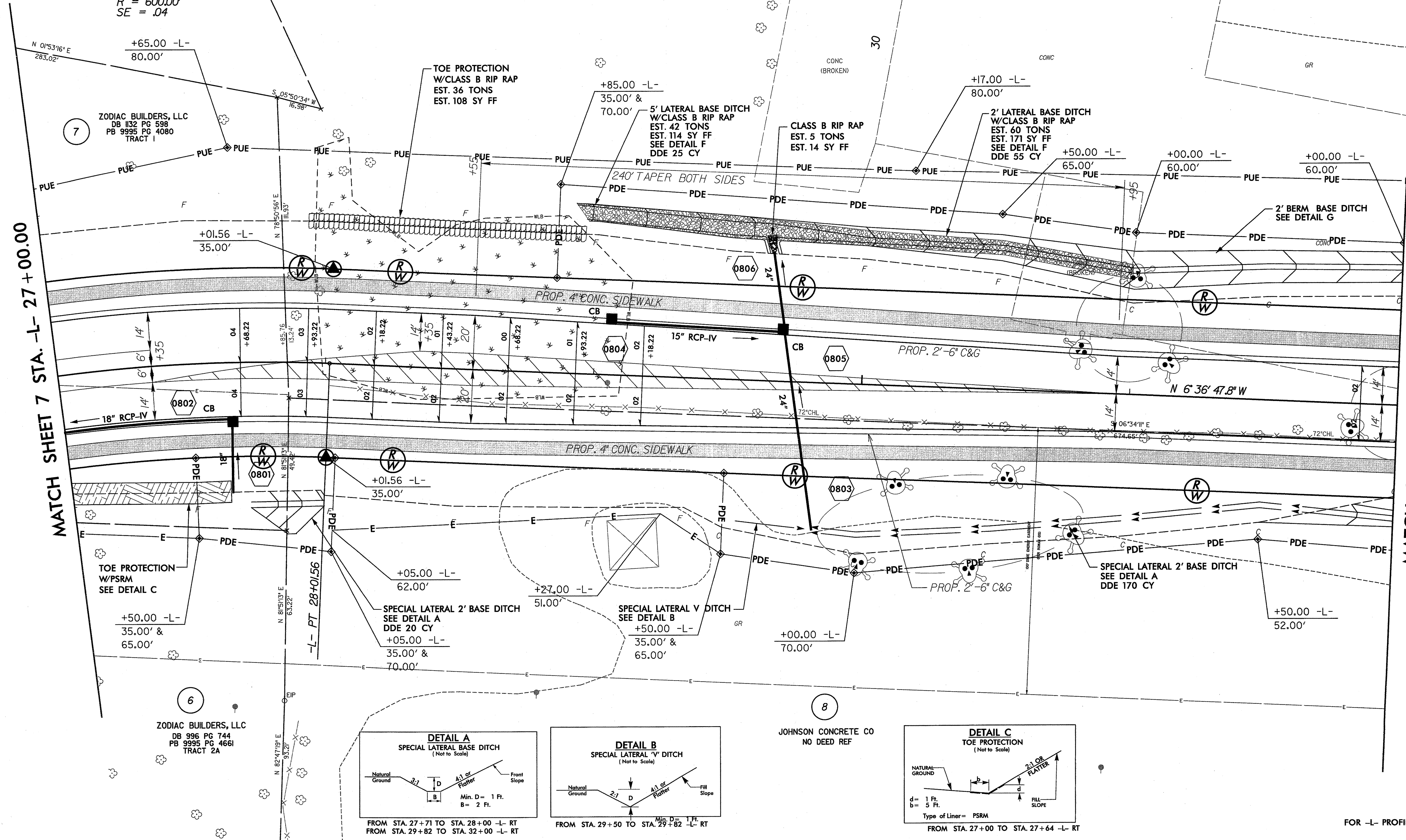

FOR -L- PROFILE SEE SHEET 15

Florence & Hutcheson, Inc.  
 7/17/2012  
 R:\Rail-Roadway\Proj\KLU\KLUAC\_Rail\_psh08.dgn

NO.	BY	DATE	REVISION

ROADWAY DESIGN ENGINEER

HYDRAULIC ENGINEER

NORTH CAROLINA DEPARTMENT OF TRANSPORTATION  
**RAIL DIVISION**  
 PREPARED BY: **ENGINEERING & SAFETY BRANCH**  
 MAIL: 1556 MAIL SERVICE CENTER, RALEIGH, NC 27699-1556  
 DELIVERY: 860 CAPITAL BOULEVARD, RALEIGH, NC 27603  
 PHONE: (919) 715-8803  
 FAX: (919) 715-8804

PROJECT: U-3459 - KLUMAC ROAD  
 TITLE: **PLAN SHEET 8**

LOCATION: KLUMAC ROAD (SR 2541) IN SALISBURY, NC

DGN BY: BAW	RAILROAD: NORTH CAROLINA RAILROAD/NORFOLK SOUTHERN	MILE POST: MP 335.2
DWN BY: YTM	VAL SEC:	
CHK BY: BAW	DATE: OCT. 2011	SCALE:

SHEET OF

0302DEL\_P12

1/22/02

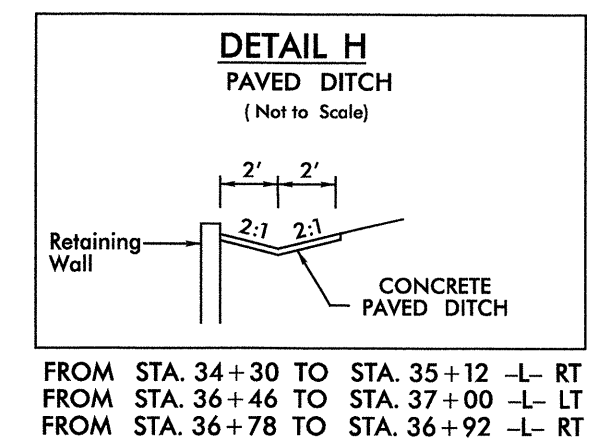
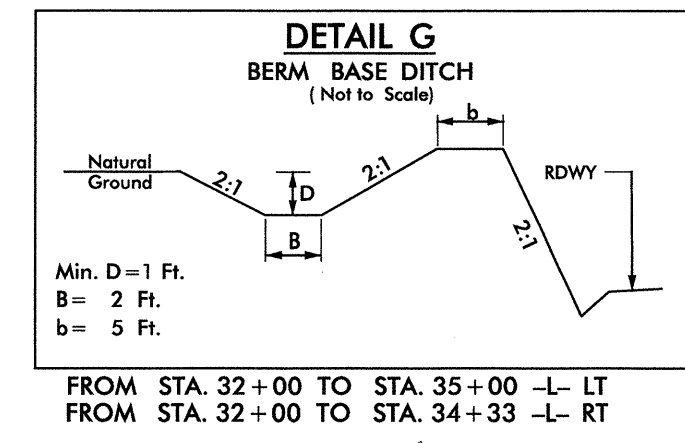

-L-  
 PI Sta 36+61.9  
 $\Delta = 20^\circ 44' 48.0''$  (LT)  
 $D = 3^\circ 49' 11.0''$   
 $L = 543.15'$   
 $T = 274.58'$   
 $R = 1,500.00'$   
 $SE = .03$

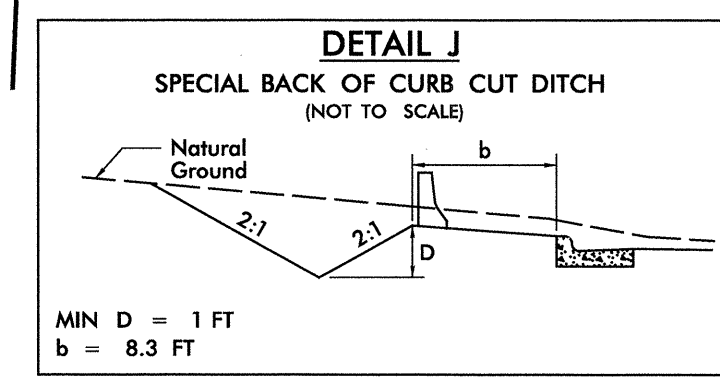
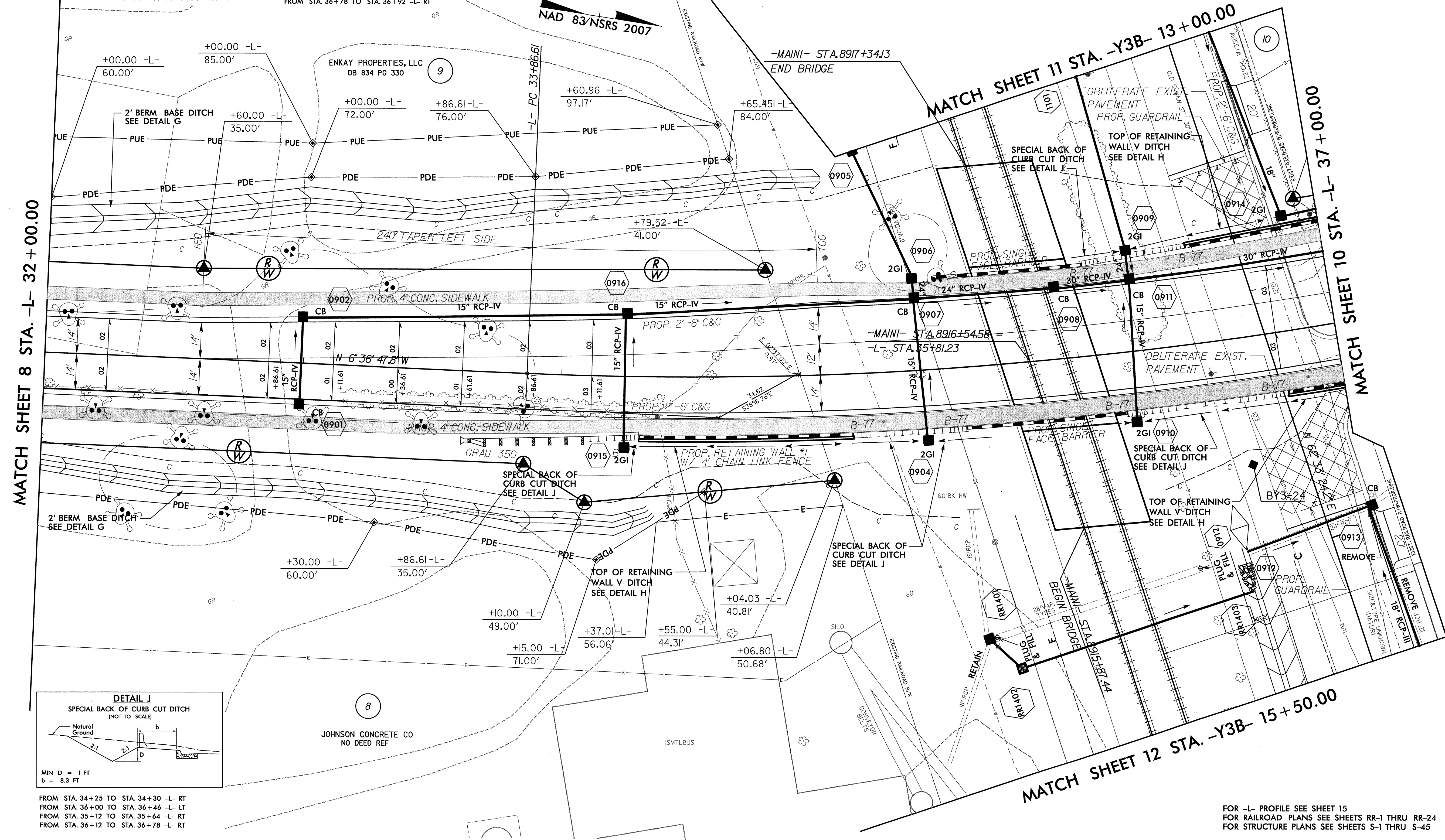

FROM STA. 34+25 TO STA. 34+30 -L- RT  
 FROM STA. 36+00 TO STA. 36+46 -L- LT  
 FROM STA. 35+12 TO STA. 35+64 -L- RT  
 FROM STA. 36+12 TO STA. 36+78 -L- RT

FOR -L- PROFILE SEE SHEET 15  
 FOR RAILROAD PLANS SEE SHEETS RR-1 THRU RR-24  
 FOR STRUCTURE PLANS SEE SHEETS S-1 THRU S-45

Florence & Hutcheson, Inc.  
 8/9/2012  
 R:\Rail-Roadway\Proj\KLU\KLUAC\_Rail.psh09.dgn

NO.	BY	DATE	REVISION

ROADWAY DESIGN ENGINEER  
  
 8/1/12

HYDRAULIC ENGINEER  
  
 8/1/12

NORTH CAROLINA DEPARTMENT OF TRANSPORTATION  
**RAIL DIVISION**  
 PREPARED BY:  
**ENGINEERING & SAFETY BRANCH**  
 MAIL: 1526 MAIL SERVICE CENTER, RALEIGH, NC 27699-1526  
 DELIVERY: 860 CAPITAL BUILDING, RALEIGH, NC 27603  
 PHONE: (919) 715-8803  
 FAX: (919) 715-8804

PROJECT TITLE	U-3459 - KLUMAC ROAD		
LOCATION	KLUMAC ROAD (SR 2541) IN SALISBURY, NC		
DGN BY	BAW	RAILROAD	NORTH CAROLINA RAILROAD/NORFOLK SOUTHERN
DWN BY	YTM	VAL SEC	
CHK BY	BAW	DATE	OCT. 2011
MILE POST	MP 335.2	SHEET	OF
SCALE			

**MATCH SHEET 11A STA. -Y2- 11+20.00**

**BEGIN CONSTRUCTION**  
-Y2- POT STA. 11+45.00

**END CONSTRUCTION**  
-Y2A- POT 11+8.92 =  
-Y2B- POT 10+00.00  
-Y2A- 11+52  
**END 1 1/2" OVERLAY OF \$9.5B,  
MILL AT TIE-IN.**

**END CONSTRUCTION**  
-Y2B- 10+72  
**END 1 1/2" OVERLAY OF \$  
MILL AT TIE-IN.**

**END CONSTRUCTION**  
-Y2B- POT 10+00.00 =  
-Y2A- POT 10+00.00

**END CONSTRUCTION**  
-Y2- POT STA. 14+65.00

MATCH SHEET 9 STA. -L- 37+00.00

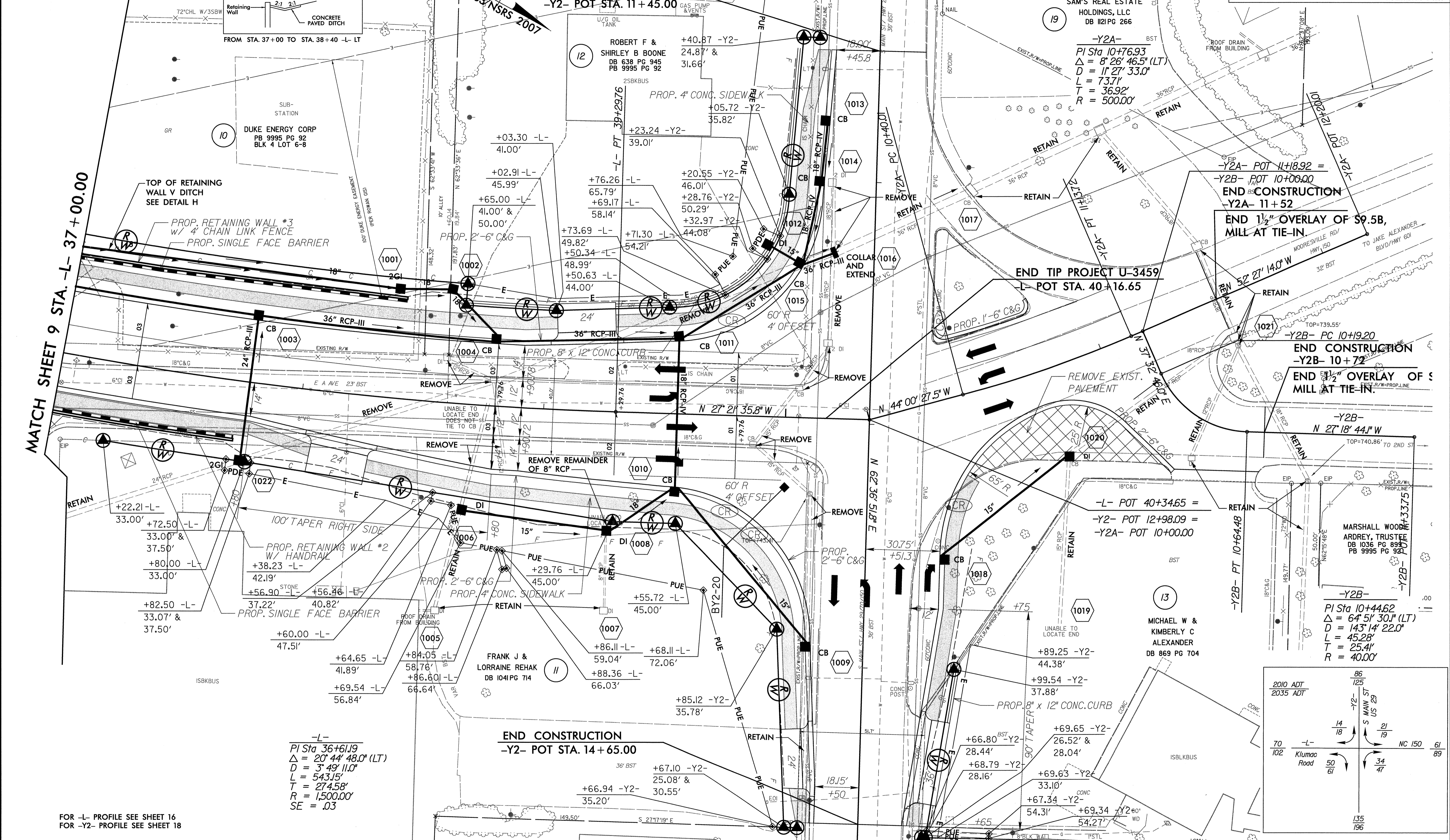
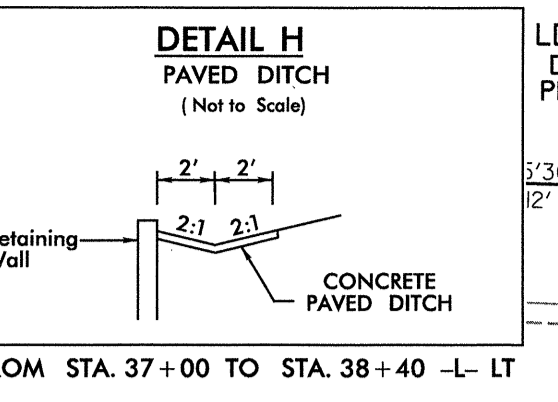

0302DEL\_P12

1/22/02

REVISIONS

FOR -L- PROFILE SEE SHEET 16  
FOR -Y2- PROFILE SEE SHEET 18

Florence & Hutcheson, Inc.  
8/8/2012  
R:\Rail-Roadway\Proj\K\Klumac\_Rail\_Psh10.dgn

NO.	BY	DATE	REVISION

ROADWAY DESIGN ENGINEER  
**PROFESSIONAL SEAL**  
NORTH CAROLINA  
ENGINEER  
BRIAN ALLEN WILES  
10689  
8/11/12

HYDRAULIC ENGINEER  
**PROFESSIONAL SEAL**  
NORTH CAROLINA  
ENGINEER  
JAMES BAILEY  
24451  
8/11/12

**RAIL DIVISION**  
NORTH CAROLINA DEPARTMENT OF TRANSPORTATION  
ENGINEERING & SAFETY BRANCH  
PREPARED BY: [Signature]  
MAIL: 1056 MAIL SERVICE CENTER RALEIGH, NC 27699-1556  
DELIVERY: 860 CAPITAL BOULEVARD RALEIGH, NC 27603  
PHONE: (919) 715-9803 FAX: (919) 715-9804

PROJECT U-3459 - KLUMAC ROAD  
TITLE PLAN SHEET 10  
LOCATION KLUMAC ROAD (SR 2541) IN SALISBURY, NC  
DGN BY BAW RAILROAD NORTH CAROLINA RAILROAD/NORFOLK SOUTHERN MILE POST MP 335.2  
DWN BY YTM VAL SEC  
CHK BY BAW DATE OCT. 2011 SCALE  
SHEET OF



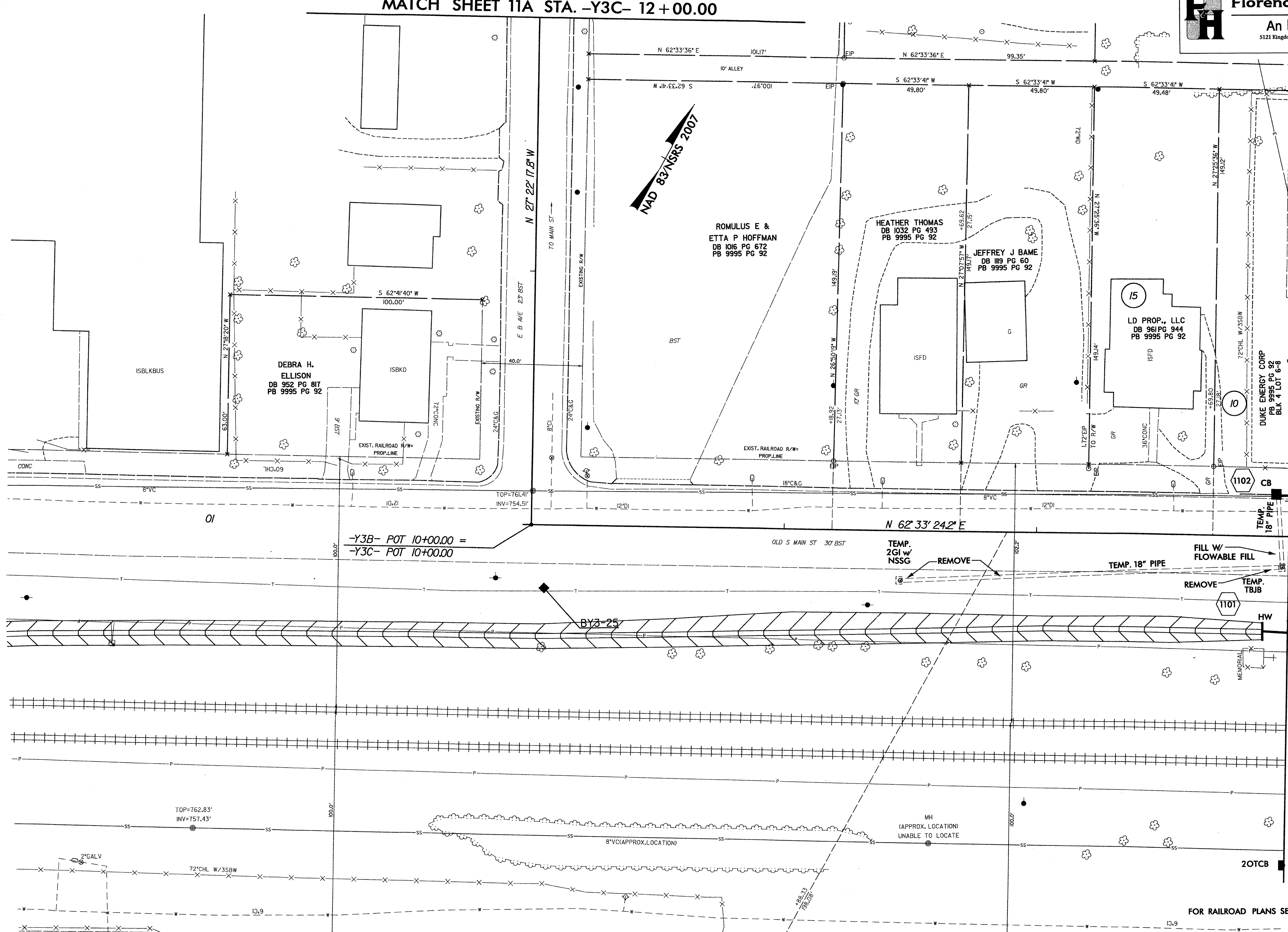

MATCH SHEET 9 STA. -Y3B- 13 + 00.00

FOR RAILROAD PLANS SEE SHEETS RR-1 THRU RR-24

1/22/02

Florence & Hutcheson, Inc.  
8/20/2012  
R:\Rail-Roadway\Proj\K\UMAC.Rail\_Psh11.dgn

NO.	BY	DATE	REVISION

ROADWAY DESIGN ENGINEER  
  
 8/20/12

HYDRAULIC ENGINEER  
  
 8/20/12

PREPARED BY:  
  
**ENGINEERING & SAFETY BRANCH**  
 MAIL: 1556 MAIL SERVICE CENTER, RALEIGH, NC 27699-4556  
 DELIVERY: 860 CAPITAL BOULEVARD, RALEIGH, NC 27603  
 PHONE: (919) 715-8803  
 FAX: (919) 715-8804

PROJECT U-3459 - KLUMAC ROAD		TITLE PLAN SHEET 11	
LOCATION KLUMAC ROAD (SR 2541) IN SALISBURY, NC			
DGN BY BAW	RAILROAD NORTH CAROLINA RAILROAD/NORFOLK SOUTHERN	MILE POST	MP 335.2
DWN BY YTM	VAL SEC		
CHK BY BAW	DATE OCT. 2011	SCALE	SHEET OF

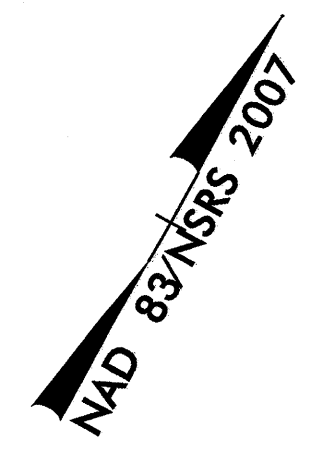

0302DEL\_P12

1/22/02

REVISIONS

BY2-21

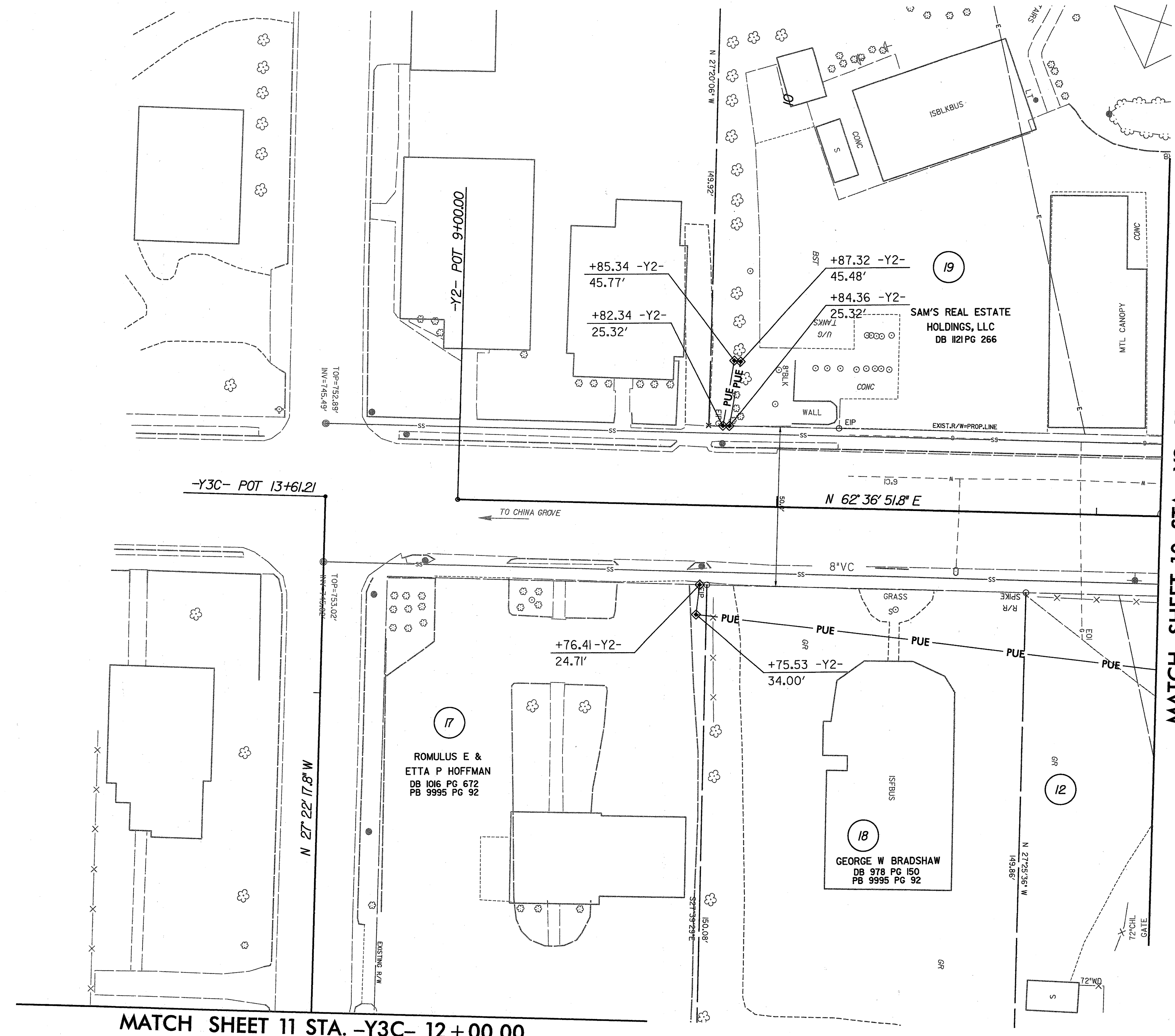

MATCH SHEET 10 STA. -Y2- 11 + 20.00

MATCH SHEET 11 STA. -Y3C- 12 + 00.00

Florence & Hutcheson, Inc.  
 7/17/2012  
 R:\Rail-Roadway\Proj\KLU\MAC\_Rail\psh11A.dgn

NO.	BY	DATE	REVISION

ROADWAY DESIGN ENGINEER  
  
 12/31/12

HYDRAULIC ENGINEER  
  
 7/17/12

NORTH CAROLINA DEPARTMENT OF TRANSPORTATION  
**RAIL DIVISION**  
 PREPARED BY: **ENGINEERING & SAFETY BRANCH**  
 MAIL: 1536 MAIL SERVICE CENTER, RALEIGH, NC 27699-1556  
 DELIVERY: 380 CAPITAL BOULEVARD, RALEIGH, NC 27603  
 PHONE: (919) 715-8803  
 FAX: (919) 715-8804

PROJECT U-3459 - KLUMAC ROAD		TITLE PLAN SHEET 11A	
LOCATION KLUMAC ROAD (SR 2541) IN SALISBURY, NC			
DGN BY BAW	RAILROAD NORTH CAROLINA RAILROAD/NORFOLK SOUTHERN	MILE POST MP 335.2	
DWN BY YTM	VAL SEC		
CHK BY BAW	DATE OCT. 2011	SCALE	SHEET OF



0302DEL\_P12

1/22/02

REVISIONS

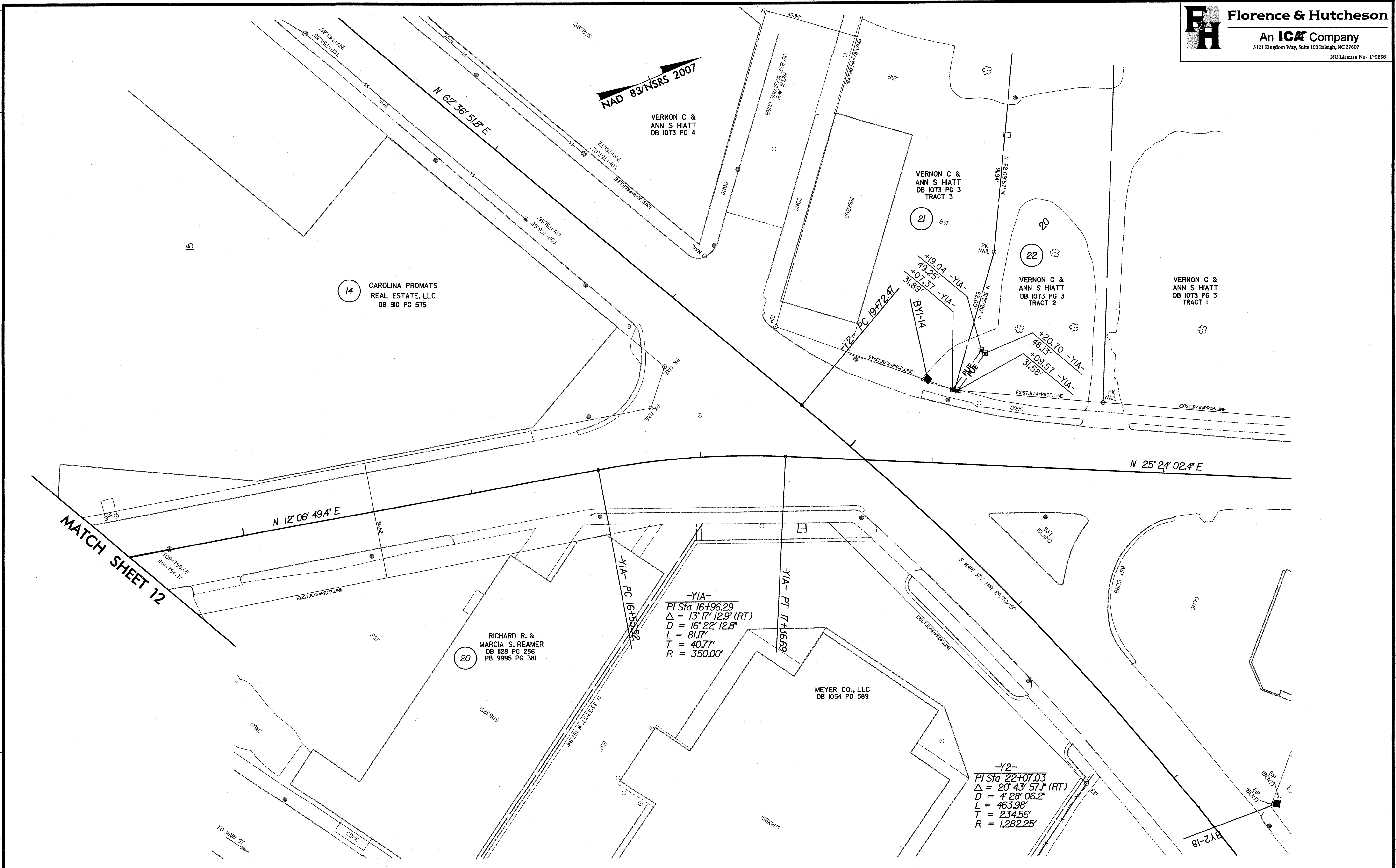

NO.	BY	DATE	REVISION

ROADWAY DESIGN ENGINEER

HYDRAULIC ENGINEER

7/17/12

NORTH CAROLINA DEPARTMENT OF TRANSPORTATION

# RAIL DIVISION

PREPARED BY: **ENGINEERING & SAFETY BRANCH**

MAIL: 1556 MAIL SERVICE CENTER RALEIGH, NC 27699-1556  
 DELIVERY: 800 CAPITAL BOULEVARD RALEIGH, NC 27603  
 PHONE: (919) 715-8803 FAX: (919) 715-8804

PROJECT U-3459 - KLUMAC ROAD

TITLE **PLAN SHEET 12A**

LOCATION KLUMAC ROAD (SR 2541) IN SALISBURY, NC

DGN BY	BAW	RAILROAD	NORTH CAROLINA RAILROAD/NORFOLK SOUTHERN	MILE POST	MP 335.2
DWN BY	YTM	VAL SEC			
CHK BY	BAW	DATE	OCT. 2011	SCALE	

SHEET  OF

Florence & Hutcheson, Inc.  
 7/17/2012  
 RA:\Rail\Roadway\Proj\Klumac\_Rail\psh12a.dgn

0302DEL\_P12

1/22/02

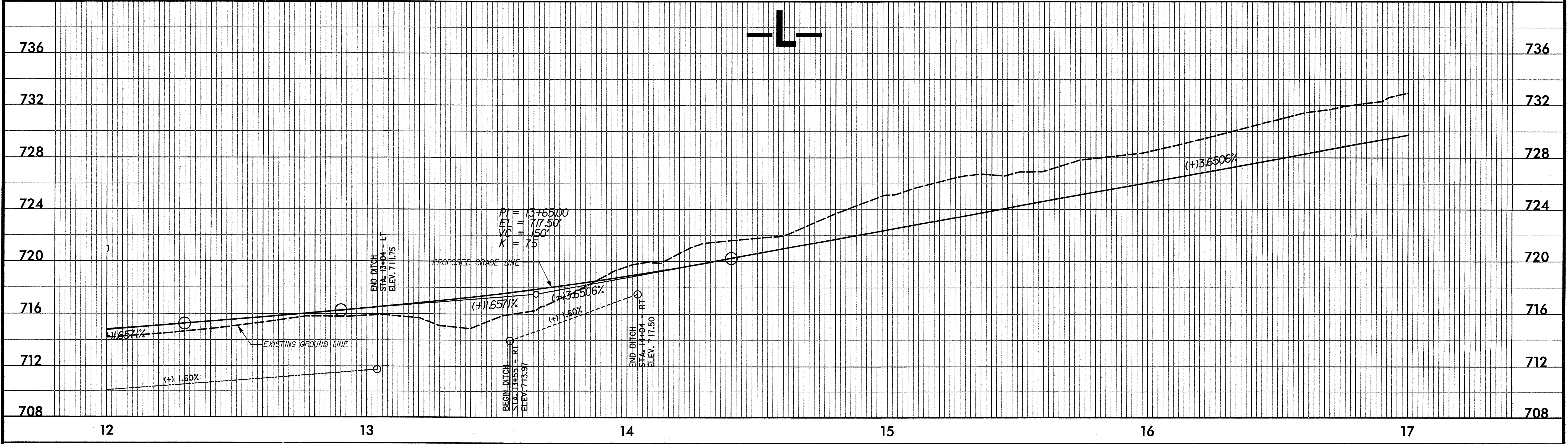
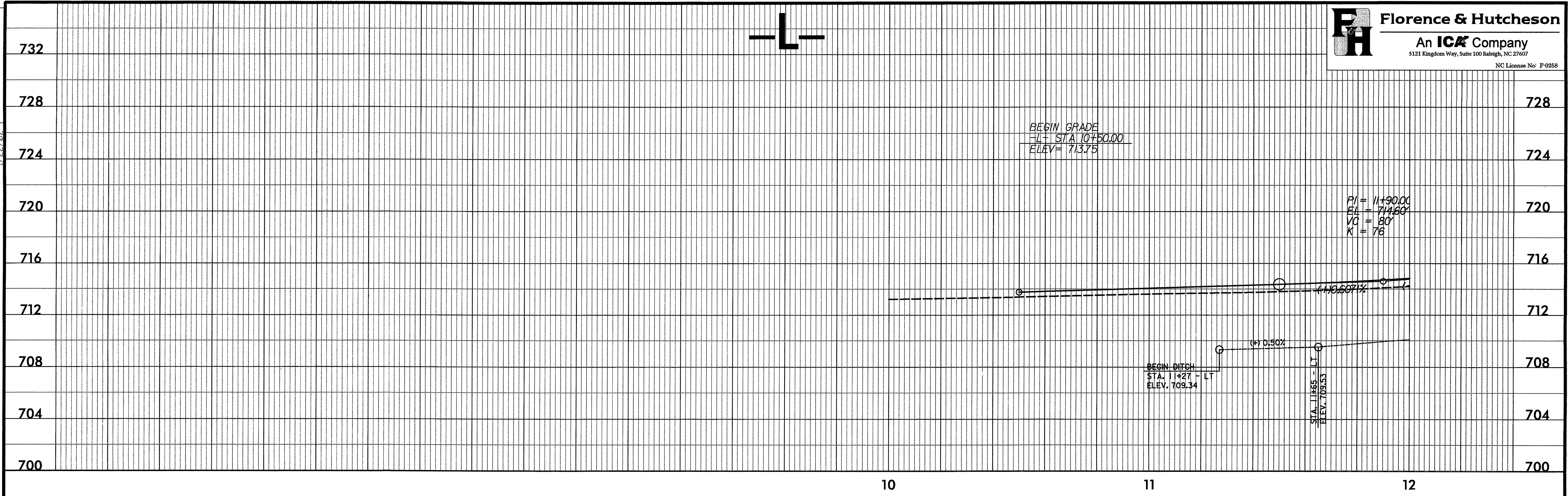

Florence & Hutcheson, Inc.  
 7/17/2012  
 R:\Rail-Roadway\Proj\KLU\KLU\KLU\Rail.dwg

NO.	BY	DATE	REVISION

ROADWAY DESIGN ENGINEER

HYDRAULIC ENGINEER

NORTH CAROLINA DEPARTMENT OF TRANSPORTATION  
**RAIL DIVISION**

PROJECT	U-3459 - KLUMAC ROAD		
TITLE	PLAN SHEET 13 -L- PROFILE		
LOCATION	KLUMAC ROAD (SR 2541) IN SALISBURY, NC		
DGN BY	BAW	RAILROAD	NORTH CAROLINA RAILROAD/NORFOLK SOUTHERN
DWN BY	YTM	VAL SEC	MILE POST MP 335.2
CHK BY	BAW	DATE	OCT. 2011
SCALE			
			SHEET 13 OF

**PIPE HYDRAULIC DATA**  
 18" RCP - STA. 20+20 -L-

DRAINAGE AREA	=	2.3	AC
DESIGN FREQUENCY	=	25	YRS
DESIGN DISCHARGE	=	7	CFS
DESIGN HW ELEVATION	=	736.5	FT
100 YEAR DISCHARGE	=	8	CFS
100 YEAR HW ELEVATION	=	736.7	FT
OVERTOPPING FREQUENCY	=	500+	YRS
OVERTOPPING DISCHARGE	=	25	CFS
OVERTOPPING ELEVATION	=	742J	FT

P/ = 21+95.00  
 EL = 747.80'  
 VC = 120'  
 K = 50

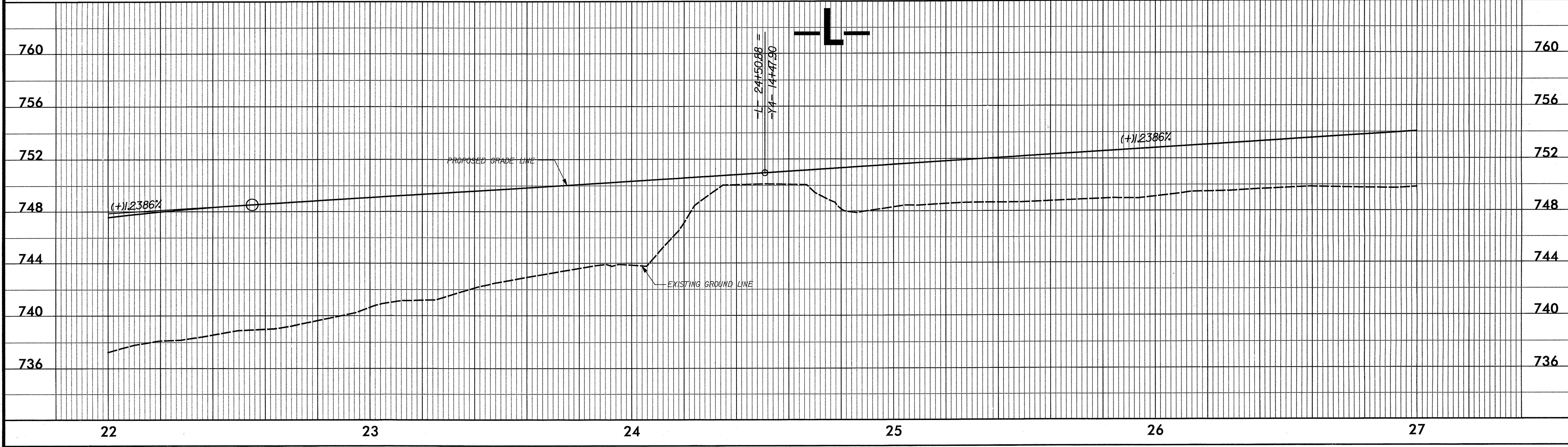
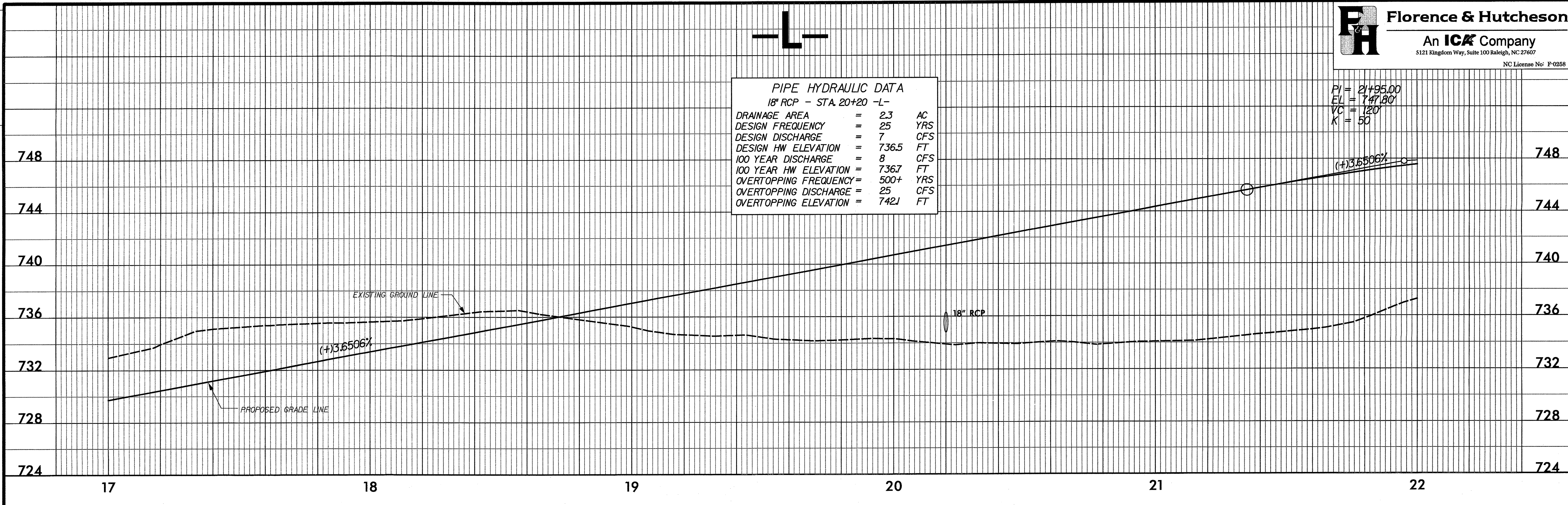

0302DEL\_P12

1/22/02

Florence & Hutcheson, Inc.  
 7/17/2012  
 R:\Rail Roadway\Proj\KLU\KLU\Rail\_P114.dgn

NO.	BY	DATE	REVISION

ROADWAY DESIGN ENGINEER 	HYDRAULIC ENGINEER 
-----------------------------	------------------------

NORTH CAROLINA DEPARTMENT OF TRANSPORTATION  
**RAIL DIVISION**

PROJECT U-3459 - KLUMAC ROAD		TITLE PLAN SHEET 14 -L- PROFILE	
LOCATION KLUMAC ROAD (SR 2541) IN SALISBURY, NC	RAILROAD NORTH CAROLINA RAILROAD/NORFOLK SOUTHERN	MILE POST MP 335.2	SHEET 14 OF
DGN BY BAW	VAL SEC		
DWN BY YTM	DATE OCT. 2011	SCALE	

0302DEL\_P12

1/22/02

PIPE HYDRAULIC DATA	
24" RCP - STA. 29+73 -L-	
DRAINAGE AREA	= 4.0 AC
DESIGN FREQUENCY	= 25 YRS
DESIGN DISCHARGE	= 12 CFS
DESIGN HW ELEVATION	= 752.7 FT
100 YEAR DISCHARGE	= 14 CFS
100 YEAR HW ELEVATION	= 752.8 FT
OVERTOPPING FREQUENCY	= 500+ YRS
OVERTOPPING DISCHARGE	= 36 CFS
OVERTOPPING ELEVATION	= 757.6 FT

PI = 30+75.00  
 EL = 758.70'  
 VC = 280'  
 K = 52

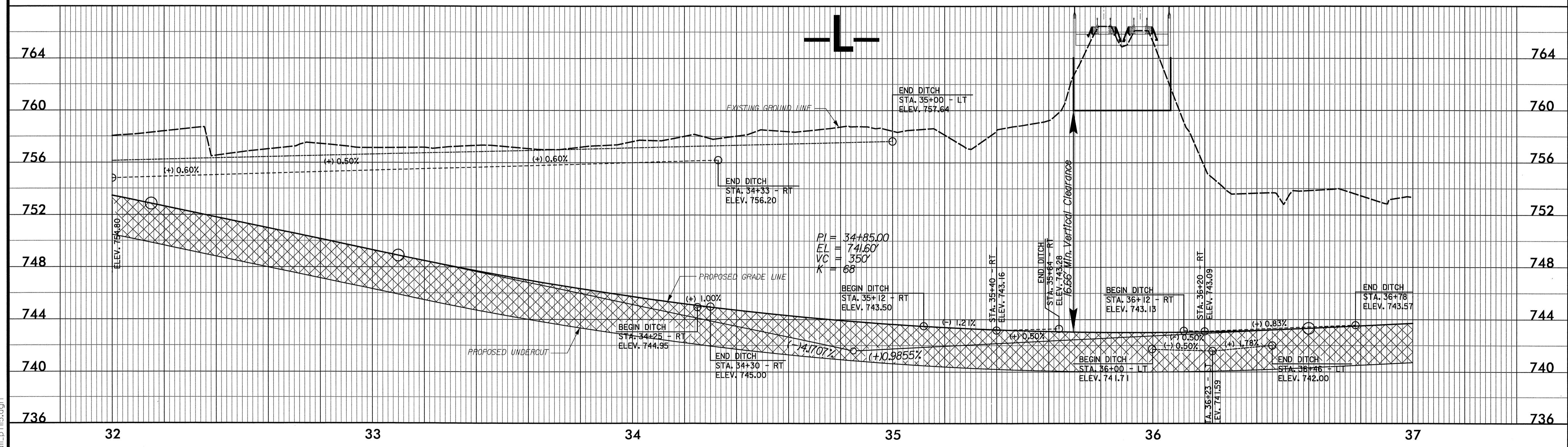
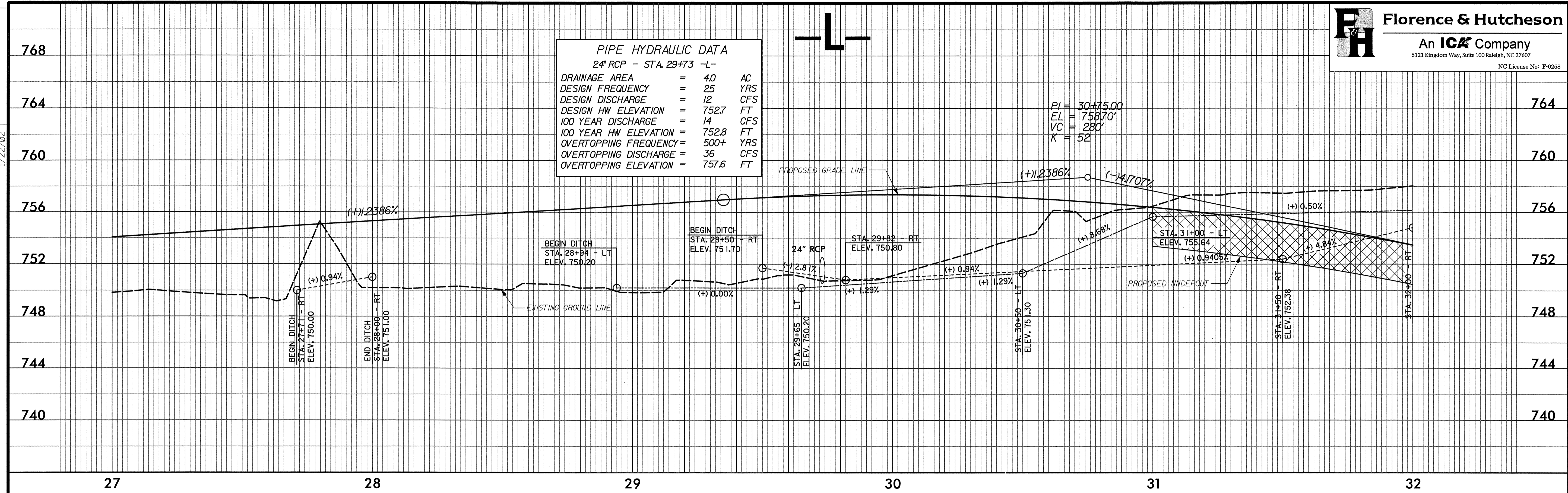

PI = 34+85.00  
 EL = 741.60'  
 VC = 350'  
 K = 68

<p>Florence &amp; Hutcheson, Inc.                  8/31/2012                  R:\Rail-Roadway\Proj\Klumac_Rail_P12.dgn</p>				<p>ROADWAY DESIGN ENGINEER                  [Signature]</p>	<p>HYDRAULIC ENGINEER                  [Signature]</p>	<p>NORTH CAROLINA DEPARTMENT OF TRANSPORTATION  <b>RAIL DIVISION</b></p>	<p>PROJECT U-3459 - KLUMAC ROAD                  TITLE                  PLAN SHEET 15                  -L- PROFILE</p>
<p>NO. BY DATE REVISION</p>				<p>SEAL                  16689                  ALLEN WILES                  8/31/12</p>	<p>SEAL                  24451                  JACEY H. RAILLY                  8/31/12</p>	<p>LOCATION KLUMAC ROAD (SR 2541) IN SALISBURY, NC                  DGN BY BAW RAILROAD NORTH CAROLINA RAILROAD/NORFOLK SOUTHERN MILE POST MP 335.2                  DWN BY YTM VAL SEC                  CHK BY BAW DATE OCT. 2011 SCALE</p>	<p>SHEET 15 OF</p>

DGN 0302DEL\_P12

1/22/02

-L-

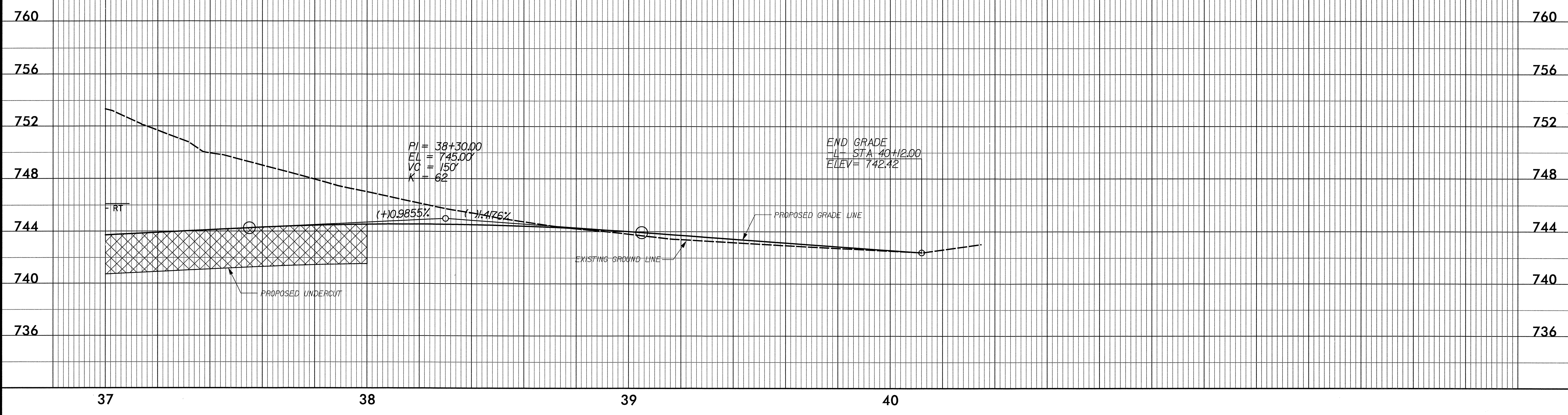

Florence & Hutcheson, Inc.  
 8/31/2012  
 R:\Rail-Roadway\Proj\KLUMAC\_Rail\_P12.dgn

NO.	BY	DATE	REVISION

ROADWAY DESIGN ENGINEER

HYDRAULIC ENGINEER

NORTH CAROLINA DEPARTMENT OF TRANSPORTATION  
  
**RAIL DIVISION**

PROJECT	U-3459 - KLUMAC ROAD		
TITLE	<b>PLAN SHEET 16 -L- PROFILE</b>		
LOCATION	KLUMAC ROAD (SR 2541) IN SALISBURY, NC		
DGN BY	BAW	RAILROAD	NORTH CAROLINA RAILROAD/NORFOLK SOUTHERN
DWN BY	YTM	VAL SEC	MILE POST MP 335.2
CHK BY	BAW	DATE	OCT. 2011
		SCALE	
			<b>SHEET 16 OF</b>



**-Y1-**

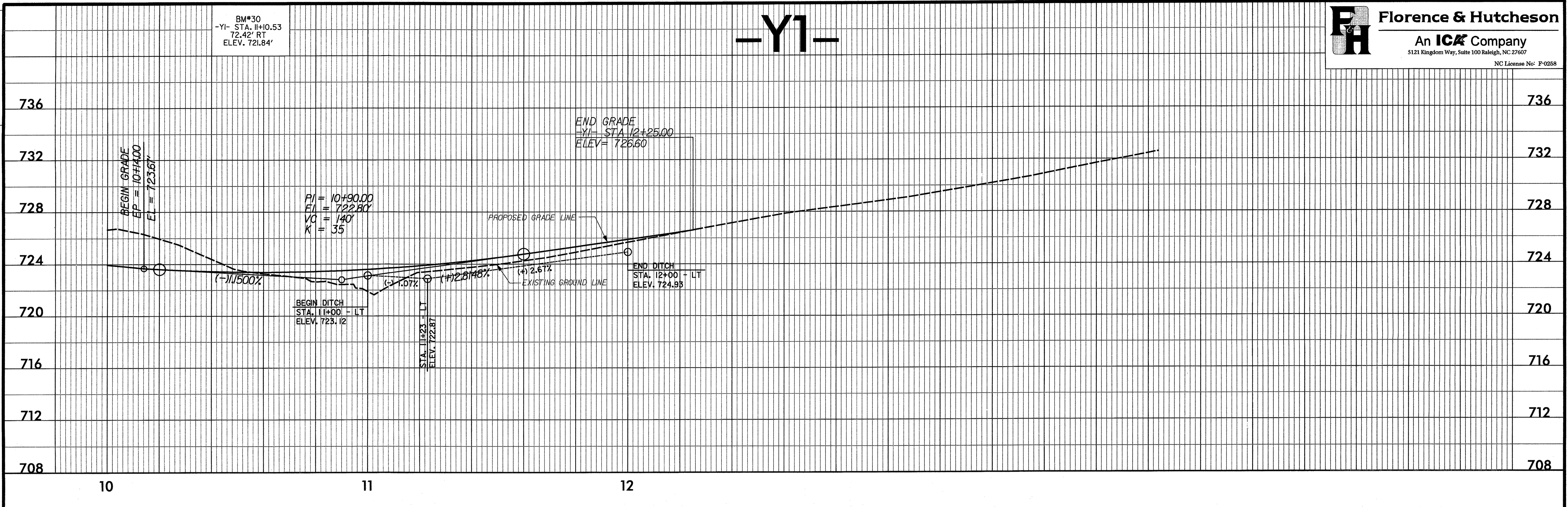

**-Y4-**

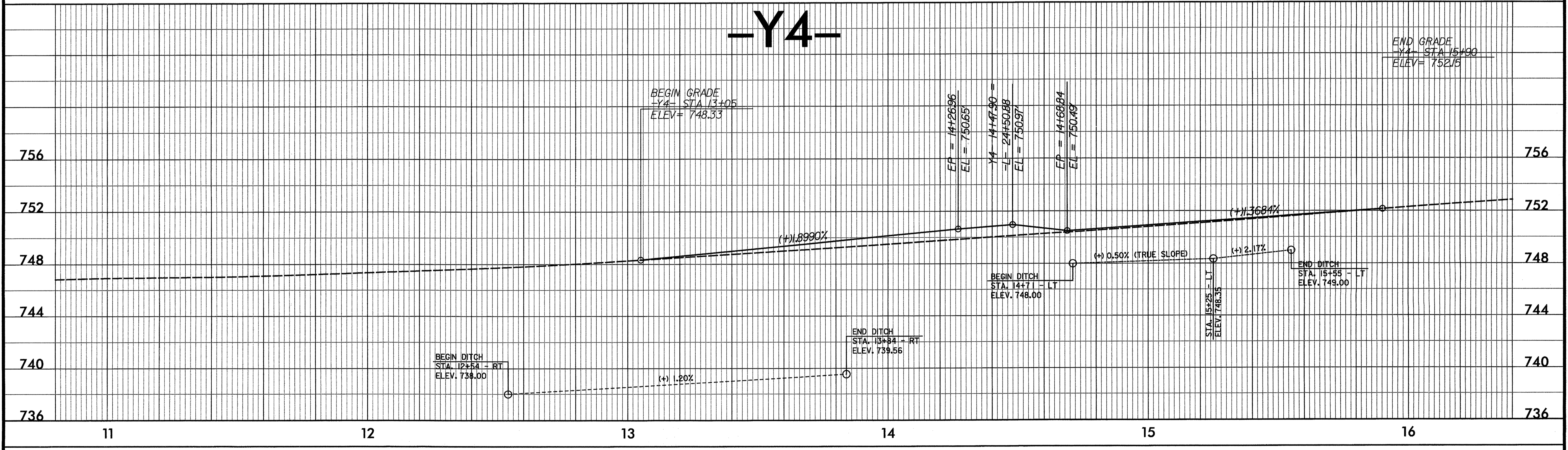

Florence & Hutcheson, Inc.  
 7/17/2012  
 R:\Rail-Roadway\Proj\KUMAC\_Road\p.dwg

NO.	BY	DATE	REVISION

ROADWAY DESIGN ENGINEER

HYDRAULIC ENGINEER

NORTH CAROLINA DEPARTMENT OF TRANSPORTATION

**RAIL DIVISION**

PROJECT U-3459 - KLUMAC ROAD

TITLE PLAN SHEET 17  
-Y1- AND -Y4- PROFILE

LOCATION KLUMAC ROAD (SR 2541) IN SALISBURY, NC

DGN BY	BAW	RAILROAD	NORTH CAROLINA RAILROAD/NORFOLK SOUTHERN	MILE POST	MP 335.2
DWN BY	YTM	VAL SEC			
CHK BY	BAW	DATE	OCT. 2011	SCALE	

SHEET 17 OF

**-Y2-**

0302DEL\_P12

1/22/02

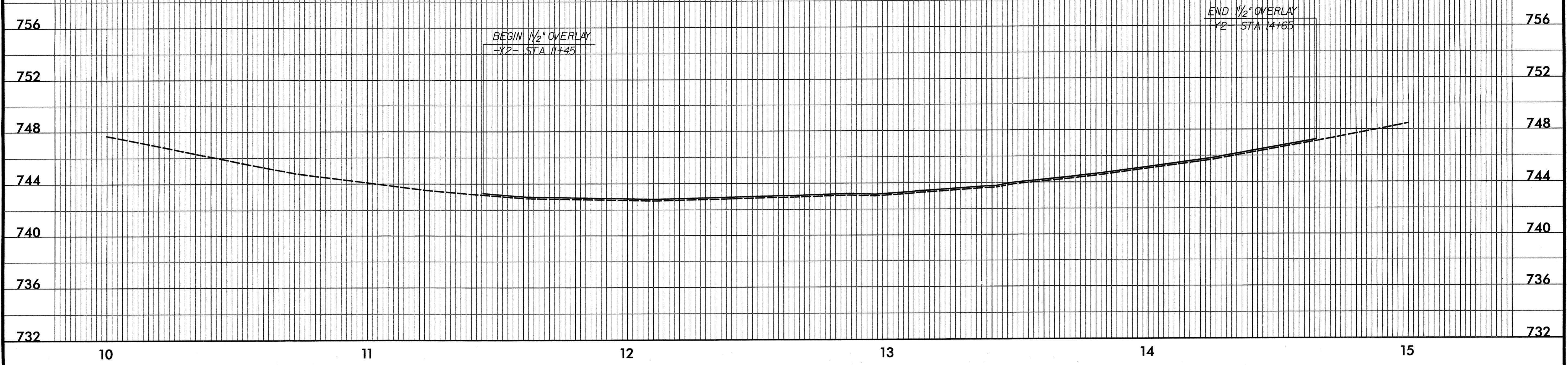

**-Y2-**

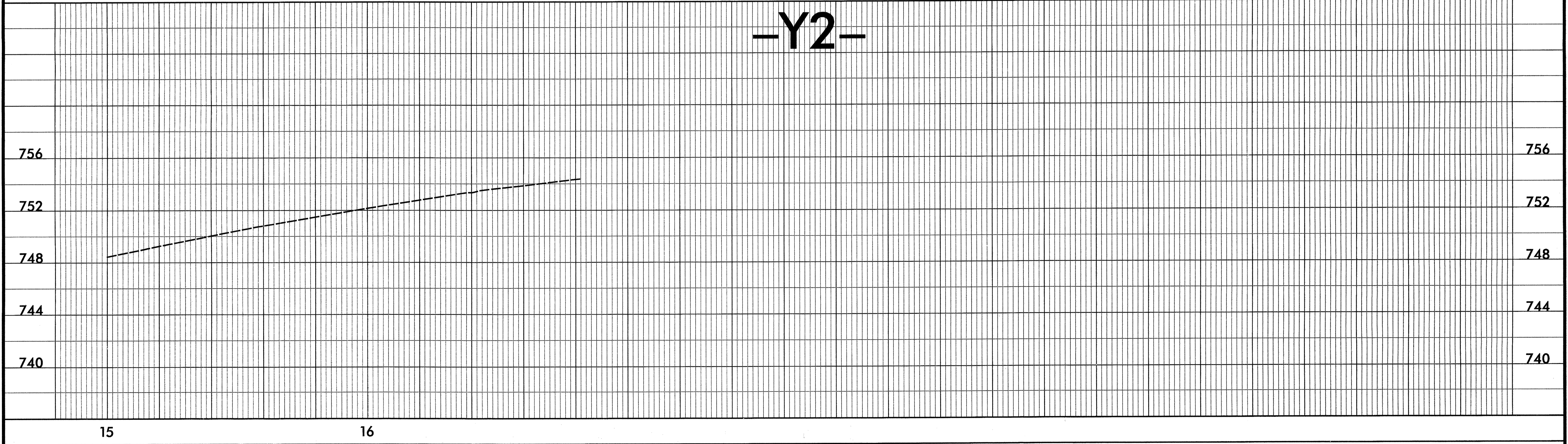

Florence & Hutcheson, Inc.  
 7/17/2012  
 BA\Rail\Roadway\Proj\K\KUMAC\_Rail\_P.f118.dgn

NO.	BY	DATE	REVISION

ROADWAY DESIGN ENGINEER 	HYDRAULIC ENGINEER 
--------------------------------	---------------------------

NORTH CAROLINA DEPARTMENT OF TRANSPORTATION  
**RAIL DIVISION**

PROJECT U-3459 - KLUMAC ROAD		<b>PLAN SHEET 18</b> <b>-Y2- PROFILE</b>	
TITLE			
LOCATION KLUMAC ROAD (SR 2541) IN SALISBURY, NC		MILE POST MP 335.2	
DGN BY BAW	RAILROAD NORTH CAROLINA RAILROAD/NORFOLK SOUTHERN	SCALE	
DWN BY YTM	VAL SEC	SHEET 18 OF	
CHK BY BAW	DATE OCT. 2011		