

STATE OF NORTH CAROLINA
DIVISION OF HIGHWAYS

CABARRUS COUNTY

LOCATION: BRIDGE NO. 163 OVER REEDY CREEK ON
SR 1138 (HICKORY RIDGE RD.)

TYPE OF WORK: GRADING, PAVING, DRAINAGE AND STRUCTURE

STATE	STATE PROJECT REFERENCE NO.	SHEET NO.	TOTAL SHEETS
N.C.	B-4719	1	
STATE PROJ. NO.	F.A. PROJ. NO.	DESCRIPTION	
38493.1.1	BRZ-1138 (15)	PE	
38493.2.1	BRZ-1138 (15)	RW & UTIL	
38493.3.1	BRZ-1138 (15)	CONST	

TIP PROJECT: B-4719

CONTRACT: C203018

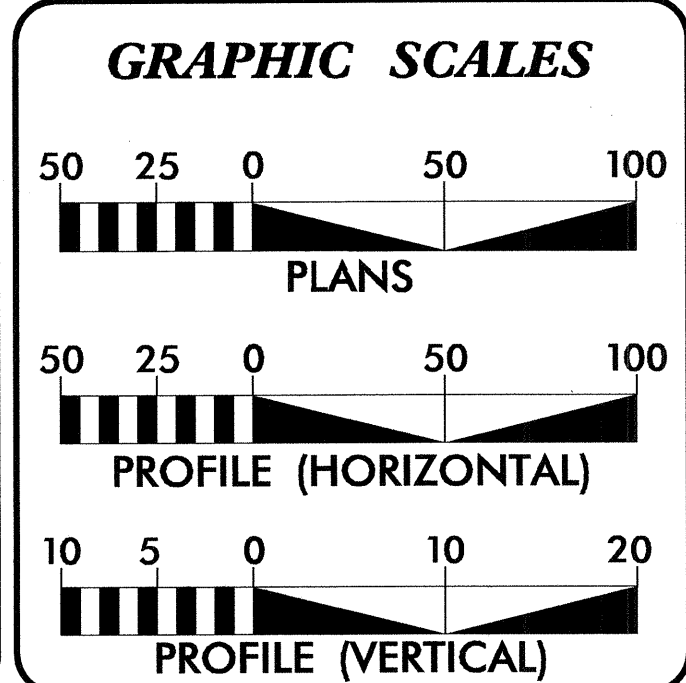
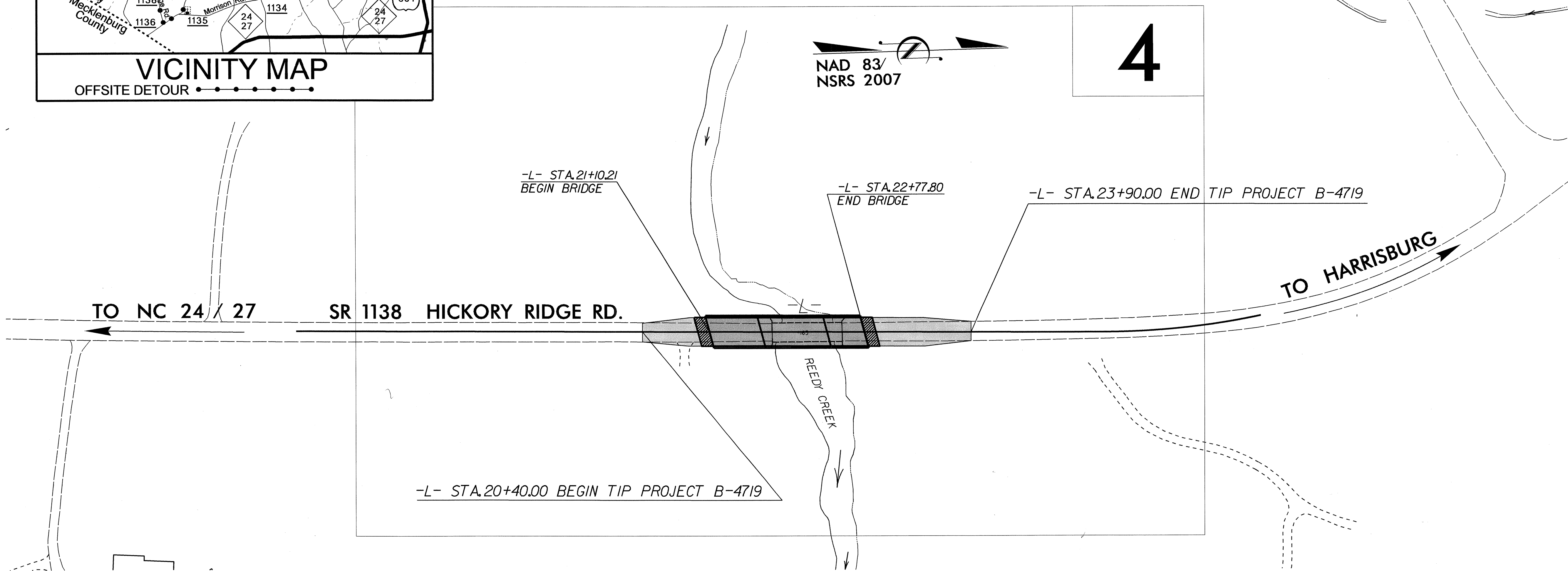
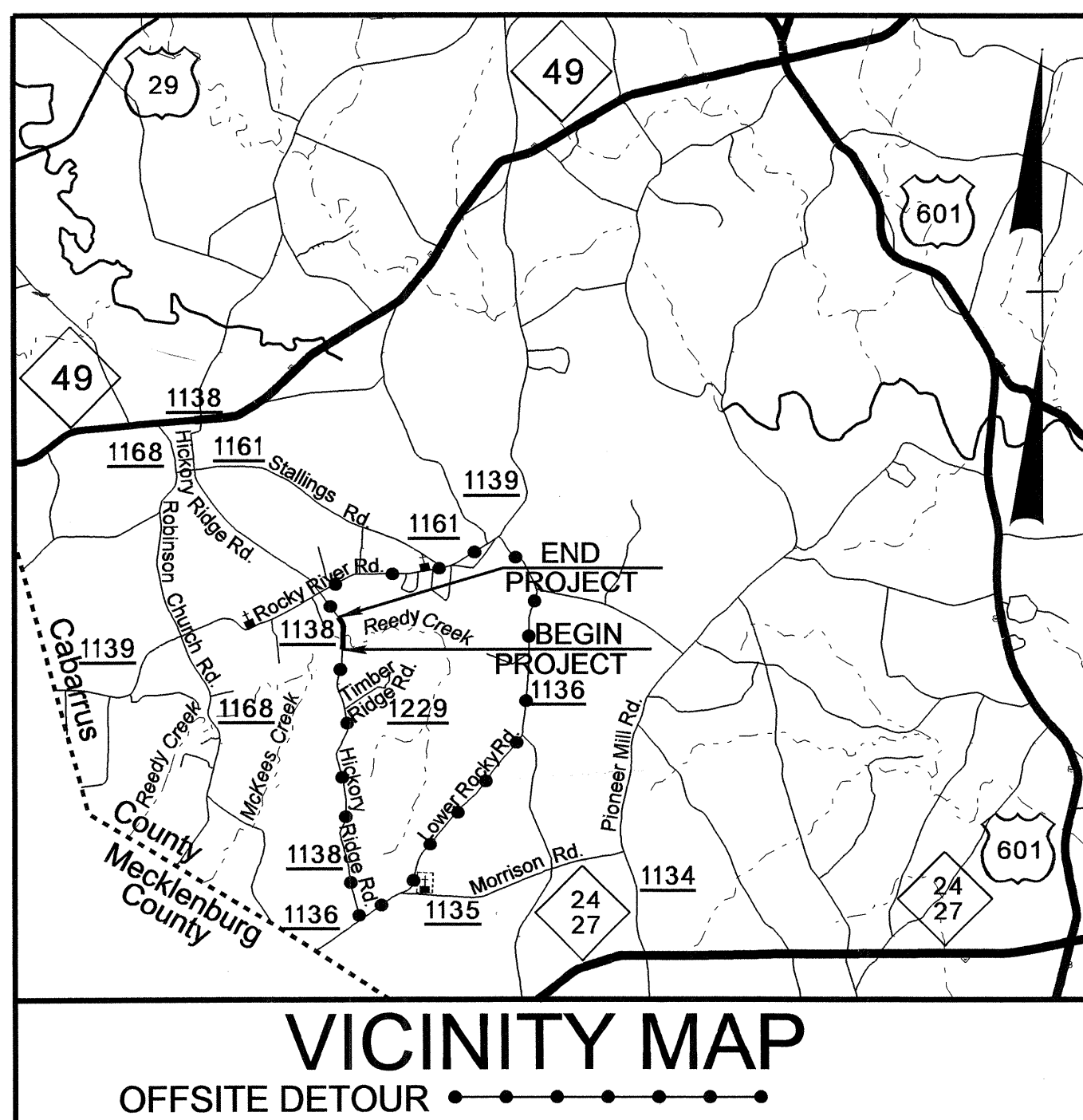

DESIGN DATA

ADT 2012 =	2525
ADT 2035 =	6700
DHV =	11 %
D =	55 %
*T =	6 %
V =	50 MPH
(RURAL LOCAL)	
SUB-REGIONAL TIER	
* TTST 5 % + DUAL 1 %	

PROJECT LENGTH

LENGTH OF ROADWAY TIP PROJECT B-4719 =	0.034 MI
LENGTH OF STRUCTURE TIP PROJECT B-4719 =	0.032 MI
TOTAL LENGTH OF TIP PROJECT B-4719 =	0.066 MI

Prepared in the Office of:

DIVISION OF HIGHWAYS
1000 Birch Ridge Dr., Raleigh NC, 27610

2012 STANDARD SPECIFICATIONS	
RIGHT OF WAY DATE: NOVEMBER 22, 2011	G. E. BREW PE PROJECT ENGINEER
LETTING DATE: DECEMBER 18, 2012	W.T. BEST PROJECT DESIGN ENGINEER

HYDRAULICS ENGINEER

Gregory E. Brew 9/27/12
SIGNATURE: P.E.

ROADWAY DESIGN ENGINEER

9-24-12
Gregory E. Brew
SIGNATURE: P.E.

DIVISION OF HIGHWAYS
STATE OF NORTH CAROLINA

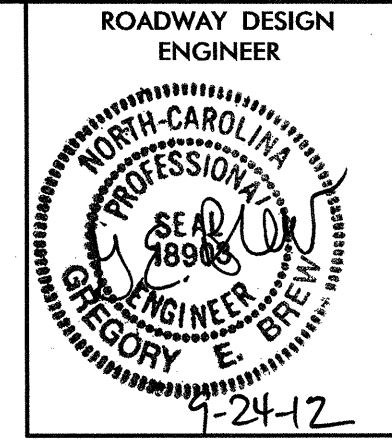

INDEX OF SHEETS

SHEET NUMBER	SHEET
1	TITLE SHEET
1-A	INDEX OF SHEETS, GENERAL NOTES, AND LIST OF STANDARD DRAWINGS
1-B	CONVENTIONAL SYMBOLS
1-C	SURVEY CONTROL SHEET
2	PAVEMENT SCHEDULE, TYPICAL SECTIONS, AND WEDGING DETAILS
3	SUMMARY OF QUANTITIES
3-A THRU 3-B	SUMMARY OF DRAINAGE QUANTITIES, GUARDRAIL SUMMARY, EARTHWORK SUMMARY, AND ASPHALT PAVEMENT REMOVAL SUMMARY
4	PLAN SHEET
5	PROFILE SHEET
TMP-1 THRU TMP-2	TRAFFIC CONTROL PLANS
RF-1 THRU RF-2	REFORESTATION PLANS
EC-1 THRU EC-5	EROSION CONTROL PLANS
UO-1 THRU UO-2	UTILITIES PLANS
X-1A THRU X-7	CROSS-SECTIONS
S-1 THRU S-28	STRUCTURE PLANS

2012 ROADWAY ENGLISH STANDARD DRAWINGS

The following Roadway Standards as appear in "Roadway Standard Drawings" Highway Design Branch - N. C. Department of Transportation - Raleigh, N. C., Dated January, 2012 are applicable to this project and by reference hereby are considered a part of these plans:

STD.NO.	TITLE
DIVISION 2 - EARTHWORK	
200.03	Method of Clearing - Method III
225.02	Guide for Grading Subgrade - Secondary and Local
225.04	Method of Obtaining Superelevation - Two Lane Pavement
DIVISION 3 - PIPE CULVERTS	
300.01	Method of Pipe Installation
DIVISION 4 - MAJOR STRUCTURES	
422.11	Reinforced Bridge Approach Fills - Sub Regional Tier
DIVISION 5 - SUBGRADE, BASES AND SHOULDERS	
560.01	Method of Shoulder Construction - High Side of Superelevated Curve - Method I
DIVISION 6 - ASPHALT BASES AND PAVEMENTS	
654.01	Pavement Repairs
DIVISION 8 - INCIDENTALS	
840.00	Concrete Base Pad for Drainage Structures
840.29	Frames and Narrow Slot Flat Grates
840.35	Traffic Bearing Grated Drop Inlet - for Cast Iron Double Frame and Grates
840.46	Traffic Bearing Precast Drainage Structure
840.66	Drainage Structure Steps
846.01	Concrete Curb, Gutter and Curb & Gutter
846.04	Drop Inlet Installation in Shoulder Berm Gutter
862.01	Guardrail Placement
862.02	Guardrail Installation
862.03	Structure Anchor Units
876.01	Rip Rap in Channels
876.02	Guide for Rip Rap at Pipe Outlets

GENERAL NOTES

2012 SPECIFICATIONS

EFFECTIVE: 01/17/12
REVISED: 07/30/12

GRADING AND SURFACING OR RESURFACING AND WIDENING:
THE GRADE LINES SHOWN DENOTE THE FINISHED ELEVATION OF THE PROPOSED SURFACING AT GRADE POINTS SHOWN ON THE TYPICAL SECTIONS. WHERE NO GRADE LINES ARE SHOWN, THE PROFILES SHOWN DENOTE THE TOP ELEVATION OF THE EXISTING PAVEMENT ALONG THE CENTER LINE OF SURVEY ON WHICH THE PROPOSED RESURFACING WILL BE PLACED. GRADE LINES MAY BE ADJUSTED BY THE ENGINEER IN ORDER TO SECURE A PROPER TIE-IN.

CLEARING:
CLEARING ON THIS PROJECT SHALL BE PERFORMED TO THE LIMITS ESTABLISHED BY METHOD III.

SUPERELEVATION:
ALL CURVES ON THIS PROJECT SHALL BE SUPERELEVATED IN ACCORDANCE WITH STD. NO. 225.04 USING THE RATE OF SUPERELEVATION AND RUNOFF SHOWN ON THE PLANS. SUPERELEVATION IS TO BE REVOLVED ABOUT THE GRADE POINTS SHOWN ON THE TYPICAL SECTIONS.

SHOULDER CONSTRUCTION:
ASPHALT, EARTH, AND CONCRETE SHOULDER CONSTRUCTION ON THE HIGH SIDE OF SUPERELEVATED CURVES SHALL BE IN ACCORDANCE WITH STD. NO. 560.01.

GUARDRAIL:
THE GUARDRAIL LOCATIONS SHOWN ON THE PLANS MAY BE ADJUSTED DURING CONSTRUCTION AS DIRECTED BY THE ENGINEER. THE CONTRACTOR SHOULD CONSULT WITH THE ENGINEER PRIOR TO ORDERING GUARDRAIL MATERIAL.

TEMPORARY SHORING:
SHORING REQUIRED FOR THE MAINTENANCE OF TRAFFIC WILL BE PAID FOR AS "EXTRA WORK" IN ACCORDANCE WITH SECTION 104-7.

SUBSURFACE PLANS:
NO SUBSURFACE PLANS ARE AVAILABLE ON THIS PROJECT. THE CONTRACTOR SHOULD MAKE HIS OWN INVESTIGATION AS TO THE SUBSURFACE CONDITIONS.

END BENTS:
THE ENGINEER SHALL CHECK THE STRUCTURE END BENT PLANS, DETAILS, AND CROSS-SECTION PRIOR TO SETTING OF THE SLOPE STAKES FOR THE EMBANKMENT OR EXCAVATION APPROACHING A BRIDGE.

UTILITIES:
UTILITY OWNERS ON THIS PROJECT ARE WINDSTREAM COMMUNICATIONS, UNION POWER, TIME WARNER CABLE, PIEDMONT NATURAL GAS, AND WATER AND SEWER AUTHORITY OF CABARRUS COUNTY. ANY RELOCATION OF EXISTING UTILITIES WILL BE ACCOMPLISHED BY OTHERS.















RIGHT-OF-WAY MARKERS:
ALL RIGHT-OF-WAY MARKERS ON THIS PROJECT SHALL BE PLACED BY OTHERS.

Note: Not to Scale











*S.U.E. = Subsurface Utility Engineering

CONVENTIONAL PLAN SHEET SYMBOLS











BOUNDARIES AND PROPERTY:

State Line	-----
County Line	-----
Township Line	-----
City Line	-----
Reservation Line	-----
Property Line	-----
Existing Iron Pin	----- 
Property Corner	----- 
Property Monument	----- 
Parcel/Sequence Number	----- 
Existing Fence Line	----- 
Proposed Woven Wire Fence	----- 
Proposed Chain Link Fence	----- 
Proposed Barbed Wire Fence	----- 
Existing Wetland Boundary	----- 
Proposed Wetland Boundary	----- 
Existing Endangered Animal Boundary	----- 
Existing Endangered Plant Boundary	----- 
Known Soil Contamination: Area or Site	----- 
Potential Soil Contamination: Area or Site	----- 





BUILDINGS AND OTHER CULTURE:

Gas Pump Vent or U/G Tank Cap	----- 
Sign	----- 
Well	----- 
Small Mine	----- 
Foundation	----- 
Area Outline	----- 
Cemetery	----- 
Building	----- 
School	----- 
Church	----- 
Dam	----- 



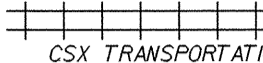

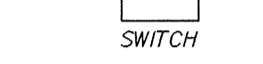







HYDROLOGY:

Stream or Body of Water	-----
Hydro, Pool or Reservoir	----- 
Jurisdictional Stream	----- 
Buffer Zone 1	----- 
Buffer Zone 2	----- 
Flow Arrow	----- 
Disappearing Stream	----- 
Spring	----- 
Wetland	----- 
Proposed Lateral, Tail, Head Ditch	----- 
False Sump	----- 

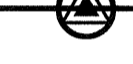
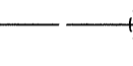





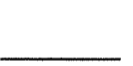
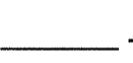
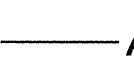



RAILROADS:

Standard Gauge	----- 
RR Signal Milepost	----- 
Switch	----- 
RR Abandoned	----- 
RR Dismantled	----- 

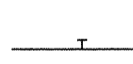
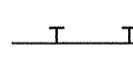
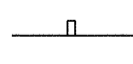
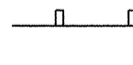
RIGHT OF WAY:





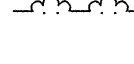

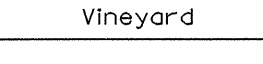
Baseline Control Point	----- 
Existing Right of Way Marker	----- 
Existing Right of Way Line	----- 
Proposed Right of Way Line	----- 
Proposed Right of Way Line with Iron Pin and Cap Marker	----- 
Proposed Right of Way Line with Concrete or Granite RW Marker	----- 
Proposed Control of Access Line with Concrete C/A Marker	----- 
Existing Control of Access	----- 
Proposed Control of Access	----- 
Existing Easement Line	----- 
Proposed Temporary Construction Easement	----- 
Proposed Temporary Drainage Easement	----- 
Proposed Permanent Drainage Easement	----- 
Proposed Permanent Drainage / Utility Easement	----- 
Proposed Permanent Utility Easement	----- 
Proposed Temporary Utility Easement	----- 
Proposed Aerial Utility Easement	----- 

ROADS AND RELATED FEATURES:

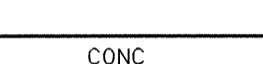
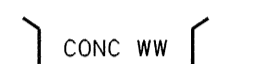

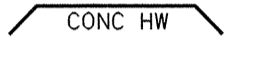

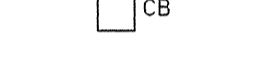
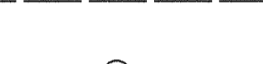





Existing Edge of Pavement	-----
Existing Curb	----- 
Proposed Slope Stakes Cut	----- 
Proposed Slope Stakes Fill	----- 
Proposed Curb Ramp	----- 
Existing Metal Guardrail	----- 
Proposed Guardrail	----- 
Existing Cable Guiderail	----- 
Proposed Cable Guiderail	----- 
Equality Symbol	----- 
Pavement Removal	----- 
VEGETATION:	
Single Tree	----- 
Single Shrub	----- 
Hedge	----- 
Woods Line	----- 

Orchard	----- 
Vineyard	----- 





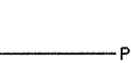



EXISTING STRUCTURES:

MAJOR:	
Bridge, Tunnel or Box Culvert	----- 
Bridge Wing Wall, Head Wall and End Wall	----- 
MINOR:	
Head and End Wall	----- 
Pipe Culvert	----- 
Footbridge	----- 
Drainage Box: Catch Basin, DI or JB	----- 
Paved Ditch Gutter	----- 
Storm Sewer Manhole	----- 
Storm Sewer	----- 





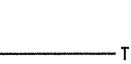
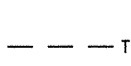
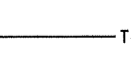
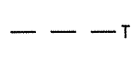
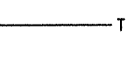

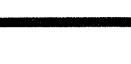
UTILITIES:

POWER:	
Existing Power Pole	----- 
Proposed Power Pole	----- 
Existing Joint Use Pole	----- 
Proposed Joint Use Pole	----- 
Power Manhole	----- 
Power Line Tower	----- 
Power Transformer	----- 
U/G Power Cable Hand Hole	----- 
H-Frame Pole	----- 
Recorded U/G Power Line	----- 
Designated U/G Power Line (S.U.E.*)	----- 





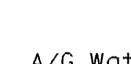

TELEPHONE:

Existing Telephone Pole	----- 
Proposed Telephone Pole	----- 
Telephone Manhole	----- 
Telephone Booth	----- 
Telephone Pedestal	----- 
Telephone Cell Tower	----- 
U/G Telephone Cable Hand Hole	----- 
Recorded U/G Telephone Cable	----- 
Designated U/G Telephone Cable (S.U.E.*)	----- 
Recorded U/G Telephone Conduit	----- 
Designated U/G Telephone Conduit (S.U.E.*)	----- 
Recorded U/G Fiber Optics Cable	----- 
Designated U/G Fiber Optics Cable (S.U.E.*)	----- 



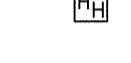

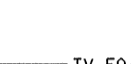
WATER:

Water Manhole	----- 
Water Meter	----- 
Water Valve	----- 
Water Hydrant	----- 
Recorded U/G Water Line	----- 
Designated U/G Water Line (S.U.E.*)	----- 
Above Ground Water Line	----- 



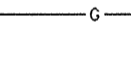
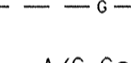

TV:

TV Satellite Dish	----- 
TV Pedestal	----- 
TV Tower	----- 
U/G TV Cable Hand Hole	----- 
Recorded U/G TV Cable	----- 
Designated U/G TV Cable (S.U.E.*)	----- 
Recorded U/G Fiber Optic Cable	----- 
Designated U/G Fiber Optic Cable (S.U.E.*)	----- 



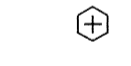
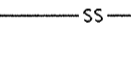

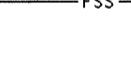

GAS:

Gas Valve	----- 
Gas Meter	----- 
Recorded U/G Gas Line	----- 
Designated U/G Gas Line (S.U.E.*)	----- 
Above Ground Gas Line	----- 

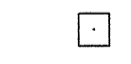
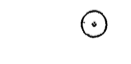
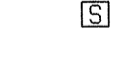
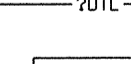
SANITARY SEWER:

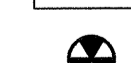
Sanitary Sewer Manhole	----- 
Sanitary Sewer Cleanout	----- 
U/G Sanitary Sewer Line	----- 
Above Ground Sanitary Sewer	----- 
Recorded SS Forced Main Line	----- 
Designated SS Forced Main Line (S.U.E.*)	----- 

MISCELLANEOUS:

Utility Pole	----- 
Utility Pole with Base	----- 
Utility Located Object	----- 
Utility Traffic Signal Box	----- 
Utility Unknown U/G Line	----- 
U/G Tank; Water, Gas, Oil	----- 
Underground Storage Tank, Approx. Loc.	----- 
A/G Tank; Water, Gas, Oil	----- 
Geoenvironmental Boring	----- 
U/G Test Hole (S.U.E.*)	----- 
Abandoned According to Utility Records	----- 
End of Information	----- 

SURVEY CONTROL SHEET FINAL PLANS

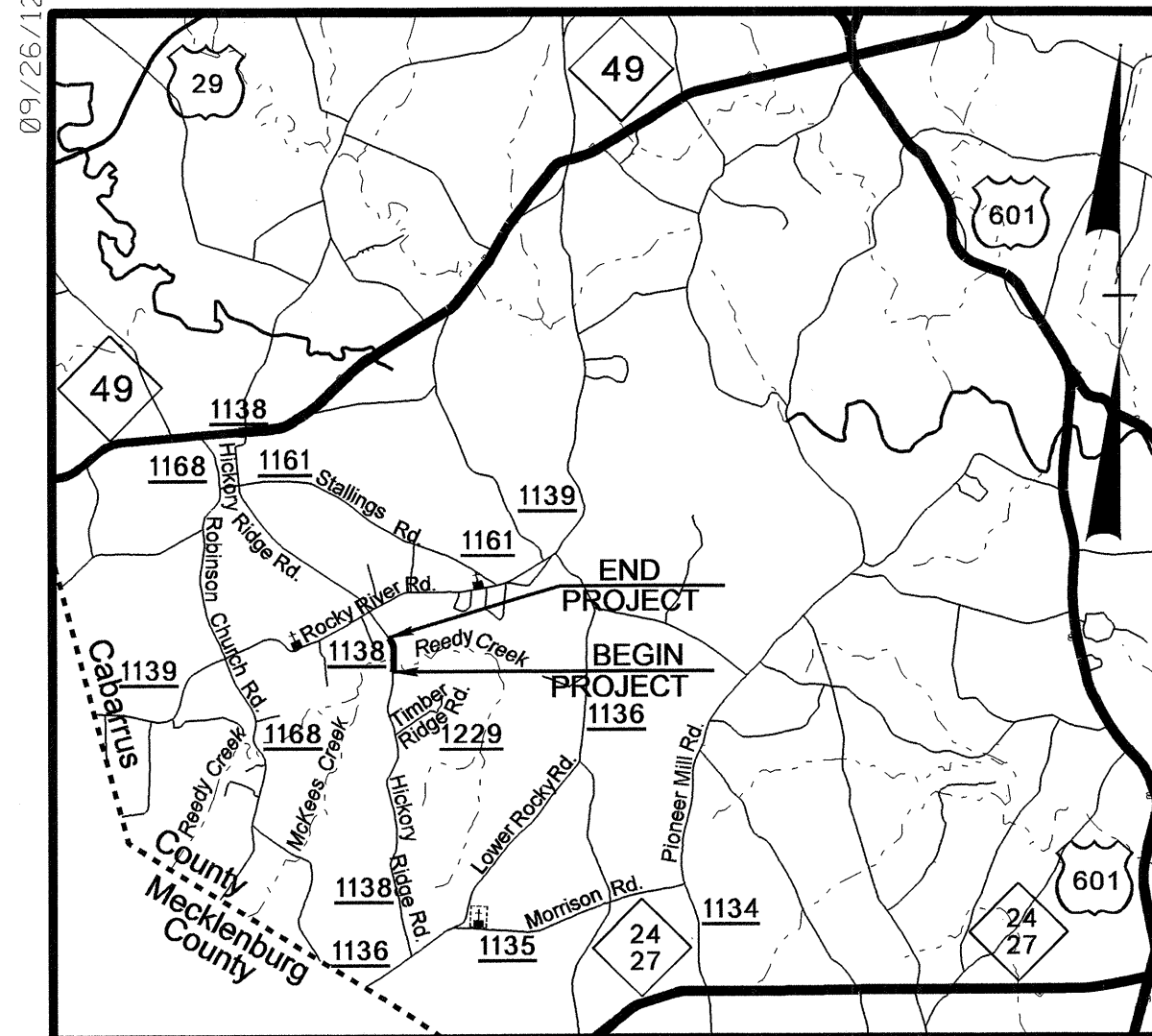

VICINITY MAP

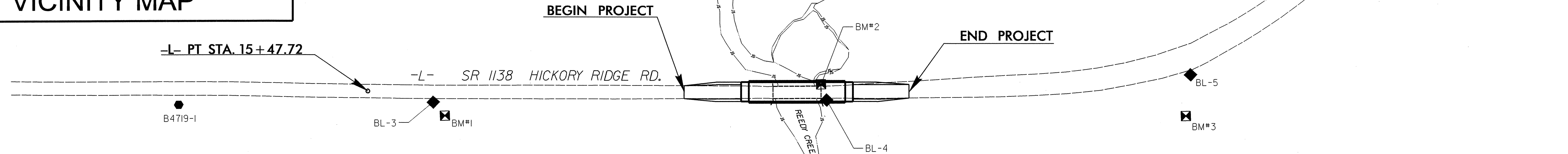
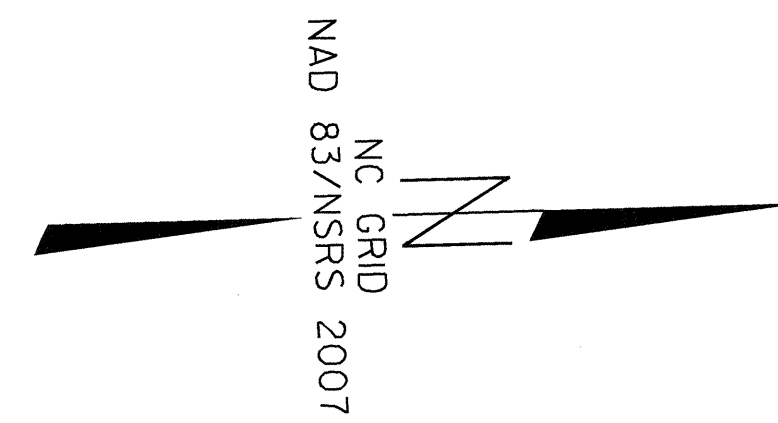

DATUM DESCRIPTION

THE LOCALIZED COORDINATE SYSTEM DEVELOPED FOR THIS PROJECT IS BASED ON THE STATE PLANE COORDINATES ESTABLISHED BY NCDOT FOR MONUMENT "B4719-1" WITH NAD 83/NSRS 2007 STATE PLANE GRID COORDINATES OF NORTHING: 564386.369(ft) EASTING: 1515394.058(ft) ELEVATION: 613.93(ft)

THE AVERAGE COMBINED GRID FACTOR USED ON THIS PROJECT (GROUND TO GRID) IS: 0.999849

THE N.C. LAMBERT GRID BEARING AND LOCALIZED HORIZONTAL GROUND DISTANCE FROM "B4719-1" TO -L- STATION 15+47.72 IS N2°30'36.85"W 295.277

ALL LINEAR DIMENSIONS ARE LOCALIZED HORIZONTAL DISTANCES VERTICAL DATUM USED IS NAVD 88

TYPE	STATION	NORTH	EAST
POT	10+00.00	564134.0537	1515359.8659
PC	14+88.29	564621.9629	1515379.0283
PT	15+47.72	564681.3628	1515381.1255
PC	25+27.62	565660.7784	1515411.8201
PT	29+16.33	566038.9135	1515337.2652

NOTES:

- THE CONTROL DATA FOR THIS PROJECT CAN BE FOUND ELECTRONICALLY BY SELECTING PROJECT CONTROL DATA AT:
[HTTP://WWW.NCDOT.ORG/DOH/PRECONSTRUCT/HIGHWAY/LOCATION/PROJECT/](http://www.ncdot.org/DOH/PRECONSTRUCT/HIGHWAY/LOCATION/PROJECT/)
THE FILES TO BE FOUND ARE AS FOLLOWS:
B4719_LS_CONTROL.TXT
B4719_LS_LOCAL.TXT
 - SITE CALIBRATION INFORMATION HAS NOT BEEN PROVIDED FOR THIS PROJECT. IF FURTHER INFORMATION IS NEEDED, PLEASE CONTACT THE LOCATION AND SURVEYS UNIT.
 - PROJECT CONTROL ESTABLISHED USING GLOBAL POSITIONING SYSTEM. NETWORK ESTABLISHED FROM NGS ONLINE POSITIONING SERVICE (OPUS) MONUMENTS USED OR SET FOR PROJECT CONTROL BY THE NCDOT LOCATION AND SURVEYS UNIT:
- INDICATES GEODETIC CONTROL MONUMENTS FOR HORIZONTAL CONTROL
 - INDICATES BASELINE MONUMENTS FOR HORIZONTAL PROJECT CONTROL
 - ⊠ INDICATES BENCHMARKS FOR VERTICAL PROJECT CONTROL

BL	POINT	DESC.	NORTH	EAST	ELEVATION	L STATION	OFFSET
1	B4719-1		564386.3690	1515394.0580	613.93	12+53.46	24.26 RT
3	BL-3		564782.5320	1515401.3070	584.09	16+49.47	17.00 RT
4	BL-4		565394.4720	1515416.0590	563.32	22+61.58	12.58 RT
5	BL-5		565961.9810	1515394.0800	577.62	28+25.42	25.39 RT

```

.....
BM1      ELEVATION = 582.64
N 564800      E 1515423
L STATION 16+68 38 RIGHT
R/R SPIKE IN POWER POLE
.....
BM2      ELEVATION = 563.10
N 565387      E 1515391
L STATION 22+53 12 LEFT
R/R SPIKE IN END WALL OF BRIDGE
.....
BM3      ELEVATION = 590.41
N 565953      E 1515458
L STATION 27+99 84 RIGHT
R/R SPIKE IN POWER POLE
.....

```

ALIGN	STATION	OFFSET	NORTH	EAST
L	20+40.00	-45.00	565174.8085	1515351.5678
L	20+40.00	-30.00	565174.3386	1515366.5605
L	20+40.00	30.00	565172.4591	1515426.5310
L	20+40.00	52.50	565171.7543	1515449.0200
L	23+90.00	-45.00	565524.6367	1515362.5313
L	23+90.00	-33.40	565524.2734	1515374.1247
L	23+90.00	26.64	565522.3925	1515434.1390
L	23+90.00	43.12	565521.8764	1515450.6083

NOTE: DRAWING NOT TO SCALE

09/26/12

26-SEP-2012 14:50
P:\Roadwork\Proj\B4719_1s_1C.dgn
\$\$\$\$\$SUPERVISOR\$\$\$\$\$

6/2/09

PAVEMENT SCHEDULE <small>(FINAL PAVEMENT DESIGN)</small>	
C1	PROP. APPROX. 3" ASPHALT CONCRETE SURFACE COURSE, TYPE S9.5B, AT AN AVERAGE RATE OF 168 LBS. PER SQ. YD. IN EACH OF TWO LAYERS.
C2	PROP. VAR. DEPTH ASPHALT CONCRETE SURFACE COURSE, TYPE S9.5B, AT AN AVERAGE RATE OF 112 LBS. PER SQ. YD. PER 1" DEPTH. TO BE PLACED IN LAYERS NOT TO EXCEED 1 1/2" IN DEPTH.
D1	PROP. APPROX. 2 1/2" ASPHALT CONCRETE INTERMEDIATE COURSE, TYPE I19.0B, AT AN AVERAGE RATE OF 285 LBS. PER SQ. YD.
D2	PROP. VAR. DEPTH ASPHALT CONCRETE INTERMEDIATE COURSE, TYPE I19.0B, AT AN AVERAGE RATE OF 114 LBS. PER SQ. YD. PER 1" DEPTH, TO BE PLACED IN LAYERS NOT LESS THAN 2 1/2" IN DEPTH OR GREATER THAN 4" IN DEPTH.
E1	PROP. APPROX. 5" ASPHALT CONCRETE BASE COURSE, TYPE B25.0B, AT AN AVERAGE RATE OF 570 LBS. PER SQ. YD.
E2	PROP. VAR. DEPTH ASPHALT CONCRETE BASE COURSE, TYPE B25.0B, AT AN AVERAGE RATE OF 114 LBS. PER SQ. YD. PER 1" DEPTH. TO BE PLACED IN LAYERS NOT LESS THAN 3" IN DEPTH OR GREATER THAN 5 1/2" IN DEPTH.
R1	SHOULDER BERM GUTTER.

T	EARTH MATERIAL.
U	EXISTING PAVEMENT.
W	VARIABLE DEPTH ASPHALT PAVEMENT. (WEDGING)

NOTE: PAVEMENT EDGE SLOPES ARE 1:1 UNLESS SHOWN OTHERWISE.

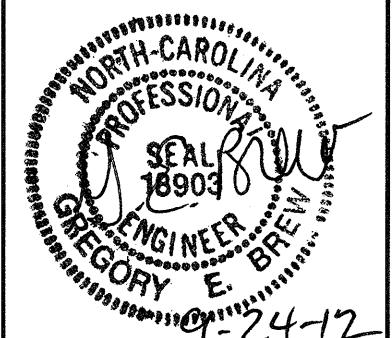
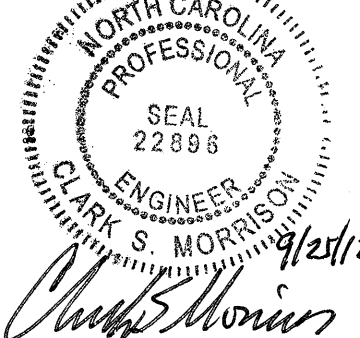
PROJECT REFERENCE NO. B-4719	SHEET NO. 2
ROADWAY DESIGN ENGINEER 	PAVEMENT DESIGN ENGINEER 

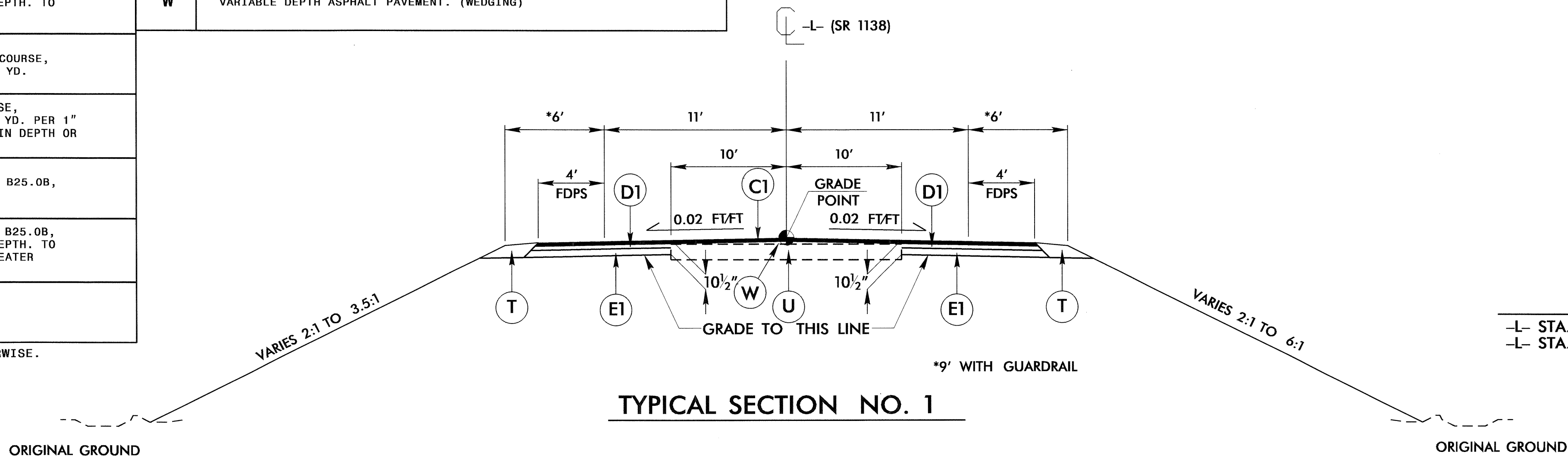

USE TYPICAL SECTION NO. 1
 -L- STA. 20+40.00 TO 20+90.00
 -L- STA. 23+08.00 TO 23+90.00

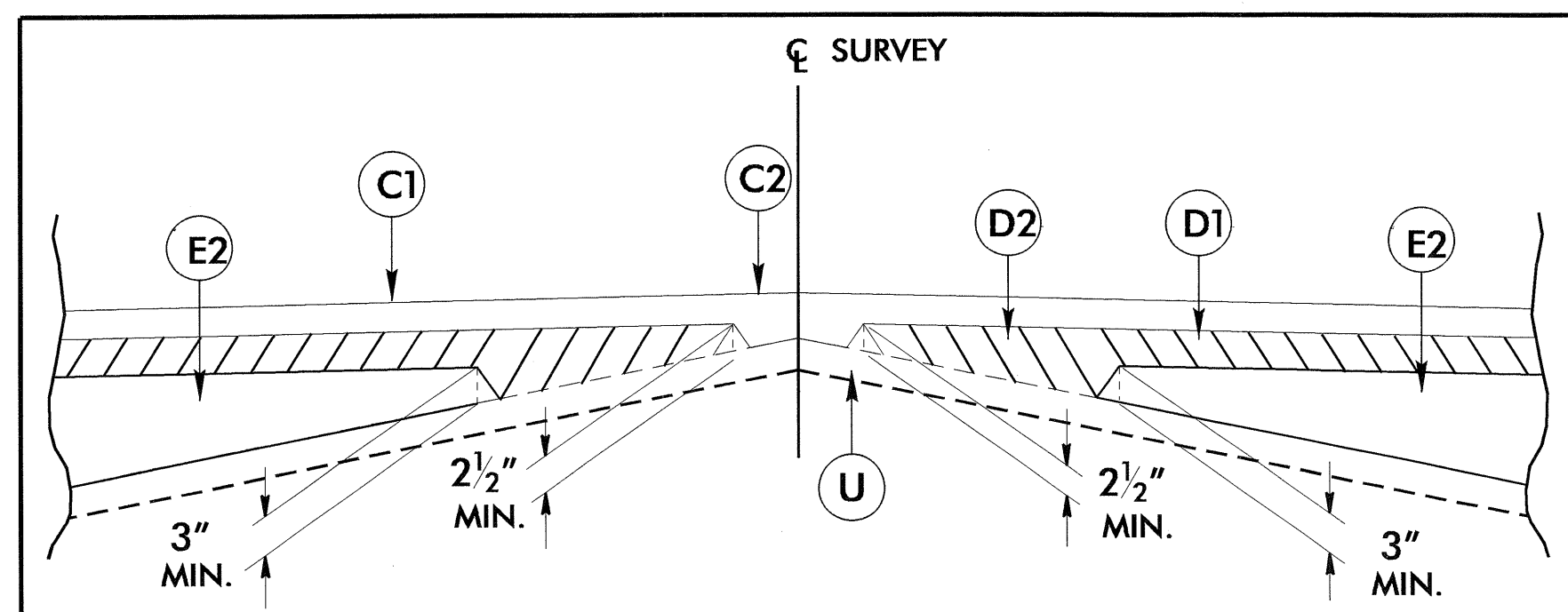

Detail Showing Method of Wedging

ORIGINAL GROUND

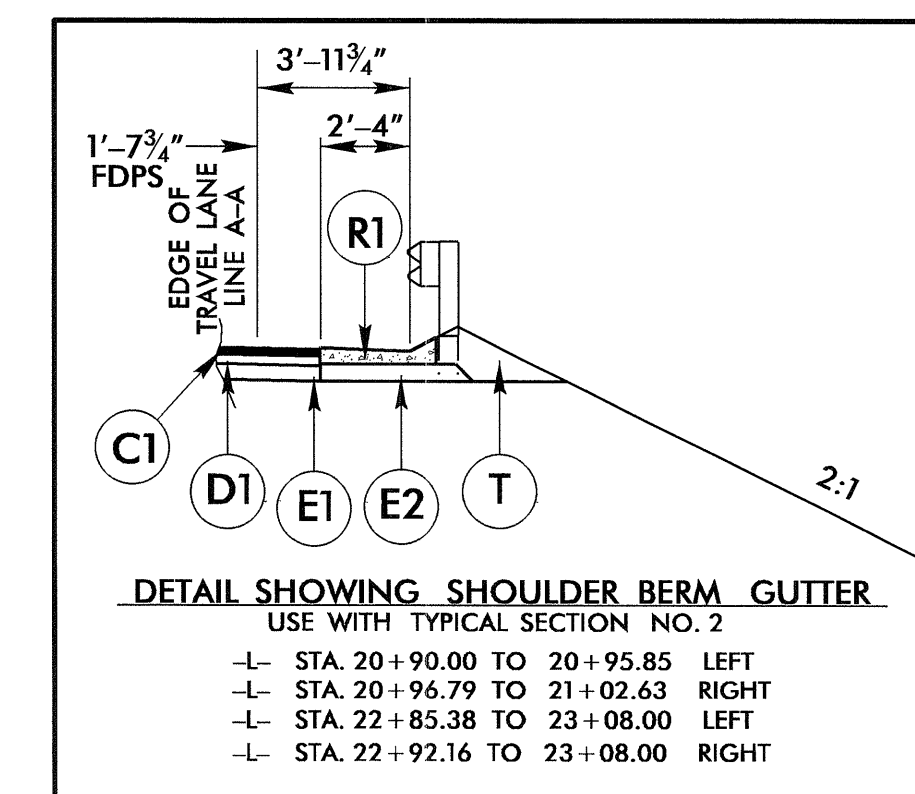
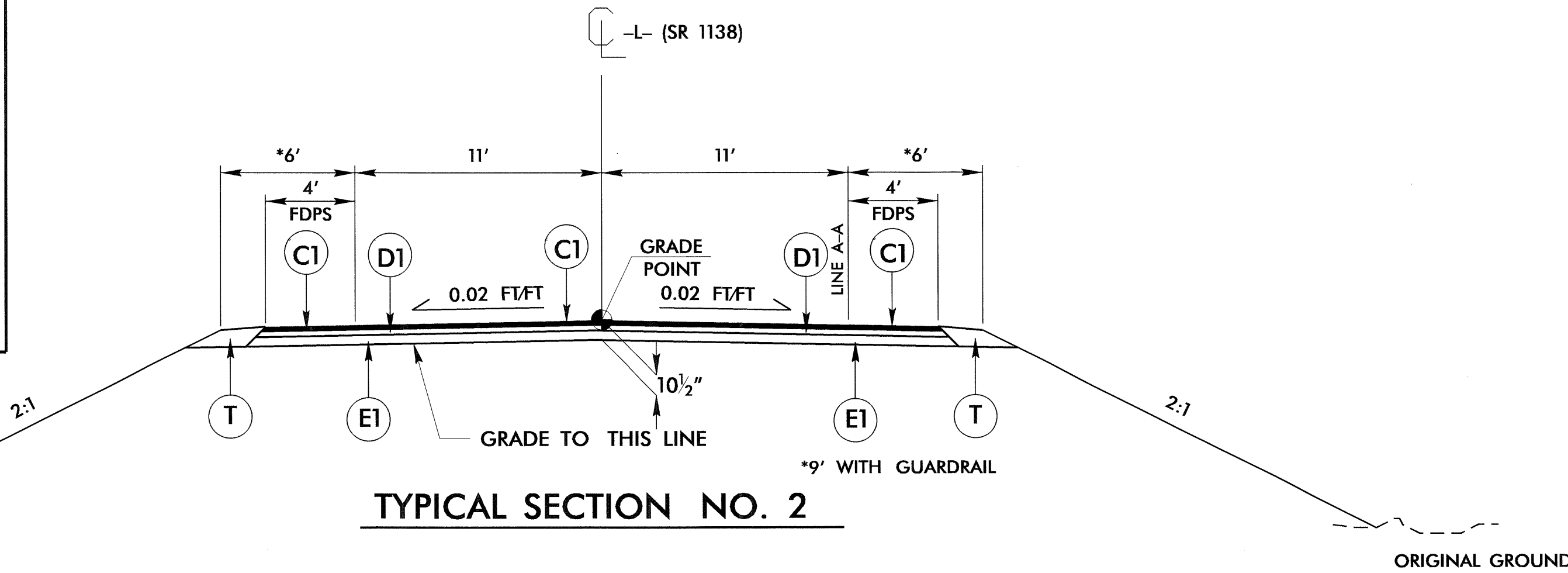

DETAIL SHOWING SHOULDER BERM GUTTER
 USE WITH TYPICAL SECTION NO. 2
 -L- STA. 20+90.00 TO 20+95.85 LEFT
 -L- STA. 20+96.79 TO 21+02.63 RIGHT
 -L- STA. 22+85.38 TO 23+08.00 LEFT
 -L- STA. 22+92.16 TO 23+08.00 RIGHT

ORIGINAL GROUND

USE TYPICAL SECTION NO. 2
 -L- STA. 20+90.00 TO 21+10.21 (BEGIN BRIDGE)
 -L- STA. 22+77.80 (END BRIDGE) TO 23+08.00

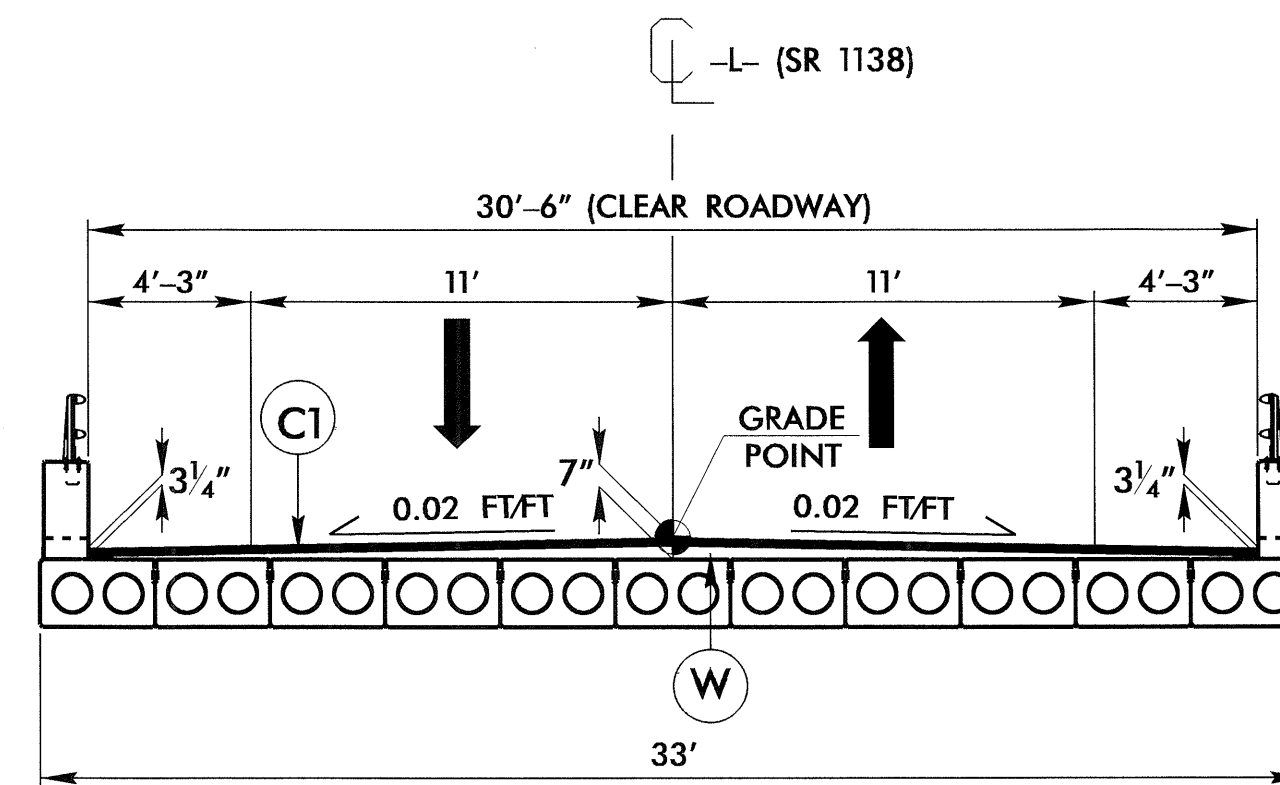

TYPICAL SECTION ON STRUCTURE

-L- STA. 21+10.21 TO 22+77.80

21-SEP-2012 08:43
 R:\Roadway\proj\B-4719_r.dwg - tjp.dgn
 \$\$\$\$SUSTAINABLE\$\$\$\$

STATE OF NORTH CAROLINA
DIVISION OF HIGHWAYS

SUMMARY OF QUANTITIES

STATE OF NORTH CAROLINA
DIVISION OF HIGHWAYS
ROADWAY SUMMARY OF QUANTITIES FOR CONTRACT - C203018

ItemNumber	Sec #	Quantity	Unit	Description	ItemNumber	Sec #	Quantity	Unit	Description
0000100000-N	800	Lump Sum		MOBILIZATION	3030000000-E	862	125	LF	STEEL BM GUARDRAIL
0000400000-N	801	Lump Sum		CONSTRUCTION SURVEYING	3150000000-N	862	5	EA	ADDITIONAL GUARDRAIL POSTS
0030000000-N	SP	Lump Sum		BRIDGE APPROACH FILL - SUB REGIONAL TIER, STATION ***** (21+94)	3165000000-N	SP	4	EA	GUARDRAIL ANCHOR UNITS, TYPE ***** (350, TL-2)
0043000000-N	226	Lump Sum		GRADING	3215000000-N	862	4	EA	GUARDRAIL ANCHOR UNITS, TYPE III
0050000000-E	226	1	ACR	SUPPLEMENTARY CLEARING & GRUB-BING	3628000000-E	876	8	TON	RIP RAP, CLASS I
0057000000-E	226	50	CY	UNDERCUT EXCAVATION	3635000000-E	876	71	TON	RIP RAP, CLASS II
0134000000-E	240	175	CY	DRAINAGE DITCH EXCAVATION	3649000000-E	876	2	TON	RIP RAP, CLASS B
0196000000-E	270	160	SY	GEOTEXTILE FOR SOIL STABILIZATION	3656000000-E	876	1,342	SY	GEOTEXTILE FOR DRAINAGE
0318000000-E	300	6	TON	FOUNDATION CONDITIONING MATERIAL, MINOR STRUCTURES	4400000000-E	1110	366	SF	WORK ZONE SIGNS (STATIONARY)
0320000000-E	300	16	SY	FOUNDATION CONDITIONING GEOTEXTILE	4410000000-E	1110	119	SF	WORK ZONE SIGNS (BARRICADE MOUNTED)
0335200000-E	305	48	LF	15" DRAINAGE PIPE	4445000000-E	1145	88	LF	BARRICADES (TYPE III)
0995000000-E	340	22	LF	PIPE REMOVAL	6000000000-E	1605	700	LF	TEMPORARY SILT FENCE
1099500000-E	505	25	CY	SHALLOW UNDERCUT	6006000000-E	1610	225	TON	STONE FOR EROSION CONTROL, CLASS A
1099700000-E	505	50	TON	CLASS IV SUBGRADE STABILIZATION	6009000000-E	1610	10	TON	STONE FOR EROSION CONTROL, CLASS B
1220000000-E	545	50	TON	INCIDENTAL STONE BASE	6012000000-E	1610	305	TON	SEDIMENT CONTROL STONE
1330000000-E	607	130	SY	INCIDENTAL MILLING	6015000000-E	1615	1	ACR	TEMPORARY MULCHING
1489000000-E	610	170	TON	ASPHALT CONC BASE COURSE, TYPE B25.0B	6018000000-E	1620	50	LB	SEED FOR TEMPORARY SEEDING
1498000000-E	610	140	TON	ASPHALT CONC INTERMEDIATE COURSE, TYPE I19.0B	6021000000-E	1620	1.25	TON	FERTILIZER FOR TEMPORARY SEEDING
1519000000-E	610	200	TON	ASPHALT CONC SURFACE COURSE, TYPE S9.5B	6024000000-E	1622	200	LF	TEMPORARY SLOPE DRAINS
1575000000-E	620	27	TON	ASPHALT BINDER FOR PLANT MIX	6029000000-E	SP	100	LF	SAFETY FENCE
1693000000-E	654	25	TON	ASPHALT PLANT MIX, PAVEMENT REPAIR	6030000000-E	1630	100	CY	SILT EXCAVATION
2286000000-N	840	2	EA	MASONRY DRAINAGE STRUCTURES	6036000000-E	1631	1,500	SY	MATTING FOR EROSION CONTROL
2367000000-N	840	2	EA	FRAME WITH TWO GRATES, STD 840.29	6037000000-E	SP	480	SY	COIR FIBER MAT
2556000000-E	846	60	LF	SHOULDER BERM GUTTER	6042000000-E	1632	150	LF	1/4" HARDWARE CLOTH
					6048000000-E	SP	50	SY	FLOATING TURBIDITY CURTAIN
					6070000000-N	1639	12	EA	SPECIAL STILLING BASINS
					6071010000-E	SP	45	LF	WATTLE
					6071012000-E	SP	120	LF	COIR FIBER WATTLE
					6071020000-E	SP	15	LB	POLYACRYLAMIDE (PAM)
					6071030000-E	1640	75	LF	COIR FIBER BAFFLE
					6071050000-E	SP	1	EA	*** SKIMMER (1-1/2")
					6084000000-E	1660	1	ACR	SEEDING & MULCHING
					6087000000-E	1660	0.5	ACR	MOWING
					6090000000-E	1661	50	LB	SEED FOR REPAIR SEEDING
					6093000000-E	1661	0.25	TON	FERTILIZER FOR REPAIR SEEDING
					6096000000-E	1662	50	LB	SEED FOR SUPPLEMENTAL SEEDING
					6108000000-E	1665	0.75	TON	FERTILIZER TOPDRESSING
					6114500000-N	1667	10	MHR	SPECIALIZED HAND MOWING
					6117000000-N	SP	18	EA	RESPONSE FOR EROSION CONTROL
					6126000000-E	SP	0.07	ACR	STREAMBANK REFORESTATION

5/28/99

21-SEP-2012 08:42
R:\Projects\2012\B-4719_Rdy_sum.dgn
8:42:11 PM

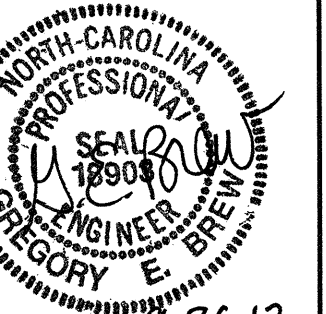
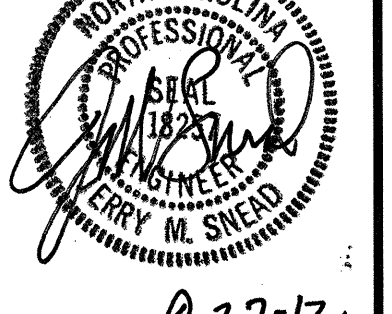
PROJECT REFERENCE NO.	SHEET NO.
B-4719	4
R/W SHEET NO.	4
ROADWAY DESIGN ENGINEER	HYDRAULICS ENGINEER
	
9-26-12	9-27-12

NAD 83/NSRS 2007

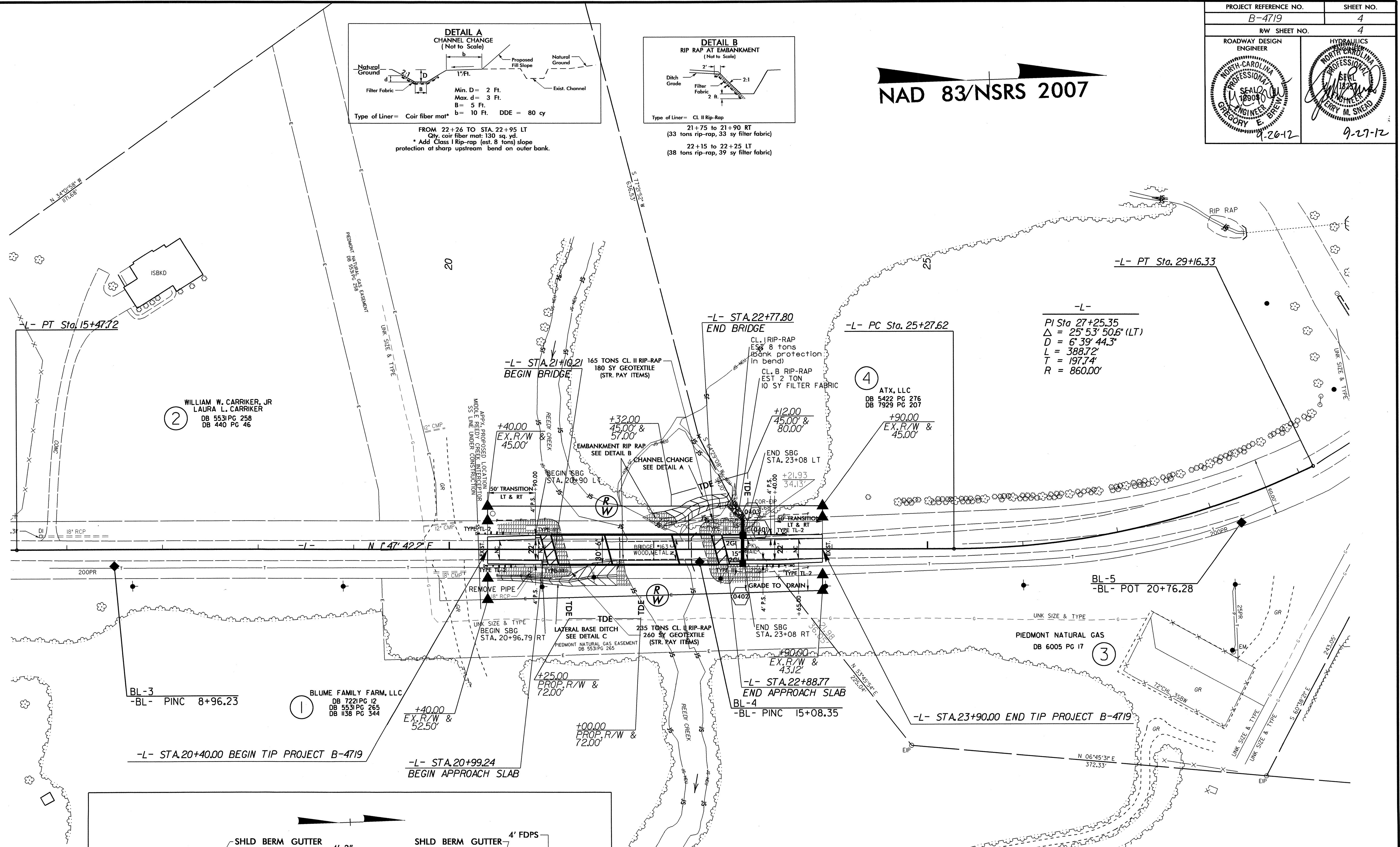
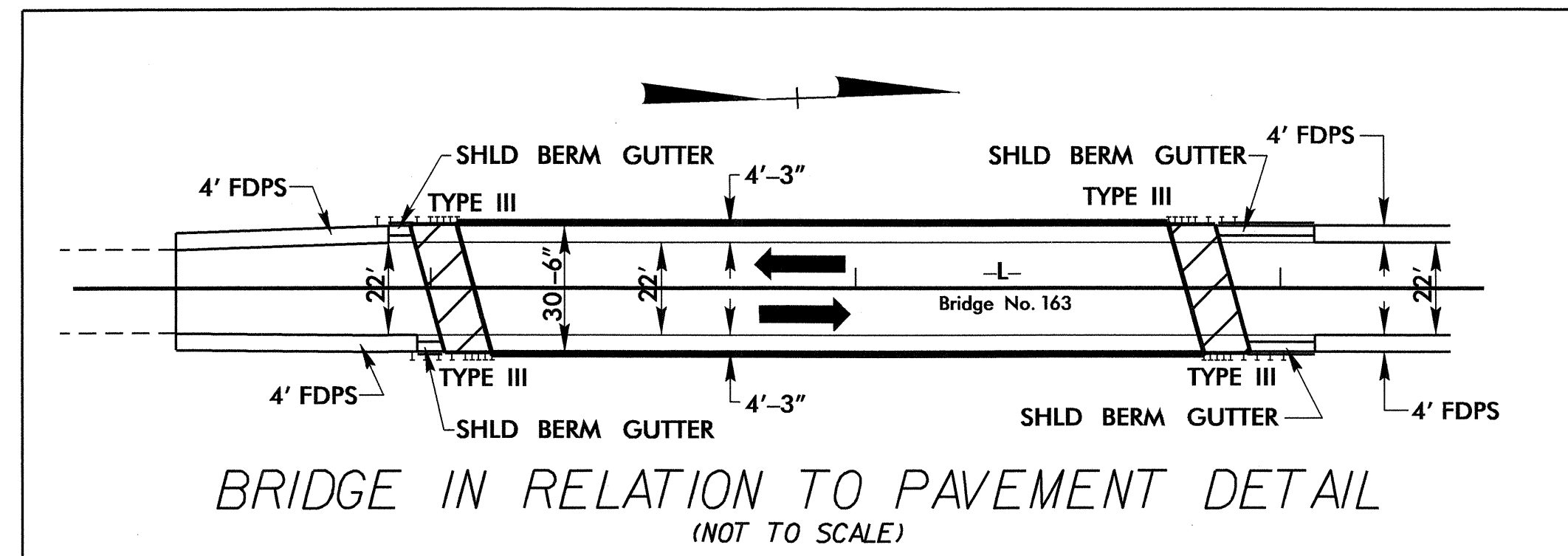
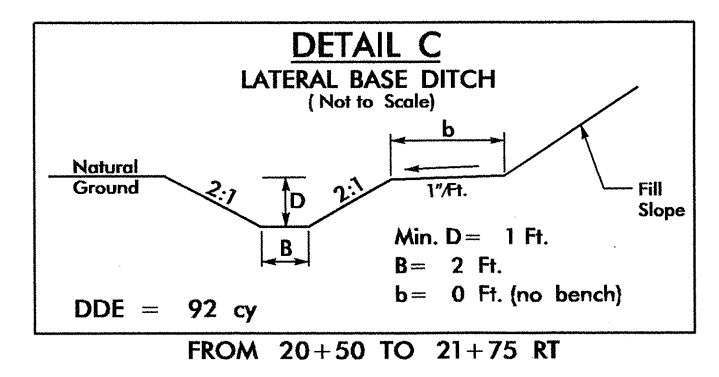
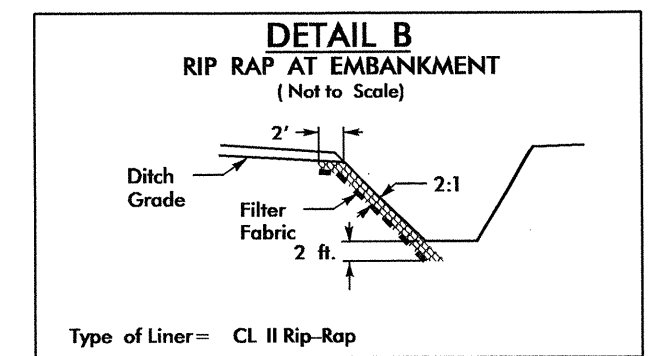
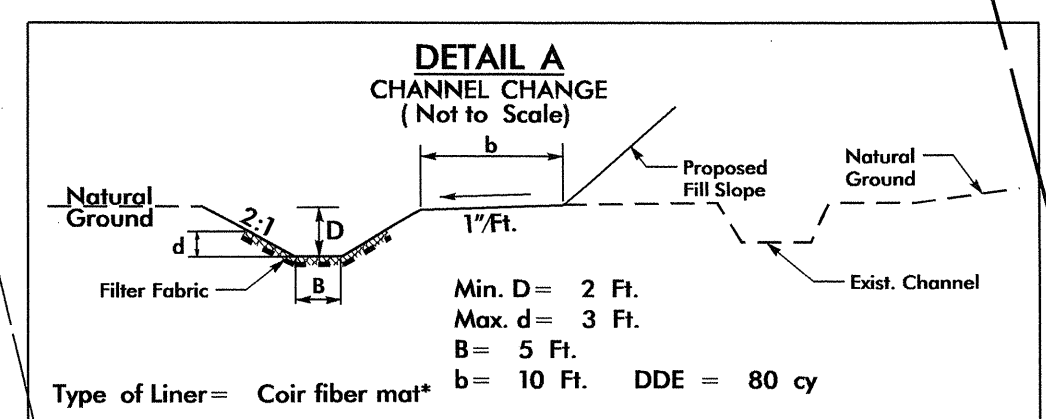

 BRIDGE APPROACH SLAB

REVISIONS

8/17/09
 26-SEP-2012 12:11 PM B-4719_Rdy_psh.dgn
 633831737814161333

5/14/99

PROJECT REFERENCE NO. B-4719	SHEET NO. 5
ROADWAY DESIGN ENGINEER GREGORY E. BIBLE 9-27-12	HYDRAULICS ENGINEER COURTNEY M. SWEED 9-27-12

BRIDGE HYDRAULIC DATA

DESIGN DISCHARGE = 4300 CFS
 DESIGN FREQUENCY = 5 yr +/- YRS
 DESIGN HW ELEVATION = 564.3 FT
 BASE DISCHARGE = 8100 CFS
 BASE FREQUENCY = 100 YRS
 BASE HW ELEVATION = 568.3 FT
 OVERTOPPING DISCHARGE = 4300 CFS
 OVERTOPPING FREQUENCY = 5 +/- YRS
 OVERTOPPING ELEVATION = 564.3 FT

DATE OF SURVEY = 6/1/11
 W.S. ELEVATION AT DATE OF SURVEY = 553.0
 * MAINTAIN EXISTING LEVEL OF SERVICE

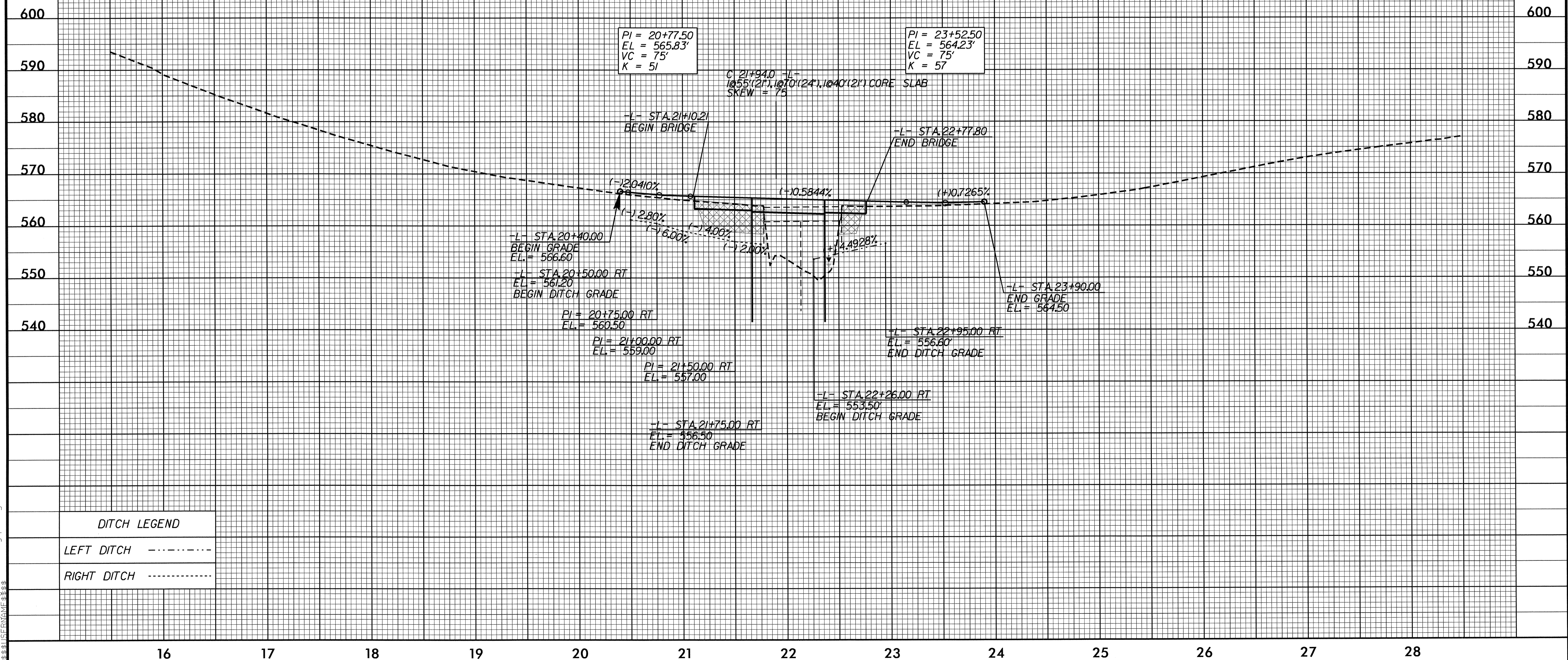

DITCH LEGEND

LEFT DITCH	-----
RIGHT DITCH	-----

27-SEP-2012 09:28 B:\PROJECTS\B-4719_Rdy-pl.dgn