

TIP PROJECT: B-4656

CONTRACT: C202235

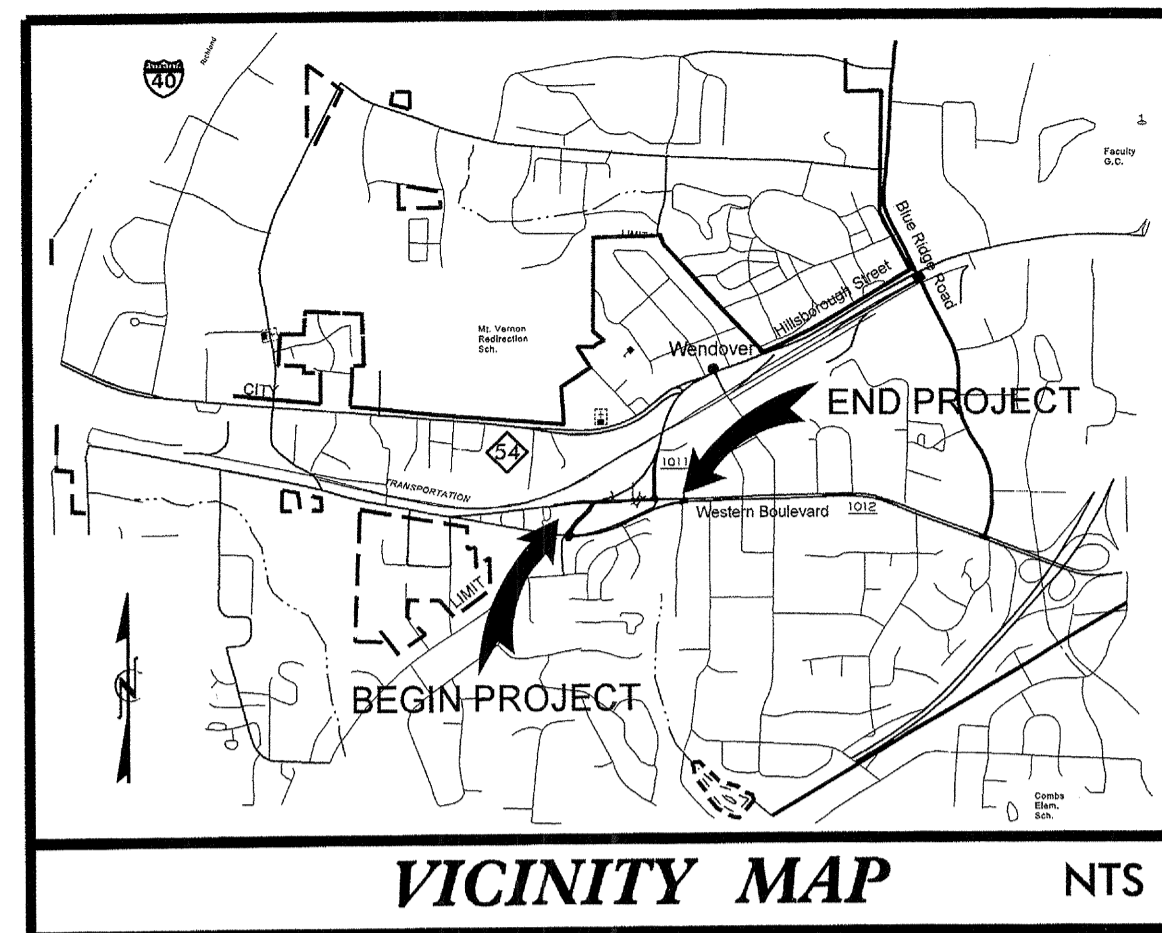

FINAL PLANS

STATE OF NORTH CAROLINA
DIVISION OF HIGHWAYS

WAKE COUNTY

**LOCATION: BRIDGE No. 492 OVER SR 1012 (WESTERN BLVD.)
ON SR 1011 (HILLSBOROUGH ST.)**

TYPE OF WORK: GRADING, PAVING, DRAINAGE, STRUCTURE REMOVAL AND SIGNALS

STATE	STATE PROJECT REFERENCE NO.	SHEET NO.	TOTAL SHEETS
N.C.	B-4656	1	
STATE PROJ. NO.	F.A. PROJ. NO.	DESCRIPTION	
33819.1.1	BRSTP-1011(8)	PE	
33819.2.1	BRSTP-1011(8)	R/W & UTIL.	
33819.3.1	BRSTP-1011(8)	CONST.	

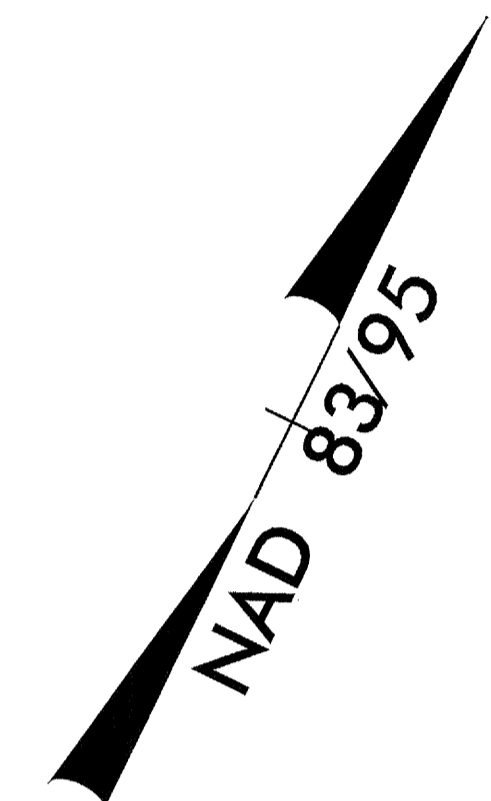
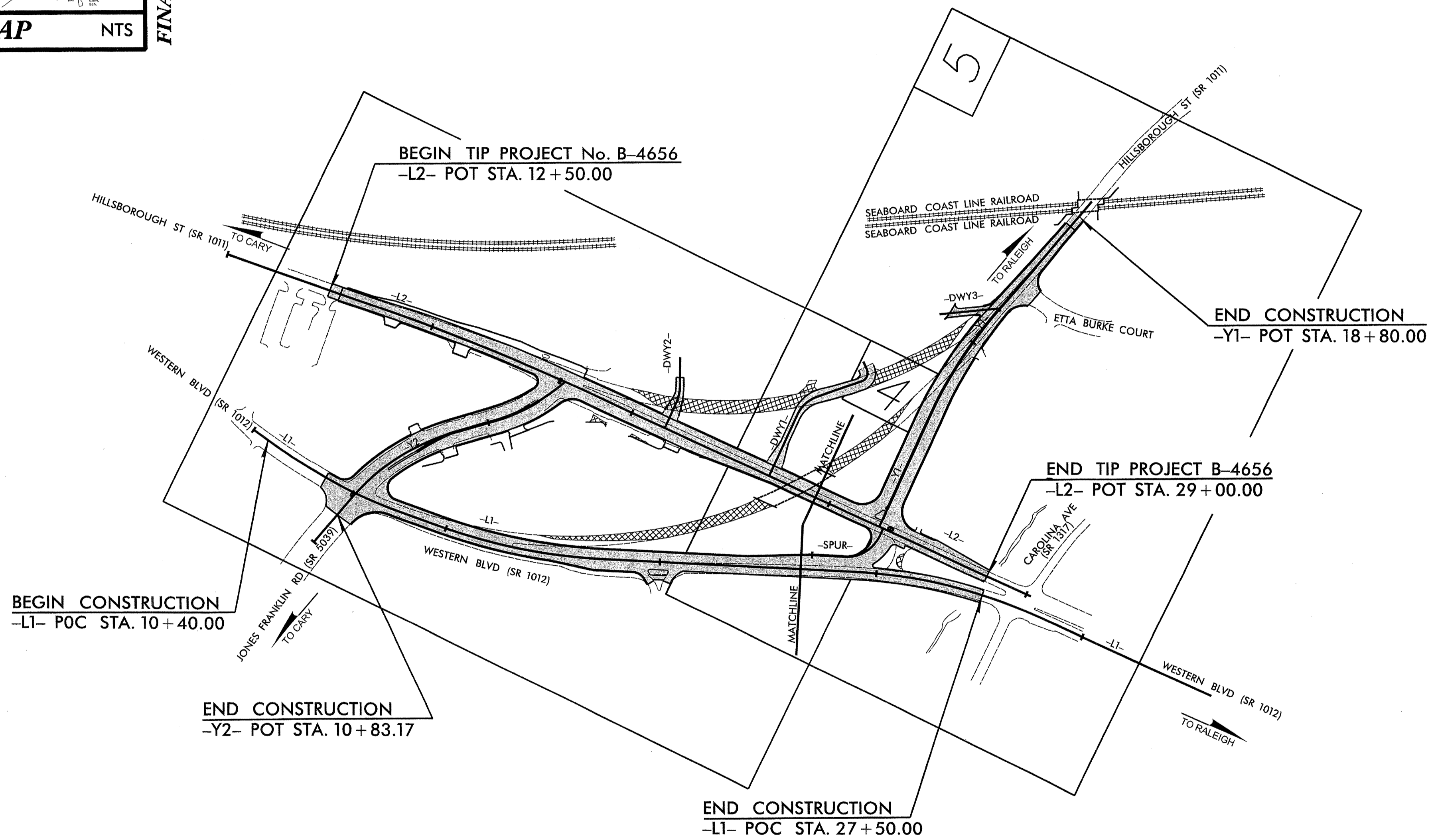

NCDOT CONTACT: BRENDA L. MOORE, PE ROADWAY DESIGN PROJECT ENGINEER

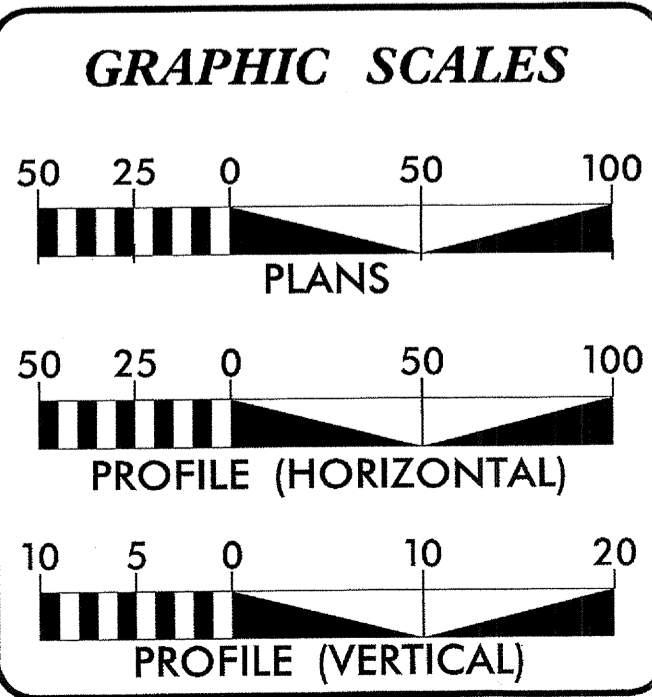

DESIGN DATA

ADT 2012 =	9,652
ADT 2032 =	13,172
DHV =	10 %
D =	60 %
T =	3% *
V =	50 MPH
* (TTST 1% + DUAL 2%)	
Functional Class.:	Urban Collector
SUBREGIONAL TIER	

PROJECT LENGTH

LENGTH ROADWAY TIP PROJECT B-4656 =	0.313 MILES
TOTAL LENGTH TIP PROJECT B-4656 =	0.313 MILES

Prepared in the Office of:
THE LOUIS BERGER GROUP, Inc.
1001 Wade Avenue, Suite 400
Raleigh, North Carolina 27605
For North Carolina Department of Transportation

2012 STANDARD SPECIFICATIONS

RIGHT OF WAY DATE:
July 15, 2011

LETTING DATE:
October 16, 2012

DEAN HATFIELD, PE
PROJECT ENGINEER

WILLIAM TILLITT, PE
PROJECT DESIGN ENGINEER

HYDRAULICS ENGINEER

Dean Hatfield
SIGNATURE: 8/14/12

ROADWAY DESIGN ENGINEER

Dean Hatfield
SIGNATURE: 8/14/12

SEAL 16003
NORTH CAROLINA PROFESSIONAL ENGINEER
DEAN D. HATFIELD

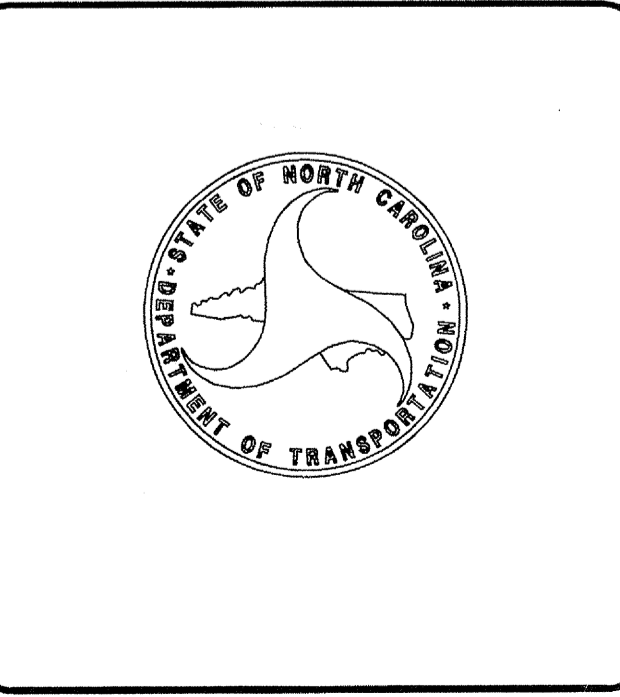

GENERAL NOTES: 2012 SPECIFICATIONS

EFFECTIVE: 01-17-12
REVISED: 11/01/11

GRADING AND SURFACING OR RESURFACING AND WIDENING:

THE GRADE LINES SHOWN DENOTE THE FINISHED ELEVATION OF THE PROPOSED SURFACING AT GRADE POINTS SHOWN ON THE TYPICAL SECTIONS. WHERE NO GRADE LINES ARE SHOWN, THE PROFILES SHOWN DENOTE THE TOP ELEVATION OF THE EXISTING PAVEMENT ALONG THE CENTER LINE OF SURVEY ON WHICH THE PROPOSED RESURFACING WILL BE PLACED. GRADE LINES MAY BE ADJUSTED BY THE ENGINEER IN ORDER TO SECURE A PROPER TIE-IN.

CLEARING:

CLEARING ON THIS PROJECT SHALL BE PERFORMED TO THE LIMITS ESTABLISHED BY METHOD III.

SUPERELEVATION:

ALL CURVES ON THIS PROJECT SHALL BE SUPERELEVATED IN ACCORDANCE WITH STD. NO. 225.04 USING THE RATE OF SUPERELEVATION AND RUNOFF SHOWN ON THE PLANS. SUPERELEVATION IS TO BE REVOLVED ABOUT THE GRADE POINTS SHOWN ON THE TYPICAL SECTIONS.

SHOULDER CONSTRUCTION:

ASPHALT, EARTH, AND CONCRETE SHOULDER CONSTRUCTION ON THE HIGH SIDE OF SUPERELEVATED CURVES SHALL BE IN ACCORDANCE WITH STD. NO. 560.01.

SIDE ROADS:

THE CONTRACTOR WILL BE REQUIRED TO DO ALL NECESSARY WORK TO PROVIDE SUITABLE CONNECTIONS WITH ALL ROADS, STREETS, AND DRIVES ENTERING THIS PROJECT. THIS WORK WILL BE PAID FOR AT THE CONTRACT UNIT PRICE FOR THE PARTICULAR ITEMS INVOLVED.

DRIVEWAYS:

DRIVEWAYS SHALL BE CONSTRUCTED IN ACCORDANCE WITH STD. 848.03 AT LOCATIONS SHOWN ON PLANS OR AS DIRECTED BY THE ENGINEER.

STREET TURNOUT:

STREET RETURNS SHALL BE CONSTRUCTED IN ACCORDANCE WITH STD. NO. 848.04 USING THE RADIUS NOTED ON PLANS.

TEMPORARY SHORING:

SHORING REQUIRED FOR THE MAINTENANCE OF TRAFFIC WILL BE PAID FOR AS "EXTRA WORK" IN ACCORDANCE WITH SECTION 104-7.

SUBSURFACE PLANS:

NO SUBSURFACE PLANS ARE AVAILABLE ON THIS PROJECT. THE CONTRACTOR SHOULD MAKE HIS OWN INVESTIGATION AS TO THE SUBSURFACE CONDITIONS.

UTILITIES:

UTILITY OWNERS ON THIS PROJECT ARE PROGRESS ENERGY (POWER), AT&T (PHONE), TIME WARNER CABLE (CATV), PSNC ENERGY (GAS), CITY OF RALEIGH-SEWER AND CITY OF RALEIGH-WATER.

ANY RELOCATION OF EXISTING UTILITIES WILL BE ACCOMPLISHED BY OTHERS.

RIGHT-OF-WAY MARKERS:

ALL RIGHT-OF-WAY MARKERS ON THIS PROJECT SHALL BE PLACED BY CONTRACT.

CURB RAMPS

CURB RAMPS ARE SHOWN ON THE PLANS AT APPROXIMATE LOCATIONS. CONSTRUCT ALL CURB RAMPS IN ACCORDANCE WITH STD 848.05 AND/OR 848.06.

2012 ROADWAY ENGLISH STANDARD DRAWINGS

The following Roadway Standards as appear in "Roadway Standard Drawings" Highway Design Branch - N. C. Department of Transportation - Raleigh, N. C., Dated January, 2012 are applicable to this project and by reference hereby are considered a part of these plans:

STD.NO.	TITLE
DIVISION 2 - EARTHWORK	
200.03	Method of Clearing - Method III
225.02	Guide for Grading Subgrade - Secondary and Local
225.04	Method of Obtaining Superelevation - Two Lane Pavement
DIVISION 3 - PIPE CULVERTS	
300.01	Method of Pipe Installation
310.02	Parallel Pipe End Section - Precast Concrete Section for 15" to 24" Pipe
310.03	Cross Pipe End Section - Precast Concrete Section for 18" to 30" Pipe
310.04	Parallel Pipe End Section - Prefabricated Steel Section for 15" to 24" Pipe
310.05	Cross Pipe End Section - Prefabricated Steel Section for 18" to 30" Pipe
DIVISION 5 - SUBGRADE, BASES AND SHOULDERS	
560.01	Method of Shoulder Construction - High Side of Superelevated Curve - Method I
DIVISION 6 - ASPHALT BASES AND PAVEMENTS	
654.01	Pavement Repairs
DIVISION 8 - INCIDENTALS	
806.01	Concrete Right-of-Way Marker
806.02	Granite Right-of-Way Marker
840.00	Concrete Base Pad for Drainage Structures
840.01	Brick Catch Basin - 12" thru 54" Pipe
840.02	Concrete Catch Basin - 12" thru 54" Pipe
840.03	Frame, Grates and Hood - for Use on Standard Catch Basin
840.14	Concrete Drop Inlet - 12" thru 30" Pipe
840.15	Brick Drop Inlet - 12" thru 30" Pipe
840.16	Drop Inlet Frame and Grates - for use with Std. Dwg 840.14 and 840.15
840.25	Anchorage for Frames - Brick or Concrete or Precast
840.45	Precast Drainage Structure
840.54	Manhole Frame and Cover
840.66	Drainage Structure Steps
840.71	Concrete and Brick Pipe Plug
840.72	Pipe Collar
846.01	Concrete Curb, Gutter and Curb & Gutter
848.01	Concrete Sidewalk
848.03	Driveway Turnout - Drop Curb Type
848.04	Street Turnout
848.05	Curb Ramp - Proposed Curb & Gutter
848.06	Curb Ramp - Existing Curb & Gutter
852.01	Concrete Islands
852.06	Method for Placement of Drop Inlets in Concrete Islands
866.01	Chain Link Fence - 4', 5' and 6' High Fence
876.02	Guide for Rip Rap at Pipe Outlets
876.04	Drainage Ditches with Class 'B' Rip Rap

INDEX OF SHEETS

1	TITLE SHEET
1A	INDEX OF SHEETS, GENERAL NOTES, AND LIST OF STANDARD DRAWINGS
1B	CONVENTIONAL SYMBOLS
1C	SURVEY CONTROL
2 THRU 2B	PAVEMENT SCHEDULE, TYPICAL SECTIONS, AND WEDGING DETAILS
2C	CURB RAMPS DETAIL
2D	PEDESTRIAN SAFETY RAIL DETAIL
2E	DETAIL TO CONVERT EXISTING DROP INLET OR CATCH BASIN TO TRAFFIC BEARING JUNCTION BOX (MANHOLE OPTION)
2F	DETAIL FOR TEMPORARY CONTAINMENT OF PETROLEUM CONTAMINATED SOIL
3 (2 SHEETS)	SUMMARY OF QUANTITIES
3A THRU 3C	DRAINAGE SUMMARY
3D	EARTHWORK SUMMARY, PAVEMENT REMOVAL AND GUARDRAIL REMOVAL
3E	PARCEL INDEX SHEET
4 THRU 5	PLAN SHEETS
6 THRU 8	PROFILE SHEETS
TMP-1 THRU TMP-9	TRAFFIC MANAGEMENT PLANS
SD-1	SPECIAL SIGN DESIGN PLANS
PM-1 THRU PM-4	PAVEMENT MARKING PLANS
EC-1 THRU EC-7	EROSION CONTROL PLANS
RF-1	REFORESTATION PLAN
SIGN-1 THRU SIGN-6	SIGNING PLANS
SIG-1 THRU SIG-34	SIGNAL PLANS
UC-1 THRU UC-5	UTILITY CONSTRUCTION PLANS
UO-1 THRU UO-3	UTILITIES BY OTHERS PLANS
X-1	CROSS-SECTION INDEX
X-1A	CROSS-SECTION EARTHWORK SUMMARY
X-2 THRU X-40	CROSS-SECTIONS

8/28/2012 G:\OR Projects\OR050 - Hillsborough Street Bridge\Roadway\Proj\B4656-RD1_01A_IDE.dgn
10:47:11 AM REVISIONS











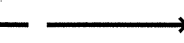

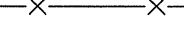
STATE OF NORTH CAROLINA
DIVISION OF HIGHWAYS

CONVENTIONAL PLAN SHEET SYMBOLS





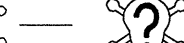



Note: Not to Scale

*S.U.E. = Subsurface Utility Engineering



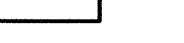
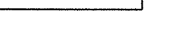
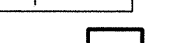





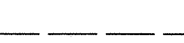

BOUNDARIES AND PROPERTY:

State Line	_____
County Line	_____
Township Line	_____
City Line	_____
Reservation Line	_____
Property Line	_____
Existing Iron Pin	_____ 
Property Corner	_____ 
Property Monument	_____ 
Parcel/Sequence Number	_____ 
Existing Fence Line	_____ 
Proposed Woven Wire Fence	_____ 
Proposed Chain Link Fence	_____ 
Proposed Barbed Wire Fence	_____ 
Existing Wetland Boundary	_____ 
Proposed Wetland Boundary	_____ 
Existing Endangered Animal Boundary	_____ 
Existing Endangered Plant Boundary	_____ 
Known Soil Contamination: Area or Site	_____ 
Potential Soil Contamination: Area or Site	_____ 



BUILDINGS AND OTHER CULTURE:

Gas Pump Vent or U/G Tank Cap	_____ 
Sign	_____ 
Well	_____ 
Small Mine	_____ 
Foundation	_____ 
Area Outline	_____ 
Cemetery	_____ 
Building	_____ 
School	_____ 
Church	_____ 
Dam	_____ 





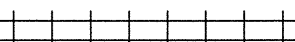

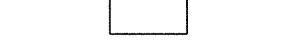
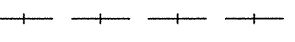
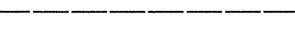





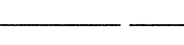
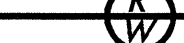

HYDROLOGY:

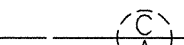
Stream or Body of Water	_____
Hydro, Pool or Reservoir	_____ 
Jurisdictional Stream	_____ 
Buffer Zone 1	_____ 
Buffer Zone 2	_____ 
Flow Arrow	_____ 
Disappearing Stream	_____ 
Spring	_____ 
Wetland	_____ 
Proposed Lateral, Tail, Head Ditch	_____ 
False Sump	_____ 

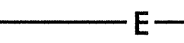
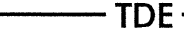





RAILROADS:

Standard Gauge	_____ 
RR Signal Milepost	_____ 
Switch	_____ 
RR Abandoned	_____ 
RR Dismantled	_____ 

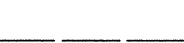
RIGHT OF WAY:

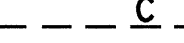
Baseline Control Point	_____ 
Existing Right of Way Marker	_____ 
Existing Right of Way Line	_____ 
Proposed Right of Way Line	_____ 
Proposed Right of Way Line with Iron Pin and Cap Marker	_____ 
Proposed Right of Way Line with Concrete or Granite RW Marker	_____ 
Proposed Control of Access Line with Concrete CA Marker	_____ 
Existing Control of Access	_____ 
Proposed Control of Access	_____ 
Existing Easement Line	_____ 
Proposed Temporary Construction Easement	_____ 
Proposed Temporary Drainage Easement	_____ 
Proposed Permanent Drainage Easement	_____ 
Proposed Permanent Drainage / Utility Easement	_____ 
Proposed Permanent Utility Easement	_____ 
Proposed Temporary Utility Easement	_____ 
Proposed Aerial Utility Easement	_____ 
Proposed Permanent Easement with Iron Pin and Cap Marker	_____ 

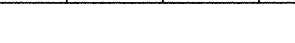

ROADS AND RELATED FEATURES:

Existing Edge of Pavement	_____
Existing Curb	_____
Proposed Slope Stakes Cut	_____ 
Proposed Slope Stakes Fill	_____ 
Proposed Curb Ramp	_____ 
Existing Metal Guardrail	_____ 
Proposed Guardrail	_____ 
Existing Cable Guiderail	_____ 
Proposed Cable Guiderail	_____ 

Equality Symbol _____ 



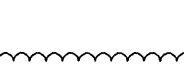
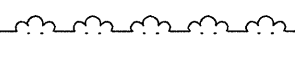

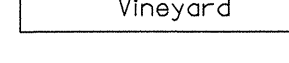

Pavement Removal _____ 

VEGETATION:

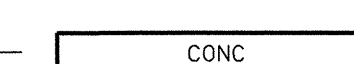
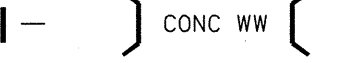
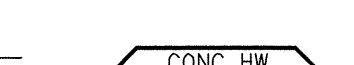
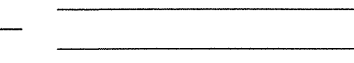

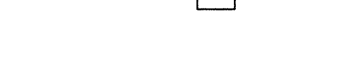





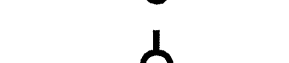

Single Tree	_____ 
Single Shrub	_____ 
Hedge	_____ 
Woods Line	_____ 

Orchard	_____ 
Vineyard	_____ 



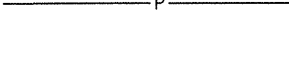



EXISTING STRUCTURES:

MAJOR:	
Bridge, Tunnel or Box Culvert	_____ 
Bridge Wing Wall, Head Wall and End Wall	_____ 
MINOR:	
Head and End Wall	_____ 
Pipe Culvert	_____ 
Footbridge	_____ 
Drainage Box: Catch Basin, DI or JB	_____ 
Paved Ditch Gutter	_____ 
Storm Sewer Manhole	_____ 
Storm Sewer	_____ 

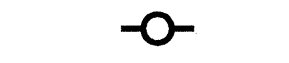

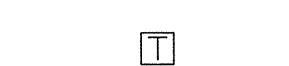

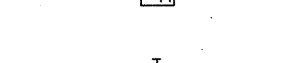
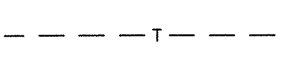
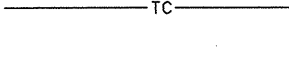
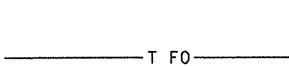
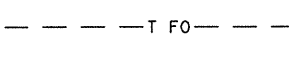

UTILITIES:

POWER:	
Existing Power Pole	_____ 
Proposed Power Pole	_____ 
Existing Joint Use Pole	_____ 
Proposed Joint Use Pole	_____ 
Power Manhole	_____ 
Power Line Tower	_____ 
Power Transformer	_____ 
U/G Power Cable Hand Hole	_____ 
H-Frame Pole	_____ 
Recorded U/G Power Line	_____ 
Designated U/G Power Line (S.U.E.*)	_____ 







TELEPHONE:

Existing Telephone Pole	_____ 
Proposed Telephone Pole	_____ 
Telephone Manhole	_____ 
Telephone Booth	_____ 
Telephone Pedestal	_____ 
Telephone Cell Tower	_____ 
U/G Telephone Cable Hand Hole	_____ 
Recorded U/G Telephone Cable	_____ 
Designated U/G Telephone Cable (S.U.E.*)	_____ 
Recorded U/G Telephone Conduit	_____ 
Designated U/G Telephone Conduit (S.U.E.*)	_____ 
Recorded U/G Fiber Optics Cable	_____ 
Designated U/G Fiber Optics Cable (S.U.E.*)	_____

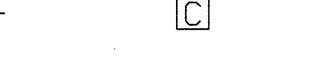

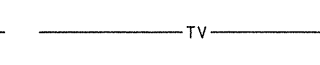
WATER:

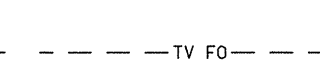
Water Manhole	_____ 
Water Meter	_____ 
Water Valve	_____ 
Water Hydrant	_____ 
Recorded U/G Water Line	_____ 
Designated U/G Water Line (S.U.E.*)	_____ 
Above Ground Water Line	_____ 



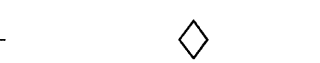
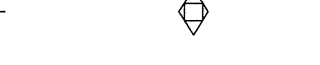
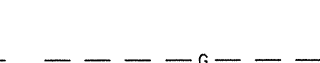
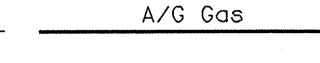

TV:

TV Satellite Dish	_____ 
TV Pedestal	_____ 
TV Tower	_____ 
U/G TV Cable Hand Hole	_____ 
Recorded U/G TV Cable	_____ 
Designated U/G TV Cable (S.U.E.*)	_____ 
Recorded U/G Fiber Optic Cable	_____ 
Designated U/G Fiber Optic Cable (S.U.E.*)	_____ 



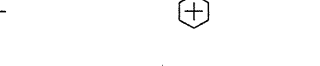

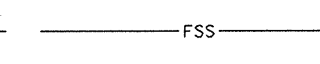
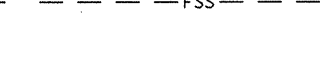

GAS:

Gas Valve	_____ 
Gas Meter	_____ 
Recorded U/G Gas Line	_____ 
Designated U/G Gas Line (S.U.E.*)	_____ 
Above Ground Gas Line	_____ 

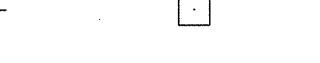
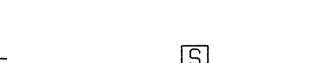
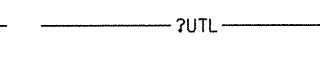
SANITARY SEWER:

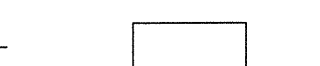
Sanitary Sewer Manhole	_____ 
Sanitary Sewer Cleanout	_____ 
U/G Sanitary Sewer Line	_____ 
Above Ground Sanitary Sewer	_____ 
Recorded SS Forced Main Line	_____ 
Designated SS Forced Main Line (S.U.E.*)	_____ 

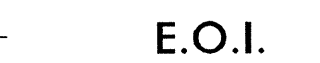
MISCELLANEOUS:

Utility Pole	_____ 
Utility Pole with Base	_____ 
Utility Located Object	_____ 
Utility Traffic Signal Box	_____ 
Utility Unknown U/G Line	_____ 
U/G Tank; Water, Gas, Oil	_____ 
Underground Storage Tank, Approx. Loc.	_____ 
A/G Tank; Water, Gas, Oil	_____ 
Geoenvironmental Boring	_____ 
U/G Test Hole (S.U.E.*)	_____ 
Abandoned According to Utility Records	_____ 
End of Information	_____

B-4656

SURVEY CONTROL SHEET B-4656

WAKE COUNTY

**LOCATION: REPLACE BRIDGE No. 492 OVER SR 1012 (WESTERN BLVD.)
ON SR 1011 (HILLSBOROUGH ST.) WITH AT-GRADE INTERSECTION**

PROJECT REFERENCE NO.	SHEET NO.
B-4656	1C
Location and Surveys	

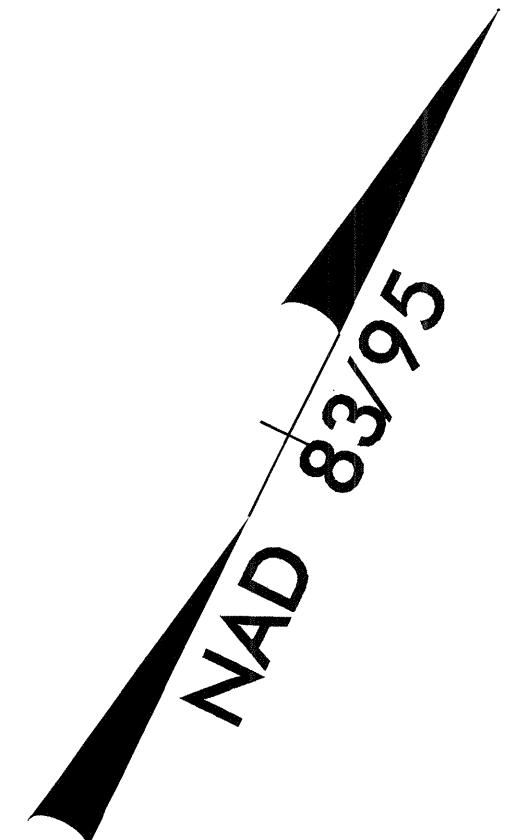

BENCHMARK DATA:

 BM1 ELEVATION = 476.30
 N 741219 E 2083320
 RR SPIKE IN 30" WILLOW OAK
 L2 STATION 22+87.53 RIGHT

 BM2 ELEVATION = 469.17
 N 742321 E 2083771
 OUTSIDE PROJECT LIMITS
 RR SPIKE IN 24" PINE

BASELINE DATA:

BY POINT	DESC.	NORTH	EAST	ELEVATION	L1 STATION	OFFSET
GPS2	B4656-2	740761.2084	2082431.6765	475.92	11+70.32	61.43 RT
GPS1	B4656-1	740970.9420	2083137.3000	487.92	18+99.42	27.19 LT
201	BY-201	741180.5700	2083611.3670	462.00	24+17.74	32.35 LT
202	BY-202	741219.5540	2084040.6610	453.56	28+47.43	34.57 RT

BY1 POINT	DESC.	NORTH	EAST	ELEVATION	L2 STATION	OFFSET
301	BY1-301	741206.5780	2082516.0020	483.98	14+79.64	30.29 RT
302	BY1-302	741284.9640	2083040.3550	479.99	20+08.56	19.88 LT
303	BY1-303	741292.9630	2083424.4200	468.90	23+92.70	17.93 LT
A310	NOT SET	741289.2979	2083455.1873	UNKNOWN	24+23.36	13.47 LT
A202	BY-202	741219.5540	2084040.6610	453.56	30+06.83	71.41 RT

BL POINT	DESC.	NORTH	EAST	ELEVATION	Y1 STATION	OFFSET
GPS2	B4656-2	740761.2084	2082431.6765	475.92	OUTSIDE PROJECT LIMITS	
GPS1	B4656-1	740970.9420	2083137.3000	487.92	OUTSIDE PROJECT LIMITS	
310	NO POINT SET	741289.2979	2083455.1873	UNKNOWN	10+37.95	203.87 LT
101	BL-101	741368.3910	2083534.1640	484.00	11+14.98	122.87 LT
102	BL-102	741778.0340	2083699.0740	466.99	15+28.38	27.09 RT
103	BL-103	742132.3240	2083781.6370	456.11	18+93.33	20.86 RT
104	BL-104	742582.6880	2083899.3740	478.48	OUTSIDE PROJECT LIMITS	

DWY1 POINT	DESC.	NORTH	EAST	ELEVATION	L1 STATION	OFFSET
303	BY1-303	741292.9630	2083424.4200	468.90	22+90.44	209.49 LT
401	BY2-401	741453.8490	2083395.8090	475.40	23+27.76	368.58 LT

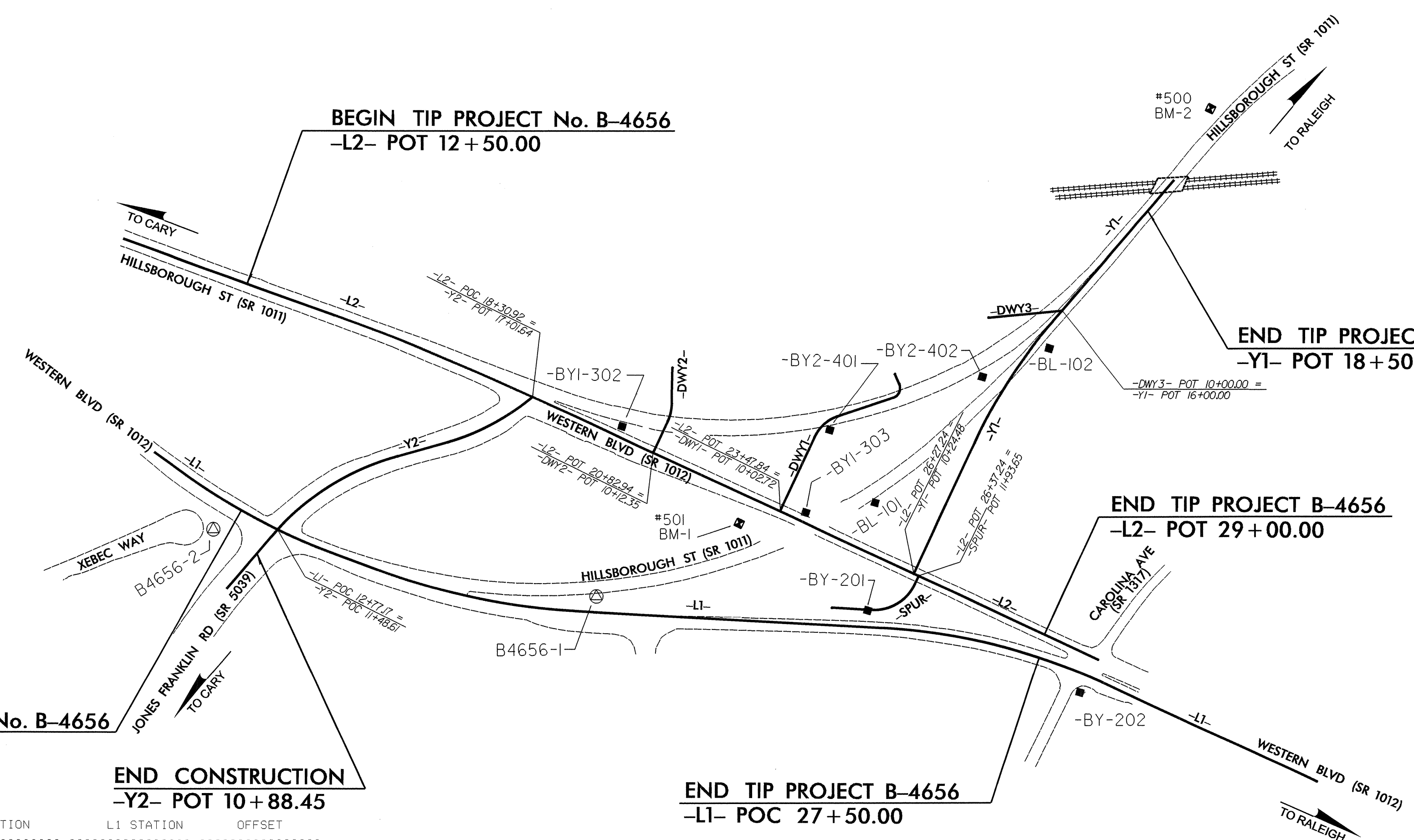

DWY1			
TYPE	STATION	NORTH	EAST
POT	10+00.00	741273.8742	2083380.0350
PC	11+54.71	741428.5342	2083376.0274
PT	12+14.79	741482.9635	2083397.4284
PC	13+26.66	741562.8748	2083475.7178
PT	13+59.73	741592.2637	2083474.2014
POT	13+79.73	741605.0336	2083458.8089

DWY2			
TYPE	STATION	NORTH	EAST
POT	10+12.35	741267.0153	2083115.2294
PC	10+77.41	741332.0517	2083113.5441
PT	11+12.82	741366.2453	2083105.3865
POT	11+81.56	741428.3707	2083075.9508

DWY3			
TYPE	STATION	NORTH	EAST
POT	10+00.00	741853.1627	2083689.1833
POT	11+40.00	741779.2405	2083570.2904

L1			
TYPE	STATION	NORTH	EAST
POT	10+00.00	740846.3249	2082268.0907
PC	10+72.86	740834.3849	2082339.9608
PT	13+91.78	740825.3769	2082657.7727
PC	14+81.78	740835.0734	2082747.2428
PT	18+63.76	740931.8698	2083115.2982
PC	24+48.93	741163.1806	2083652.8068
PT	28+82.04	741255.4852	2084073.2987
POT	33+27.05	741266.9617	2084518.1573

L2			
TYPE	STATION	NORTH	EAST
POT	10+00.00	741182.5942	2082038.3121
PC	14+26.75	741230.9917	2082460.3117
PT	18+61.10	741261.2660	2082893.4627
POT	30+11.41	741291.0631	2084043.3862

SPUR			
TYPE	STATION	NORTH	EAST
POT	10+00.00	741154.3873	2083548.8905
PC	10+75.67	741184.3005	2083518.4013
PT	11+76.85	741264.5796	2083669.7731
POT	11+93.65	741281.3707	2083669.3360

Y1			
TYPE	STATION	NORTH	EAST
POT	10+24.48	741281.1088	2083659.3414
PC	12+98.92	741555.4565	2083652.2324
PT	15+73.65	741827.6272	2083682.6949
POT	19+26.44	742169.5531	2083769.5758

Y2			
TYPE	STATION	NORTH	EAST
POT	10+00.00	740674.6061	2082506.7774
PC	11+30.42	740801.0775	2082538.6395
PT	14+18.18	741044.2945	2082684.5708
PC	15+16.91	741110.6318	2082757.6988
POC	17+01.64	741260.3909	2082863.2929

ROW MARKER BRIDGE SPIKE				
ALIGN	STATION	OFFSET	NORTH	EAST
L2	26+99.49	-48.06	741331.0257	2083730.3310

ROW MARKER BRIDGE SPIKE				
ALIGN	STATION	OFFSET	NORTH	EAST
L2	11+00.00	50.00	741357.8987	2083707.3684
Y1	12+98.92	50.00	741556.7517	2083702.2157
Y1	14+92.71	50.00	741740.0970	2083715.2526

PERMANENT EASEMENT - E REBAR AND CAP				
ALIGN	STATION	OFFSET	NORTH	EAST
L1	13+94.59	-64.50	740889.8072	2082653.6122
L1	15+78.00	-68.25	740916.1345	2082829.9988

PERMANENT EASEMENT - E REBAR AND CAP				
ALIGN	STATION	OFFSET	NORTH	EAST
Y2	12+80.00	52.66	740910.7292	2082641.4198

NOTES:

- THE CONTROL DATA FOR THIS PROJECT CAN BE FOUND ELECTRONICALLY BY SELECTING PROJECT CONTROL DATA AT:
[HTTP://WWW.NCDOT.ORG/DOH/PRECONSTRUCT/HIGHWAY/LOCATION/PROJECT/](http://www.ncdot.org/doh/preconstruct/highway/location/project/)
 THE FILES TO BE FOUND ARE AS FOLLOWS:
 B4656_LS_CONTROL_110325.TXT
 SITE CALIBRATION INFORMATION HAS NOT BEEN PROVIDED FOR THIS PROJECT. IF FURTHER INFORMATION IS NEEDED, PLEASE CONTACT THE LOCATION AND SURVEYS UNIT.
- INDICATES GEODETIC CONTROL MONUMENTS USED OR SET FOR HORIZONTAL PROJECT CONTROL BY THE NCDOT LOCATION AND SURVEYS UNIT.
 PROJECT CONTROL ESTABLISHED USING GLOBAL POSITIONING SYSTEM.
 NETWORK ESTABLISHED FROM EXISTING HARN POSITIONING
 SEE GPS CALIBRATION SHEET FOR HORIZONTAL AND VERTICAL COORDINATE VALUES.

DATUM DESCRIPTION

THE LOCALIZED COORDINATE SYSTEM DEVELOPED FOR THIS PROJECT IS BASED ON THE STATE PLANE COORDINATES ESTABLISHED BY NCDOT FOR MONUMENT "B4656-1"
 WITH NAD 1983/95 STATE PLANE GRID COORDINATES OF
 NORTHING: 740,970.9426(ft) EASTING: 2,083,137.3002(ft)
 THE AVERAGE COMBINED GRID FACTOR USED ON THIS PROJECT (GROUND TO GRID) IS: 0.99989795
 THE N.C. LAMBERT GRID BEARING AND LOCALIZED HORIZONTAL GROUND DISTANCE FROM "B4656-1" TO -L1- STATION 12+00.00 IS
 S 77°21'18.1" W 687.71'
 ALL LINEAR DIMENSIONS ARE LOCALIZED HORIZONTAL DISTANCES
 VERTICAL DATUM USED IS NAVD 88

NOTE: DRAWING NOT TO SCALE

PAVEMENT SCHEDULE

ITEM	DESCRIPTION
(C1)	Prop. Approx 2.0" Asphalt Concrete Surface Course, Type SF9.5A, at an Average Rate of 110 lbs. Per sq. yard in each of two layers.
(C2)	Prop. Approx 1.5" Asphalt Concrete Surface Course, Type S9.5B, at an Average Rate of 168 lbs. Per sq. yard.
(C3)	Prop. Approx 3.0" Asphalt Concrete Surface Course, Type S9.5B, at an Average Rate of 168 lbs. Per sq. yard in each of two layers.
(C4)	Prop. Var. Depth Asphalt Concrete Surface Course, Type S9.5B, at an Average Rate of 112 lbs. Per sq. yard Per 1" Depth, to be placed in layers not less than 1.5" or greater than 2" in depth.
(D1)	Prop. Approx 4.0" Asphalt Concrete Intermediate Course, Type I19.0B, at an Average Rate of 456 lbs. Per sq. yard.
(D2)	Prop. Var. Depth Asphalt Concrete Intermediate Course, Type I19.0B, at an Average Rate of 114 lbs. Per sq. yard Per 1" Depth, to be placed in layers not less than 2.5" or greater than 4.0" in depth.
(E1)	Prop. Approx 4.0" Asphalt Concrete Base Course, Type B25.0B, at an Average Rate of 456.0 lbs. Per sq. yard.
(E2)	Prop. Approx 5.5" Asphalt Concrete Base Course, Type B25.0B, at an Average Rate of 627.0 lbs. Per sq. yard.
(E3)	Variable Depth Asphalt Concrete Base Course, Type B25.0B at an Average Rate of 114 lbs. Per sq. yard per 1" depth to be placed in layers not less than 3" or greater than 5.5" in depth.
(J)	Prop. Approx 6.0" Aggregate Base Course
(P)	Prime Coat at the Rate of 0.35 GAL/SY
(R1)	2'-6" Curb & Gutter
(R2)	5" Monolithic Island (Keyed In)
(S)	4.0" Concrete Sidewalk
(T)	Earth Material
(U)	Existing Pavement
(W)	Var. Depth Asphalt Pavement (See Wedging Detail This Sheet)

NOTE: PAVEMENT EDGE SLOPES ARE 1:1 UNLESS OTHERWISE INDICATED.

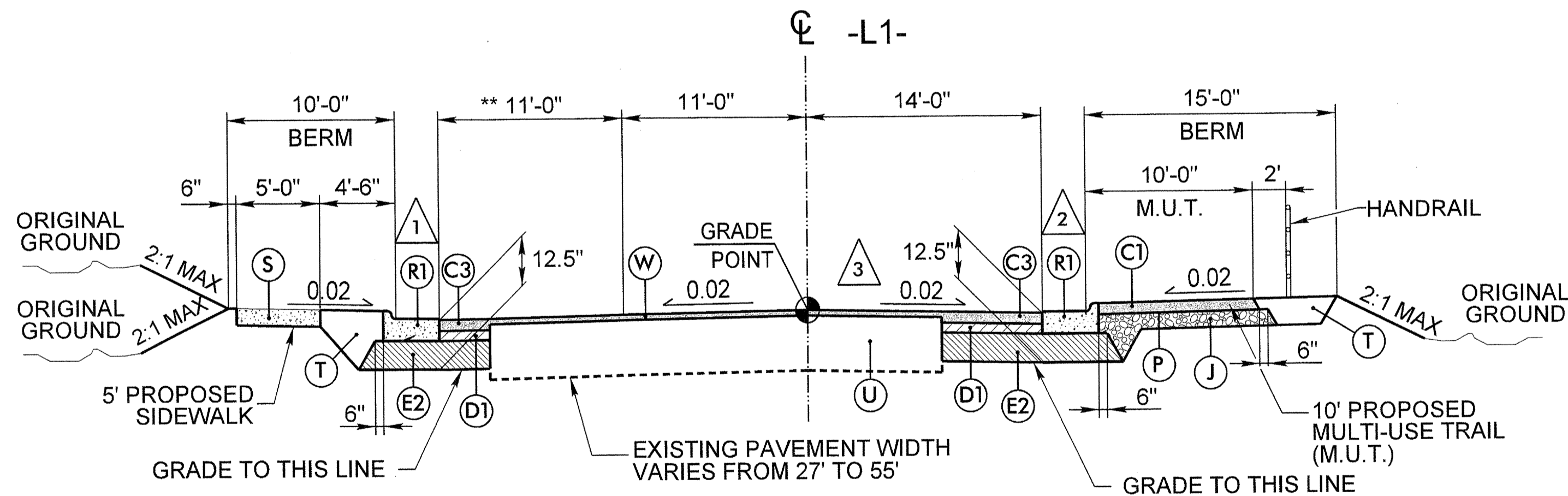

TYPICAL SECTION No. 1

(WESTERN BOULEVARD)
-L1- STA. 13+50 TO STA. 23+00

- 1 CURB & GUTTER w/SIDEWALK FROM:
-L1- 12+00.00 TO -L1- 23+50.00 LT
- 2 CURB & GUTTER w/M.U.T. FROM:
-L1- 13+00.00 TO -L1- 19+75.00 RT
- 3 MATCH EXIST. SUPERELEVATIONS AT -L1- 23+00.00

** SEE PLAN SHEETS FOR ACTUAL LANE WIDTHS

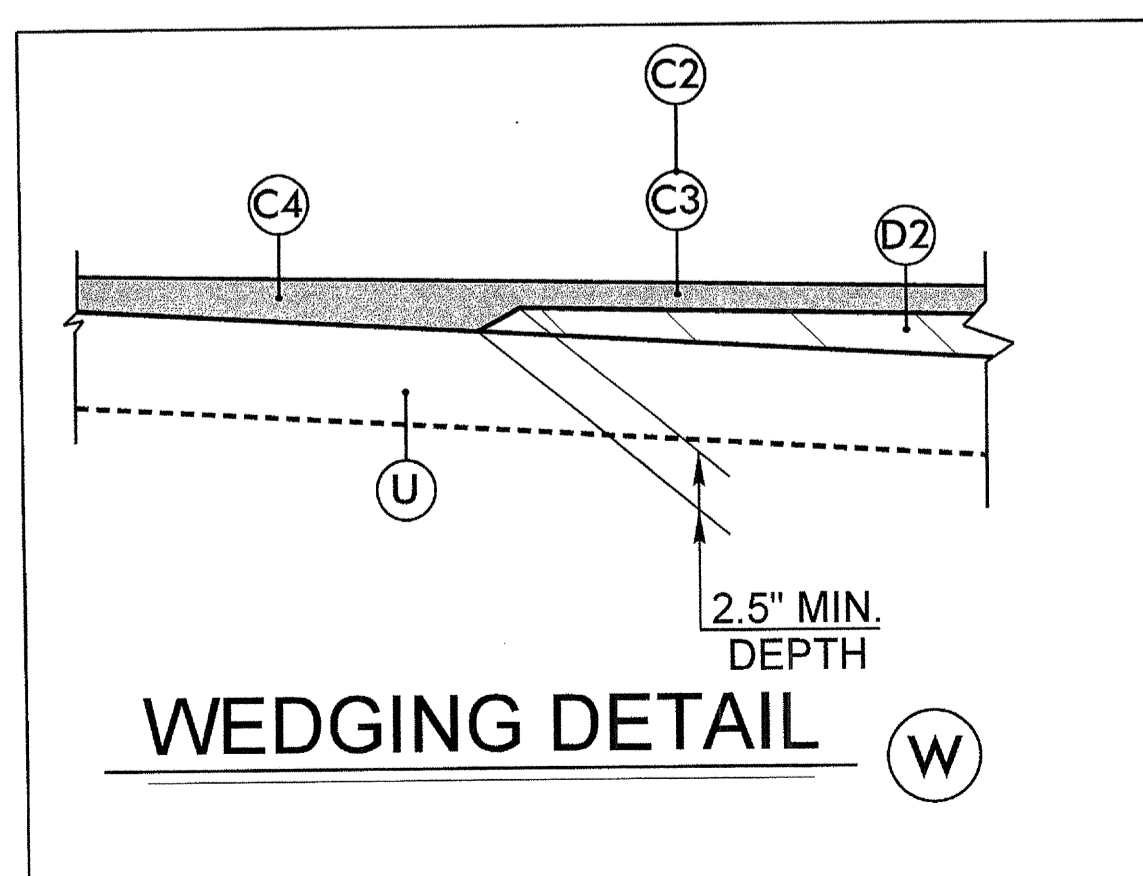

WEDGING DETAIL

N.T.S.

PROJECT REFERENCE NO. B-4656	SHEET NO. 2
RW SHEET NO.	
ROADWAY DESIGN ENGINEER SEAL 14004 ANDREW D. HAIFIELD	PAVEMENT ENGINEER SEAL 22896 CLAYTON S. MORRISON

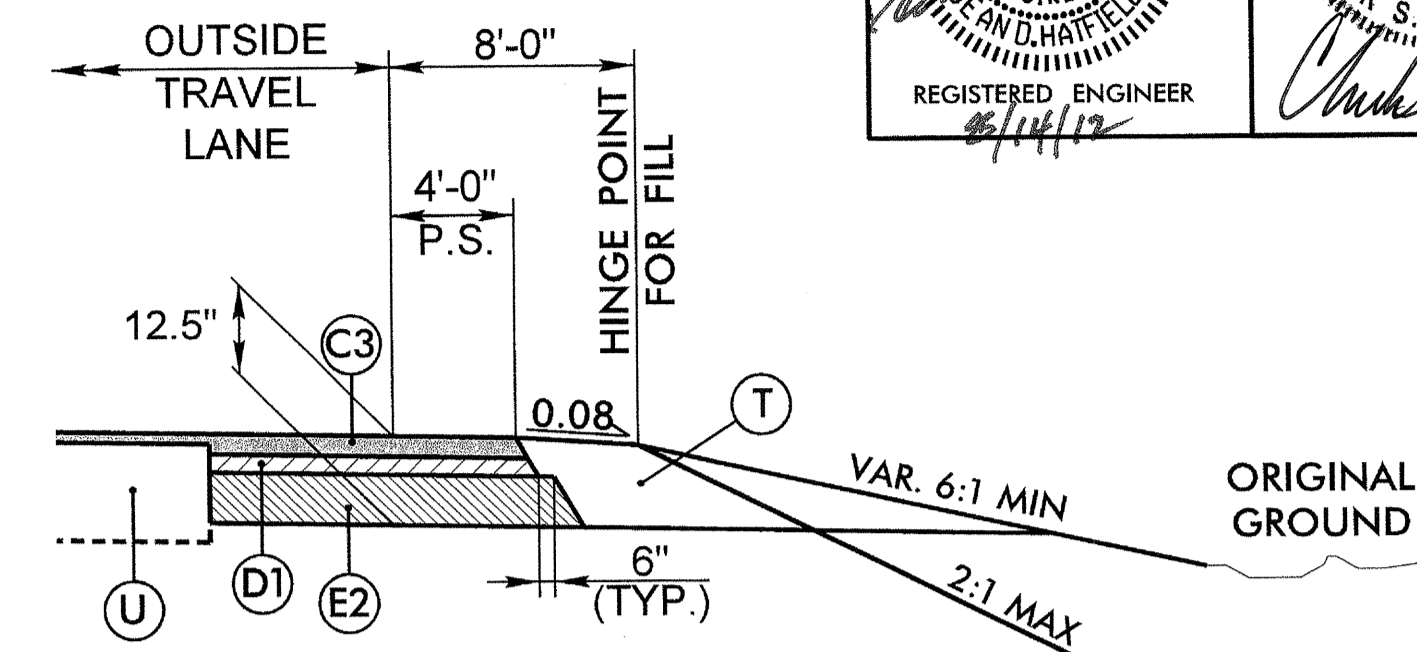

RIGHT PAVED SHOULDER DETAIL

(USE IN CONJUNCTION WITH TYPICAL SECTION No. 1)
-L1- STA. 20+50 TO STA. 27+50 RT

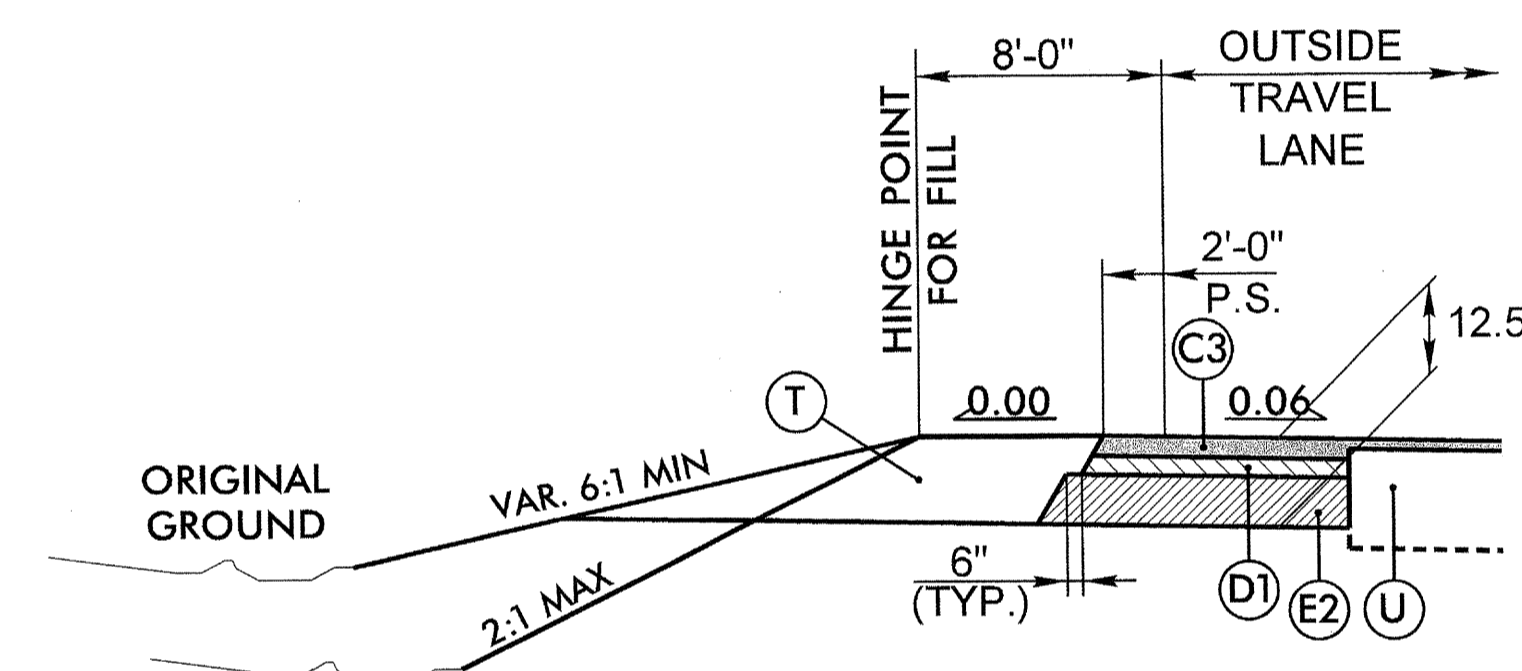

LEFT PAVED SHOULDER DETAIL

(USE IN CONJUNCTION WITH TYPICAL SECTION No. 1)
-L1- STA. 25+00 TO STA. 27+50 LT

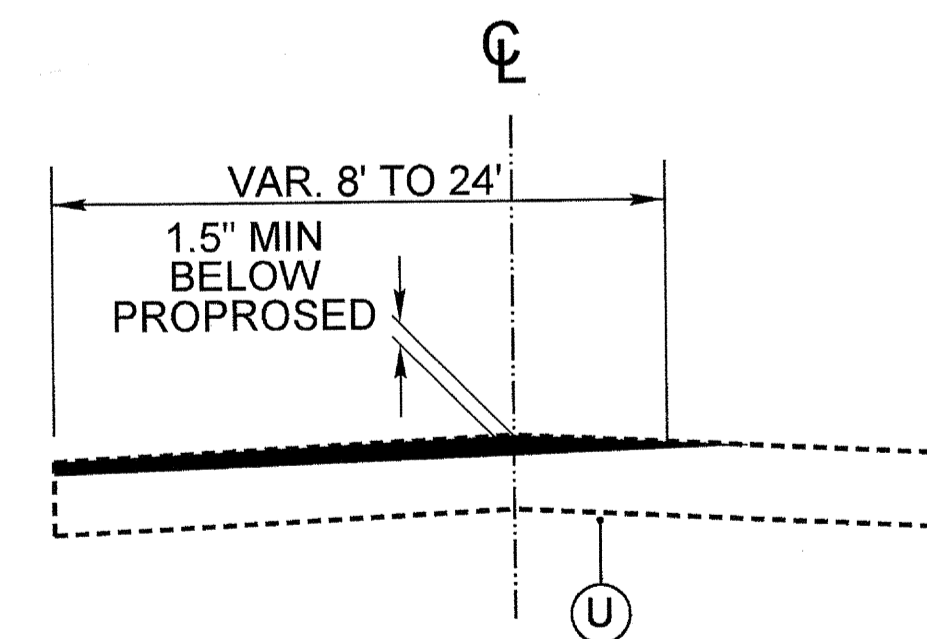

INCIDENTAL MILLING DETAIL

- L1- 12+00 TO 13+50
- L1- 23+00 TO 27+50
- L2- 12+50 TO 13+00
- L2- 28+25 TO 29+00
- Y1- 18+00 TO 18+50
- Y2- 10+83 TO 11+63
- Y2- 16+25 TO 17+02

8/15/2012 G:\UR\Projects\DR1050 - Hillsborough Street Bridge Roadway\Proj\B4656_R0Y_02_TYP.dgn 11:09:58 AM

REVISIONS

N.T.S.

PROJECT REFERENCE NO. B-4656	SHEET NO. 2A
RW SHEET NO.	
ROADWAY DESIGN ENGINEER SEAL 16000 ANDREW D. HARRIS REGISTERED ENGINEER 8/14/12	PAVEMENT ENGINEER SEAL 22898 CLARK S. MORRISON REGISTERED ENGINEER 8/29/12

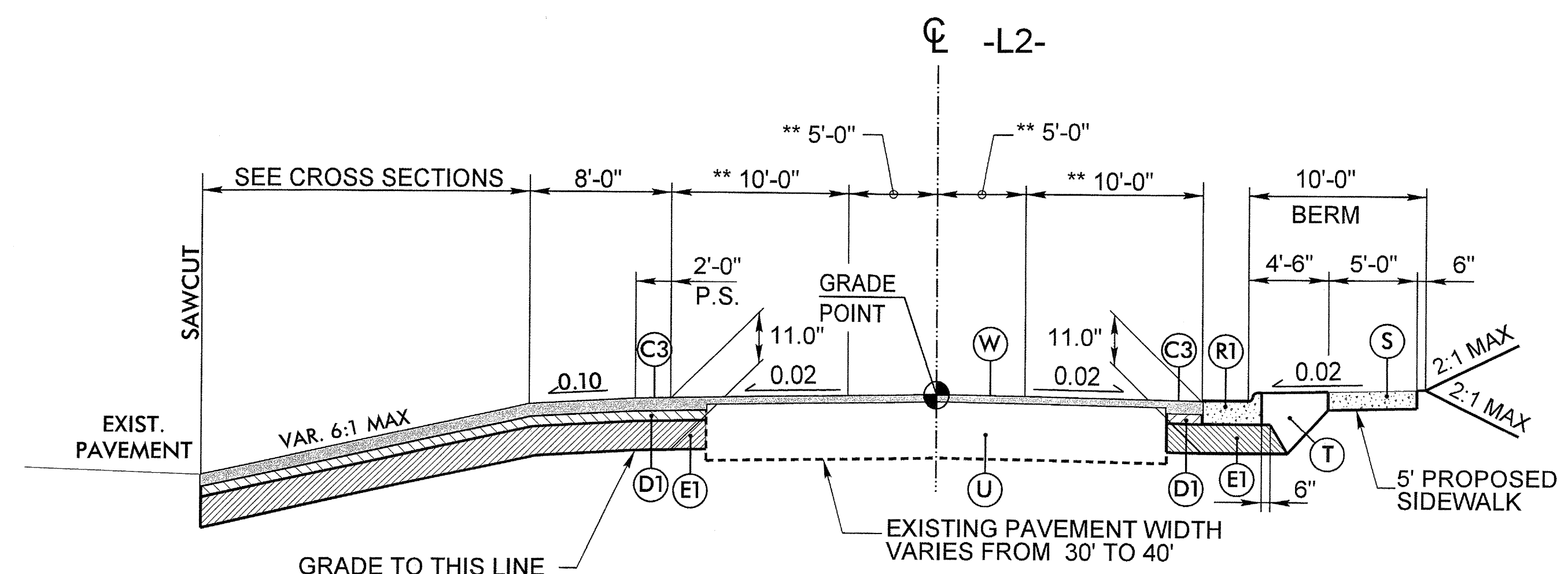

TYPICAL SECTION No. 2
(HILLSBOROUGH STREET)
-L2- STA. 12+50 TO STA. 18+65

** SEE PLAN SHEETS FOR ACTUAL LANE WIDTHS

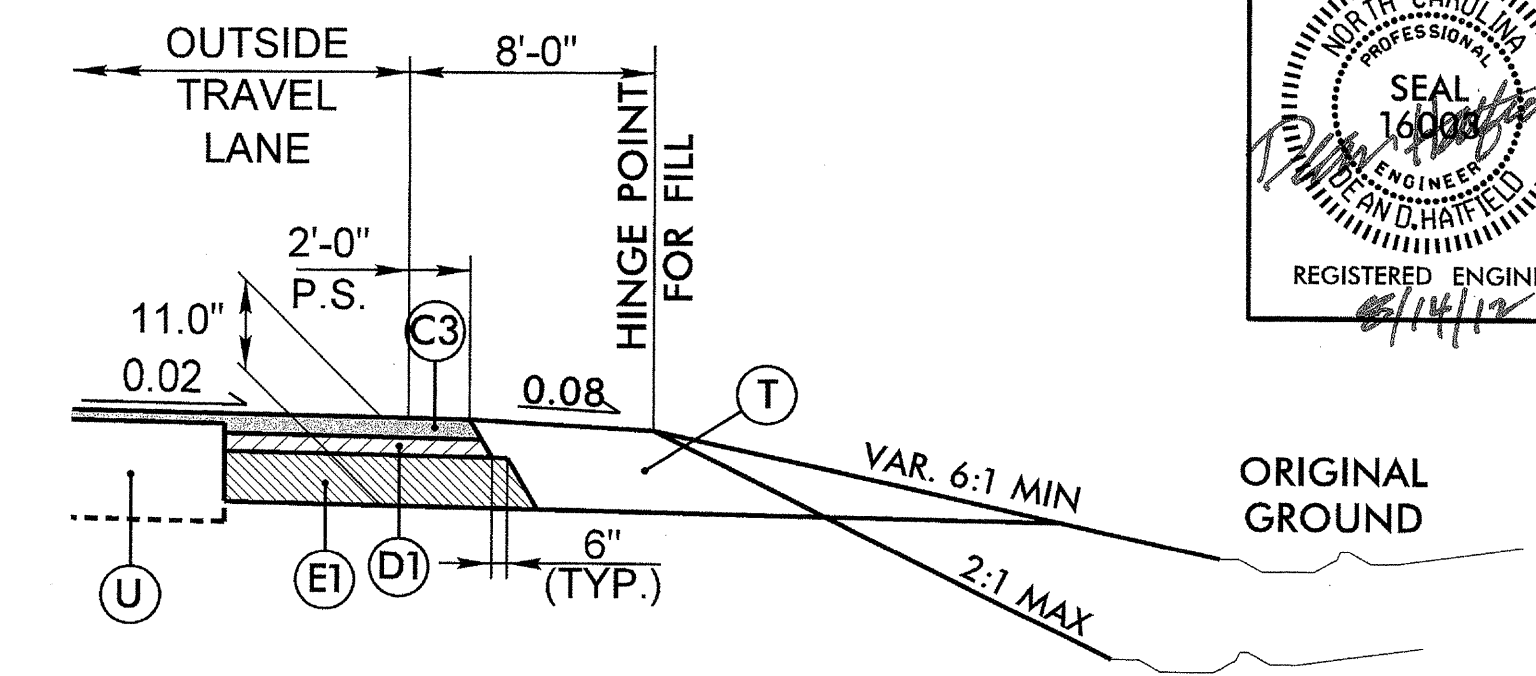

RIGHT PAVED SHOULDER DETAIL

(USE IN CONJUNCTION WITH TYPICAL SECTION No. 3)
-L2- STA. 27+00 TO STA. 29+00 RT

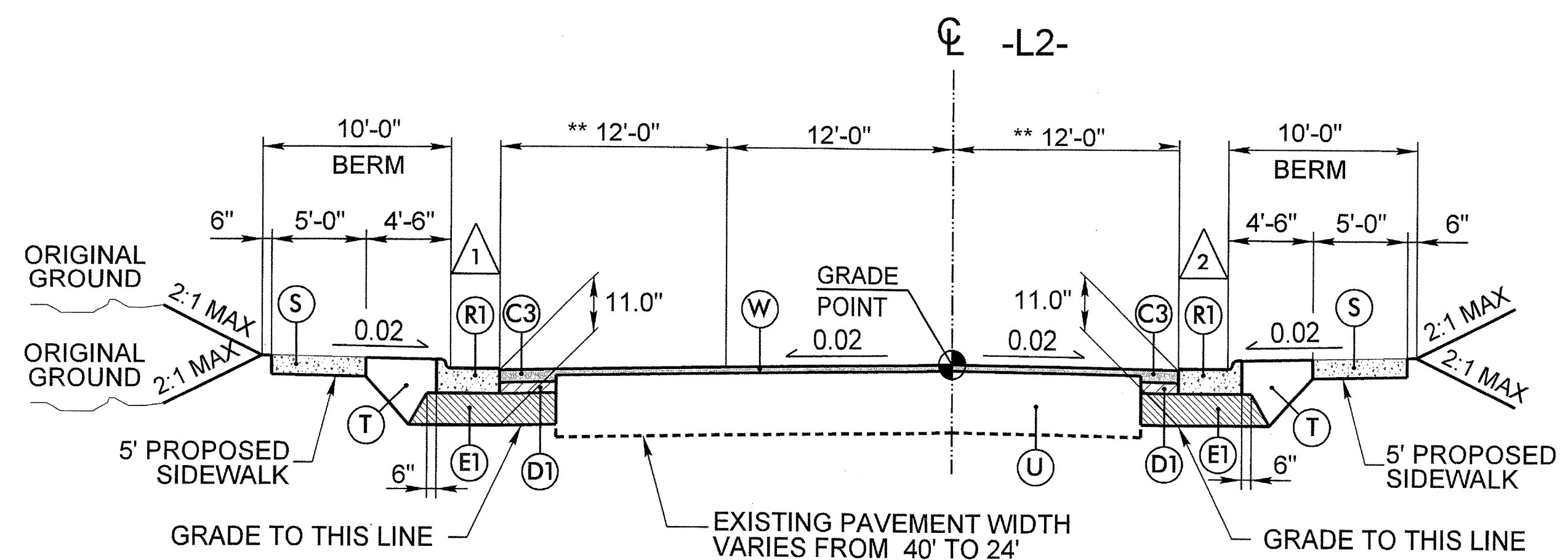

TYPICAL SECTION No. 3
(HILLSBOROUGH STREET)
-L2- STA. 18+65 TO STA. 29+00

- 1 CURB & GUTTER w/SIDEWALK FROM:
-L2- 18+65.00 TO -L2- 27+20.00 LT
- 2 CURB & GUTTER w/SIDEWALK FROM:
-L2- 18+65.00 TO -L2- 26+00.00 RT

** SEE PLAN SHEETS FOR ACTUAL LANE WIDTHS

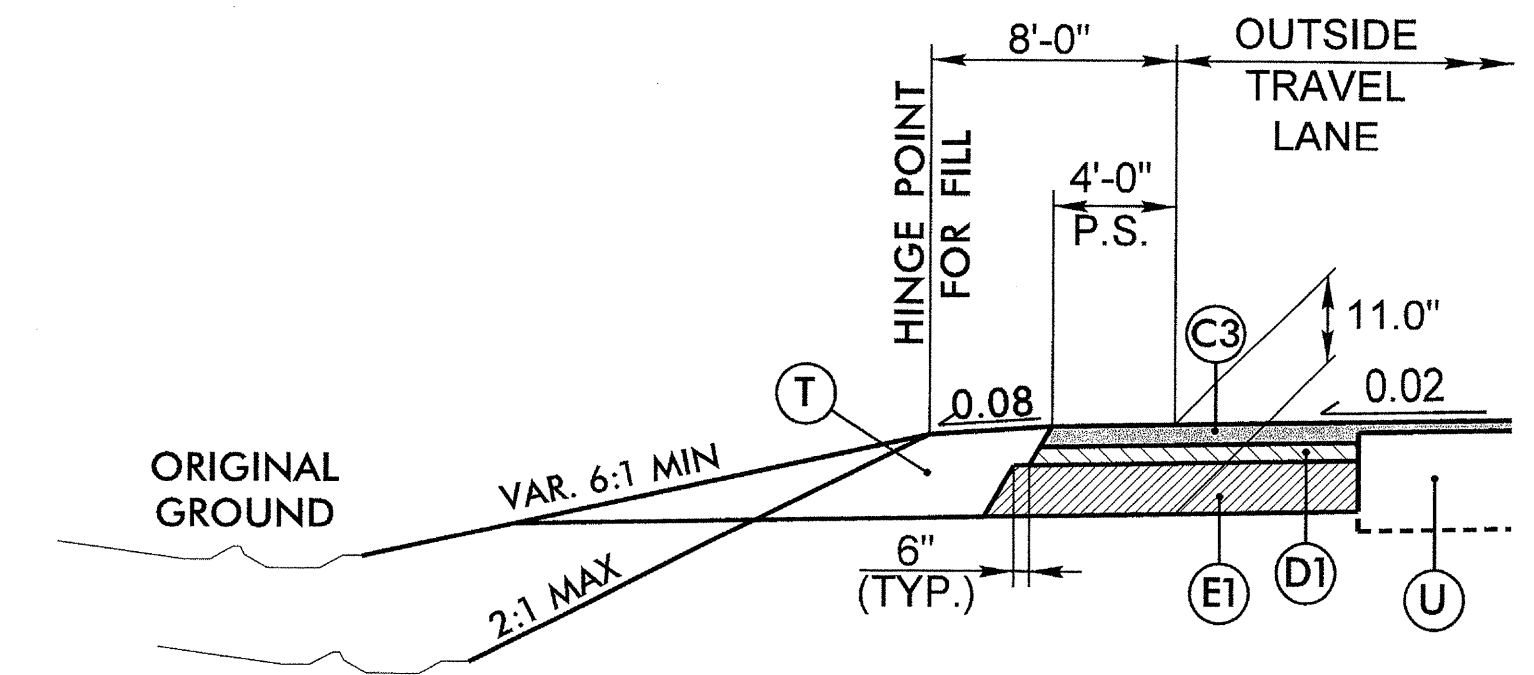

LEFT PAVED SHOULDER DETAIL

(USE IN CONJUNCTION WITH TYPICAL SECTION No. 3)
-L2- STA. 27+20 TO STA. 29+00 LT

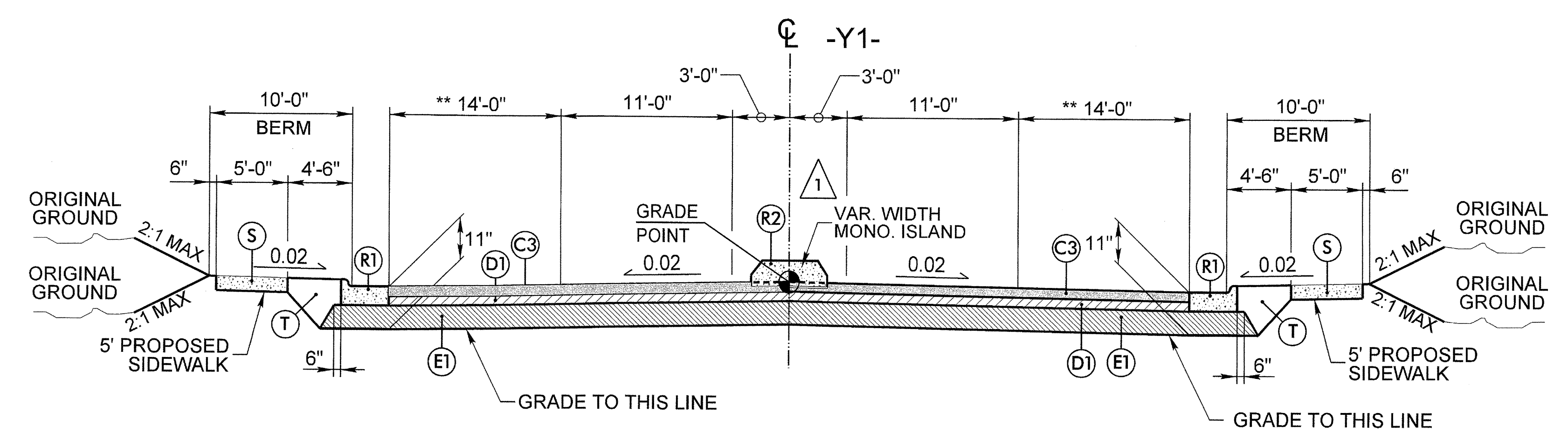

TYPICAL SECTION No. 4
(HILLSBOROUGH STREET EXT.)
-Y1- STA. 10+36.48 TO STA. 18+50

- 1 MONO. ISLAND FROM:
-Y1- 10+40.48 TO -Y1- 17+25.00

** SEE PLAN SHEETS FOR ACTUAL LANE WIDTHS

PAVEMENT SCHEDULE	
C1	2.0" Type SF9.5A
C2	1.5" Type S9.5B
C3	3.0" Type S9.5B
C4	Var. Depth Type S9.5B
D1	4.0" Type I19.0B
D2	Var. Depth Type I19.0B
E1	4.0" Type B25.0B
E2	5.5" Type B25.0B
E3	Var. Depth Type B25.0B
J	Prop. Approx 6.0" Aggregate Base Course
P	Prime Coat
R1	2'-6" Curb & Gutter
R2	5" Mono. Island
S	4.0" Concrete Sidewalk
T	Earth Material
U	Existing Pavement
W	Var. Depth Asphalt Pavement

NOTE: PAVEMENT EDGE SLOPES ARE 1:1 UNLESS OTHERWISE INDICATED.

THE LOUIS BERGER GROUP, Inc.
1001 Wade Avenue, Suite 400
Raleigh, North Carolina 27605

8/15/2012
 G:\DR Projects\010500 - Hillsborough Street Bridge\Roadway\Proj\B4656-RD\02A_TYP.dgn
 11:05:00 AM

REVISIONS

N.T.S.

PROJECT REFERENCE NO. B-4656	SHEET NO. 2B
RW SHEET NO.	
ROADWAY DESIGN ENGINEER SEAL 14003 ANDREW D. HATFIELD REGISTERED ENGINEER	PAVEMENT ENGINEER SEAL 22896 CLARK S. MORRISON REGISTERED ENGINEER

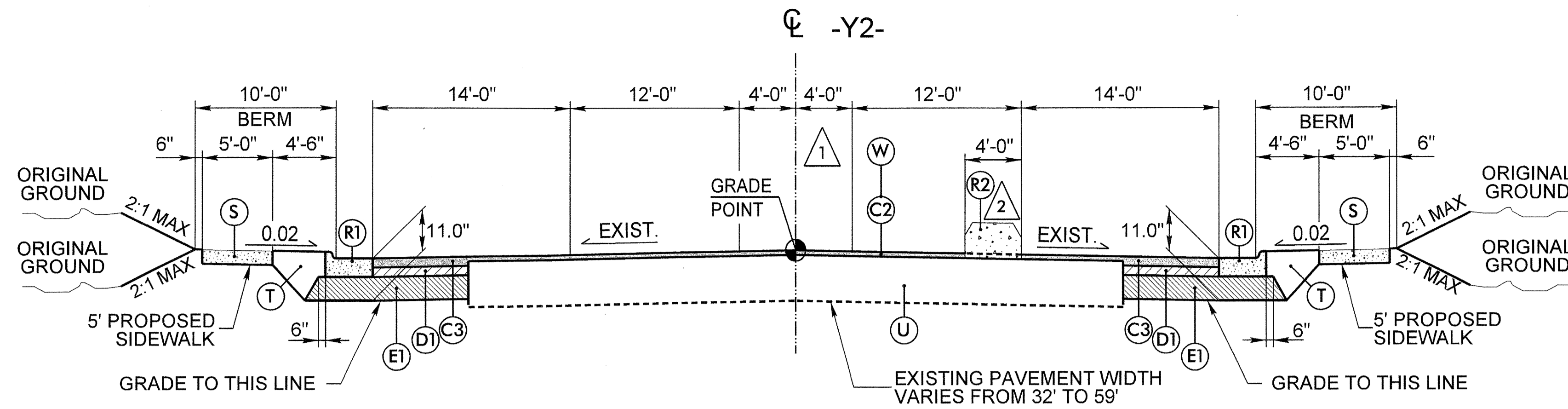

TYPICAL SECTION No. 5

(JONES FRANKLIN RD.)
-Y2- STA. 11+63.46 TO STA. 16+25

- 1 PAINTED ISLAND FROM:
-Y2- 13+20.00 TO -Y2- 16+25.00
- 2 MONO. ISLAND FROM:
-Y2- 12+43.75 TO -Y2- 13+20.00

** SEE PLAN SHEETS FOR ACTUAL LANE WIDTHS

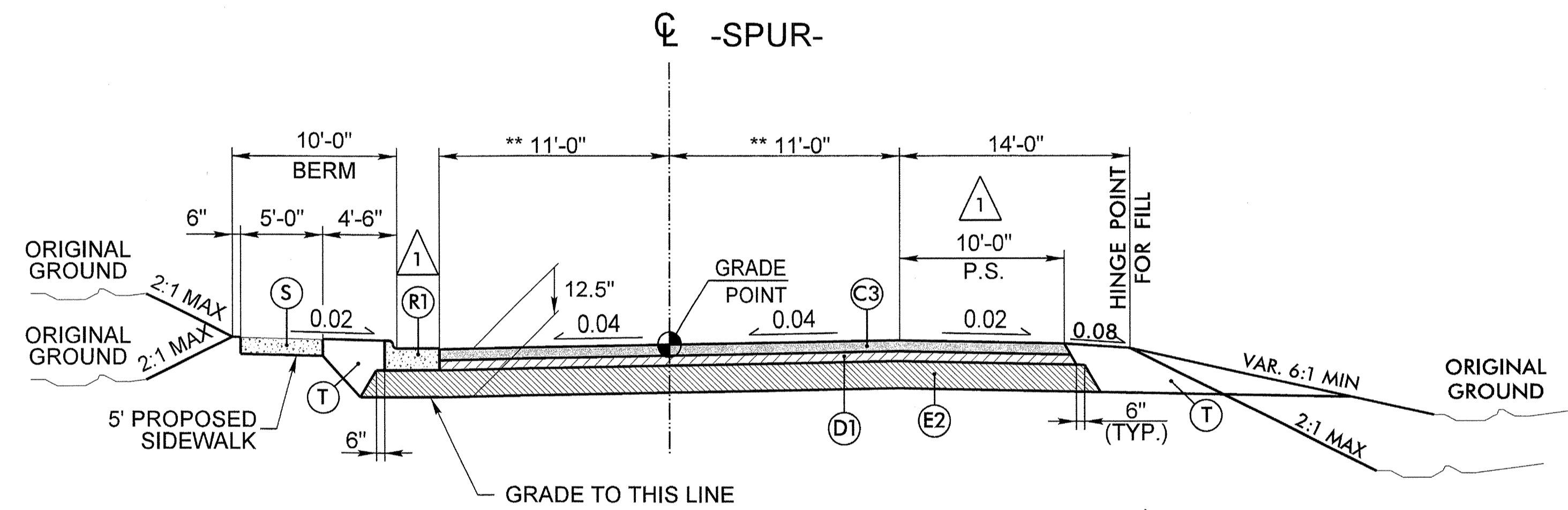

TYPICAL SECTION No. 6

-SPUR- STA. 10+00 TO STA. 11+81.65

- 1 PAVED SHOULDER FROM:
-SPUR- 11+27.20 TO -SPUR- 11+81.65

** SEE PLAN SHEETS FOR ACTUAL LANE WIDTHS

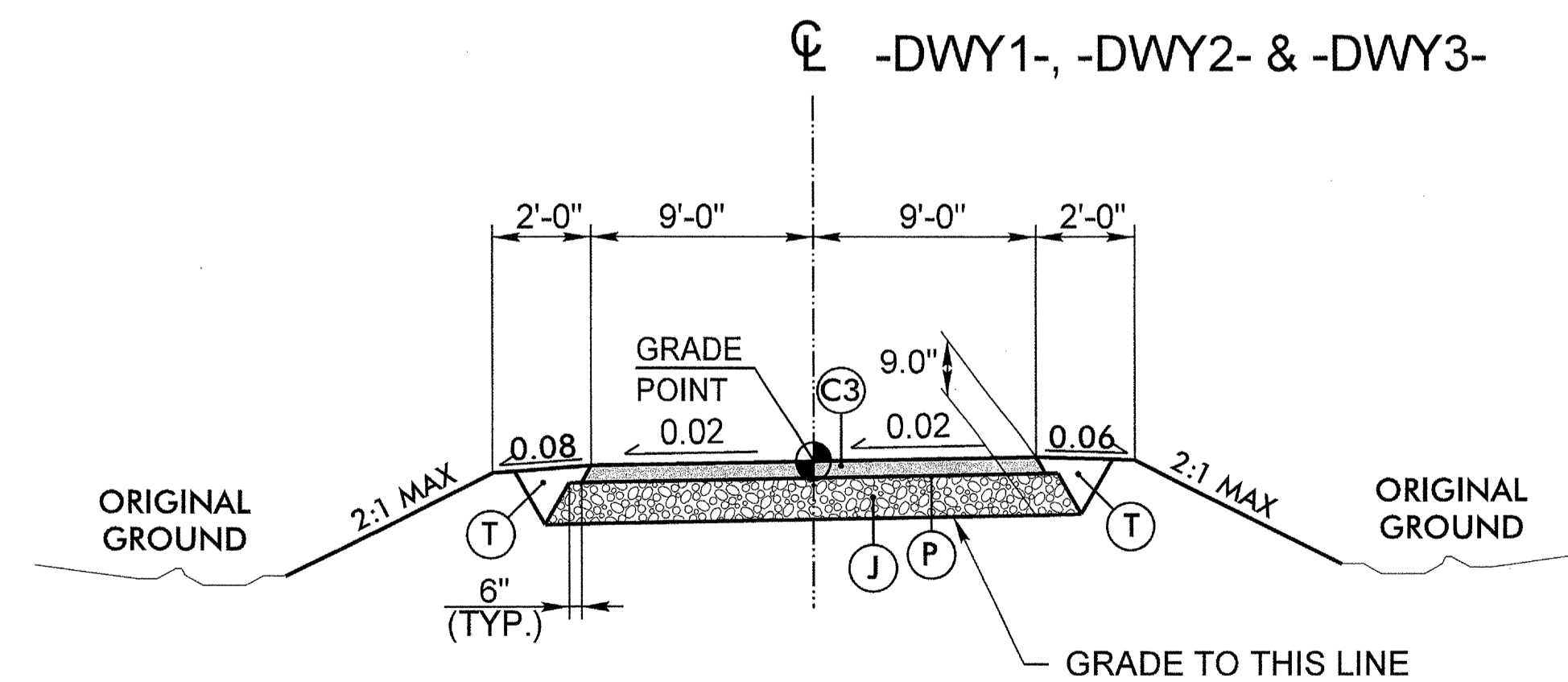

TYPICAL SECTION No. 7

-DWY1- STA. 10+32.22 TO STA. 12+43.85
-DWY2- STA. 10+41.85 TO STA. 11+35.00
-DWY3- STA. 10+12.65 TO STA. 10+90.00

PAVEMENT SCHEDULE	
C1	2.0" Type SF9.5A
C2	1.5" Type S9.5B
C3	3.0" Type S9.5B
C4	Var. Depth Type S9.5B
D1	4.0" Type I19.0B
D2	Var. Depth Type I19.0B
E1	4.0" Type B25.0B
E2	5.5" Type B25.0B
E3	Var. Depth Type B25.0B
J	Prop. Approx 6.0" Aggregate Base Course
P	Prime Coat
R1	2'-6" Curb & Gutter
R2	5" Mono. Island
S	4.0" Concrete Sidewalk
T	Earth Material
U	Existing Pavement
W	Var. Depth Asphalt Pavement

NOTE: PAVEMENT EDGE SLOPES ARE 1:1 UNLESS OTHERWISE INDICATED.

8/15/2012
 G:\OR Projects\0R1050 - Hillsborough Street Bridge\Roadway\Proc\B4656_RDY_02B_TYP.dgn
 11:10:02 AM

REVISIONS

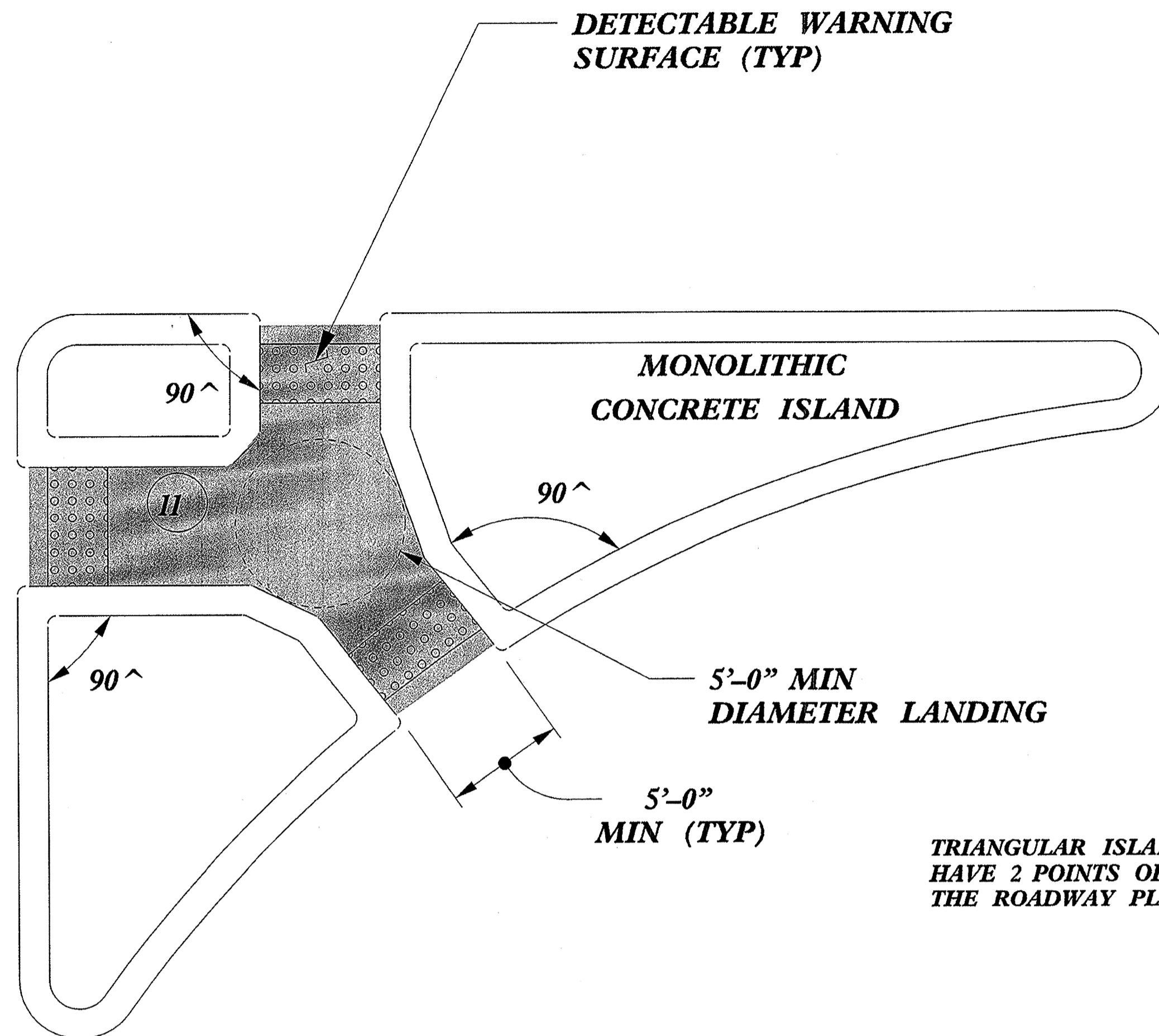

 PAY LIMITS FOR 1 CURB RAMP

TRIANGULAR ISLANDS MAY BE CONSTRUCTED WITH ONLY HAVE 2 POINTS OF ENTRY AND EXIT AS SHOWN IN THE ROADWAY PLANS OR AS DIRECTED BY THE ENGINEER.

TRIANGULAR ISLAND WITH CUT THROUGH

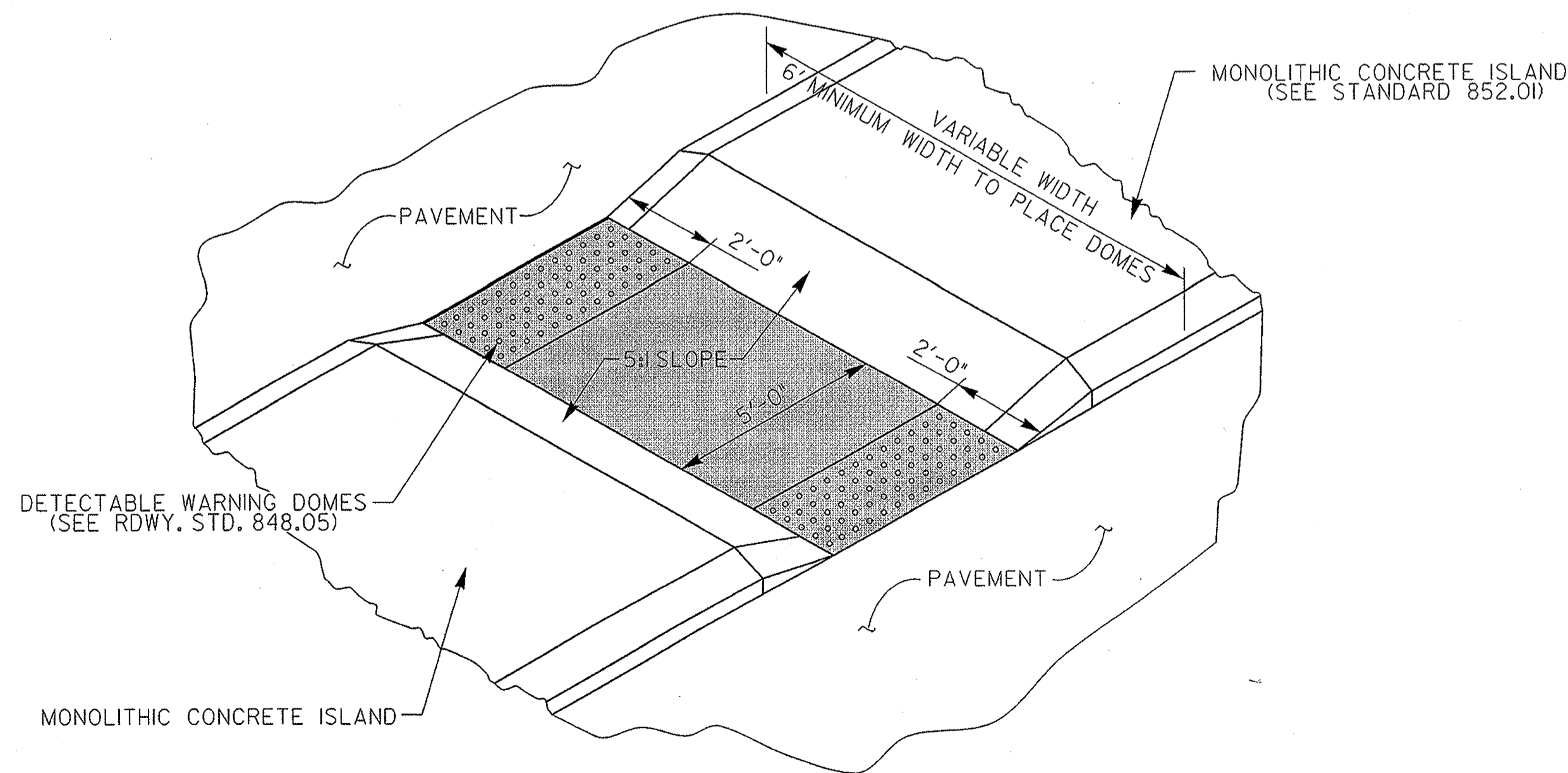

MEDIAN ISLAND WITH CUT THROUGH

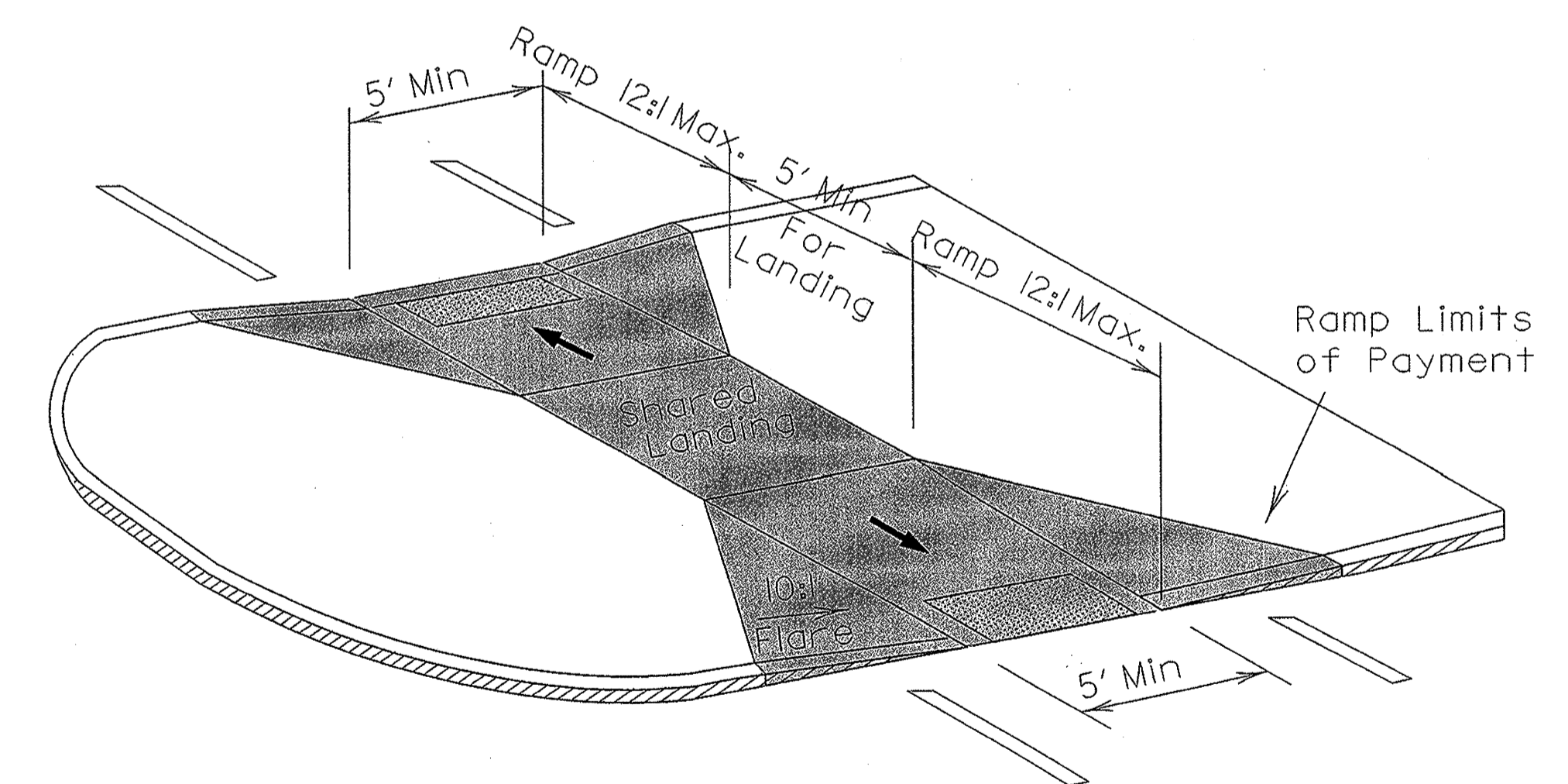

MEDIAN ISLAND CURB RAMPS

CONTRACT STANDARDS AND DEVELOPMENT UNIT Office 919-707-6950 FAX 919-250-4119	
CURB RAMPS Median or Turn Lane Islands	
ORIGINAL BY: J.S. HOWERTON	DATE: 7/7/11
MODIFIED BY: <i>[Signature]</i>	DATE: <i>[Signature]</i>
CHECKED BY: <i>[Signature]</i>	DATE: <i>[Signature]</i>
FILE SPEC: s106/2012CurbRamp/CurbRampDetails.dgn	

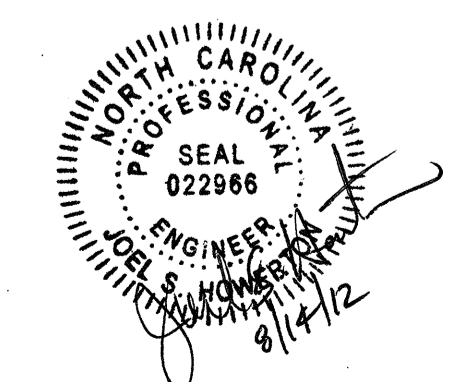

 C:\P\2012\10-15-12\10-15-12.dwg
 10/15/12 10:51:38 AM

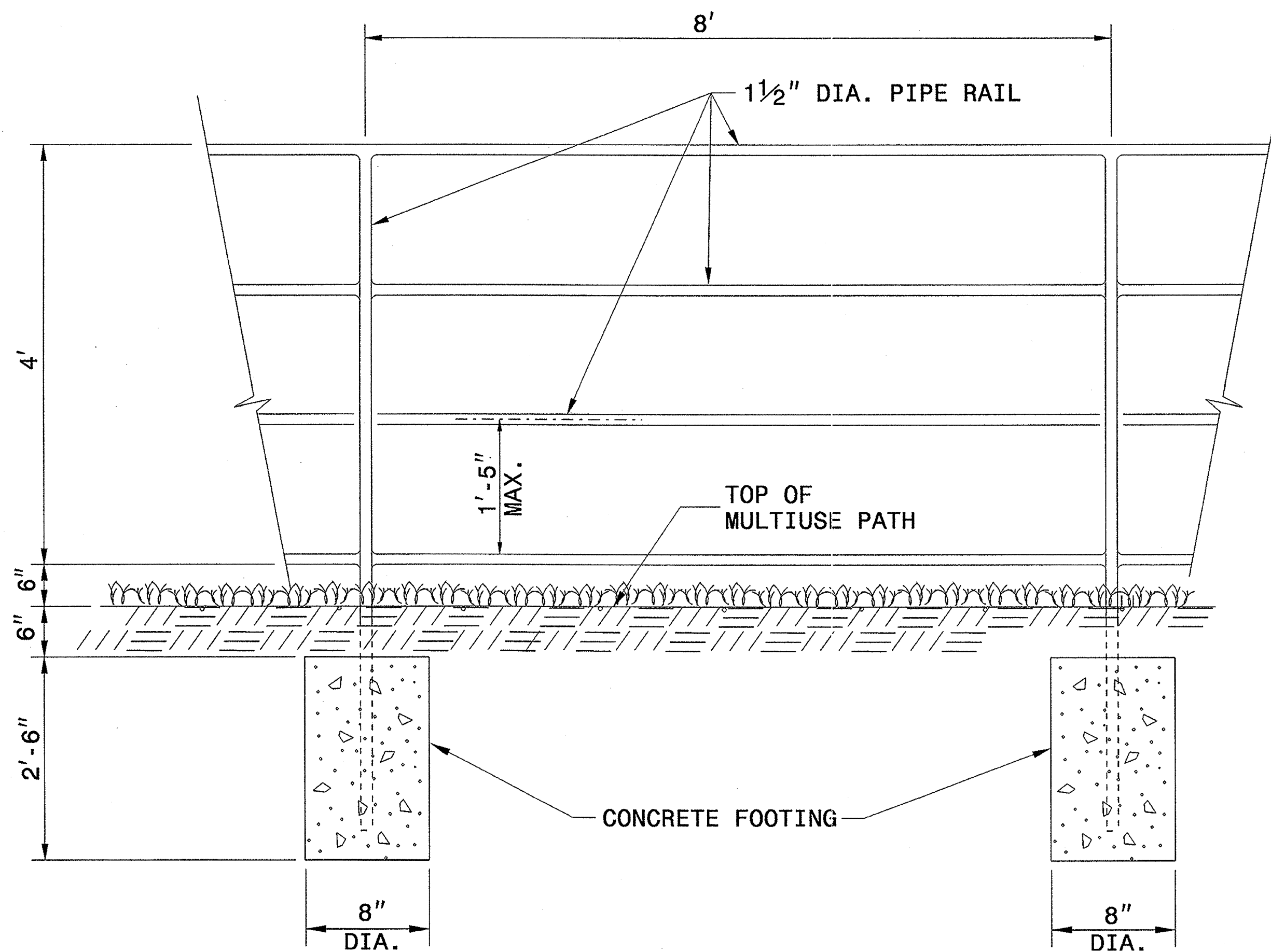

ELEVATION OF PROPOSED PEDESTRIAN HANDRAIL

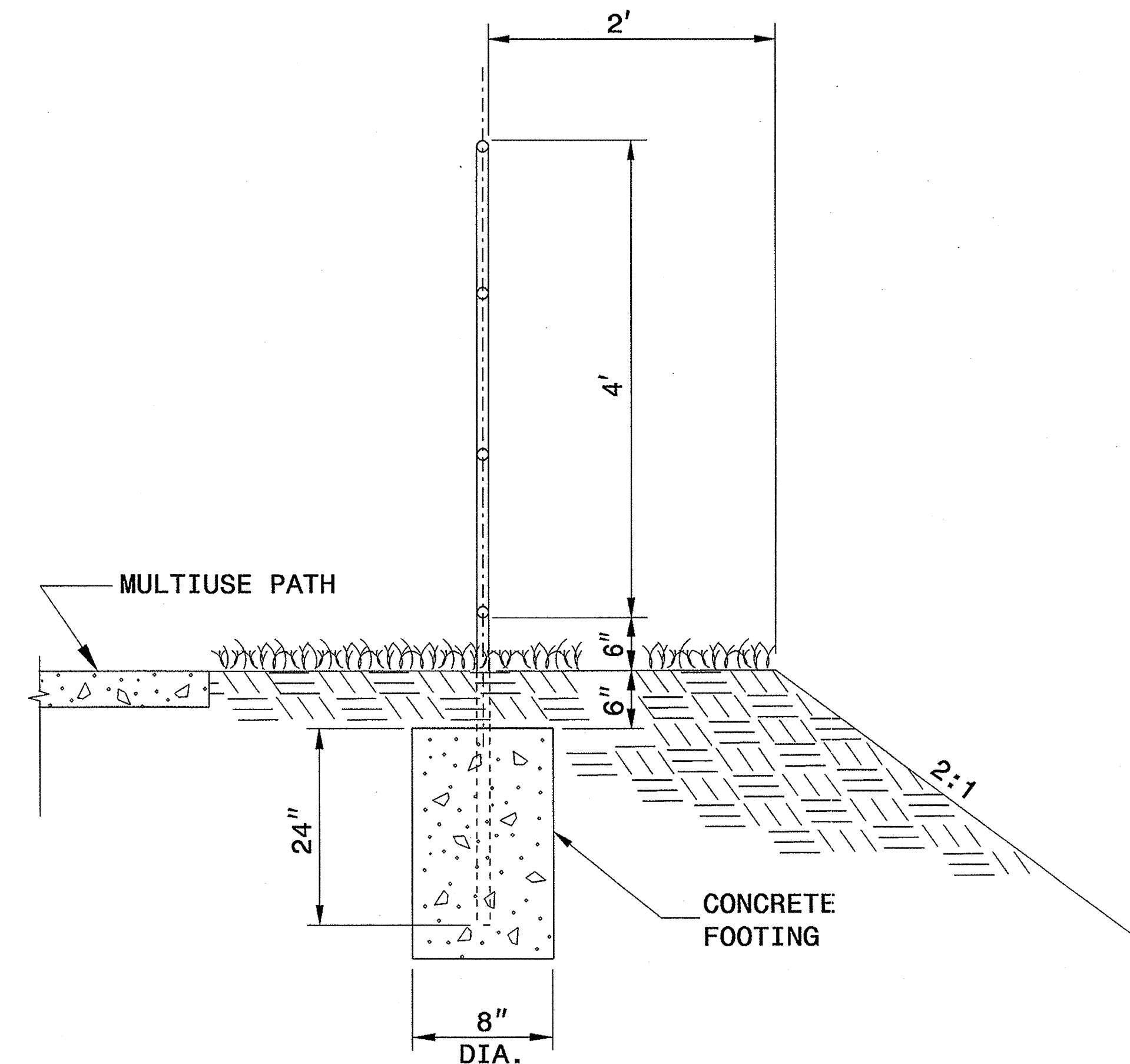

SECTION VIEW

NOTES:

CONSTRUCT PROPOSED STEEL PIPE RAIL OF 1 1/2" DIAMETER SCHEDULE 40 PLAIN END GALVANIZED STEEL PIPE MEETING THE REQUIREMENTS OF ASTM A53.

REPAIR GALVANIZING IN ACCORDANCE WITH SECTION 1076 OF THE NCDOT STANDARD SPECIFICATIONS.

PAINT, IF REQUIRED BY THE ENGINEER, IN ACCORDANCE WITH SECTION 1080 OF THE STANDARD SPECIFICATIONS.

WELD IN ACCORDANCE WITH ARTICLE 1072-18 OF THE STANDARD SPECIFICATIONS.

USE CLASS 'B' CONCRETE FOR HANDRAIL FOOTINGS.

PLACEMENT OF HANDRAIL IN RELATION TO SHOULDER BREAK POINT AND SIDEWALK MAY BE MODIFIED AS DIRECTED BY THE ENGINEER.

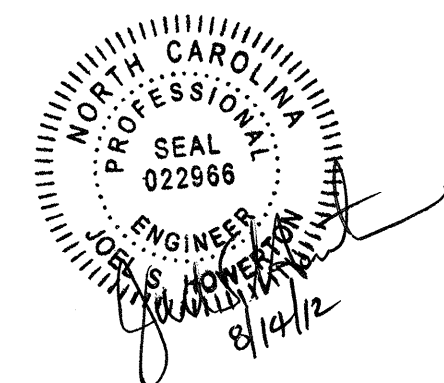

CONTRACT STANDARDS AND DEVELOPMENT UNIT
Office 919-250-4128 FAX 919-250-4119

PROPOSED PEDESTRIAN SAFETY RAIL

ORIGINAL BY: E.E. WARD DATE: 12-99
MODIFIED BY: T.S. Spell DATE: 1-4-05
CHECKED BY: J.S. Howerton DATE: 6/21/11
FILE SPEC.: jshowerton\handrail adjacent to sidewalk.dgn

#####

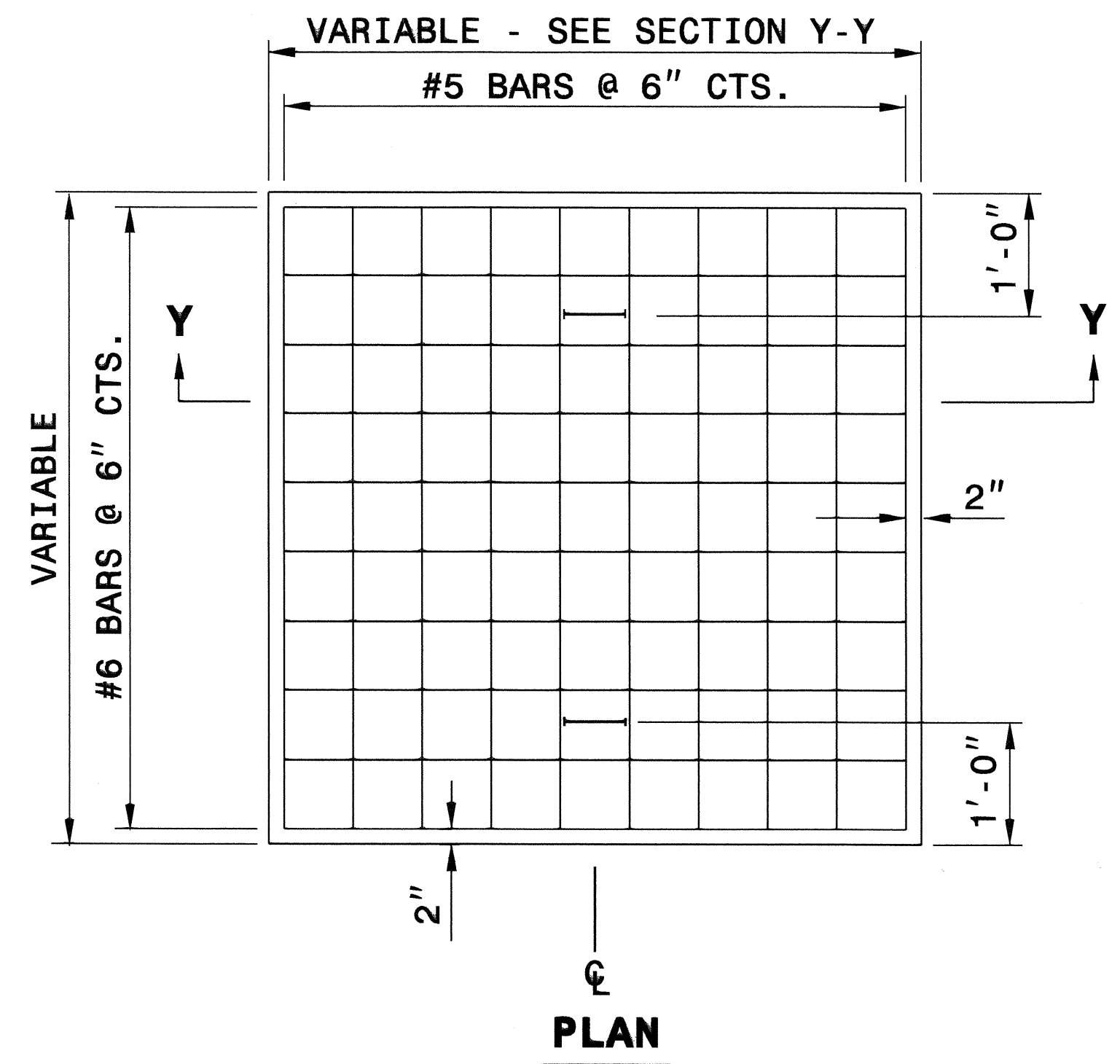
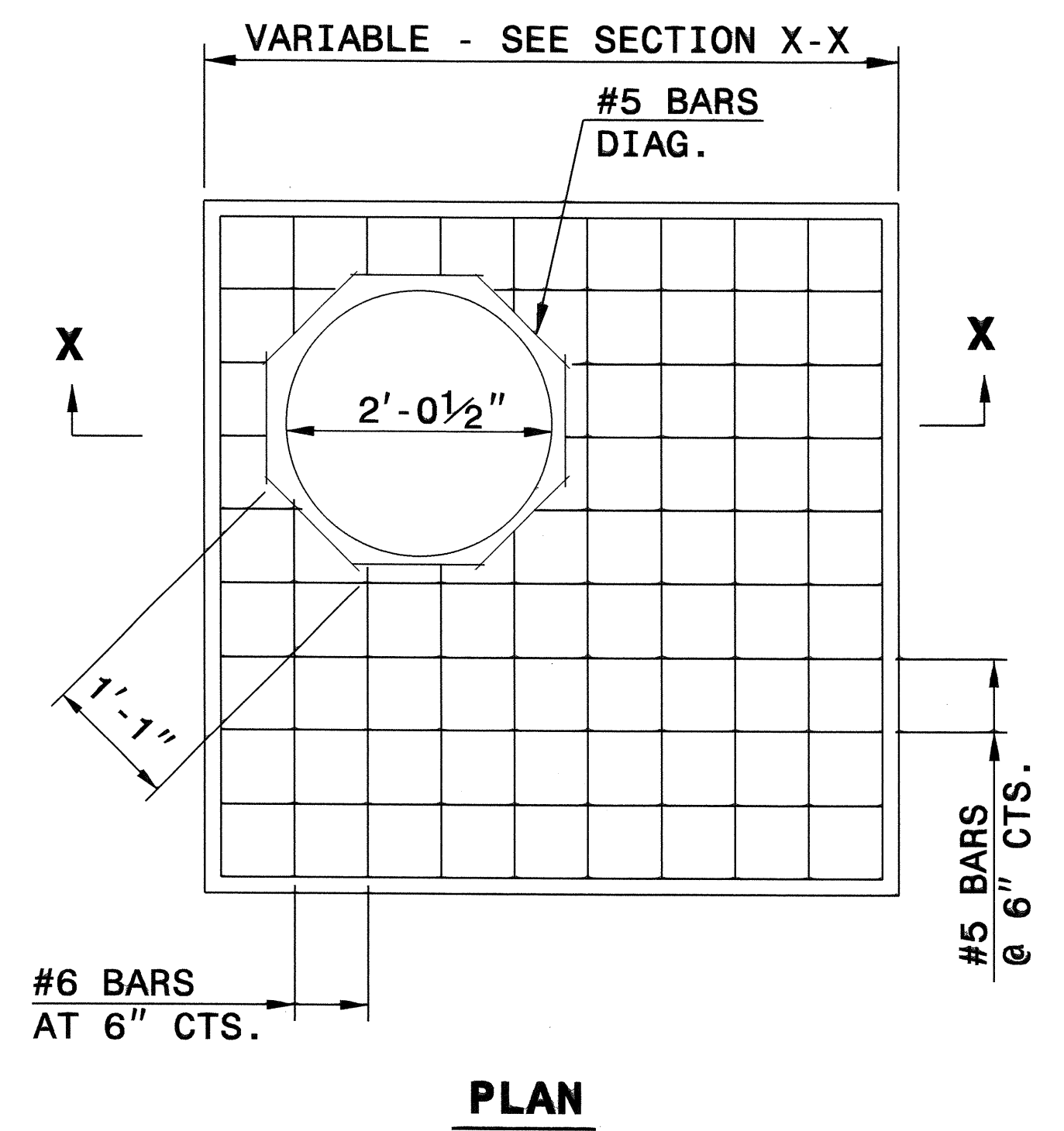
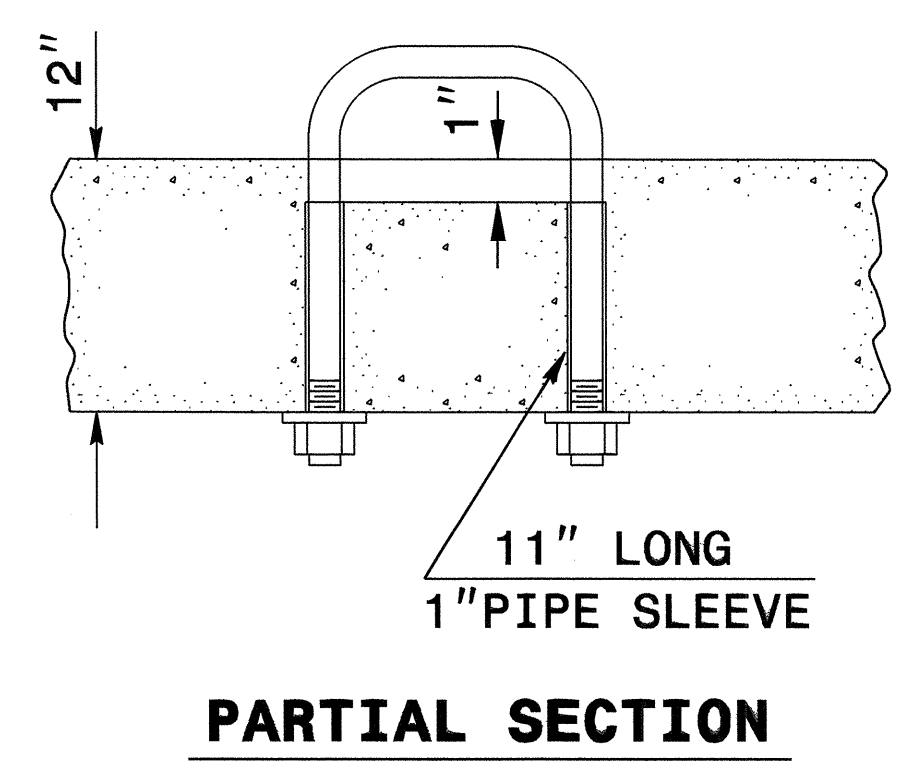

GENERAL NOTES:

CONSTRUCT IN ACCORDANCE WITH SECTION 859 OF THE STANDARD SPECIFICATIONS.

FIELD VERIFY THE DIMENSIONS FOR THE EXISTING BOXES.

BILL OF MATERIALS			
MASONRY			
TOP SLAB CONCRETE CLASS "A"		.037YDS ³	PER FT ²
BRICK MASONRY		.025YDS ³	PER FT ²
REINFORCING STEEL		7.64LBS	PER FT ²
MANHOLE OPTION QUANTITIES			
SIZE	QTY.	LENGTH	REINF. STEEL LBS.
#5 DIAG.	8	1'-1"	9.04

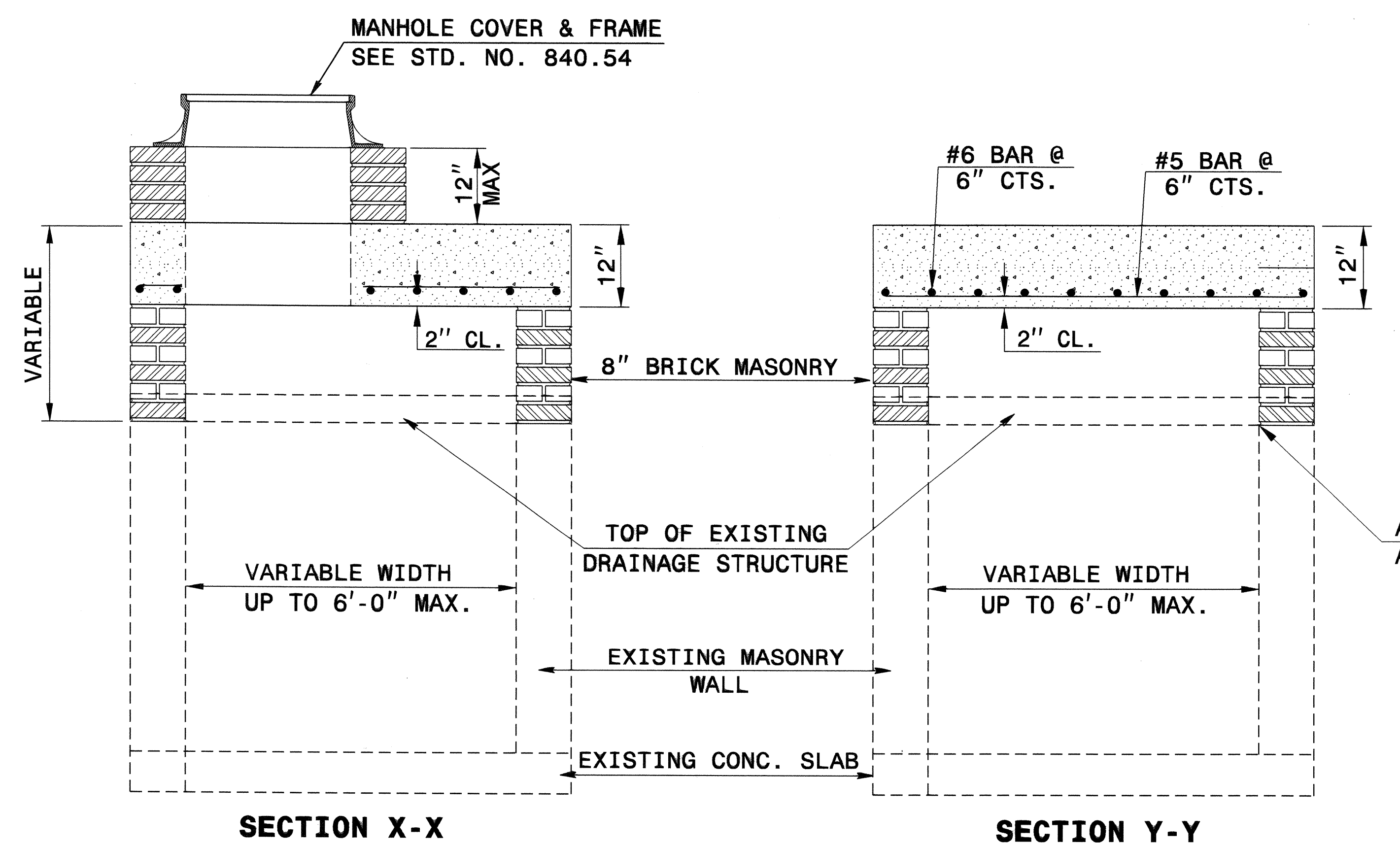
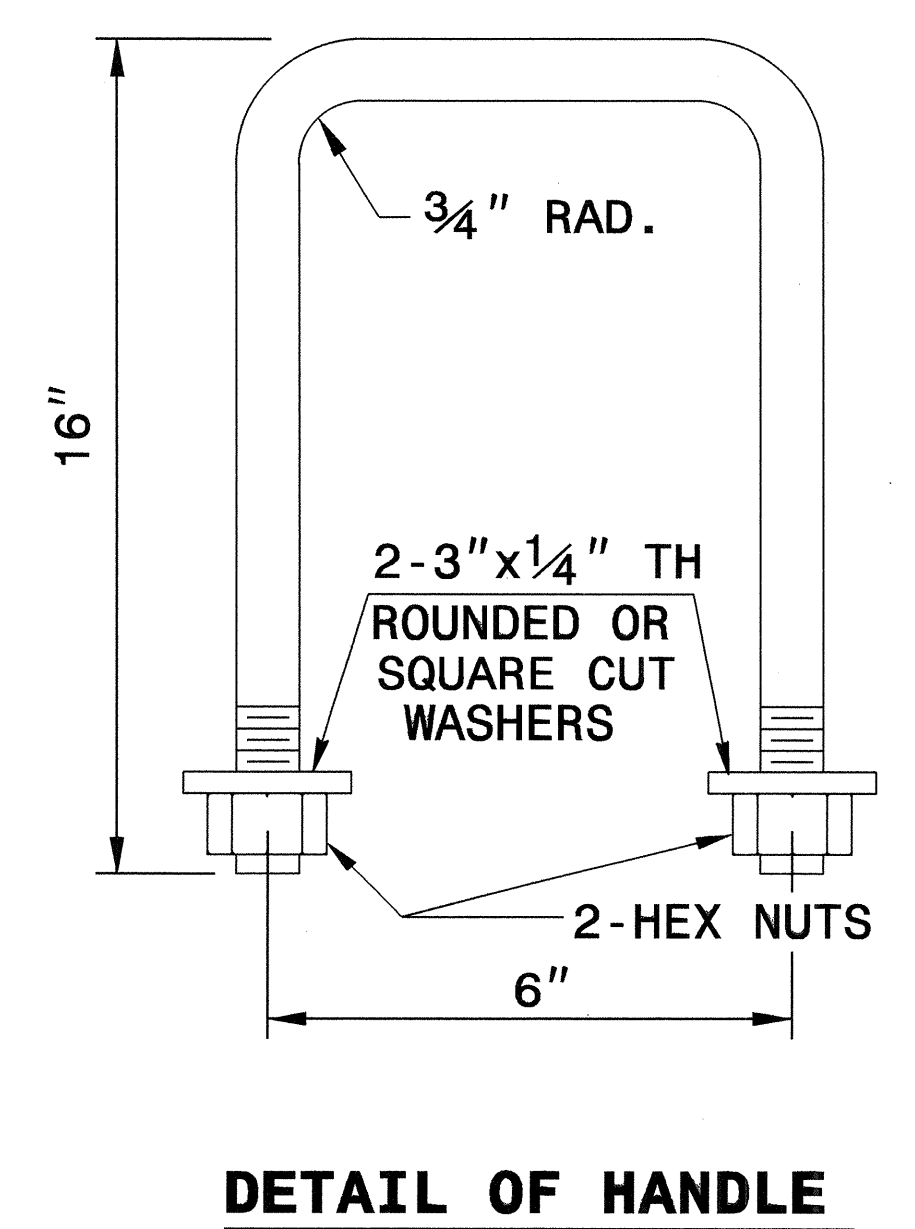

NOTE:

CONCRETE AND REINFORCING STEEL QUANTITIES BASED ON SQUARE FOOT AREA OF THE PROPOSED TOP SLAB FOR THE EXISTING DRAINAGE STRUCTURE.

BRICK MASONRY QUANTITY IS BASED ON THE TOTAL SQUARE FOOTAGE OF EXTERIOR WALL SURFACE AREA TO BE CONSTRUCTED.

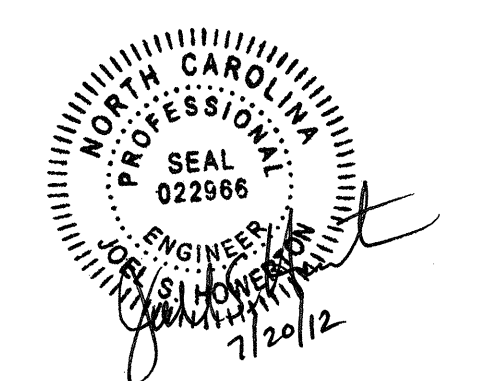

CONTRACT STANDARDS AND DEVELOPMENT UNIT			
Office 919-250-4128		FAX 919-250-4119	
DETAIL TO CONVERT EXISTING DROP INLET OR CATCH BASIN TO TRAFFIC BEARING JUNCTION BOX (MANHOLE OPTIONAL)			
ORIGINAL BY: T.S.S.	DATE: FEB. 2000		
MODIFIED BY: E.E.W.	DATE: NOV. 2001		
CHECKED BY:	DATE:		
FILE SPEC.: w:ericward/usr/details/stand/boxtotbjbe.dgn			

07-DEC-2010 15:09
 S:\Contracts\Special_Details\ericward\usr\details\stand\boxtotbjbe.dgn
 \$\$\$USERNAME\$\$\$

Detail for Temporary Containment of Petroleum Contaminated Soil

Cross-Section View

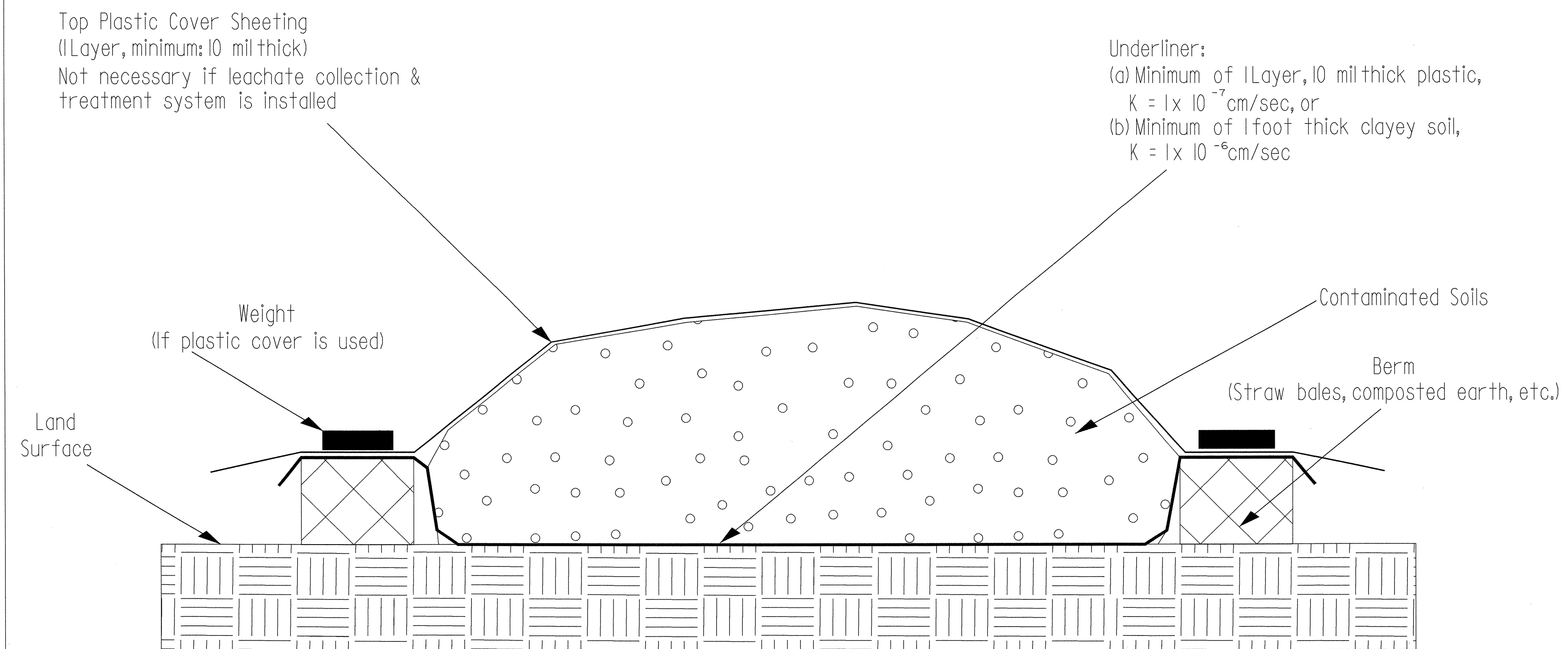

Map View

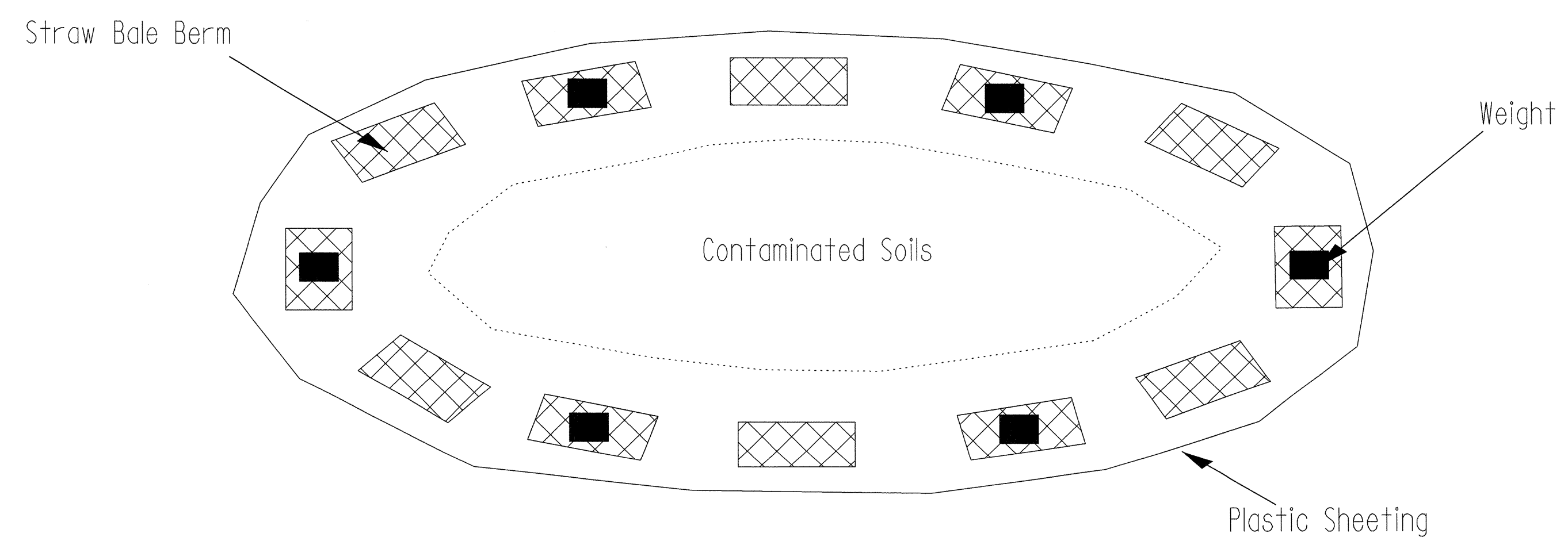

STATE OF NORTH CAROLINA
DIVISION OF HIGHWAYS
ROADWAY SUMMARY OF QUANTITIES FOR CONTRACT - C202235

ItemNumber	Sec #	Quantity	Unit	Description	ItemNumber	Sec #	Quantity	Unit	Description	ItemNumber	Sec #	Quantity	Unit	Description
0000100000-N	800	Lump Sum		MOBILIZATION	2655000000-E	852	420	SY	5" MONOLITHIC CONCRETE ISLANDS (KEYED IN)	6006000000-E	1610	650	TON	STONE FOR EROSION CONTROL, CLASS A
0043000000-N	226	Lump Sum		GRADING	2938000000-N	859	1	EA	CONVERT EXISTING DROP INLET TO JUNCTION BOX WITH MANHOLE	6009000000-E	1610	200	TON	STONE FOR EROSION CONTROL, CLASS B
0050000000-E	226	1	ACR	SUPPLEMENTARY CLEARING & GRUBBING	3360000000-E	863	1,075	LF	REMOVE EXISTING GUARDRAIL	6012000000-E	1610	575	TON	SEDIMENT CONTROL STONE
0057000000-E	226	200	CY	UNDERCUT EXCAVATION	3572000000-E	867	120	LF	CHAIN LINK FENCE RESET	6015000000-E	1615	6.5	ACR	TEMPORARY MULCHING
0134000000-E	240	780	CY	DRAINAGE DITCH EXCAVATION	3575000000-E	SP	620	LF	GENERIC FENCING ITEM PEDESTRIAN SAFETY RAIL	6018000000-E	1620	200	LB	SEED FOR TEMPORARY SEEDING
0195000000-E	265	200	CY	SELECT GRANULAR MATERIAL	3649000000-E	876	350	TON	RIP RAP, CLASS B	6021000000-E	1620	1	TON	FERTILIZER FOR TEMPORARY SEEDING
0196000000-E	270	800	SY	GEOTEXTILE FOR SOIL STABILIZATION	3656000000-E	876	1,830	SY	GEOTEXTILE FOR DRAINAGE	6024000000-E	1622	200	LF	TEMPORARY SLOPE DRAINS
0255000000-E	SP	100	TON	GENERIC GRADING ITEM HAULING & DISPOSAL OF PETROLEUM CONTAMINATED SOIL	4054000000-E	902	1	CY	PLAIN CONCRETE SIGN FOUNDATIONS	6029000000-E	SP	200	LF	SAFETY FENCE
0318000000-E	300	434	TON	FOUNDATION CONDITIONING MATERIAL, MINOR STRUCTURES	4060000000-E	903	201	LB	SUPPORTS, BREAKAWAY STEEL BEAM	6030000000-E	1630	770	CY	SILT EXCAVATION
0320000000-E	300	1,270	SY	FOUNDATION CONDITIONING GEOTEXTILE	4072000000-E	903	1,058	LF	SUPPORTS, 3-LB STEEL U-CHANNEL	6036000000-E	1631	6,000	SY	MATting FOR EROSION CONTROL
0335200000-E	305	3,284	LF	15" DRAINAGE PIPE	4096000000-N	904	3	EA	SIGN ERECTION, TYPE D	6038000000-E	SP	210	SY	PERMANENT SOIL REINFORCEMENT MAT
0335300000-E	305	384	LF	18" DRAINAGE PIPE	4102000000-N	904	44	EA	SIGN ERECTION, TYPE E	6042000000-E	1632	2,220	LF	1/4" HARDWARE CLOTH
0335400000-E	305	24	LF	24" DRAINAGE PIPE	4110000000-N	904	1	EA	SIGN ERECTION, TYPE *** (GROUND MOUNTED) (B)	6071010000-E	SP	750	LF	WATTLE
0453000000-E	310	2	EA	*** PIPE END SECTION (15")	4155000000-N	907	34	EA	DISPOSAL OF SIGN SYSTEM, U-CHANNEL	6071020000-E	SP	250	LB	POLYACRYLAMIDE (PAM)
0453000000-E	310	2	EA	*** PIPE END SECTION (18")	4400000000-E	1110	517	SF	WORK ZONE SIGNS (STATIONARY)	6071030000-E	1640	225	LF	COIR FIBER BAFFLE
0582000000-E	310	40	LF	15" CS PIPE CULVERTS, 0.064" THICK	4405000000-E	1110	1,063	SF	WORK ZONE SIGNS (PORTABLE)	6084000000-E	1660	5	ACR	SEEDING & MULCHING
0986000000-E	SP	48	LF	GENERIC PIPE ITEM 15" I.D. SMOOTH STEEL PIPE, 0.5" WALL THICKNESS, GRADE B	4410000000-E	1110	263	SF	WORK ZONE SIGNS (BARRICADE MOUNTED)	6087000000-E	1660	3	ACR	MOWING
0995000000-E	340	110	LF	PIPE REMOVAL	4415000000-N	1115	3	EA	FLASHING ARROW BOARD	6090000000-E	1661	100	LB	SEED FOR REPAIR SEEDING
1099500000-E	505	200	CY	SHALLOW UNDERCUT	4420000000-N	1120	3	EA	PORTABLE CHANGEABLE MESSAGE SIGN	6093000000-E	1661	0.25	TON	FERTILIZER FOR REPAIR SEEDING
1099700000-E	505	400	TON	CLASS IV SUBGRADE STABILIZATION	4422000000-N	1120	50	DAY	PORTABLE CHANGEABLE MESSAGE SIGN (SHORT TERM)	6096000000-E	1662	150	LB	SEED FOR SUPPLEMENTAL SEEDING
1121000000-E	520	593	TON	AGGREGATE BASE COURSE	4430000000-N	1130	310	EA	DRUMS	6108000000-E	1665	4.25	TON	FERTILIZER TOPDRESSING
1220000000-E	545	600	TON	INCIDENTAL STONE BASE	4435000000-N	1135	50	EA	CONES	6114500000-N	1667	10	MHR	SPECIALIZED HAND MOWING
1275000000-E	600	538	GAL	PRIME COAT	4445000000-E	1145	368	LF	BARRICADES (TYPE III)	6117000000-N	SP	25	EA	RESPONSE FOR EROSION CONTROL
1330000000-E	607	3,470	SY	INCIDENTAL MILLING	4455000000-N	1150	61	DAY	FLAGGER	6123000000-E	1670	0.5	ACR	REFORESTATION
1489000000-E	610	3,540	TON	ASPHALT CONC BASE COURSE, TYPE B25.0B	4480000000-N	1165	2	EA	TMA	7000000000-E	1705	18	EA	PEDESTRIAN SIGNAL HEAD (***, ** SECTION)
1498000000-E	610	3,540	TON	ASPHALT CONC INTERMEDIATE COURSE, TYPE I19.0B	4510000000-N	SP	160	HR	LAW ENFORCEMENT	7060000000-E	1705	7,450	LF	SIGNAL CABLE
1519000000-E	610	3,300	TON	ASPHALT CONC SURFACE COURSE, TYPE S9.5B	4516000000-N	1180	100	EA	SKINNY DRUM					
1525000000-E	610	90	TON	ASPHALT CONC SURFACE COURSE, TYPE SF9.5A	4650000000-N	1251	430	EA	TEMPORARY RAISED PAVEMENT MARKERS					
1575000000-E	620	530	TON	ASPHALT BINDER FOR PLANT MIX	4685000000-E	1205	5,659	LF	THERMOPLASTIC PAVEMENT MARKING LINES (4", 90 MILS)					
1693000000-E	654	20	TON	ASPHALT PLANT MIX, PAVEMENT REPAIR	4686000000-E	1205	5,288	LF	THERMOPLASTIC PAVEMENT MARKING LINES (4", 120 MILS)					
2000000000-N	806	4	EA	RIGHT OF WAY MARKERS	4695000000-E	1205	469	LF	THERMOPLASTIC PAVEMENT MARKING LINES (8", 90 MILS)					
2253000000-E	840	0.447	CY	PIPE COLLARS	4697000000-E	1205	702	LF	THERMOPLASTIC PAVEMENT MARKING LINES (8", 120 MILS)					
2264000000-E	840	0.09	CY	PIPE PLUGS	4710000000-E	1205	1,538	LF	THERMOPLASTIC PAVEMENT MARKING LINES (24", 120 MILS)					
2286000000-N	840	52	EA	MASONRY DRAINAGE STRUCTURES	4721000000-E	1205	32	EA	THERMOPLASTIC PAVEMENT MARKING CHARACTER (120 MILS)					
2308000000-E	840	4.51	LF	MASONRY DRAINAGE STRUCTURES	4725000000-E	1205	50	EA	THERMOPLASTIC PAVEMENT MARKING SYMBOL (90 MILS)					
2364000000-N	840	7	EA	FRAME WITH TWO GRATES, STD 840.16	4810000000-E	1205	36,698	LF	PAINT PAVEMENT MARKING LINES (4")					
2374000000-N	840	7	EA	FRAME WITH GRATE & HOOD, STD 840.03, TYPE ** (E)	4825000000-E	1205	120	LF	PAINT PAVEMENT MARKING LINES (12")					
2374000000-N	840	20	EA	FRAME WITH GRATE & HOOD, STD 840.03, TYPE ** (F)	4835000000-E	1205	1,628	LF	PAINT PAVEMENT MARKING LINES (24")					
2374000000-N	840	18	EA	FRAME WITH GRATE & HOOD, STD 840.03, TYPE ** (G)	4840000000-N	1205	16	EA	PAINT PAVEMENT MARKING CHARACTER					
2396000000-N	840	1	EA	FRAME WITH COVER, STD 840.54	4845000000-N	1205	102	EA	PAINT PAVEMENT MARKING SYMBOL					
2451000000-N	852	4	EA	CONCRETE TRANSITIONAL SECTION FOR DROP INLET	4875000000-N	1205	3	EA	REMOVAL OF PAVEMENT MARKING SYMBOLS & CHARACTERS					
2535000000-E	846	400	LF	***X*** CONCRETE CURB (8" X 12")	4900000000-N	1251	146	EA	PERMANENT RAISED PAVEMENT MARKERS					
2549000000-E	846	6,190	LF	2'-6" CONCRETE CURB & GUTTER	5691200000-E	1520	8	LF	6" SANITARY GRAVITY SEWER					
2591000000-E	848	3,220	SY	4" CONCRETE SIDEWALK	5691300000-E	1520	271	LF	8" SANITARY GRAVITY SEWER					
2600000000-N	SP	2	EA	RETROFIT EXISTING CURB RAMP	5775000000-E	1525	2	EA	4" DIA UTILITY MANHOLE					
2605000000-N	848	16	EA	CONCRETE CURB RAMP	5781000000-E	1525	4.11	LF	UTILITY MANHOLE WALL, 4" DIA					
2612000000-E	848	200	SY	6" CONCRETE DRIVEWAY	5816000000-N	1530	1	EA	ABANDON UTILITY MANHOLE					
					6000000000-E	1605	7,500	LF	TEMPORARY SILT FENCE					

7/26/2012 8:12:20 PM G:\OR Projects\ORI050 - Hillsborough Street Bridge\Roadway\Proj\B4656_RDY_03.dgn

**STATE OF NORTH CAROLINA
SUMMARY OF QUANTITIES**

PROJECT REFERENCE No.	SHEET No.
B-4656	3 (2 of 2)

ItemNumber	Sec #	Quantity	Unit	Description
712000000-E	1705	36	EA	VEHICLE SIGNAL HEAD (12", 3 SECTION)
713200000-E	1705	1	EA	VEHICLE SIGNAL HEAD (12", 4 SECTION)
720400000-N	1705	15	EA	LOUVER
726400000-E	1710	1,900	LF	MESSENGER CABLE (3/8")
727900000-E	1715	2,820	LF	TRACER WIRE
728800000-E	1715	50	LF	PAVED TRENCHING (*****) (1, 2")
730000000-E	1715	1,030	LF	UNPAVED TRENCHING (*****) (1, 2")
730000000-E	1715	600	LF	UNPAVED TRENCHING (*****) (2, 1-1/4")
730000000-E	1715	350	LF	UNPAVED TRENCHING (*****) (2, 2")
730000000-E	1715	75	LF	UNPAVED TRENCHING (*****) (FOR TEMPORARY LEAD-IN)
730100000-E	1715	200	LF	DIRECTIONAL DRILL (*****) (1, 2")
730100000-E	1715	860	LF	DIRECTIONAL DRILL (*****) (2, 1-1/4")
730100000-E	1715	60	LF	DIRECTIONAL DRILL (*****) (2, 2")
732400000-N	1716	27	EA	JUNCTION BOX (STANDARD SIZE)
734800000-N	1716	7	EA	JUNCTION BOX (OVER-SIZED, HEAVY DUTY)
736000000-N	1720	4	EA	WOOD POLE
737200000-N	1721	10	EA	GUY ASSEMBLY
742000000-E	1722	10	EA	2" RISER WITH WEATHERHEAD
743000000-N	1722	1	EA	HEAT SHRINK TUBING RETROFIT KIT
744400000-E	1725	4,450	LF	INDUCTIVE LOOP SAWCUT
745600000-E	1726	11,150	LF	LEAD-IN CABLE (*****) (14-2)
751600000-E	1730	3,450	LF	COMMUNICATIONS CABLE (**FIBER) (48)
754000000-N	1731	2	EA	SPLICE ENCLOSURE

ItemNumber	Sec #	Quantity	Unit	Description
756410000-N	1732	2	EA	FIBER-OPTIC TRANSCIVER, SELF-HEALING RING
756600000-N	1733	3	EA	DELINEATOR MARKER
757600000-N	SP	12	EA	METAL STRAIN SIGNAL POLE
761300000-N	SP	12	EA	SOIL TEST
761410000-E	SP	96	CY	DRILLED PIER FOUNDATION
763600000-N	1745	23	EA	SIGN FOR SIGNALS
764220000-N	1743	11	EA	TYPE II PEDESTAL WITH FOUNDATION
768400000-N	1750	3	EA	SIGNAL CABINET FOUNDATION
775600000-N	1751	3	EA	CONTROLLER WITH CABINET (TYPE 2070L, BASE MOUNTED)
778000000-N	1751	12	EA	DETECTOR CARD (TYPE 2070L)
790100000-N	1753	3	EA	CABINET BASE EXTENDER
798000000-N	SP	1	EA	GENERIC SIGNAL ITEM DROP CABLE ASSEMBLY
798000000-N	SP	1	EA	GENERIC SIGNAL ITEM ETHERNET EDGE SWITCH
799000000-E	SP	910	LF	GENERIC SIGNAL ITEM REMOVE & REINSTALL EXISTING DROP CABLE ASSEMBLY
803500000-N	402	Lump Sum		REMOVAL OF EXISTING STRUCTURE AT STATION ***** (24+00 -L2-)

COMPUTED BY: CWV 8/15/2012
 CHECKED BY: WET 8/15/2012

SUMMARY OF EARTHWORK

STATION	UNCL. EXCAV.	UNDERCUT EXCAV.	EMBANK. +%	BORROW	WASTE
-L1- Sta 12+00 to 27+50	1,857		1,840		17
-L2- Sta 12+50 to 29+00	1,901		937		964
-Y1- Sta 10+00 to 18+50	3,634		413		3,221
-Y2- Sta 11+00 to 17+00	385		473	88	
SUBTOTALS	7,777		3,663	88	4,202
LOSS DUE TO CLEARING & GRUBBING	-389				-389
WASTE IN LIEU OF BORROW				-88	-88
SUBTOTALS	7,388		3,663	0	3,725
GRAND TOTALS	7,388				
SAY	7,400 CY				

DRAINAGE DITCH EXCAVATION = 780 CY
 SHOULDER BORROW = 450 CY
 UNCERCUT EXCAVATION = 200 CY
 SHALLOW UNDERCUT = 200 CY

Earthwork quantities are calculated by the Roadway Design Unit. These earthwork quantities are based in part on subsurface data provided by the Geotechnical Engineering Unit.

PAVEMENT REMOVAL SUMMARY

SURVEY LINE	STATION	STATION	LOCATION LT/RT/CL	YD ²
-L1-	17+10	22+50	LT	1,091
-L1-	25+40	25+60	LT	40
-L2-	19+20	19+60	RT	37
-L2-	20+20	20+65	RT	19
-L2-	19+75	23+65	LT	1,235
-Y1-	10+90	13+25	LT	572
-Y1-	12+95	15+30	LT	686
			TOTAL:	3,680
			SAY:	3,680

GUARDRAIL REMOVAL SUMMARY

SURVEY LINE	STATION	STATION	LOCATION LT/RT/CL	YD ²
-L1-	18+95	22+16	LT	335
-L1-	19+15	22+55	LT	360
-Y1-	10+85	13+80	LT	335
-Y1-	10+85	11+20	LT	42
			TOTAL:	1,072
			SAY:	1,075

NOTE: Approximate quantities only. Unclassified Excavation, Fine Grading, Clearing and Grubbing, Shoulder Borrow and Removal of Existing Pavement will be paid for at the contract lump sum price for "Grading".

8/15/2012
 G:\OR Projects\011050 - Hillsborough Street Bridge\Roadway\Proj\B4656_R0Y_03D_SUMMARY.dgn
 11:02:22 AM

REVISIONS

STATE OF NORTH CAROLINA
DIVISION OF HIGHWAYS

PARCEL INDEX SHEET

PARCEL NO.	SHEET NO.	PROPERTY OWNER NAME
6	4	15 JONES FRANKLIN ROAD, LLC.
9	4 & 5	CASTLEBURY CAR WASH, LLC
11	4 & 5	CASTLEBURY, III, FRANK D.
12	4 & 5	STANSBURY, FRANK E.
15	4 & 5	RISING SUN POOLS, INC.
16	4 & 5	BORO, LLC.
17	4 & 5	HOLLEMAN, JAMES MICHAEL
18	5	BUCHANAN, CURTIS P.
19	5	LEE, STANLEY C.

7/26/2012
G:\DR Projects\0R1050 - Hillsborough Street Bridge\Roadway\Proj\B4656_RDY_03E_ROW.dgn
6:32:12 PM

REVISIONS



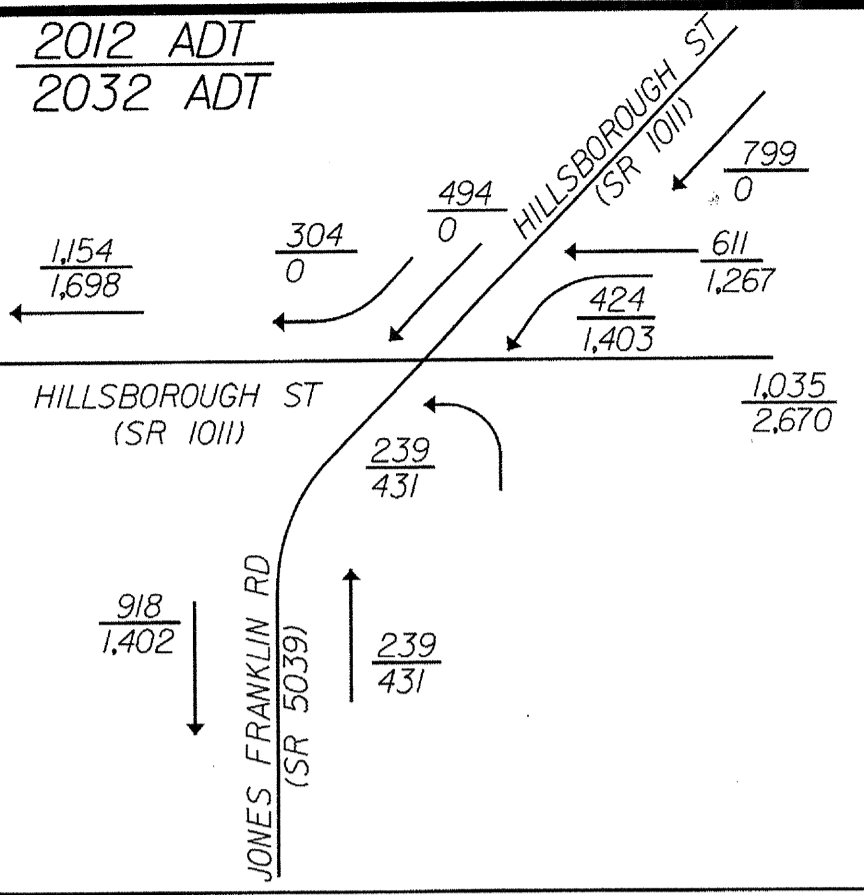

CURVE DATA FOR -L2-	CURVE DATA FOR -Y2-	CURVE DATA FOR -DWY2-	CURVE DATA FOR -DWY1-
PI Sta 16+44.07 $\Delta = 5' 01'' 39.1''$ (RT) $D = 1' 09'' 27.0''$ $L = 434.35'$ $T = 217.31'$ $R = 4950.00'$ $Se = 2.00$ $DS = 50$ MPH	PI Sta 12+78.58 $\Delta = 33' 38'' 50.1''$ (RT) $D = 1' 41'' 34.9''$ $L = 287.76'$ $T = 148.16'$ $R = 490.00'$ $Se = Exist.$	PI Sta 16+13.65 $\Delta = 25' 56'' 30.0''$ (LT) $D = 1' 37'' 30.7''$ $L = 190.16'$ $T = 96.74'$ $R = 420.00'$ $Se = Exist.$	PI Sta 10+95.37 $\Delta = 23' 52'' 04.2''$ (LT) $D = 67' 24'' 24.5''$ $L = 35.41'$ $T = 17.96'$ $R = 85.00'$
CURVE DATA FOR -L1- PI Sta 12+33.31 $\Delta = 15' 37'' 05.0''$ (LT) $D = 4' 53'' 49.5''$ $L = 318.93'$ $T = 160.46'$ $R = 1170.00'$ $Se = Exist. (13.90)$ $DS = 50$ MPH	PI Sta 16+74.20 $\Delta = 17' 05'' 55.0''$ (LT) $D = 4' 28'' 34.4''$ $L = 381.99'$ $T = 219.21'$ $R = 1280.00'$ $Se = 3.80$ $DS = 50$ MPH	PI Sta 26+68.14 $\Delta = 21' 48'' 22.6''$ (RT) $D = 5' 02'' 05.2''$ $L = 433.11'$ $T = 219.21'$ $R = 1138.00'$ $Se = Exist. (10.00)$ $DS = 60$ MPH	PI Sta 11+86.47 $\Delta = 45' 53'' 49.1''$ (RT) $D = 76' 23'' 39.7''$ $L = 60.08'$ $T = 31.76'$ $R = 75.00'$ $Se = Exist.$

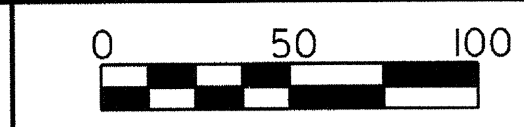

PROJECT REFERENCE NO. B-4656	SHEET NO. 4
ROADWAY DESIGN ENGINEER	HYDRAULICS ENGINEER

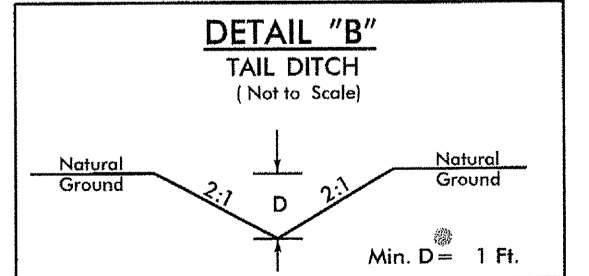
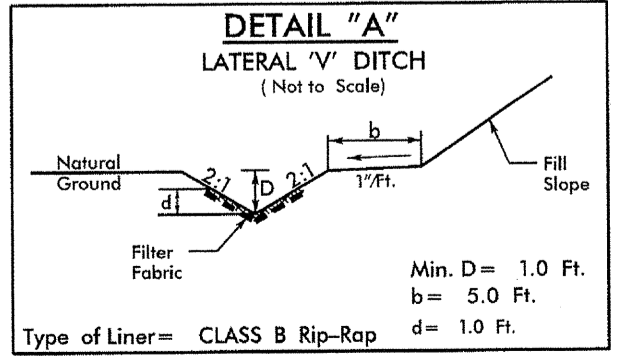
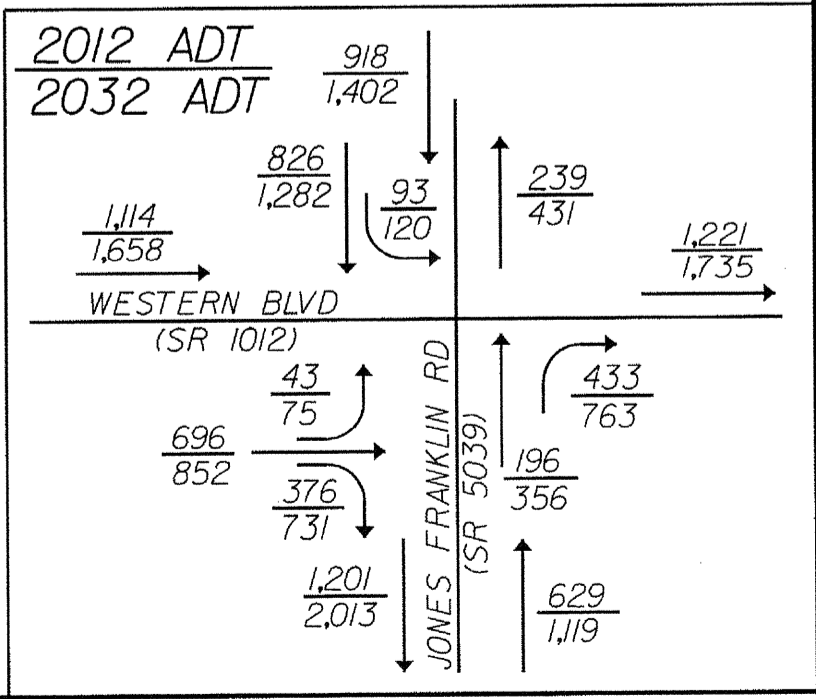
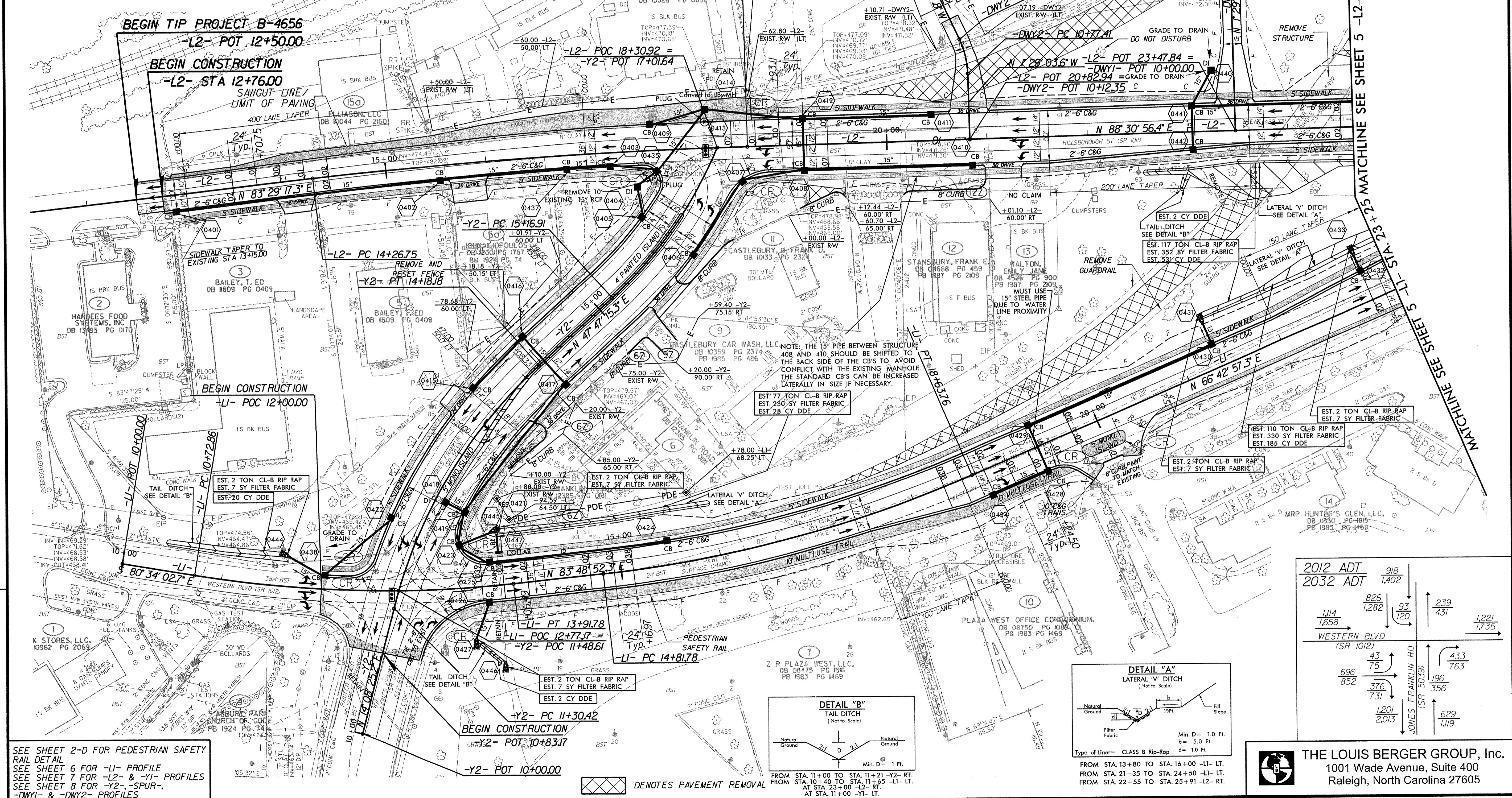

SEE SHEET 2-D FOR PEDESTRIAN SAFETY RAIL DETAIL
 SEE SHEET 6 FOR -L1- PROFILE
 SEE SHEET 7 FOR -L2- & -Y1- PROFILES
 SEE SHEET 8 FOR -Y2-, -SPUR-, -DWY1- & -DWY2- PROFILES

DENOTES PAVEMENT REMOVAL

FROM STA. 13+80 TO STA. 16+00 -L1- LT.
 FROM STA. 21+35 TO STA. 24+50 -L1- LT.
 FROM STA. 22+55 TO STA. 25+91 -L2- RT.

THE LOUIS BERGER GROUP, Inc.
 1001 Wade Avenue, Suite 400
 Raleigh, North Carolina 27605

8/28/2012
 G:\OR Projects\01050 - Hillsborough Street Bridge (Roadway)\Proj\B4656_RDY_04_PSH.dgn
 10:47:35 AM

REVISIONS

MATCHLINE SEE SHEET 5 -L2- STA. 24+65

MATCHLINE SEE SHEET 5 -L1- STA. 13+25

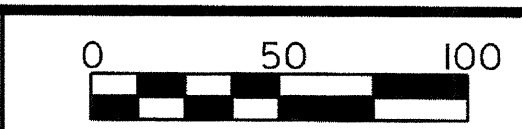

PROJECT REFERENCE NO. B-4656	SHEET NO. 5
RW SHEET NO.	
ROADWAY DESIGN ENGINEER 	HYDRAULICS ENGINEER
REGISTERED ENGINEER 07/11/12	REGISTERED ENGINEER 07/11/12

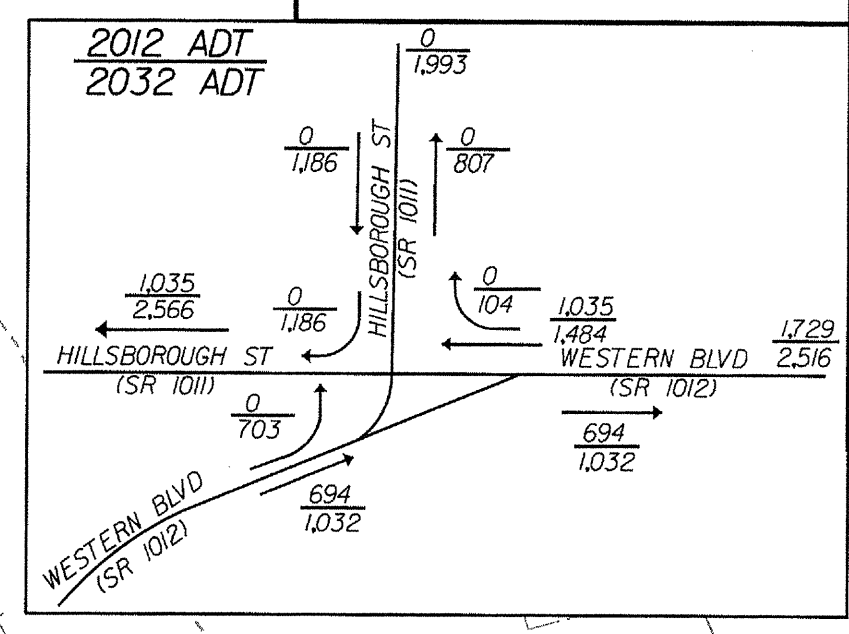
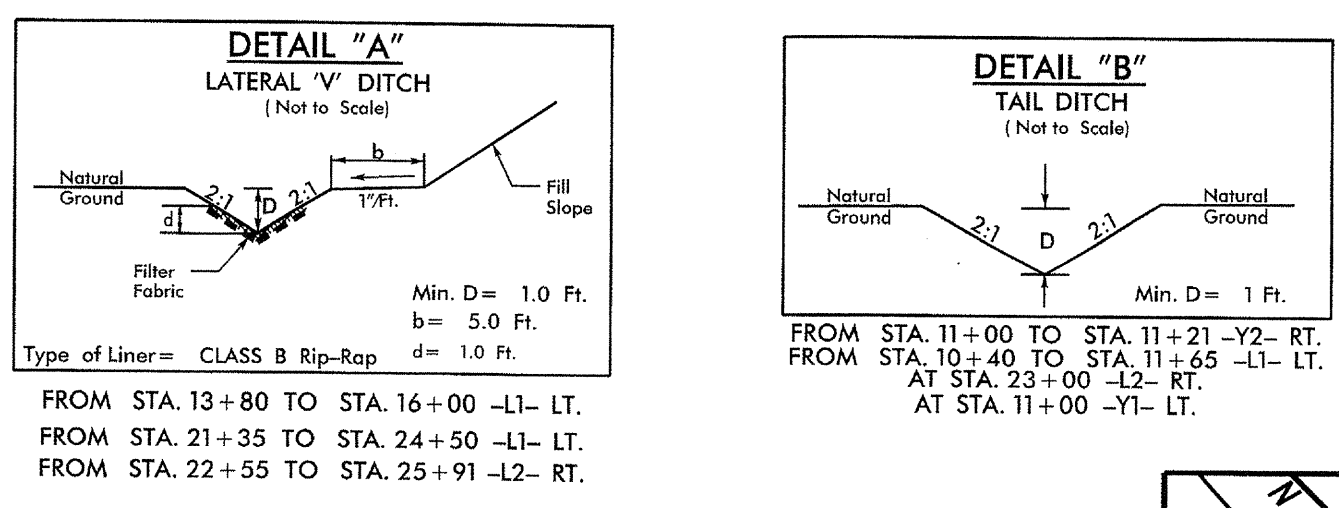

MATCHLINE SEE SHEET 4 -L1- STA. 23+25
 MATCHLINE SEE SHEET 4 -L2- STA. 24+65

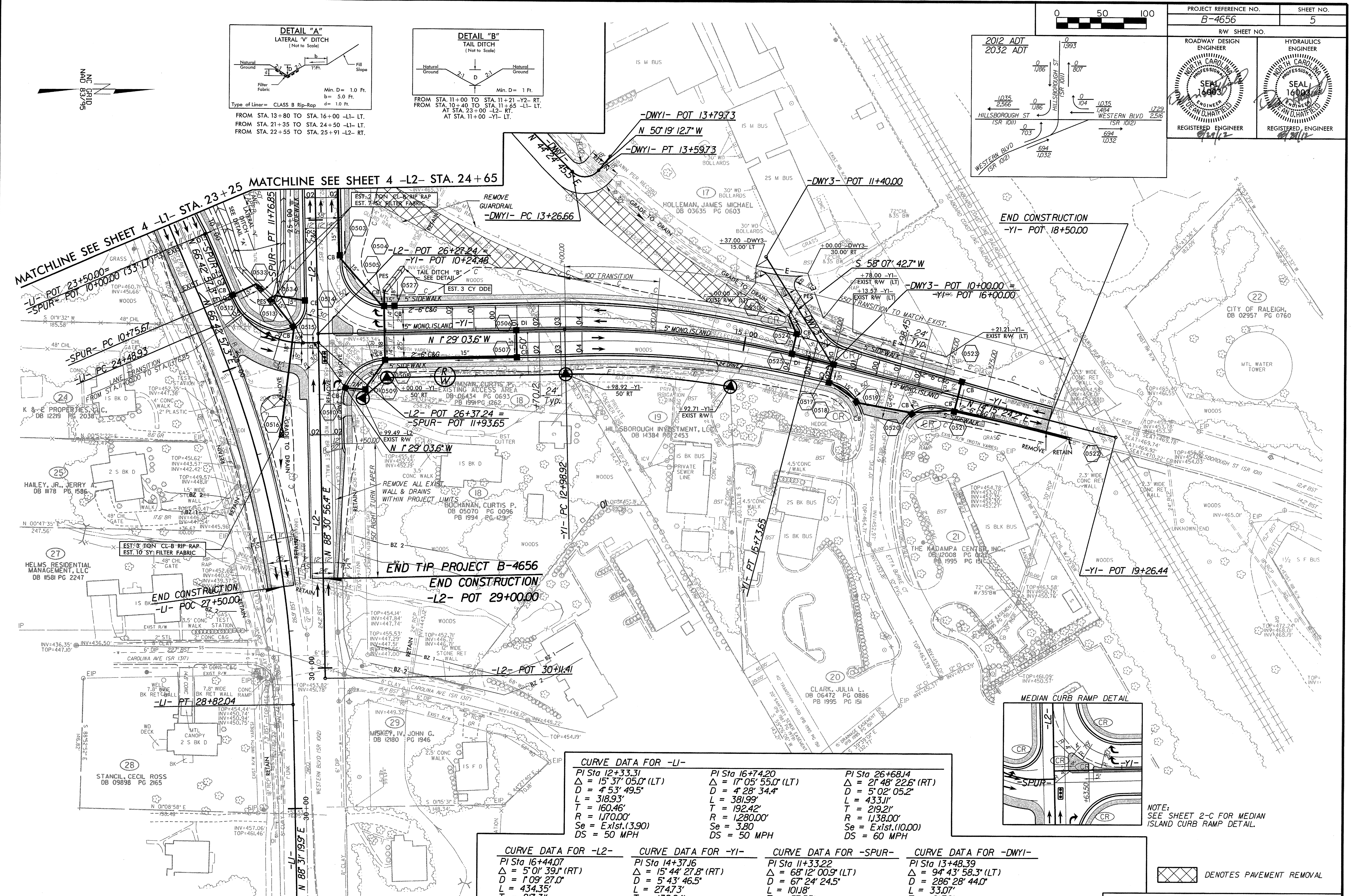

CURVE DATA FOR -L1-			
PI Sta 12+33.31	PI Sta 16+74.20	PI Sta 26+68.14	
$\Delta = 15^{\circ} 37' 05.0''$ (LT)	$\Delta = 17^{\circ} 05' 55.0''$ (LT)	$\Delta = 21^{\circ} 48' 22.6''$ (RT)	
D = 4' 53' 49.5"	D = 4' 28' 34.4"	D = 5' 02' 05.2"	
L = 318.93'	L = 381.99'	L = 433.11'	
T = 160.46'	T = 192.42'	T = 219.21'	
R = 1170.00'	R = 1280.00'	R = 1138.00'	
Se = Exist.(3.90)	Se = 3.80	Se = Exist.(10.00)	
DS = 50 MPH	DS = 50 MPH	DS = 60 MPH	

CURVE DATA FOR -L2-	CURVE DATA FOR -Y1-	CURVE DATA FOR -SPUR-	CURVE DATA FOR -DWY1-
PI Sta 16+44.07	PI Sta 14+37.16	PI Sta 11+33.22	PI Sta 13+48.39
$\Delta = 5^{\circ} 01' 39.1''$ (RT)	$\Delta = 15^{\circ} 44' 27.8''$ (RT)	$\Delta = 68^{\circ} 12' 00.9''$ (LT)	$\Delta = 94^{\circ} 43' 58.3''$ (LT)
D = 1' 09' 27.0"	D = 5' 43' 46.5"	D = 67' 24' 24.5"	D = 286' 28' 44.0"
L = 434.35'	L = 274.73'	L = 1011.8'	L = 330.7'
T = 217.31'	T = 138.24'	T = 57.55'	T = 217.2'
R = 4950.00'	R = 1000.00'	R = 85.00'	R = 20.00'
Se = 2.00	Se = 4.00	Se = 4.00	
DS = 50 MPH	DS = 50 MPH	DS = 15 MPH	

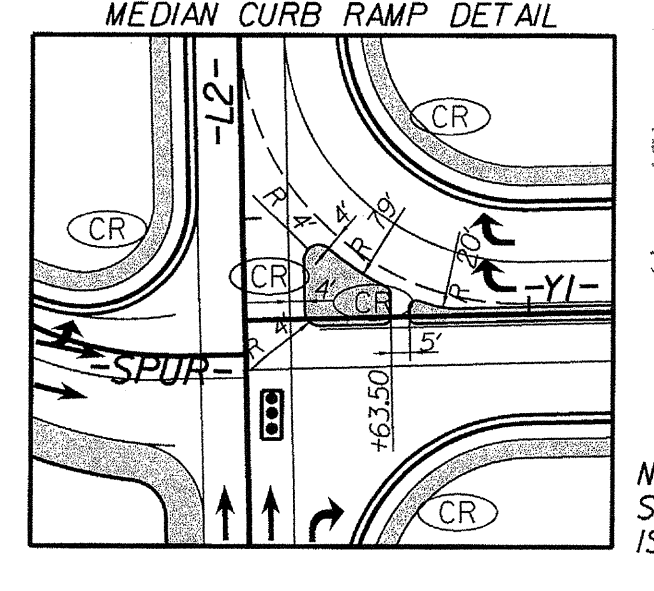

NOTE: SEE SHEET 2-C FOR MEDIAN ISLAND CURB RAMP DETAIL.

DENOTES PAVEMENT REMOVAL

THE LOUIS BERGER GROUP, Inc.
 1001 Wade Avenue, Suite 400
 Raleigh, North Carolina 27605

SEE SHEET 6 FOR -L1- PROFILE
 SEE SHEET 7 FOR -L2- & -Y1- PROFILES
 SEE SHEET 8 FOR -Y2-, -SPUR-,
 -DWY1- & -DWY2- PROFILES

8/28/2012 G:\OR Projects\DR1050 - Hillsborough Street Bridge\Roadway\Proj\B4656.RDY_05_PSH.dgn
 REVISIONS
 10:47:38 AM



THE LOUIS BERGER GROUP, Inc.
1001 Wade Avenue, Suite 400
Raleigh, North Carolina 27605

PROJECT REFERENCE NO. B-4656	SHEET NO. 6
RW SHEET NO.	
ROADWAY DESIGN ENGINEER 	HYDRAULICS ENGINEER
REGISTERED ENGINEER	REGISTERED ENGINEER

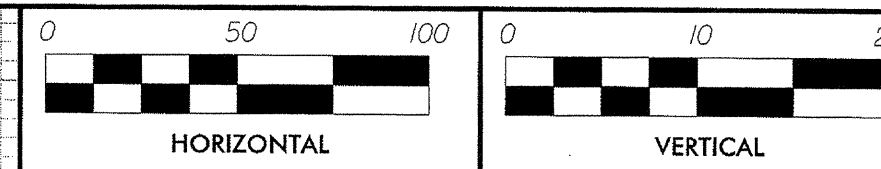

PI = 19+40.00
EL = 487.86'
VC = 650'
K = 92
DS = 50 MPH

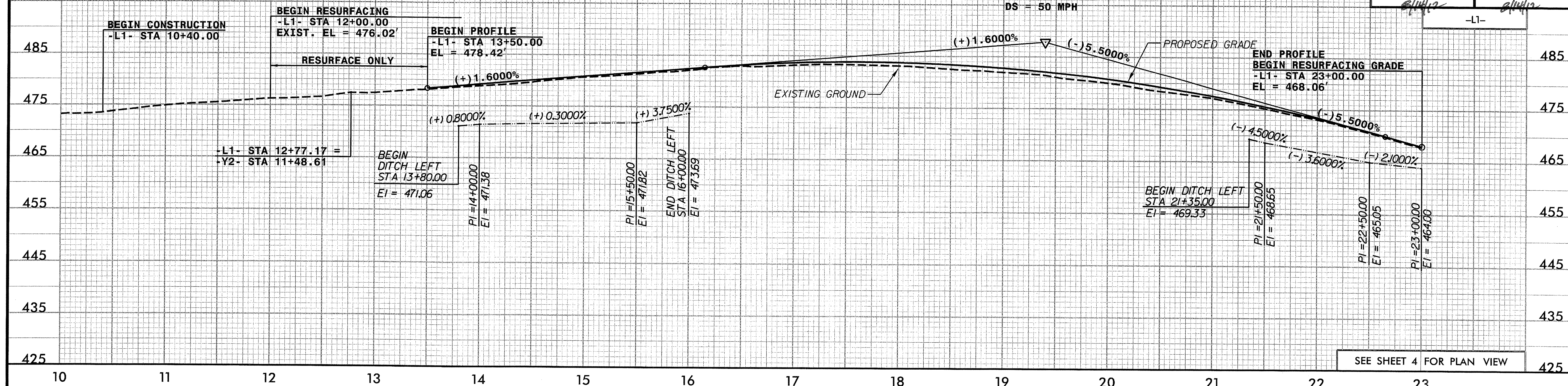

SEE SHEET 4 FOR PLAN VIEW

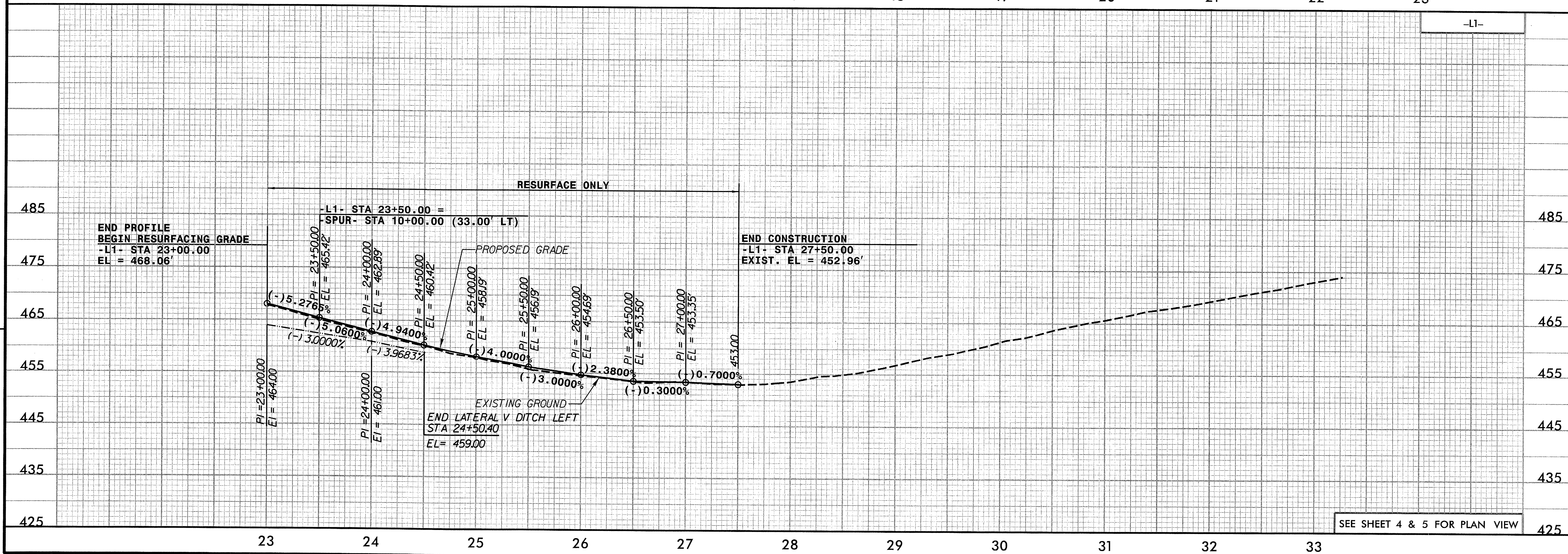

SEE SHEET 4 & 5 FOR PLAN VIEW

8/15/2012 G:\OR Projects\01050 - Hillsborough Street Bridge\Roadway\Proj\B4656_R0Y_06_PFL.dgn 11:03:33 AM

REVISIONS

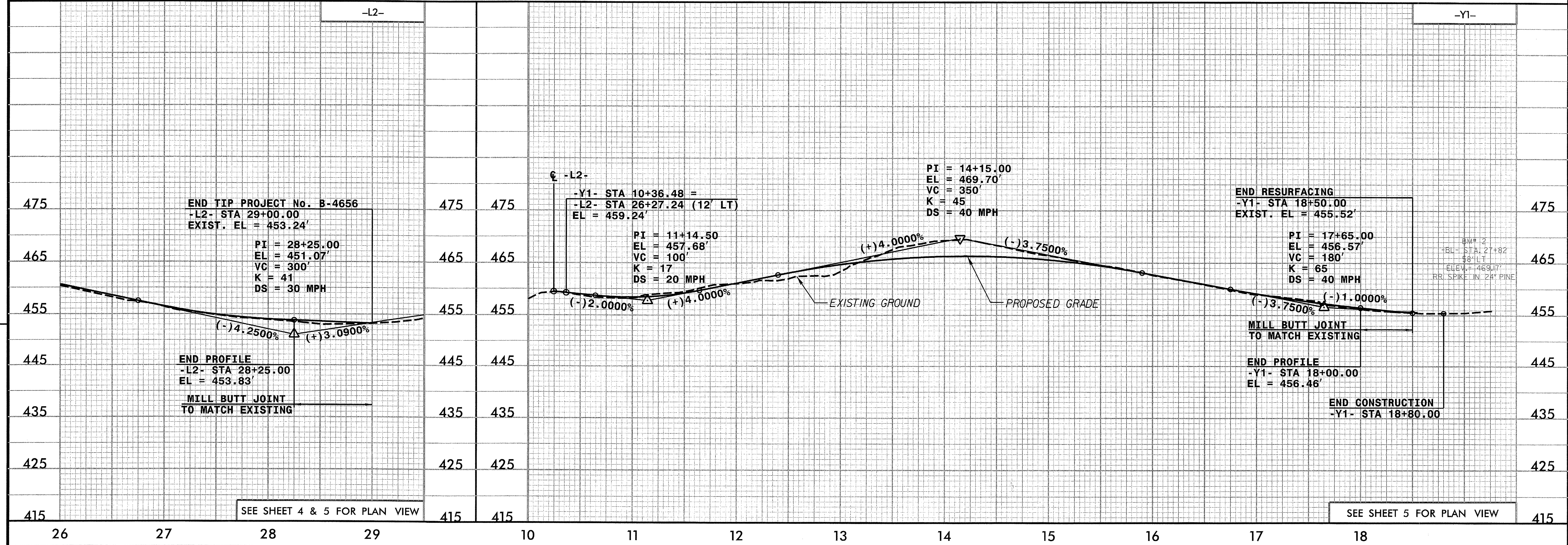
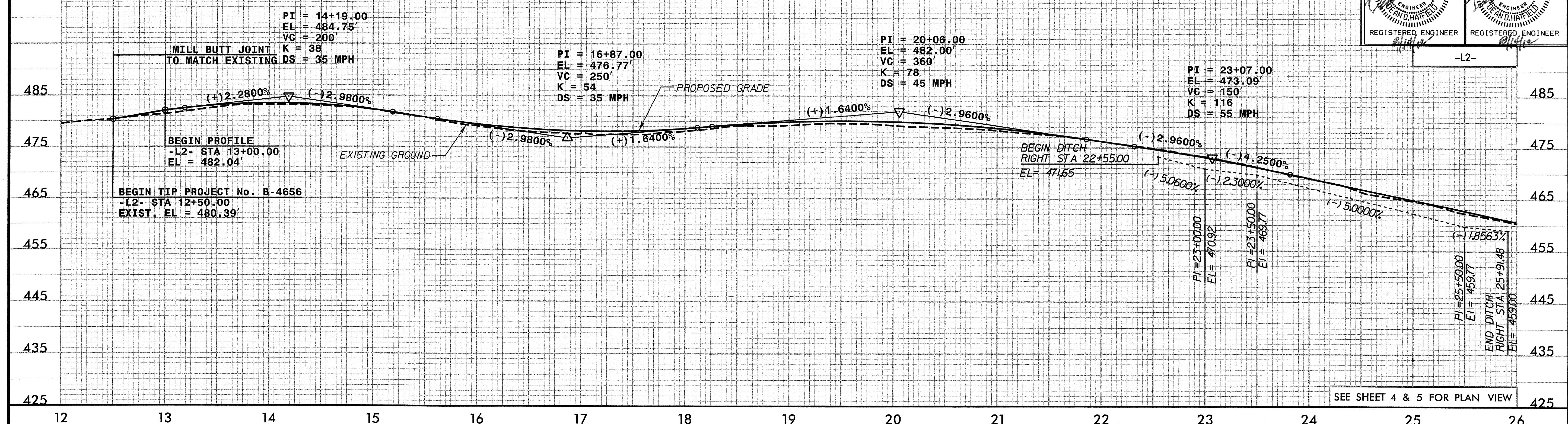
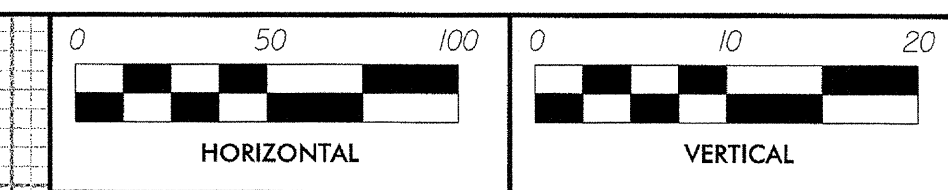

8/15/2012
 G:\DR Projects\DR1050 - Hillsborough Street Bridge\Roadway\Proj\B4656_R0Y_07_PFL.dgn
 11:03:34 AM

REVISIONS

SEE SHEET 4 & 5 FOR PLAN VIEW

SEE SHEET 5 FOR PLAN VIEW

8/15/2012
 G:\OR Projects\01050 - Hillsborough Street Bridge\Roadway\Proj\B4656_RDY_08_PFL.dgn
 11:03:35 AM

REVISIONS

THE LOUIS BERGER GROUP, Inc.
 1001 Wade Avenue, Suite 400
 Raleigh, North Carolina 27605

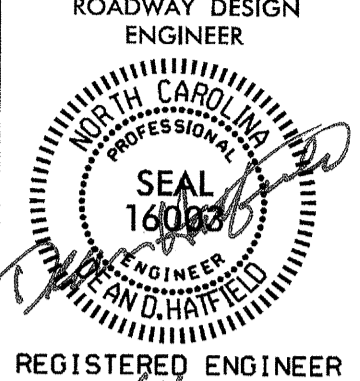
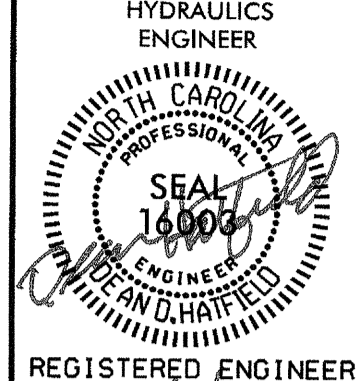
PROJECT REFERENCE NO. B-4656	SHEET NO. 8
RW SHEET NO.	
 ROADWAY DESIGN ENGINEER REGISTERED ENGINEER	 HYDRAULICS ENGINEER REGISTERED ENGINEER

