

**STATE OF NORTH CAROLINA  
DEPARTMENT OF TRANSPORTATION**

TIP NO. U-3810	SHEET NO. SIGN-1
APPROVED: <i>[Signature]</i>	
DATE: 7/17/12	
SEAL	

## SIGNING PLAN

### ONslow COUNTY

**LOCATION: SR 1406 (PINY GREEN ROAD) FROM US 17  
(MARINE BOULEVARD) TO NC 24 (FREEDOM WAY)**

**T.I.P.: U-3810**

**CONTRACT: C202887**

#### ROADWAY STANDARD DRAWING

THE FOLLOWING ROADWAY STANDARDS AS APPEAR IN "ROADWAY STANDARD DRAWINGS" - PROJECT SERVICES UNIT - N.C. DEPARTMENT OF TRANSPORTATION - RALEIGH, N.C., DATED JANUARY 2012 ARE APPLICABLE TO THIS PROJECT AND BY REFERENCE HEREBY ARE CONSIDERED A PART OF THESE PLANS:

STD. NO.	TITLE
903.10	GROUND MOUNTED SIGN SUPPORTS
904.10	ORIENTATION OF GROUND MOUNTED SIGNS
904.50	MOUNTING OF TYPE 'D', 'E' AND 'F' SIGNS ON 'U' CHANNEL POSTS

#### GENERAL NOTES

- . SIGNS FURNISHED BY STATE
- . IF REMOVAL OR RELOCATION OF SIGNS ON PRIVATE STREET (NON-STATE MAINTAINED) IS REQUIRED DUE TO CONSTRUCTION, THE CONTRACTOR SHALL INFORM THE ENGINEER. THE WORK WILL BE COMPLETED BY OTHERS.
- . WHEN NOT STATIONED OR DIMENSIONED ON PLANS, ALL 'E' AND 'F' SIGNS SHALL BE FIELD LOCATED BY THE ENGINEER
- . ALL EXISTING SIGNS ON "U" CHANNEL POST WITHIN THE PROJECT LIMITS SHALL BE REMOVED AND DISPOSED OF UNLESS OTHERWISE NOTED ON PLANS.
- . WHEN EXISTING SIGNS ARE REMOVED AND INSTALLED ON NEW SUPPORTS, THE RE-ERECTION SHALL IMMEDIATELY FOLLOW THE REMOVAL.
- . THE BACKGROUND FOR TYPE E & F SIGNS SHALL BE TYPE C REFLECTIVE SHEETING.
- . SEE ROADWAY PLANS FOR GUARD/GUIDE RAIL DETAILS.

#### SUMMARY OF QUANTITIES

ITEM NO.		ITEM DESCRIPTION	QUANTITY	UNIT
DESC. NO.	SECT. NO.			
4072000000	903	SUPPORTS, 3 LB STEEL U-CHANNEL	1095	L.F.
4096000000	904	SIGN ERECTION, TYPE D	4	EA.
4102000000	904	SIGN ERECTION, TYPE E	71	EA.
4108000000	904	SIGN ERECTION, TYPE F	8	EA.
4155000000	907	DISPOSAL OF SIGN SYSTEM, U-CHANNEL	68	EA.

#### INDEX

SHEET NO.	DESCRIPTION
SIGN - 1	TITLE SHEET - SUMMARY OF QUANTITIES, ROADWAY STANDARD DRAWINGS, INDEX, & NOTES
SIGN - 2	TYPE "E" SIGNS
SIGN - 2A	TYPE "D" SIGNS
SIGN - 3	TYPE "F" SIGNS
SIGN - 4-17	EXISTING & PROPOSED SIGNS

#### PROJECT NOTE

- 1 DISPOSAL OF SIGN SYSTEM, U-CHANNEL

PLAN PREPARED BY: N.C.D.O.T. SIGNING AND DELINEATION UNIT

AYMAN I. ALQUDWAH P.E. SIGNING & DELINEATION REGIONAL ENGINEER  
BARRY NOWLIN SIGNING & DELINEATION PROJECT DESIGN TECHNICIAN

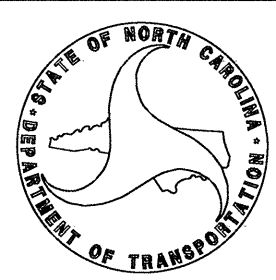

TIP NO. U-3810	SHEET NO. SIGN-2
APPROVED: <i>[Signature]</i>	
DATE: 7/17/12	
SEAL	
	

401 QUANTITY REQ'D 26

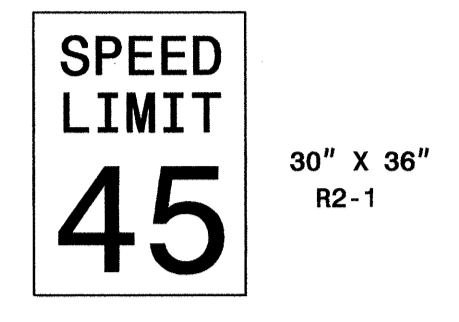

ONE "U" POST PER SIGN

406 QUANTITY REQ'D 2

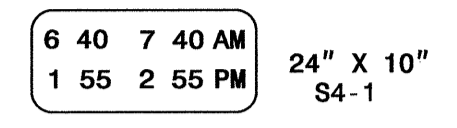

MOUNT BELOW SIGN 407  
IN 2 INSTALLATIONS

411 QUANTITY REQ'D 3



TWO "U" POSTS PER SIGN

418 QUANTITY REQ'D 13

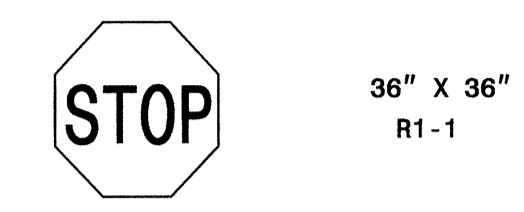

ONE "U" POST PER SIGN

402 QUANTITY REQ'D 2

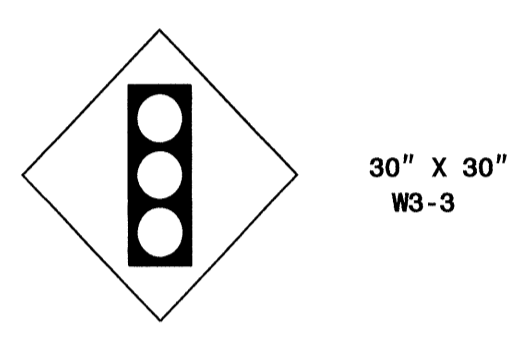

ONE "U" POST PER SIGN

407 QUANTITY REQ'D 2

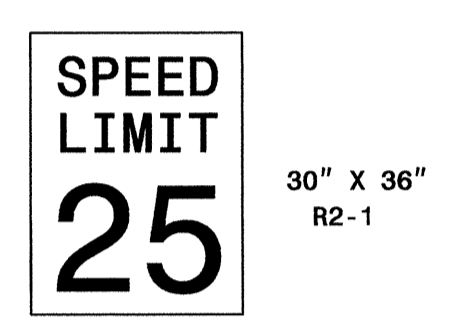

ONE "U" POST PER SIGN

412 QUANTITY REQ'D 1



TWO "U" POSTS PER SIGN

419 QUANTITY REQ'D 2

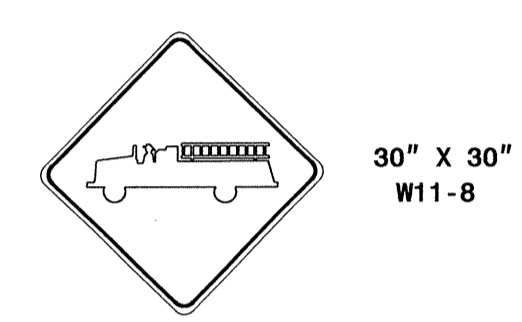

ONE "U" POST PER SIGN

403 QUANTITY REQ'D 2

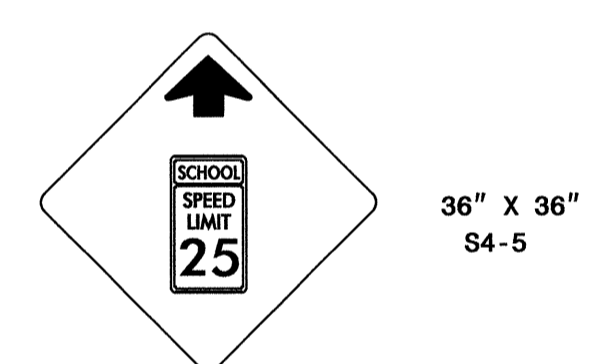

YELLOW/GREEN REFLECTIVE SHEETING  
TWO "U" POSTS PER SIGN

408 QUANTITY REQ'D 4



MOUNT ABOVE SIGN 407  
IN 2 INSTALLATIONS  
MOUNT BELOW SIGN 405  
IN 2 INSTALLATIONS

413 QUANTITY REQ'D 2



ONE "U" POST PER SIGN

420 QUANTITY REQ'D 2

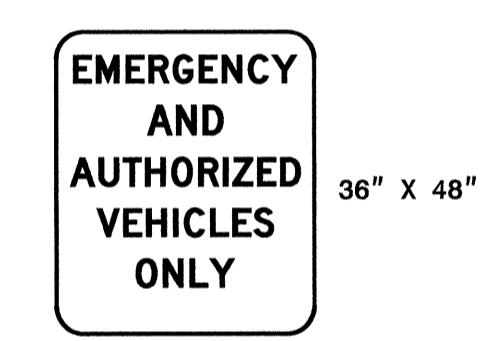

ONE "U" POST PER SIGN

404 QUANTITY REQ'D 2

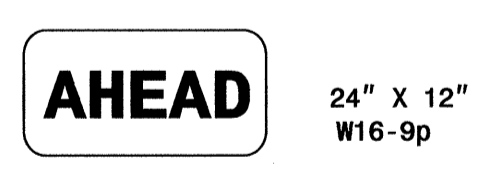

MOUNT BELOW SIGN 405  
IN 2 INSTALLATIONS

409 QUANTITY REQ'D 2

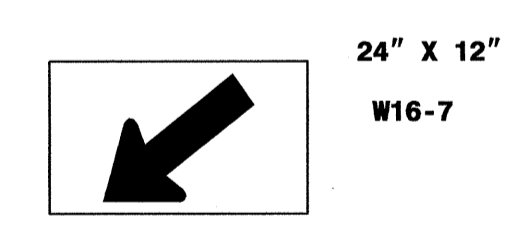

YELLOW/GREEN REFLECTIVE SHEETING  
MOUNT BELOW SIGN 405  
IN 2 INSTALLATIONS

416 QUANTITY REQ'D 2

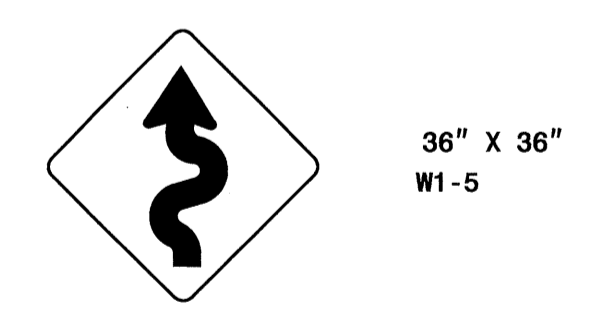

ONE "U" POSTS PER SIGN

405 QUANTITY REQ'D 6



YELLOW/GREEN REFLECTIVE SHEETING  
ONE "U" POSTS PER SIGN

410 QUANTITY REQ'D 1

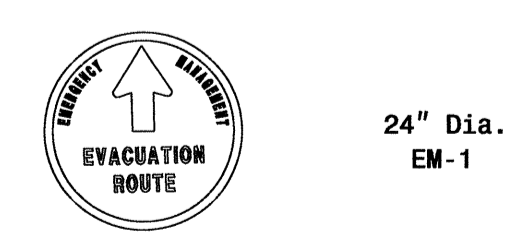

MOUNT BELOW SIGN 508

417 QUANTITY REQ'D 1



MOUNT ABOVE SIGN 304  
IN 1 INSTALLATION  
MOUNT BELOW SIGN 302  
IN 1 INSTALLATION

**TYPE "E" SIGNS**

I:\JUL-2012\_09:06  
 R:\Traffic Signs\ADD\Quantities & GM Signs\U-3810\_Engseed.dgn  
 AT 9:27:51  
 bnowlin

TIP NO. U-3810	SHEET NO. SIGN-2A
APPROVED: <i>[Signature]</i>	
DATE: 6/7/12	
SEAL	



SIGN NUMBER: 301      BACKG COLOR: Green  
TYPE: D      COPY COLOR: White      DESIGN BY: B.N.      CHECKED BY:      DATE: Jun 07, 2012  
PROJECT ID: U-3810      DIV: 03

QUANTITY: 1

SYMBOL	X	Y	WID	HT
AR_Type D	76.1	14	8	12

SIGN WIDTH: 8'-0"  
HEIGHT: 3'-0"  
TOTAL AREA: 24.0 Sq.Ft.

BORDER TYPE: FLUSH  
RECESS: 0"  
WIDTH: 1"  
RADII: 6"

MAT'L: 0.125" (3.2 mm) ALUMINUM

NO. Z BARS:  
LENGTH:

USE NOTES: 1,2

1. Legend and border(except those that are colored black) shall be direct applied Grade C sheeting.  
2. Background shall be Grade C reflective sheeting.

BORDER R=6" TH=1"

Spacing Factor is 1 unless specified otherwise

LETTER POSITIONS

Letter spacings are to start of next letter													Series/Size
													Text Length
7.9	8.2	6.2	2.2	3.8	4.7	8	6.9	6.1	5.1	37			D 2000
													51.1
													D 2000
7.9	7.2	2.6	6.4	4.7	8	6.3	5.8	5.9	5.8	6.2	1.3	27.9	60.2

FILENAME: U-3810\_Sgn\_SGN\_detour      NORTH CAROLINA D.O.T. SIGN DETAIL

SIGN NUMBER: 302      BACKG COLOR: Green  
TYPE: D      COPY COLOR: White      DESIGN BY: B.N.      CHECKED BY:      DATE: Jun 07, 2012  
PROJECT ID: U-3810      DIV: 03

QUANTITY: 1

SYMBOL	X	Y	WID	HT
AR_Type D				

SIGN WIDTH: 6'-6"  
HEIGHT: 2'-6"  
TOTAL AREA: 16.3 Sq.Ft.

BORDER TYPE: FLUSH  
RECESS: 0"  
WIDTH: 1"  
RADII: 3"

MAT'L: 0.125" (3.2 mm) ALUMINUM

NO. Z BARS:  
LENGTH:

USE NOTES: 1,2

1. Legend and border(except those that are colored black) shall be direct applied Grade C sheeting.  
2. Background shall be Grade C reflective sheeting.

BORDER R=3" TH=1"

Spacing Factor is 1 unless specified otherwise

LETTER POSITIONS

Letter spacings are to start of next letter													Series/Size	
													Text Length	
9.2	6.5	5.8	5.8	5.6	4.5	6.2	5.6	6.6	2.9	2.9	2.6	4.7	9.2	D 2000
													59.5	
														D 2000
20.1	5.3	1.6	2.6	4.5	6	4.5	2.2	7.1	1.6	2.4	20.1			37.7

FILENAME: U-3810\_Sgn\_SGN\_detour      NORTH CAROLINA D.O.T. SIGN DETAIL

SIGN NUMBER: 303      BACKG COLOR: Green  
TYPE: D      COPY COLOR: White      DESIGN BY: B.N.      CHECKED BY:      DATE: Jun 07, 2012  
PROJECT ID: U-3810      DIV: 03

QUANTITY: 1

SYMBOL	X	Y	WID	HT
AR_Type D	82	14.1	8	12

SIGN WIDTH: 8'-6"  
HEIGHT: 3'-0"  
TOTAL AREA: 25.5 Sq.Ft.

BORDER TYPE: FLUSH  
RECESS: 0"  
WIDTH: 1"  
RADII: 6"

MAT'L: 0.125" (3.2 mm) ALUMINUM

NO. Z BARS:  
LENGTH:

USE NOTES: 1,2

1. Legend and border(except those that are colored black) shall be direct applied Grade C sheeting.  
2. Background shall be Grade C reflective sheeting.

BORDER R=6" TH=1"

Spacing Factor is 1 unless specified otherwise

LETTER POSITIONS

Letter spacings are to start of next letter													Series/Size		
													Text Length		
8	7.1	6.3	5.5	3.8	5.8	3.5	3.8	8	7	3.7	5.5	5.8	5.1	23	D 2000
													71		
															D 2000
27.6	6.3	5.8	5.9	5.8	6.2	1.3	42.9							31.3	

FILENAME: U-3810\_Sgn\_SGN\_detour      NORTH CAROLINA D.O.T. SIGN DETAIL

SIGN NUMBER: 304      BACKG COLOR: Green  
TYPE: D      COPY COLOR: White      DESIGN BY: B.N.      CHECKED BY:      DATE: Jun 07, 2012  
PROJECT ID: U-3810      DIV: 03

QUANTITY: 1

SYMBOL	X	Y	WID	HT
AR_Type D				

SIGN WIDTH: 3'-0"  
HEIGHT: 1'-6"  
TOTAL AREA: 4.5 Sq.Ft.

BORDER TYPE: FLUSH  
RECESS: 0"  
WIDTH: 0.5"  
RADII: 2"

MAT'L: 0.125" (3.2 mm) ALUMINUM

NO. Z BARS:  
LENGTH:

USE NOTES: 1,2

1. Legend and border(except those that are colored black) shall be direct applied Grade C sheeting.  
2. Background shall be Grade C reflective sheeting.

BORDER R=2" TH=0.5"

Spacing Factor is 1 unless specified otherwise

LETTER POSITIONS

Letter spacings are to start of next letter													Series/Size	
													Text Length	
12	4.4	2.4	2.6	2.6	12									EM 2000
													12	
														EM 2000
1.4	4.1	4.2	3.9	3.5	3.4	3.9	4.2	2.5	3.4	1.4				33.1

FILENAME: U-3810\_Sgn\_SGN\_detour      NORTH CAROLINA D.O.T. SIGN DETAIL

TYPE "D" SIGNS

Q7-JUN-2012 16:27  
 R:\Projects\3810\3810\_Sign\_Designs\U-3810\_Sgn\_SGN\_detour.dgn  
 brooklyn AL TEL277319

APPROVED: *James H. ...*  
DATE: 6/7/12



501

**NORTH** 1-24 X 12

**17** 1-24 X 24

ONE "U" POSTS PER SIGN

506

**SOUTH** 1-24 X 12

**17** 1-24 X 24

ONE "U" POSTS PER SIGN

502

**SOUTH NORTH** 2-24 X 12

**17 17** 2-24 X 24

**← →** 2-21 X 15

TWO "U" POSTS PER SIGN

507

**EAST** 1-24 X 12

**24** 1-24 X 24

ONE "U" POSTS PER SIGN

503

**JCT** 1-24 X 12

**17** 1-24 X 24

ONE "U" POSTS PER SIGN

508

**WEST** 1-24 X 12

**24** 1-24 X 24

ONE "U" POSTS PER SIGN

504

**EAST WEST** 2-24 X 12

**24 24** 2-24 X 24

**← →** 2-21 X 15

TWO "U" POSTS PER SIGN

505

**JCT** 1-24 X 12

**24** 1-24 X 24

ONE "U" POSTS PER SIGN

**TYPE "F" SIGNS**

05 JUN 2012 16:09 C:\CADD\Quantities & GM Signs\U-3810.Engseed.dgn

TIP NO. U-3810	SHEET NO. SIGN-4
APPROVED: <i>[Signature]</i>	
DATE: 6/7/12	
SEAL	

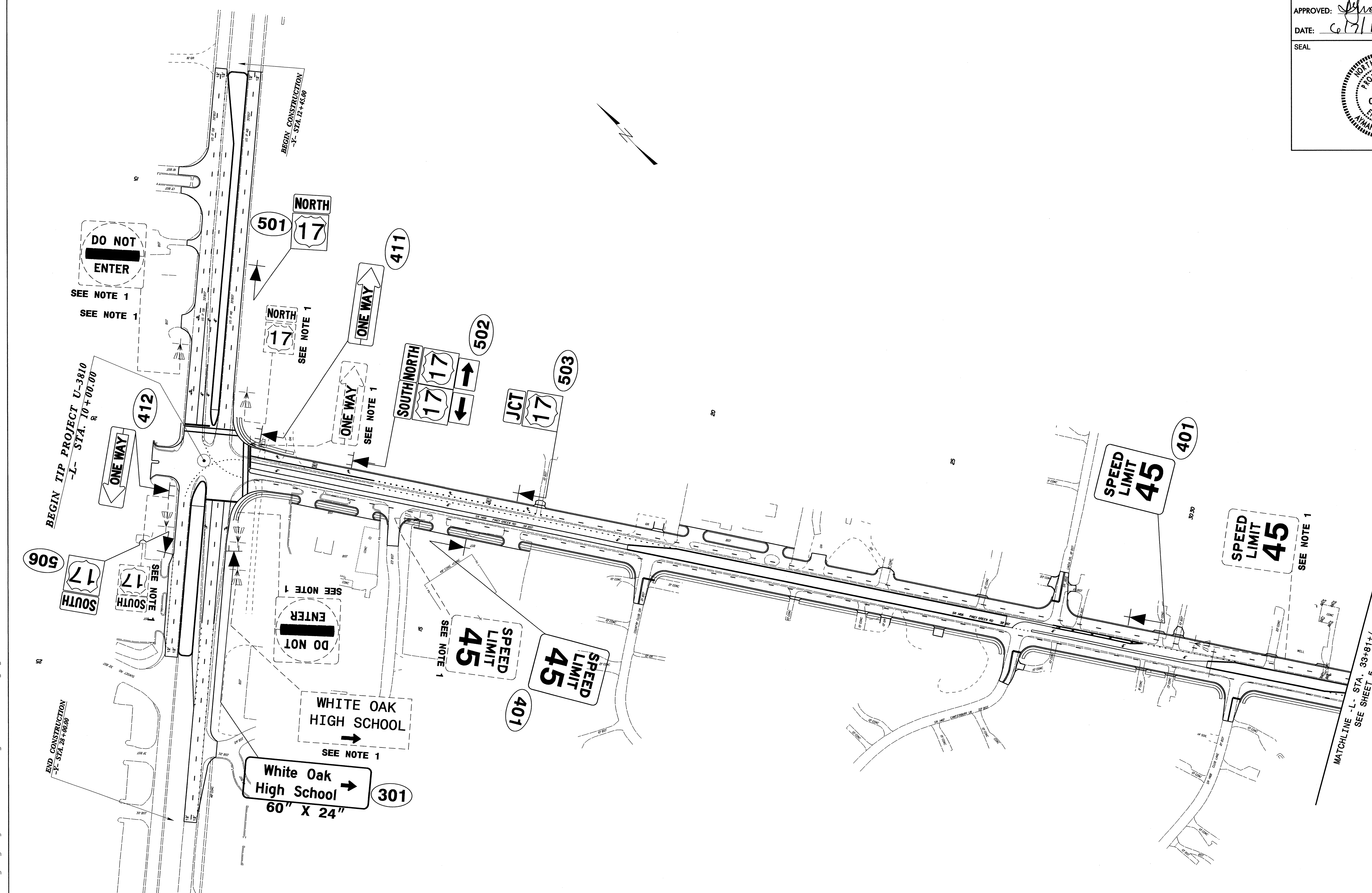

**EXISTING & PROPOSED SIGNS**  
-L- STA. 10+00+/- TO 33+81+/-

07 JUN 2012 14:40  
 C:\CADD\Signing Layout Plans\U-3810.Sgn.5GN.4.existing.dgn  
 broun

TIP NO. U-3810	SHEET NO. SIGN-5
APPROVED: <i>Alfred Hendrick</i>	
DATE: 6/7/12	
SEAL	

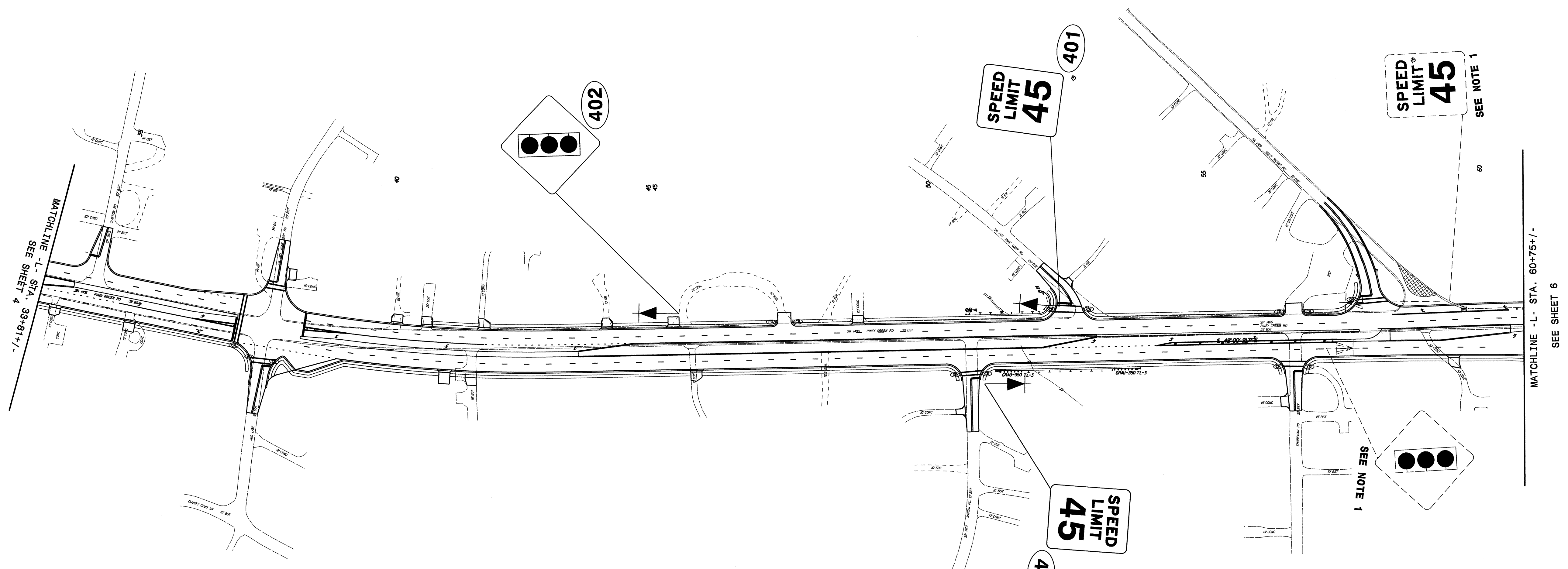

**EXISTING & PROPOSED SIGNS**  
 -L- STA. 33+81+/- TO 60+75+/-

07 JUN 2012 11:06  
 P:\Projects\2012\Signing Layout Plans\U-3810\_Sgn\_SGN\_5\_existing.dgn  
 A:\browlin

TIP NO. U-3810	SHEET NO. SIGN-6
APPROVED: <i>[Signature]</i>	
DATE: 6/11/12	
SEAL	

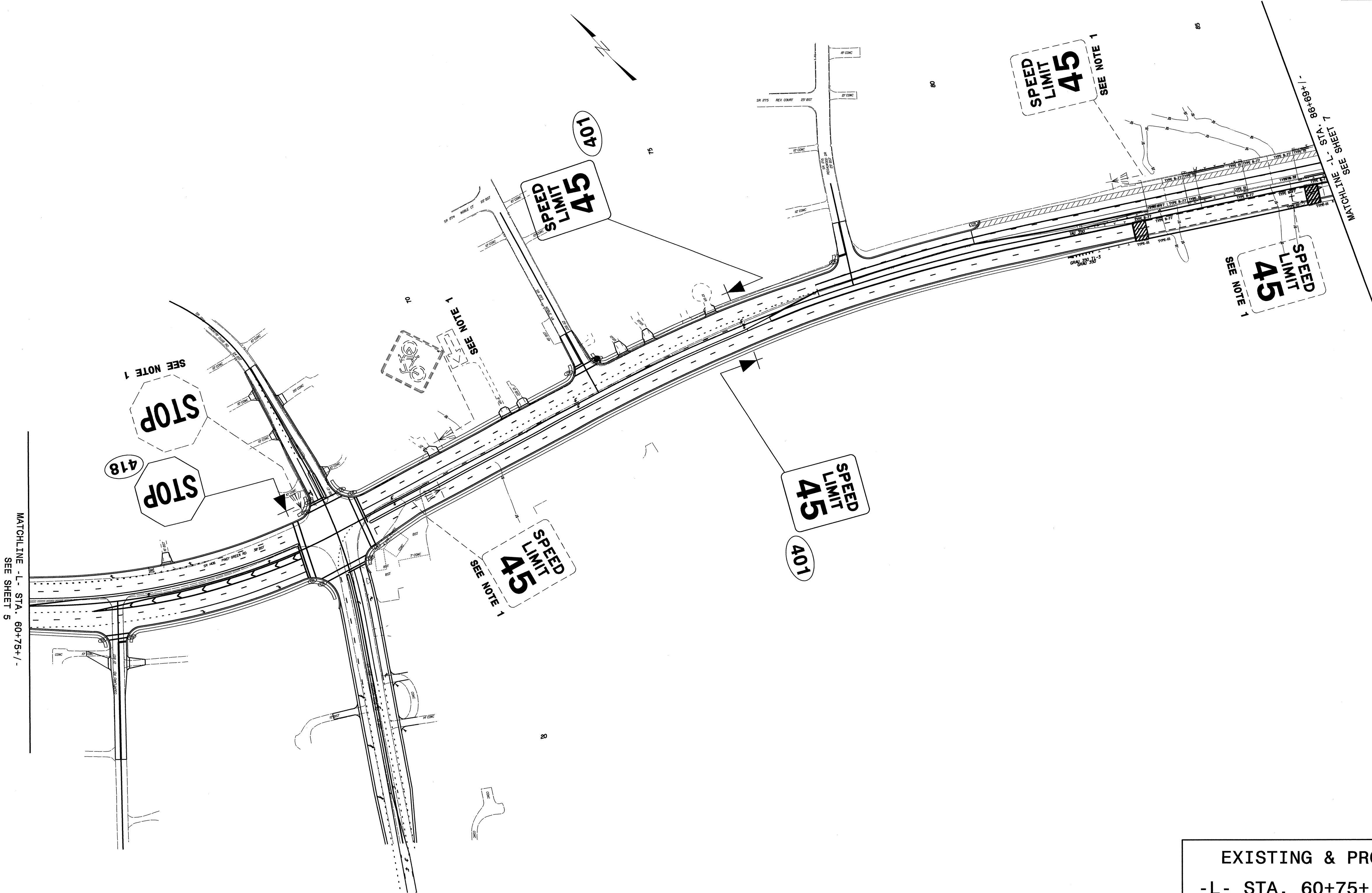

**EXISTING & PROPOSED SIGNS**  
 -L- STA. 60+75+/- TO 86+69+/-

07 JUN 2012 15:07  
 C:\Users\p11111\Documents\Projects\U-3810\_Sgn\_SGN\_6\_existing.dgn  
 p11111  
 11/24/11

TIP NO. U-3810	SHEET NO. SIGN-7
APPROVED: <i>[Signature]</i>	
DATE: 6/2/12	
SEAL	

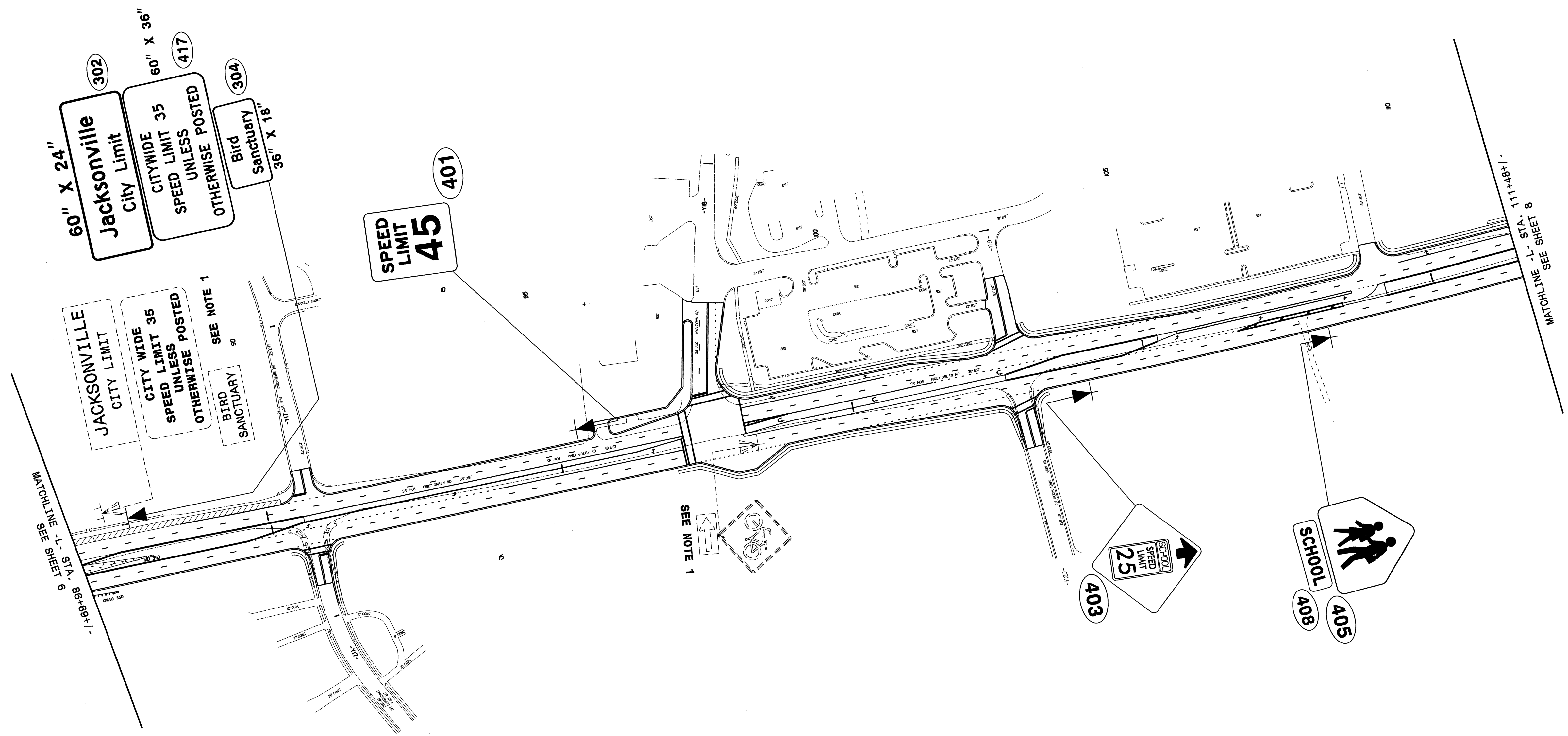
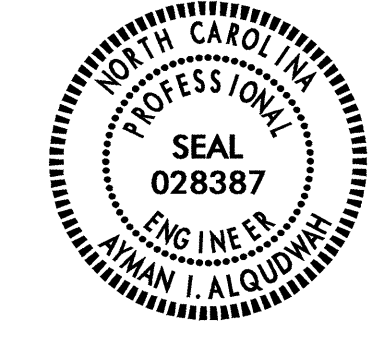

EXISTING & PROPOSED SIGNS  
 -L- STA. 86+69+/- TO 111+48+/-

07 JUN 2012 16:31  
 C:\Users\jbrown\Documents\CADD\Signing Layout Plans\U-3810-Sgn-SGN\_7\_existing.dgn  
 jbrown



TIP NO. U-3810	SHEET NO. SIGN-8
APPROVED: <i>[Signature]</i>	
DATE: 6/7/12	
SEAL	

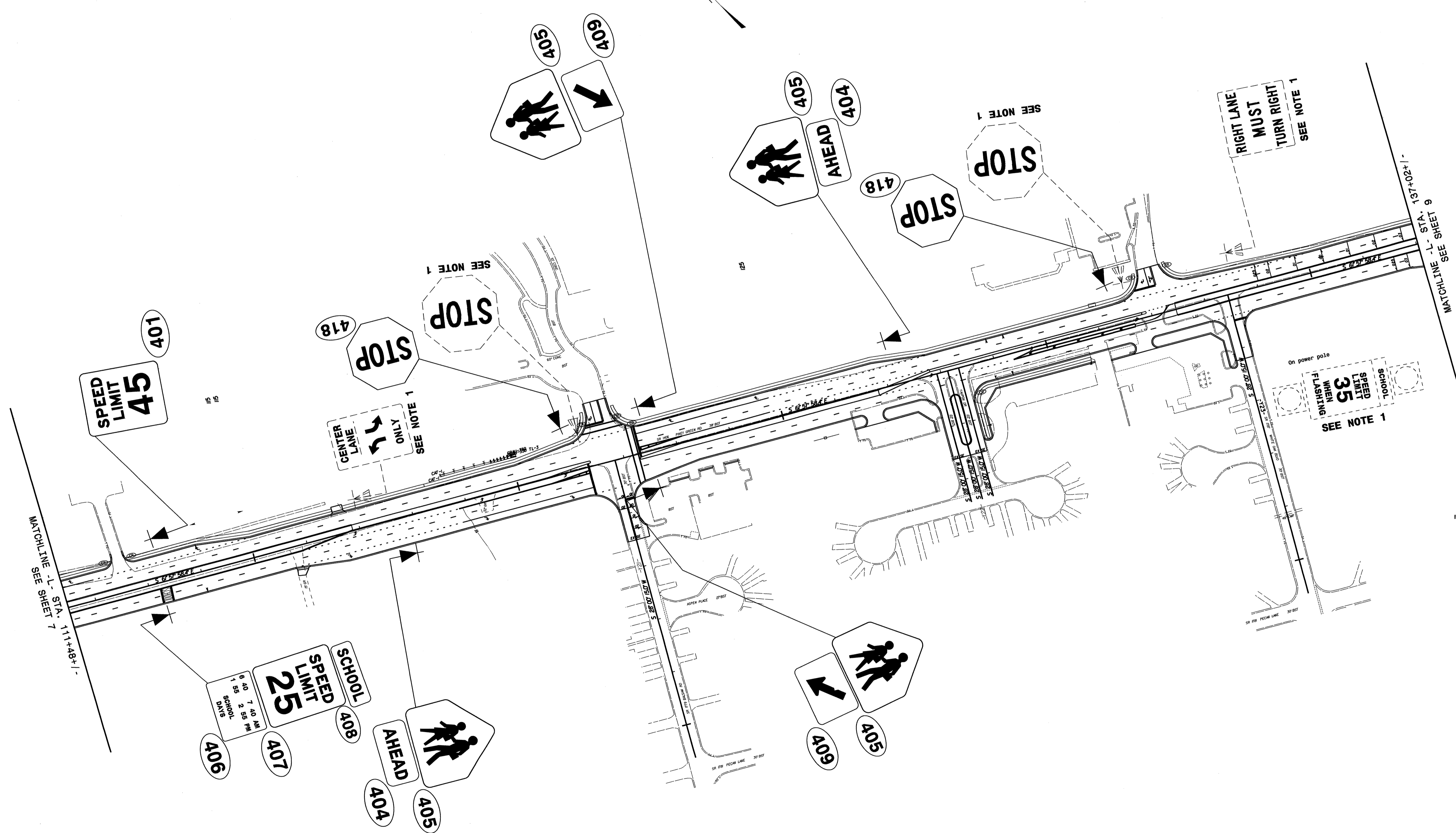

EXISTING & PROPOSED SIGNS  
-L- STA. 111+48+/- TO 137+02+/-

07 JUN 2012 15:08  
C:\Users\sgn\Documents\Projects\U-3810\Signs\Layout Plans\U-3810\_Sgn\_SGN\_8\_existing.dgn  
sgn  
brown

TIP NO. U-3810	SHEET NO. SIGN-9
APPROVED: <i>[Signature]</i>	
DATE: 6/7/12	
SEAL	

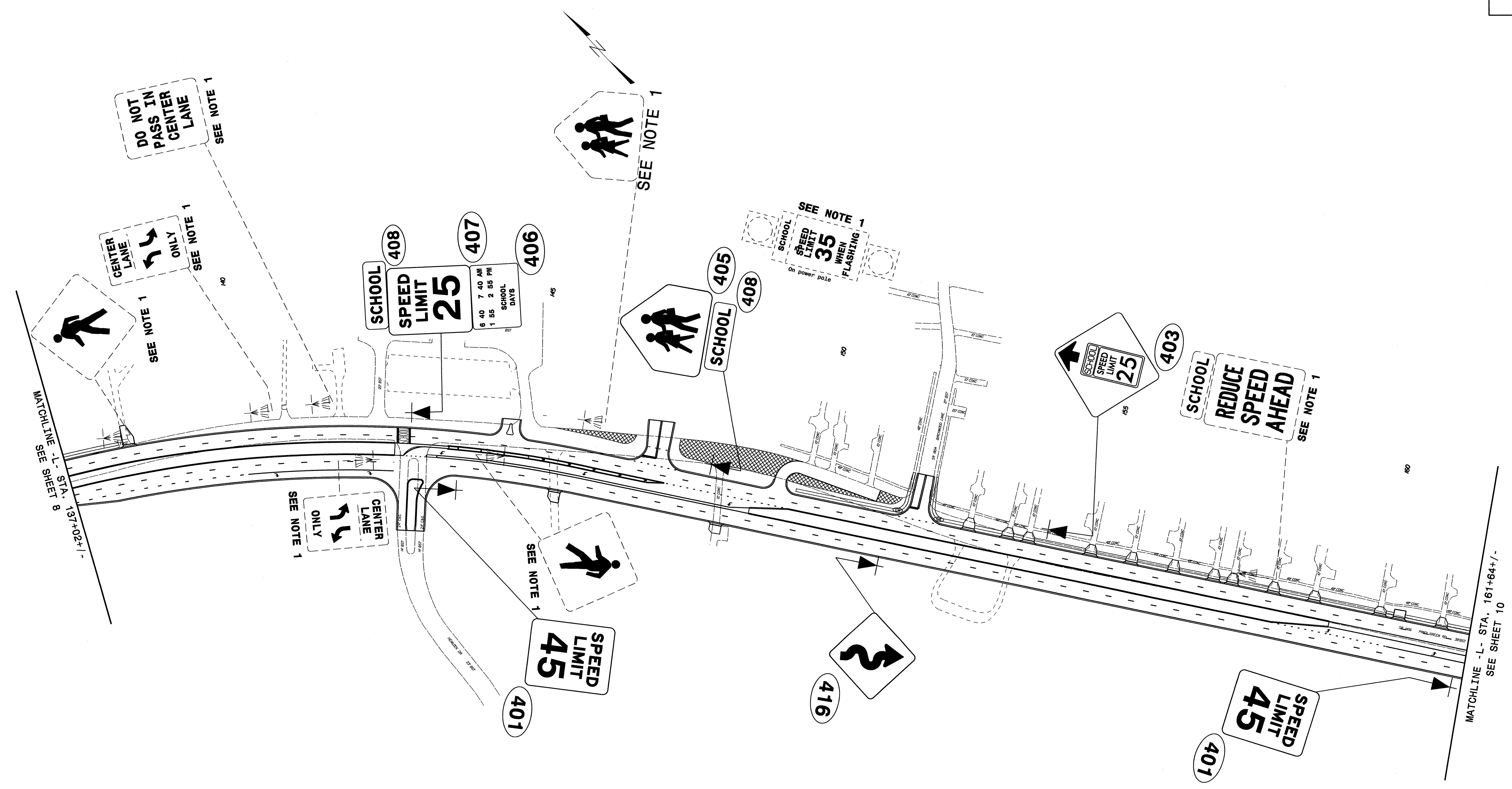

**EXISTING & PROPOSED SIGNS**  
 -L- STA. 137+02+/- TO 161+64+/-

07 JUN 2012 11:50  
 C:\Users\p101\Documents\CADD\Signing Layout Plans\U-3810\_Sgn\_SGN\_9\_existing.dgn  
 I. Aloudin  
 028387

TIP NO. U-3810	SHEET NO. SIGN-10
APPROVED: <i>[Signature]</i>	
DATE: 6/12	
SEAL	
	

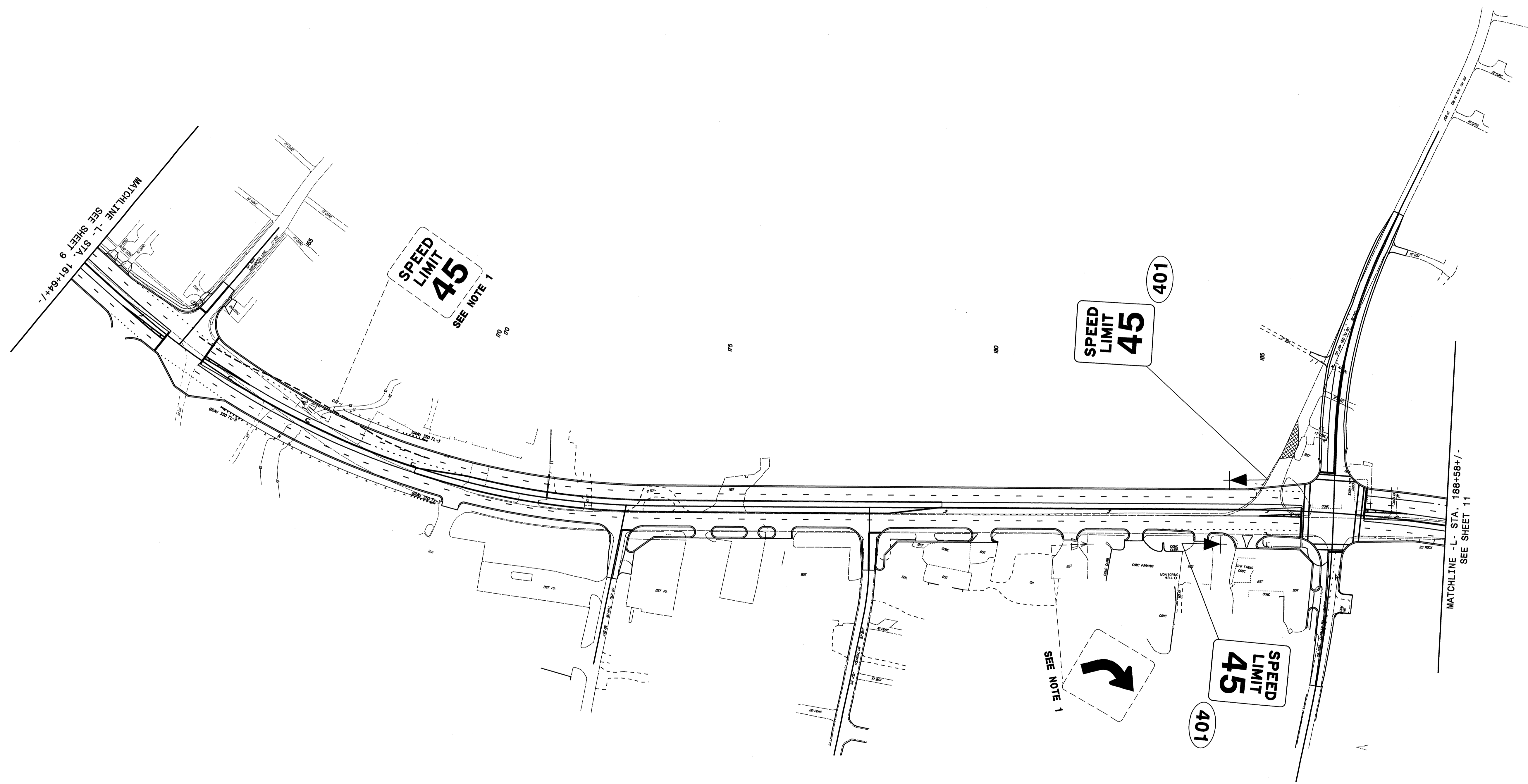

**EXISTING & PROPOSED SIGNS**  
-L- STA. 161+64+/- TO 188+58+/-

07 JUN 2012 11:40  
 C:\Users\jbrown\Documents\CAD\Signing Layout Plans\U-3810-Sgn-SCN-10-existing.dgn  
 jbrown

TIP NO. U-3810	SHEET NO. SIGN-11
APPROVED: <i>[Signature]</i>	
DATE: 6/7/12	
SEAL	
	

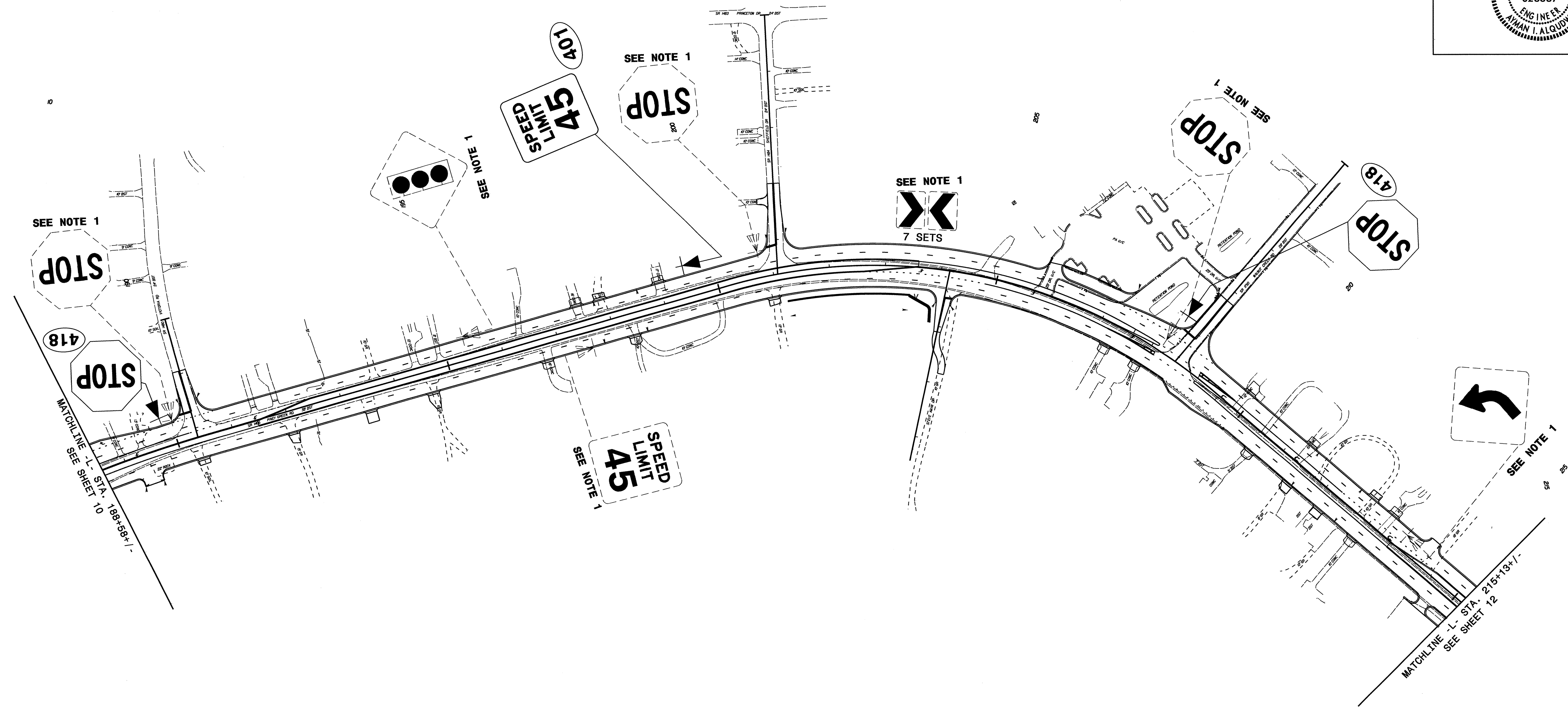

**EXISTING & PROPOSED SIGNS**  
 -L- STA. 188+58+/- TO 215+13+/-

07 JUN 2012 15:44  
 R:\TIP\3810\Signs\CADD\Staging Layout Plans\U-3810\_Sgn\_SGN\_11\_existing.dgn  
 At: 31E27615  
 browlin

TIP NO. U-3810	SHEET NO. SIGN-12
APPROVED: <i>[Signature]</i>	
DATE: 6/7/12	
SEAL	

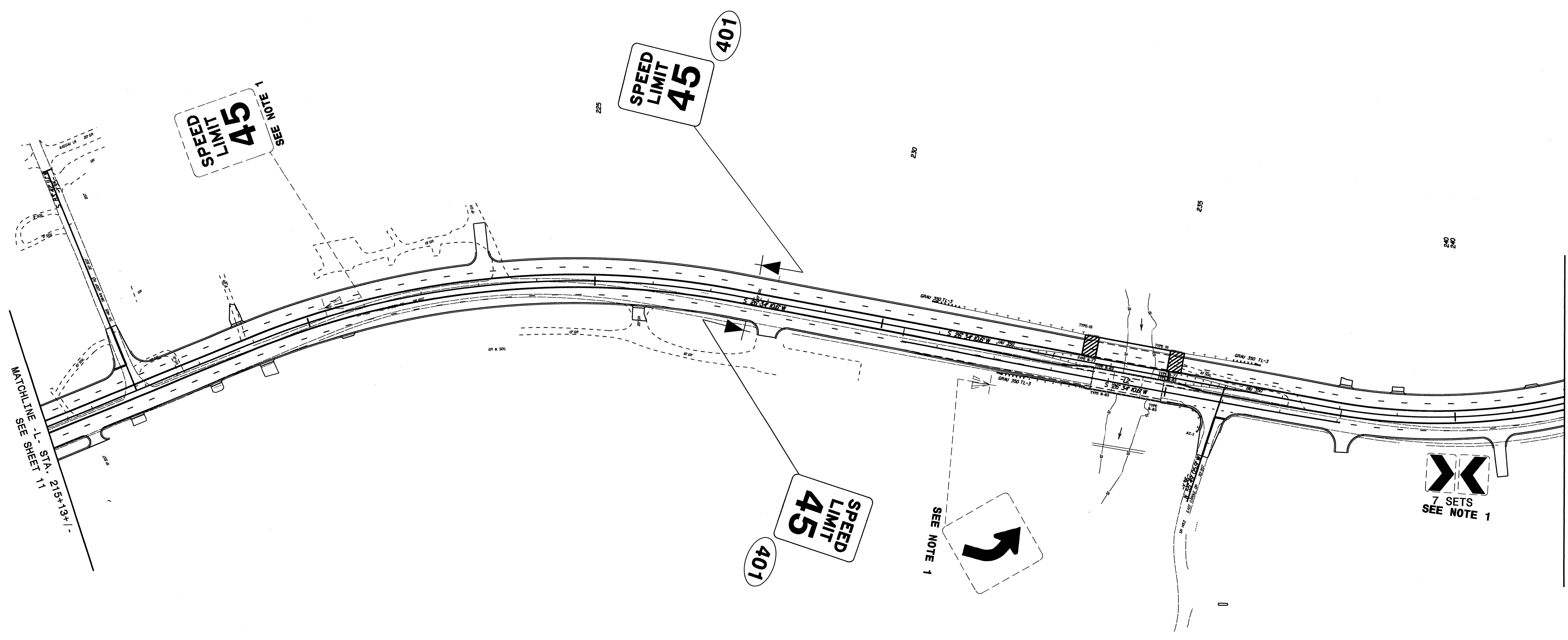

**EXISTING & PROPOSED SIGNS**  
 -L- STA. 215+13+/- TO 241+81+/-

07 JUN 2012 12:43  
 C:\Users\A1\Documents\Projects\U-3810\Signing Layout Plans\U-3810\_Sgn\_SGN-12\_existing.dgn  
 A1  
 browlin

TIP NO. U-3810	SHEET NO. SIGN-13
APPROVED: <i>Jayme Blaylock</i>	
DATE: 6/7/12	
SEAL	

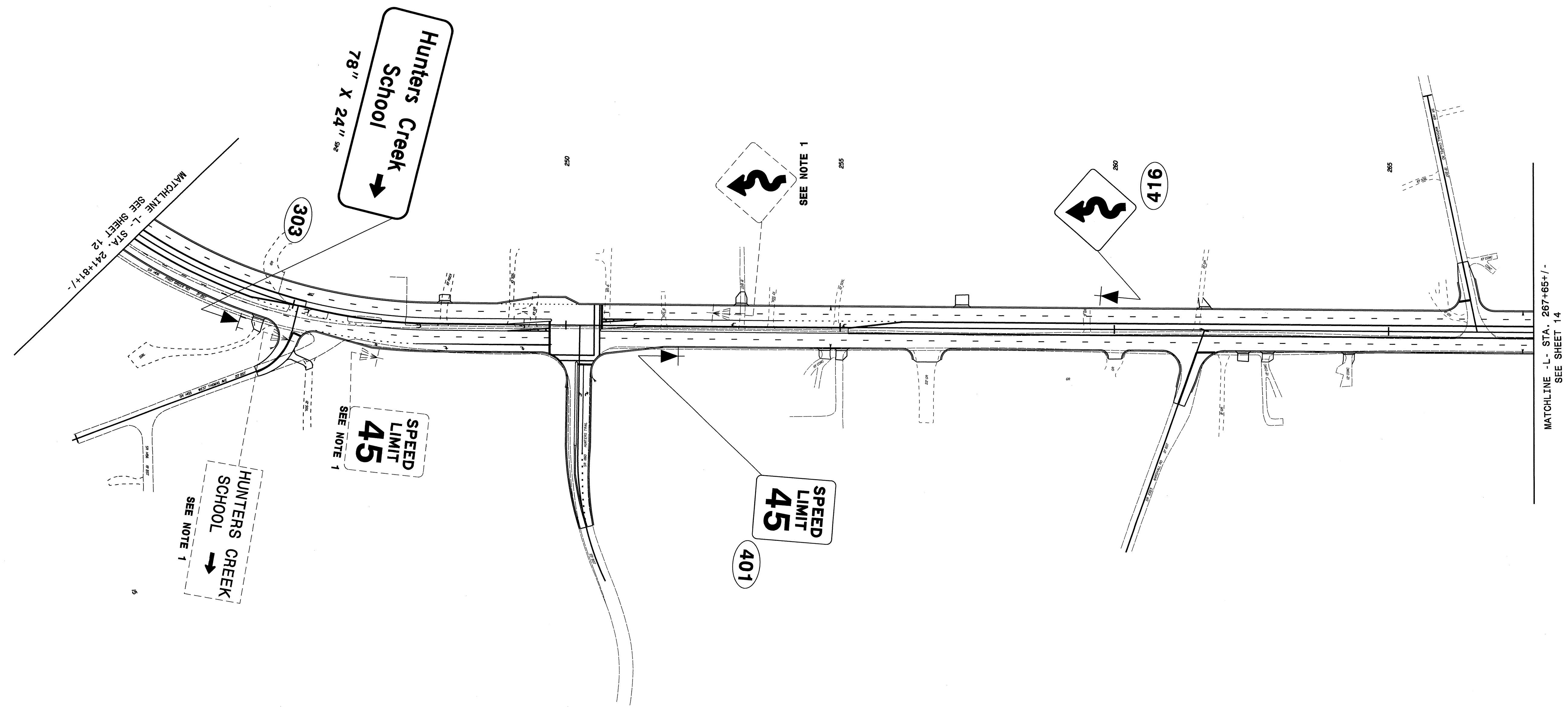

**EXISTING & PROPOSED SIGNS**  
-L-STA. 241+81+/- TO 267+65+/-

07 JUN 2012 12:45  
 C:\Users\jblaylock\Documents\CADD\Signing Layout Plans\U-3810.Sgn.SGN.13.existing.dgn  
 jblaylock

TIP NO. U-3810	SHEET NO. SIGN-14
APPROVED: <i>[Signature]</i>	
DATE: 6/7/12	
SEAL	

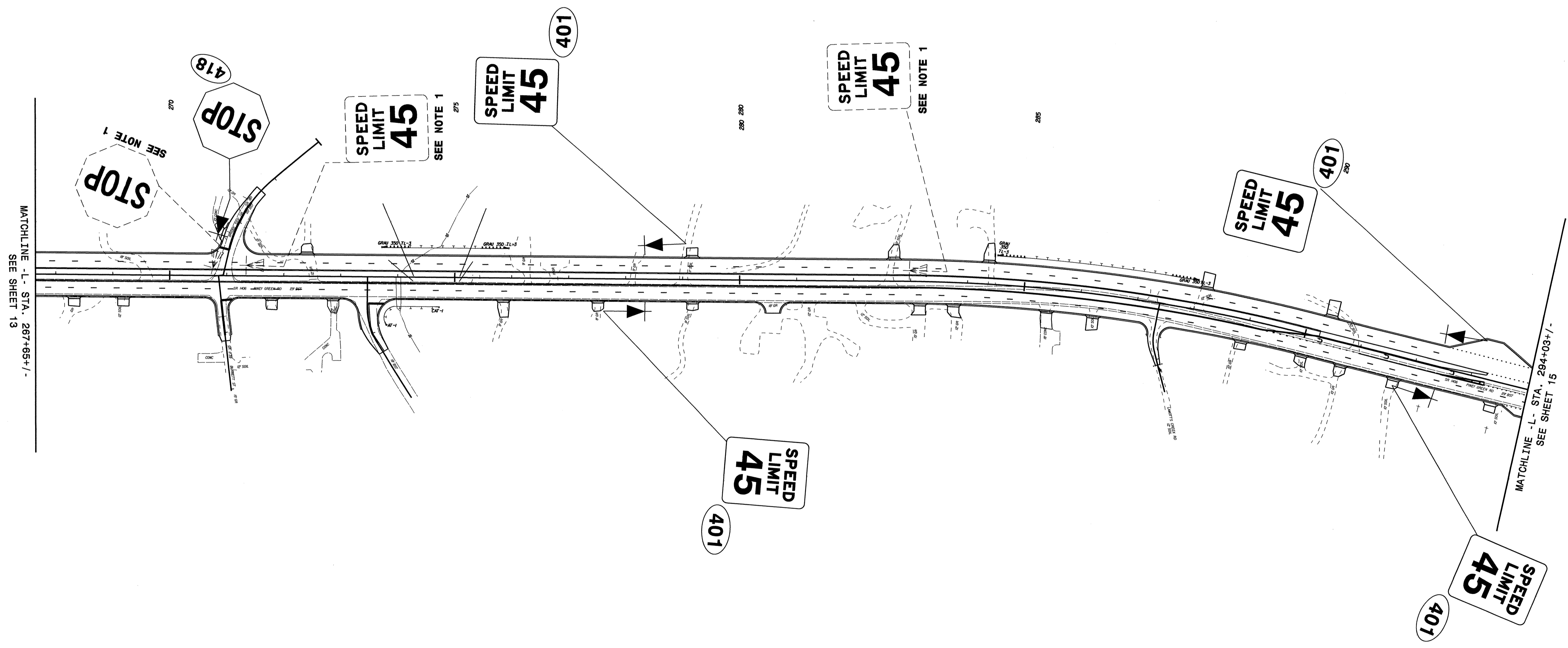

EXISTING & PROPOSED SIGNS  
 -L- STA. 267+65+/- TO 294+03+/-

07 JUN 2012 15:15  
 At: *[Signature]*  
 brown  
 CADD\Signing Layout Plans\U-3810.Sgn.SGN\_14-extsting.dgn

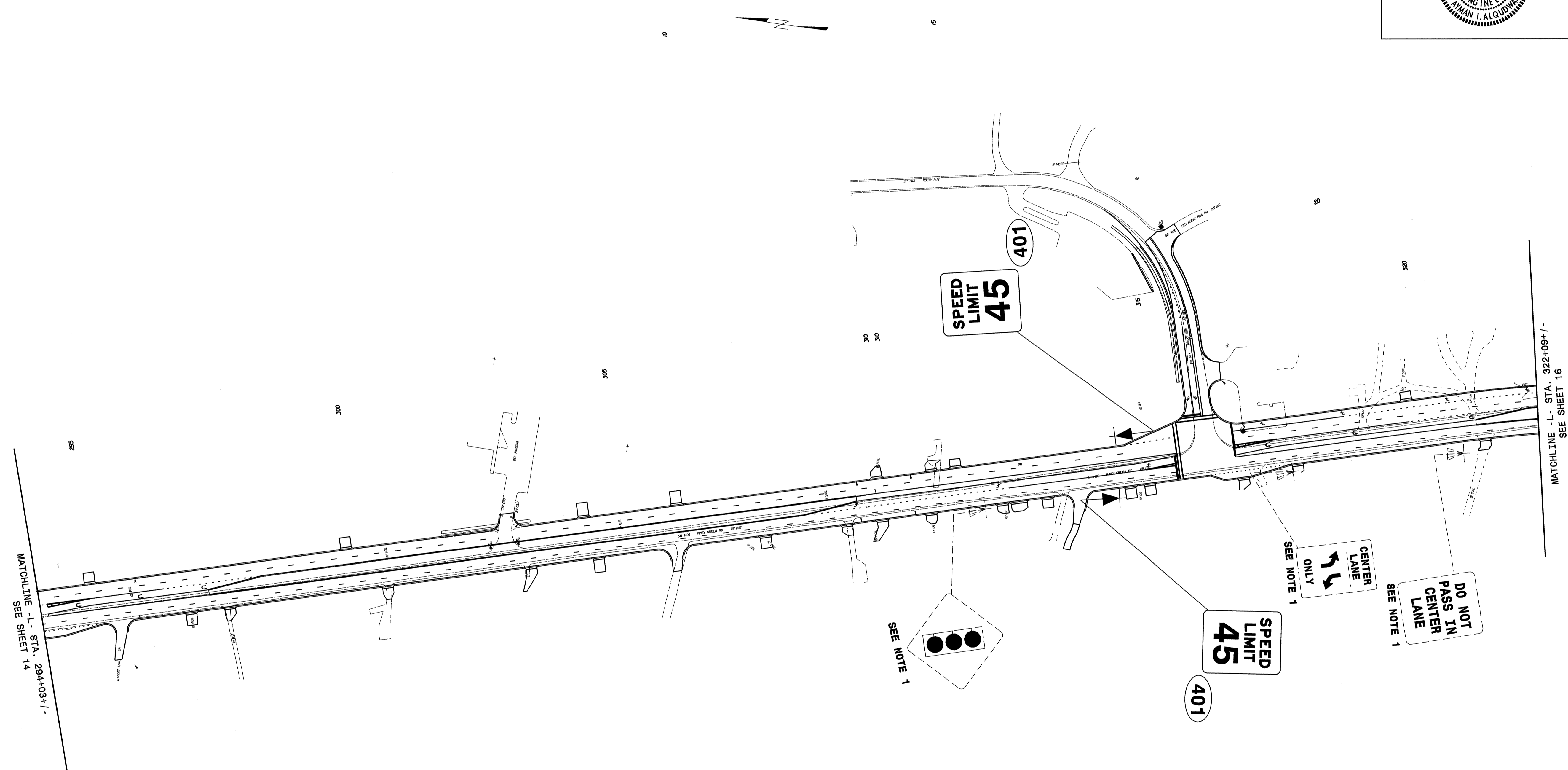

TIP NO. U-3810	SHEET NO. SIGN-15
APPROVED: <i>[Signature]</i>	
DATE: 6/7/12	
SEAL	



**EXISTING & PROPOSED SIGNS**  
 -L- STA. 294+03+/- TO 322+09+/-

07 JUN 2012 15:49  
 C:\Users\p103\Documents\CADD\Signing Layout Plans\U-3810.Sgn.SGN\_15-existing.dgn  
 20120607 15:49  
 brown

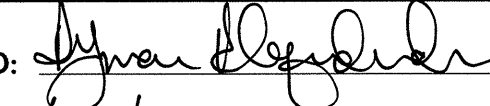

TIP NO. U-3810	SHEET NO. SIGN-16
APPROVED: 	
DATE: 7/12/12	
SEAL 	

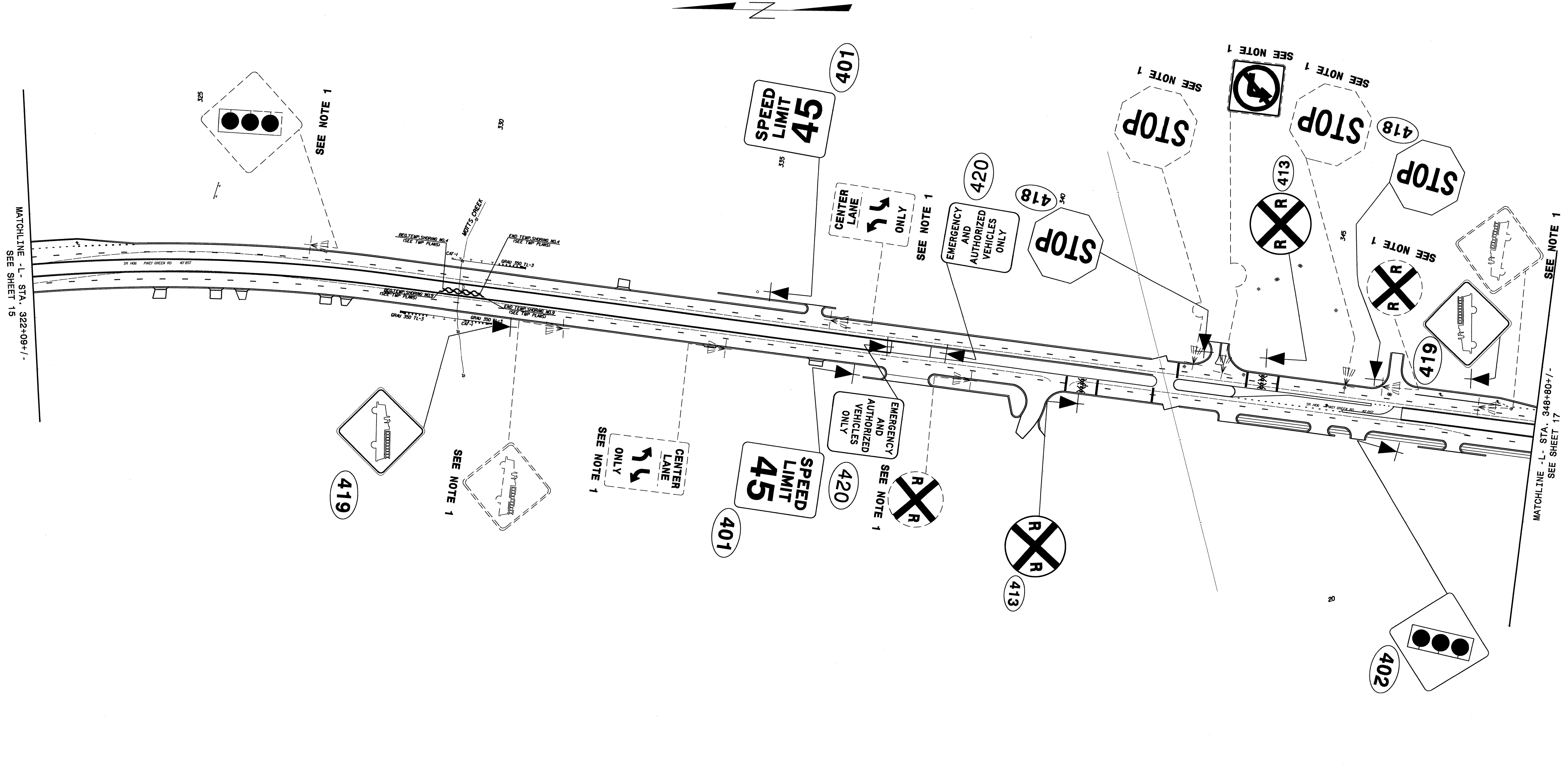

EXISTING & PROPOSED SIGNS  
 -L- STA. 322+09+/- TO 348+80+/-

\\pdp01\gsd\add\Staging\Layout\Plans\U-3810-Sgn-SGN-16.evs\drawing.dwg  
 Iwan I. Alqudwi  
 Professional Engineer  
 08/03/12 10:30:52 AM

TIP NO. U-3810	SHEET NO. SIGN-17
APPROVED: <i>[Signature]</i>	
DATE: 6/7/12	
SEAL	
	

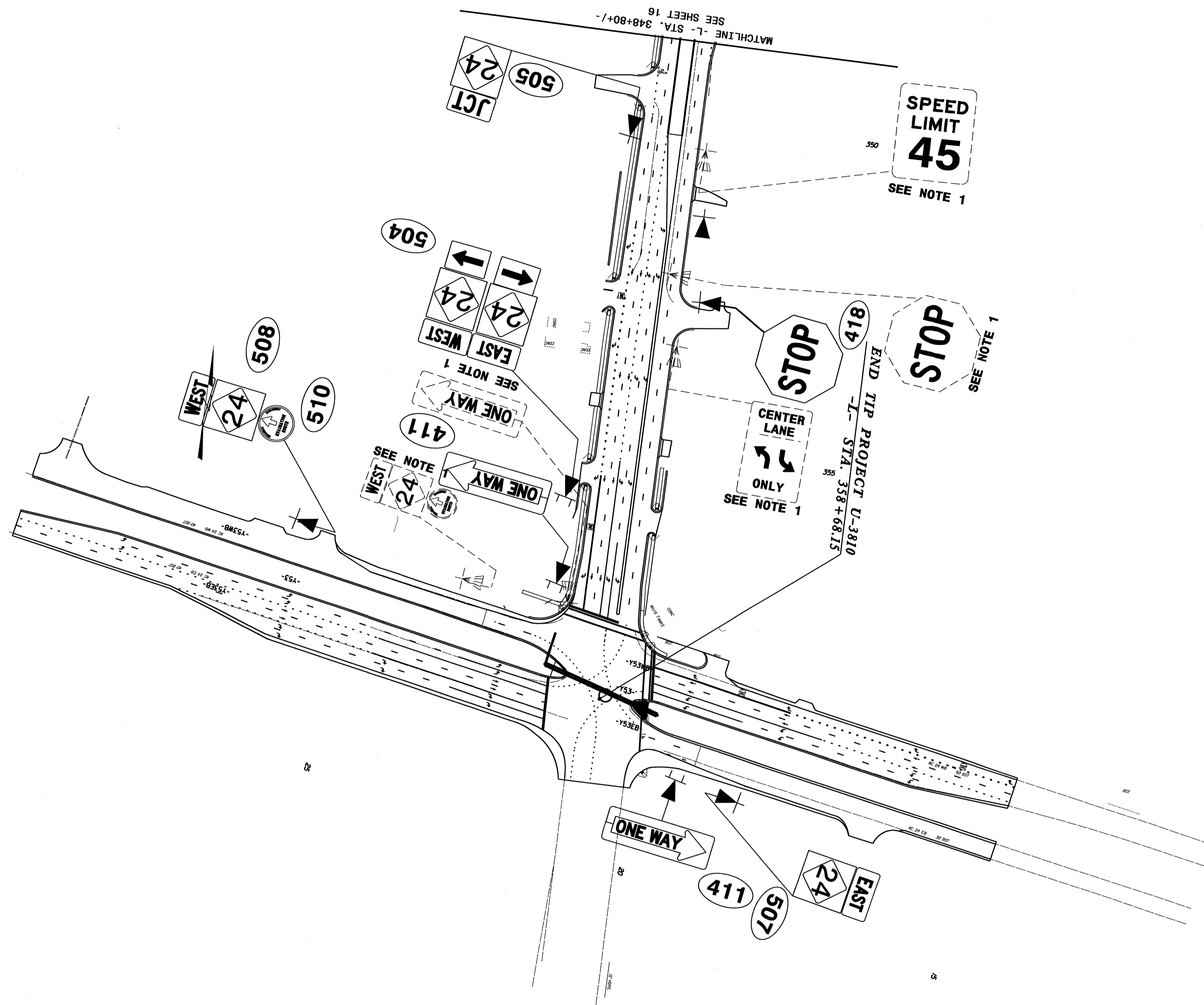

**EXISTING & PROPOSED SIGNS**  
**-L- STA. 348+80+/- TO 358+68.15**

07 JUN 2012 15:34  
 C:\CADD\Signing Layout Plans\U-3810.Sgn\_SGN.17\_existing.dgn  
 brown